

# Ferrolli

## PRODUCT RANGE 2012

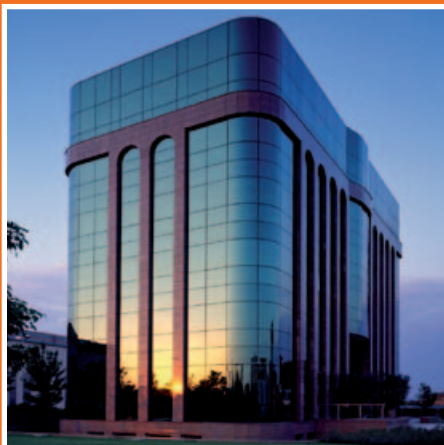

>>> INDUSTRIAL  
AIR-CONDITIONING <<<





FERROLI PRODUCT RANGE			44
MAIN CHARACTERISTICS WATER CHILLERS			50
AIR COOLED WATER CHILLERS			
With axial fans	RXA	R410A	58
	RMA	R410A	62
	RMA HE	R410A	66
	RGA	R410A	70
	RGA HE	R410A	74
	RTA	R410A	78
	RLA	R410A	82
	RLA HE	R410A	86
	RHA	R410A	90
	RHA HE	R410A	94
	RHV	R407C	98
	RHV	R134A	100
	RHV HE	R134A	104
With centrifugal fans	RMP	R410A	108
	RMP HE	R410A	112
	RGC	R410A	116
	RGC HE	R410A	120
WATER COOLED WATER CHILLERS	RGW	R410A	124
	RVW	R134A	128
DIRECT EXPANSION CONDENSING UNITS	CMA - CMA HE	R410A	132
	CMP - CMP HE	R410A	136
	CGA	R410A	140
	CGA HE	R410A	144
	CGC	R410A	148
	CGC HE	R410A	152
CONDENSERLESS UNITS	EGW	R410A	156
	EVW	R134A	160
MAIN CHARACTERISTICS TERMINAL UNITS			164
Fan coil unit	Fan coil TOP FAN plus		168
	Cassette FCS		172
Ceiling concealed	VHF3		178
Ducted fan coil	MERCURY SP		180
	TCD		182
	TCX		184
Large capacity fan coil	TCT		186
AIR HANDLING UNITS	FTP		188
PACKAGED ROOF TOP AIR CONDITIONER	RFA	R410A	190
HEAT RECOVERY UNITS	UT-REC		196
	UT-REC R		198
	UT-REC DP		200
	UT-REC DP F		202
EXHAUST AIR UNITS	EOLO 1		204

# > Ferroli production plant

THE PRODUCTION PLANT OF THE INDUSTRIAL AIR CONDITIONING DIVISION COVERS AN AREA OF 20,000 M<sup>2</sup> AND IS LOCATED IN VILLANOVA, NEAR SAN BONIFACIO (VR) CLOSE TO THE HEAD QUARTERS. RECENT IMPORTANT INVESTMENTS HAVE BEEN MADE TO IMPROVE AND UPGRADE THE PRODUCTION PROCESS STAGES.

A MICRO-FACTORY WITHIN THE MAIN PRODUCTION FACILITIES WITH **LEAN PRODUCTION** KANBAN SYSTEM PRODUCES HIGH SPECIFICATION FAN COIL TERMINALS.

## >>> INDUSTRIAL AIR-CONDITIONING <<<



>> The production process begins with the production of the finned coil in copper and aluminium, complete with a welding and testing line.



>> The assembly cell (picture opposite) assembles the components such as fan-motor, condensate tray and heat exchanger along with the main structure.



>> The final assembling and packaging cell assembles the cabinets and all components, such as valves, supplementary trays, and the controls.



>> Chillers with capacity from 5 to 350 kW are built on the assembly line. The 5 lines total a length of 300 m.





**Ferrolì**  
i migliori gradi centigradi

>> For the testing of medium to high capacity chillers (fig. a-b) there are three test chambers which enables units to be tested according to EUROVENT conditions. A very important investment by FERROLI, which offers our customers guarantee that our equipment fully comply the project specification.

>> The functional tests vary from a minimum of 4 hours for 20 kW units with heat pump (minimum 2 hours for operational mode) and up to 8 hours for 200 kW units (approx. 4 hours per operational mode). Complete test reports are compiled and made available to entire Ferrolì world.

>> Chillers up to 1400 kW (fig. c) are tested by specialised technical personnel who undergo a rigorous and intensive training schedules coordinated by the project engineers. Testing can last up to 8 hours for operation modes, with particular attention to ensuring correct operation of all alarms and adjustment functions of the units. Again complete test reports are compiled and made available to entire Ferrolì world.

>> Charts and reports for monitoring production schedules, efficiency, construction and the safety within the departments are updated and displayed (fig. d) inside the plant are available to all, as well as visiting customers and professionals.



# > Laboratory R&D

THE RESEARCH & DEVELOPMENT LABORATORIES ARE THE PRESTIGIOUS AREAS OF FERROLI PRODUCTION FACILITIES. INDIVIDUAL R & D LABORATORIES OPERATING INSIDE THE PRODUCTION PLANT ARE DEDICATED TO INDUSTRIAL AIR CONDITIONING TOTALLING AN AREA OF 1400 M<sup>2</sup>.

ITS MAIN DUTIES INCLUDE DESIGNING PROTOTYPES FOR THE TECHNICAL DEPARTMENT AND CARRYING OUT FUNCTIONAL TESTS IN D.B. AND W.B.

TEMPERATURE CONDITIONS CERTIFIED BY EUROVENT. THE RESEARCH AND DEVELOPMENT STRUCTURE COMPRISES A HEAD OF DEPARTMENT, FOUR TECHNICIANS FOR THE CONSTRUCTION OF PROTOTYPES AND ANOTHER FOUR LABORATORY TECHNICIANS FOR THE TESTINGS. THE NEW LABORATORY IS EQUIPPED WITH:

>> A compensated-type calorimeter **C2**, with a cavity separated chambers, for checking units up to  $P=16.5$  kW with the capability of testing units to a temperature of  $-10^{\circ}\text{C}$  (**fig. a**).

>> A calibrated-type calorimeter **C1** (with double chamber without cavity separated chambers where losses are taken into account) for checking units up to  $P=16.5$  kW and to a temperature of  $-10^{\circ}\text{C}$ , equipped inside with an enthalpy tunnel for calculating the performance of internal split or fan coil units up to  $Q=1,500$  m<sup>3</sup>/h, built to AMCA 210 specifications (**fig. a**).

>> A fan test tunnel, according to ISO 5801 and UNI 10531, for checking the air flow-rate values of axial-flow and tangential fans and monitoring of the flow-rate/head curve of centrifugal fans for values up to  $Q=5000$  m<sup>3</sup> (**fig. a**).

>> A semi anechoic chamber **C3** for sound power and pressure tests reconditioned for carrying out the tests at temperatures stipulated by Eurovent conditions. The chamber is suitable for units up to  $P=50$  kW and therefore for the whole range of terminal units and chillers up to the powers conditions;

>> All the chambers allow our technicians to control cooling only or heat pump units, with heat recovery in the de-superheating phase or total heat recovery and In addition process units for leaving water temperature down to  $-8^{\circ}\text{C}$ .



fig. a



fig. d



The Ferrol logo is positioned above the entrance of a large industrial chamber. It features the word "Ferrol" in a bold, black, sans-serif font, with a stylized orange arc above the letter 'o'.

Ferrol

The Ferrol logo is displayed prominently in the upper right corner of the page. It consists of the word "Ferrol" in a large, bold, black font, with a stylized orange arc above the letter 'o'. Below the main text, the tagline "i migliori gradi centigradi" is written in a smaller, black, sans-serif font.

Ferrol  
i migliori gradi centigradi

The financial investment in R&D in recent years have enabled the production of systems that meet individual market demands needs in terms of performance (efficiency, quiet operation, reliability).

>> The most significant and largest financial investment is certainly the climatic chamber C5, which is one of the largest in Italy and able to test units for powers up to 1800 kW (**fig. c-d**). The total internal volume (approx. 1200 m<sup>3</sup>) is controlled by a system of water and re circulated air circuits with inverter control and a smart software system enabling testing without personnel for temperatures to -10°C, with the option of dividing the chamber into separate zones for testing two units at the same time under different conditions.

>> The steam for test some unit is produced by a boiler at low pressure, specially designed by the industrial heating division technical department.

A photograph showing the interior of a large industrial climatic chamber. The chamber is brightly lit with overhead fluorescent lights. A person in a white lab coat is standing in the center, looking at a piece of equipment. The chamber has a large, open door on the left side, and various pipes and cables are visible inside.

fig. b

A photograph showing the exterior of the climatic chamber. The chamber is a large, white, rectangular structure with a blue door. A person in a white lab coat is standing in a control room area to the left of the door. The chamber is situated in a large industrial building with a high ceiling and exposed pipes.

fig. c



# > Ferroli's Italy references

## HOSPITAL AUTHORITIES

### **Milazzo (ME)**

RHA + RGA + AIR HANDLING UNIT

### **Piemonte (ME)**

RLA + FAN COIL

### **Roma S. Filippo Neri**

RMA + FAN COIL

### **Militare Celio (RM)**

AIR HANDLING UNIT + FAN COIL

### **Opera Pia (VB)**

RMA + FAN COIL

### **Cotugno (NA)**

RGA + AIR HANDLING UNIT + FAN COIL

### **Vecchio Palmanova (UD)**

FAN COIL

### **V. Emanuele Gela (RG)**

RHA + AIR HANDLING UNIT

### **Borgosesia (VC)**

RHV + AIR HANDLING UNIT

### **Misericordia (GR)**

FAN COIL

### **Silvestrini (PG)**

FAN COIL

### **Villa San Pietro (RM)**

AIR HANDLING UNIT

### **San Bonifacio (VR)**

AIR HANDLING UNIT

### **C. Poma (MN)**

FAN COIL

### **Monaldi (NA)**

RLA + AIR HANDLING UNIT

### **Sarcone (BA)**

RGA

### **S. Anna (CO)**

AIR HANDLING UNIT

### **Belcolle (VT)**

AIR HANDLING UNIT

### **Maggiore (BO)**

AIR HANDLING UNIT

### **S.Martino (GE)**

RGA

### **Barcellona (ME)**

AIR HANDLING UNIT

### **G. Rummo (BN)**

RGA

### **Cà Foncello (TV)**

AIR HANDLING UNIT

### **S. Maria della Circe (SI)**

AIR HANDLING UNIT

### **Vittorio Emanuele III (CL)**

AIR HANDLING UNIT

### **Vincenzo dell'Erba (BA)**

RMA + AIR HANDLING UNIT

### **Santhià (TO)**

RLA + FCF

### **Borgomanero**

RHA + AIR HANDLING UNIT

### **Roma Bambin Gesù**

AIR HANDLING UNIT + FANCOIL

### **Sandro Pertini (RM)**

RGA + FAN COIL

### **Manduria (TA)**

RXA + RMA + FAN COIL + DUCTED FAN COIL

### **Moscato (TA)**

RXA + DUCTED FAN COIL

### **S. Vito al Tagliamento (UD)**

AIR HANDLING UNIT + DUCTED FAN COIL

### **Niguarda (MI)**

DUCTED FAN COIL

### **Maggiore della Carità (NO)**

AIR HANDLING UNIT + RLA + RGA

### **Gubbio (PG)**

RGA + FAN COIL

### **Presidio Ospedaliero ASL n. 4 APICELLA (NA)**

RGA

### **Azienda Ospedaliera Senese (SI)**

RXA

### **Policlinico di Monza (MI)**

RGA

### **USL 4 di Prato (PO)**

AIR HANDLING UNIT + RGA + FAN COIL

### **USL 13 (BA)**

AIR HANDLING UNIT

### **ASL NAPOLI 2 (NA)**

AIR HANDLING UNIT

### **ASL di Frosinone (FR)**

RLA + AIR HANDLING UNIT

### **Casa di Cura Columbus (MI)**

AIR HANDLING UNIT

### **Istituto Zooprofilattico (SS)**

RLA + RHA

### **Regione Lazio (RM)**

AIR HANDLING UNIT

### **Clinica Villa Sandra (RM)**

AIR HANDLING UNIT

### **Casa di Cura S. Lorenzino (FC)**

RGA

### **Laboratorio TUV Scarmagno (TO)**

RGA + FCS

### **I.P.A.B. Ist. Giovanni XXIII (BO)**

RHA + AIR HANDLING UNIT

### **Centro Sterilizzazione "Steril Piemonte" (VC)**

RHV + RLA + AIR HANDLING UNIT

### **Ingegneria Biomedica S. Lucia (NO)**

RGA + FAN COIL

>>> INDUSTRIAL  
AIR-CONDITIONING <<<



San Bonifacio hospital (VR)

# > Ferroli's Italy references

SCHOOLS, UNIVERSITIES, LIBRARIES  
HOTELS  
CATERING

> SCHOOLS,  
UNIVERSITIES,  
LIBRARIES

**Liceo Classico  
S.M. Legnani (VA)**  
RGA + AIR HANDLING UNIT

**Biblioteca di Palazzo Chigi  
(RM)**  
FAN COIL

**Biblioteca Com. Macomer  
(SS)**  
ROOF TOP RFA

**Biblioteca Com. Caserta  
(CE)**  
RLA

**Università Magna Grecia  
(CZ)**  
AIR HANDLING UNIT

**IPSIA di Gallarate (VA)**  
AIR HANDLING UNIT

**Università di Bari (BA)**  
RGA + AIR HANDLING UNIT

**Università di Salerno (SA)**  
ROOF TOP RFA

**Palazzo Reale (NA)**  
RGC

**Politecnico di Bari**  
AIR HANDLING UNIT

**Campus Universitario (PI)**  
AIR HANDLING UNIT + FAN COIL

> HOTEL

**Hotel San Marco (VR)**  
AIR HANDLING UNIT

**Hotel Mediterraneo (RG)**  
RLA

**Hotel Baco da Seta (AQ)**  
RGA

**Hotel Torricella (PG)**  
RGA

**Hotel Tilibas (SS)**  
AIR HANDLING UNIT

**Hotel Tiberio Palace (NA)**  
AIR HANDLING UNIT

**Hotel Incanto (PI)**  
RGA

**Hotel Hilton (MT)**  
UT REC + TCX

**Residence "La Giurlita" (LE)**  
RMA + FCF + TCX

> CATERING

**Ristorante "Mare Rosso" (MI)**  
HSW

**Cantine le Cionce (GR)**  
RLA

**Cantina Zaccagnini (PE)**  
ROOF TOP

**Castello di Radda (SI)**  
AIR HANDLING UNIT

**Ristorante Santo Spirito (SA)**  
RLA + AIR HANDLING UNIT

**Villaggio turistico Casalvelino  
(SA)**  
RLA + FAN COIL

**Best Western Soave Hotel  
(VR)**  
RLA + FAN COIL + UT REC



>>> INDUSTRIAL  
AIR-CONDITIONING <<<



tiberio palace, hotel & conference center\_NAPOLI



tiberio palace, hotel & conference center\_NAPOLI

# > Ferroli's Italy references

BANKS  
OFFICES  
SALES OUTLETS

## > BANKS

**Monte dei Paschi di Siena**  
AIR HANDLING UNIT + DUCTED FAN COIL

**CMP - Poste Italiane (PG)**  
RLA + RGA + RMA

**Poste Italiane CMP (AN)**  
UT REC

**Poste Italiane (RM)**  
AIR HANDLING UNIT

**Banca Finconsumo**  
RSA + RPC + FAN COIL

**Banca d'Italia (BS)**  
RXA

## > OFFICES

**Regione Puglia (LE)**  
RGA

**Telecom S.P.A. (AQ)**  
FAN COIL

**Telecom S.p.A. (RM)**  
FAN COIL

**Pirelli R.E. (TO)**  
RVW

**Olivetti Multiservices SpA (TO)**  
AIR HANDLING UNIT

**Sede Municipale S. Teresa di Riva (ME)**  
RGA

**Direzione compartimentale Ferrovie Italiane (AN)**  
FCF + FCS

**Fiat Group - Ingest Facility (TO)**  
RGA + RLA + AIR HANDLING UNIT

**Autostrade italiane Direzione tronco 2 (MI)**  
AIR HANDLING UNIT

## > SALES OUTLETS

**Luisa Spagnoli S.P.A. (PG)**  
POLAR

**LIDL Cairo Montenotte (SV)**  
RGA

**Carrefour (NO)**  
RLA

**Brico Center (PV)**  
ROOF TOP

**Carrefour (CE)**  
TCX + FAN COIL

**Concessionaria AUDI (VC)**  
RGA

**Concessionaria AUDI (NO)**  
RLA

**Calisese Centrum (CE)**  
RLA + AIR HANDLING UNIT + DUCTED FAN COIL + VEC



>>> INDUSTRIAL  
AIR-CONDITIONING <<<



teatro san carlo NAPOLI

# > Ferroli's Italy references

MILITARY SECTOR  
LARGE AREAS

## > MILITARY SECTOR

**Caserma Guardia di Finanza “Cefalonia Corfù” (PG)**

FCF

**Scuola di Polizia Ministero Infrastrutture (RM)**

RFA + RMA + RGA + RLA

**Esercito Italiano (RM)**

CARRELLABILI

**Comando Guardia di Finanza (TP)**

RLA

**Caserma U. Polonio (GO)**

RGA + FAN COIL + AIR HANDLING UNIT

**Caserma Guardia di Finanza (RA)**

RGA + FCS

**Arsenale di Taranto (TA)**

RHA + FAN COIL + AIR HANDLING UNIT

**Scuola Militare di Cavalleria (TO)**

AIR HANDLING UNIT

**Caserma Carabinieri S. Bonifacio (VR)**

RGA + RMA

## > LARGE AREAS

**Centro Congressi (AR)**

AIR HANDLING UNIT + RLA + RGA

**Museo delle Scienze Naturali (BN)**

RGA + FAN COIL

**Piscina Intercomunale Fucecchio (FI)**

AIR HANDLING UNIT

**Museo Etnografico Caravel (AO)**

RGA + AIR HANDLING UNIT

**Museo Comunale (RN)**

RLA + AIR HANDLING UNIT

**Centro Comm.le Ortuso (RC)**

AIR HANDLING UNIT

**Centro Comm.le Corolla (ME)**

AIR HANDLING UNIT

**De Martini Shipping (GE)**

AIR HANDLING UNIT

**Teatro San Carlo (NA)**

AIR HANDLING UNIT

**Teatro Diana (SA)**

RLA

**Mercato Tartini (BO)**

AIR HANDLING UNIT

**Multisala Impero (VA)**

ROOF TOP

**Sala Bingo di Gallipoli (LE)**

ROOF TOP RFA

**Palazzo INAIL (VC)**

RGA

**EUROMA (RM)**

RHV

**Auditorium di Mantova (MN)**

RGA + AIR HANDLING UNIT

**Conservatorio Musicale (SA)**

RMA + FCS

**Centro Natatorio (MN)**

RLA + AIR HANDLING UNIT

**CUS Campo Hockey (PI)**

AIR HANDLING UNIT

**Palacilento (SA)**

RHA + AIR HANDLING UNIT



>>> INDUSTRIAL  
AIR-CONDITIONING <<<



# > Ferroli's Italy references

INDUSTRIES  
AIRPORTS

## > INDUSTRIES

**Stabilimento Versace S.P.A. (NO)**

RHA

**Stab. Artema S.P.A. Zegna (BI)**

RGA

**Stabilimento AIA (VR)**

RHA

**Gruppo Fendi S.P.A. (MI)**

AIR HANDLING UNIT

**Stab. Doimo City Line (TV)**

RLA

**Stabilimento LIOLÀ Spa (NO)**

RGA

**Stab. TYCO VALVES (PC)**

RGA

**Riseria Stroppiana (VC)**

RLA

**Finmeccanica (RM)**

RGA+

**Stabilimento Ferrero (CN)**

AIR HANDLING UNIT + RLA

**Concerie Settebello (PI)**

RHA + RGA

**Stabilimento Unoaerre (AR)**

RHV + AIR HANDLING UNIT

**Stabilimento Ericsson (NA)**

AIR HANDLING UNIT + FAN COIL

**Stabilimento Ansaldo (TO)**

RGA + AIR HANDLING UNIT + FAN COIL

**Cantiere S. Paolo (BA)**

RGA + FAN COIL + UT REC

**Stab. Missano S.p.A. (SA)**

RLA + RGA + AIR HANDLING UNIT

## > AIRPORTS

**Militare Base Nato (BR)**

RLA

**Fiumicino L. da Vinci (RM)**

AIR HANDLING UNIT

**Militare "F. Baracca" (RM)**

RGA

**Militare Pratica di Mare (RM)**

RLA + AIR HANDLING UNIT + FAN COIL



>>> INDUSTRIAL  
AIR-CONDITIONING <<<



Stabilimento Missano S.p.A. SALERNO



sede Finmeccanica ROMA

# > **Ferrol's Great Britain references**

GREAT BRITAIN

> GREAT BRITAIN

## ***Cherry Pipes***

***Plastic pipe company process application - Ireland***

[RHA](#)

## ***London Gallery***

***Art gallery commercial cooling application - London***

[RHV](#)

## ***Spectrum Centre***

***Shankhill Road office cooling - Belfast Ireland***

[RGA](#)

## ***Sussex Farm process cooling - England***

[RHV](#)



>>> INDUSTRIAL  
AIR-CONDITIONING <<<<



London Gallery - London



Cherry Pipes - Ireland



# > **Ferrolì's Great Britain references**

GREAT BRITAIN

> GREAT BRITAIN

***Royal Theatre - London***

RGÀ

***Harrogate International Conference Centre - London***

RLA

***Crowne Plaza Hotel - Colchester - England***

RLA + TOP FAN



>>> INDUSTRIAL  
AIR-CONDITIONING <<<



Theatre Royal - London



Crowne Plaza Hotel - Colchester - England



Royal Theatre - London

# > Ferrolí's Spain references

SPAIN - ESPAÑA

> SPAIN

*Hospital de Alta Resolución de Loja*

*Hospital de Sagrado Corazón*

*Hospital Meixorio de Vigo*

*Hospital de Enfermedades Raras*

*Hospital Benito Menni*

*Hospital Xanit*

*Centro Salud Manzanares*

*Clinica Cefer*

*Rehabilitación oficinas*

*Mercado Municipal*

*Museo de Calahorra*

*Colegio Corazonistas*

*Edificio Presidencia de la  
Generalitat*

*Edificio banco España*

*Polideportivo Parque Coimbra*

*Polideportivo Siec*

*Facultad de Derecho*

*Centro Cultural Bembrive*

*Edificio Banco Espana*

*Ayuntamiento*

*Complejo Hotelero Terralta*

*Hotel Carlton*

*Hotel Fuente Las Piedras*

*Hotel San francisco*

*Hotel El Espinar*

*Hotel Acosta*

*Hotel Parador*

*Hotel Villa de Benavente*

*Hotel Meridional*

*Hotel Benidorm*

*Hotel Balneario de Orio*

*Hotel Abando*

*Juzgados de Olot*



>>> INDUSTRIAL  
AIR-CONDITIONING <<<<



Complejo HOTELERO TERRALTA Alicante (Spagna)



Los Pilares del Estado Gijón (Spagna)



Hotels CARLTON Bilbao (Spagna)

# > Ferroli's Romania references

ROMANIA - ROMÂNIA

> ROMANIA

**RSI Electro Office Building - Bucuresti**

RGA

**Office Building Vitan - Bucuresti**

RLA

**Office Building Pipera**

**Hotel Floreasca - Bucuresti**

RGA

**Hotel Rodna - Bistrita**

RGA

**Hotel Maxim - Oradea**

RGA

**Ness Service - Dvd Factory**

**Sediu Galmopan - Galati**

RGA

**Sediu Arabesque - Brasov**

RGA

**Moticica Grup - Timisoara**

RGA

**MMM Automotive - Turda**

RGA

**Climatherm Center - Iasi**

RGA

**Frigoglass Romania - Timisoara**

RLA

**Teo Center - Brasov**

RLA

**Amma Print - Bucuresti**

AIR HANDLING UNIT + RHA

**RH Printing - Bucuresti**

RHA

**Reamedia - Bucuresti**

RHV

**Delphi Romania - Ineu**

AIR HANDLING UNIT

**Club Office - Sighisoara**

AIR HANDLING UNIT

**Cazino - Sighisoara**

AIR HANDLING UNIT

**Aeroport - Sibiu**

AIR HANDLING UNIT + RHA

**ODS Business Service - DVD – Bucuresti**

AIR HANDLING UNIT

**Manoil Mall - Galati**

AIR HANDLING UNIT

**Bazin Olimpic - Resita**

AIR HANDLING UNIT

**Sala Sporturilor - Onesti**

AIR HANDLING UNIT

**Stabilus - Brasov**

RLA

**Stella Building / Jules Verne - Bucuresti**

RLA

**Sempo S A - Bucuresti**

RLA

**Loial - Sibiu**

AIR HANDLING UNIT

**MAGAZINE DEDEMAN 2010**

**Craiova** RFA

**Brasov** RFA

**Arad** RFA

**Timisoara** RFA

**Resita** RFA

**Cluj Napoca** RFA

**Sediu birouri Dedeman- Bacau**

VN + AIR HANDLING UNITS + RHV + TCX

**MALL Cetatea Noua- Oradea**

MERCURY SP + AIR HANDLING UNITS + RHA + RHV + EOLO

**Consiliul Judetean - Sibiu**

VM-B + FCS

**Depozit EVW Gilau- Cluj**

RGA + VM-F

**MALL - Tr Severin**

RHV + AIR HANDLING UNITS



>>> INDUSTRIAL  
AIR-CONDITIONING <<<



# > Ferrolì's Romania references

ROMANIA - ROMÂNIA

> ROMANIA

## **Sediu GENPACT ROMANIA - Bucuresti**

RLA + AIR handling units

## **Clinica Regina Maria - Bucuresti**

RGA

## **Club Euphoria - Cluj**

RMA + AIR handling units

## **Banca Transilvania Baritiu - Cluj**

RGA + TOP FAN + FCS+ AIR handling unit

## **Banca Millenium - Cluj**

FCS

## **Banca Transilvania - Cluj**

FCS



>>> INDUSTRIAL  
AIR-CONDITIONING <<<<

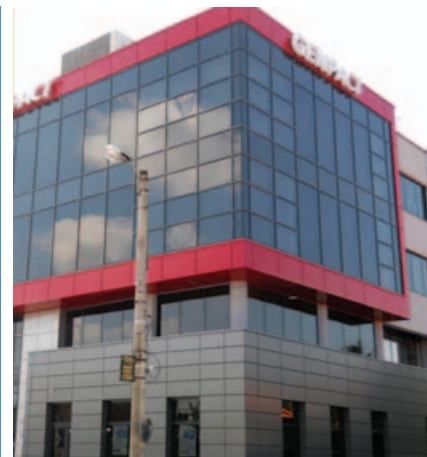

Banca Millenium - Cluj (Romania)



Clinica regina Maria - Bucuresti (Romania)



Banca Transilvania - Cluj (Romania)



Club Euphoria - Cluj (Romania)



Banca Transilvania Baritii - Cluj (Romania)

# > Ferrol's Czech Republic references

CZECH REPUBLIC

> CZECH REPUBLIC

## ***Hotel Celnice Břeclav***

RXA + TOP-FAN

## ***MERLIN PLUS Břeclav, stock of oil and offices***

TOP-FAN

## ***MORAVINO Valtice, winegrowing***

RXA

## ***NOVE VINARSTVI Drnholec, winegrowing***

RXA + TOP-FAN

## ***Vila Antonia, prestige offices Ostrava***

RGA

## ***Mikro Trading Podivin, logistic and stocking centre of toys***

RXA + TOP-FAN



>>> INDUSTRIAL  
AIR-CONDITIONING <<<<



Vila Antonia Ostrava



Hotel Celnice Břeclav



Merlin Plus Břeclav



Moravino Valtice



Nove Vinarstvi Drnholec

# > Ferrolì's Russia & Republic of Belarus references

РОССИЯ - RUSSIA

РЕСПУБЛИКА БЕЛАРУСЬ - THE REPUBLIC OF BELARUS

## > RUSSIA

**Commercial Center " ARMADA" - Moscow,**  
RHV + VHF3

**"KUBA" Commercial Center - Chelyabinsk,**  
RHV + FCS

**Centre of the positron-issue tomography - Chelyabinsk,**  
RGA + FCS + TOP FAN

**Commercial center" Moscow prospect" - Moscow,**  
RGA + TOP FAN VB-M + VHF3, RHV

**"SBERBANK" - Moscow,**  
RGA + CMA + TOP FAN

**Bank "URALSIB" - Moscow,**  
RGA

**Factory of Technical line production - Frazevo,**  
RGA

**JEWELLER Department store - Krasnodar,**  
RGA + TOP FAN

**"Kvaevitskiy Museum" - Krasnodar,**  
RGA + TOP FAN

**"Medical center branch" - Moscow,**  
RGA + FCP

**Business Hotel - Krassnodar,**  
RGA + RLA

**"Historical - Archeological Museum - Felizina"**  
FCS

**Trade Center Fresh Rostov na Donu**  
RLA + RGA

**Motor Show "KIA MOTORS" - Moscow,**

**"LUKOIL" the educational training center - Astrakhan,**

**Sandwiches-panel Factory - Shahty,**  
RGA

## > THE REPUBLIC OF BELARUS

**The Skating Ring "Ice Palace" - Baranovichì,**

**Republican theoretical and practical Center "Mother and Child" - Minsk,**

**9- th municipal clinical hospital - Minsk,**

**Research and Production Corporation "Integral" - Minsk,**

**Business Center "BME BUSINESS CENTER" - Minsk,**

**Republican theoretical and practical Center of oncology and medical radiology - Minsk,**

**BMW offices and service center - Minsk,**

**Business Center "Europe" - Minsk,**

**Unitary enterprise "Mucipal Bathhouses" - Minsk,**

**Belmicrosystems Reseach & Design Center - Minsk,**

**Organizations of the NASB Department of Chemical and Earth Sciences - Minsk,**



# >>> INDUSTRIAL AIR-CONDITIONING <<<<



**Armada Mall - Moscow**



**Felizina - RUSSIA**



**Trade Center Fresh - Rostov**

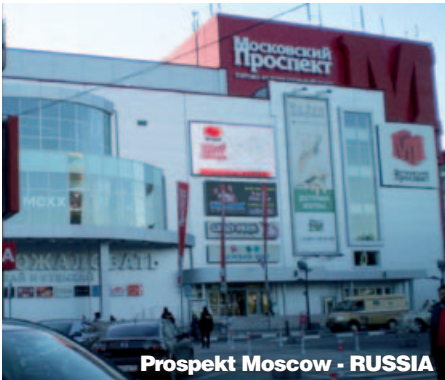

**Prospekt Moscow - RUSSIA**



**Motor Show "KIA Motors" - Moscow**



**"SBERBANK" - Moscow**



**Bank "URALSIB" - Moscow**



**"KUBA" Commercial Center - Chelyabinsk**



**Centre of the positron-issue tomography - Chelyabinsk**



**"LUKOIL" the educational training center - Astrakhan**



**Sandwiches-panel Factory - Shahty**



**Sandwiches-panel Factory - Shahty**

# > Ferroli's Turkey references

TURKEY - TÜRKÇE

> TURCHIA

**Turkmenistan Projeleri - Turkmenistan,**

RHV + RGA + RLA + RHA + FAN COIL + RFA

**Aksoy plaza - Izmir,**

RLA + TCX

**Ticaret Odasi - Kocaeli,**

RGA

**EAGLE Burgmann - Kocaeli,**

RXA + RMA

**BS Press - Izmit,**

RHV + TOP FAN

**Tekirdag Trade Center - Tekirdağ,**

FCS + TCX

**Tekirdag Accounting center - Tekirdağ,**

RMA + FCS

**Işviçre Hospital - Istanbul,**

RGA + TOP FAN

**Lady Diana Hotel - Istanbul,**

RHA + TOP FAN + UT REC DP F

**Aslan Hotel - Küthya**

RGA + AHU

**Panorama Otelcilik - Kayseri**

RHA

**Eyüpoğlu Hotel - Istanbul,**

RGA

**Lidersan - Gaziantep,**

RFA

**Cemdag Plastik - Izmir,**

RHA

**Plasko Plastik - Tekirda**

RLA + RGA + TCX

**Yildiz Plastik - Istanbul,**

RGA

**Cemdağ Aydınlatma Plastik - Izmir,**

RHA

**ÖzmeK Plastik - Istanbul,**

RGA

**Önder Plastik - Gebze**

RXA + RGA

**AUDI Showroom - Gaziantep,**

RGA + FAN COIL

**Mitsubishi Servis & Showroom - Istanbul,**

RGA

**Namlıoğlu Restaurant - Istanbul,**

RGA

**Sultançiftliği Aışveriş Merkezi - Istanbul,**

RGA + RHA

**Izmit Skoda Plaza - Kocaeli,**

RGA + FAN COIL

**Mitsubishi Servis & Showroom - Istanbul,**

RGA

**Van Hastanesi - Van,**

RGA

**Yasam Hastanesi**

RLA + TOP FAN + FCS

**Kazakistan AVM**

RHA + TOP FAN

**Dokuz Eylül Üniversitesi Hastane - Izmir,**

RGA

**Ege Üniversitesi Ziraat Fakül**

RMA

**Izmit Ticaret Odasi - Izmit,**

RHA

**Metal Dizayn Tesisleri - Istanbul,**

RLA

**Izmit Karşıyaka Kültür Merkezi - Kocaeli,**

RHA

**Uğur Teneke Tesisleri Aydınlat - Kocaeli,**

RHA + RLA + RMA



>>> INDUSTRIAL  
AIR-CONDITIONING <<<



Projeleri (Türkmenistan)



Projeleri (Türkmenistan)



Lady Diana Hotel



Plasko Plastik

# > Ferroli's Poland references

INDUSTRIES / PLANT

HOTELE - RESTAURACJE / HOTELS - CATERING

SCHOOLS / SZKOLY

SZPITAL CENTRUM MEDYCZNE MEDYCZNE / HOSPITAL AUTHORITIES

## > INDUSTRIES

**Budynki Biurowe BLACHOTRAPEZ  
Warszawa - Sękocin**

RMA

**Budynek biurowy ARCUS Gliwice**

CMA + FCP and TOP FAN

**Budynki Biurowe METALKOP Młyny k  
Buska Zdroju**

CMA + FCS

**Budynki Biurowe POLYNT - Niepołomice**

RMA + TOP FAN

**Budynki biurowe STACO - Niepołomice**

RMA + TOP FAN

**Budynek Biurowy ASSECO - Rzeszów**

RGA + FCP

**Linia technologiczna w Zakładach Produkcji  
Grzejników Stalowych BRUGMANN  
Legnicy**

RGA

**Budynek Biurowy PANTEON - Bytom**

CMA + FCP + UT-REC

**Budynki Biurowe GTM - Mysłowice**

RXA + TOP FAN + UT-REC

**Wylęgarnia Drobiu - Sierpc**

CMA

**Budynek Biurowy SOLAR-BIN - Rzeszów**

RGA + TOP FAN + TCX

**FIAT AUTO POLAND Bielsko - Biała**

RLA

**Drukarnia CGS - Poznań**

RGA + roof-top RFA + TOP FAN + FCS + UT-REC + FCS

## > HOTELE RESTAURACJE

**Hotel ADAM - Szczyrk**

FCS

**Restauracja z hotelem Karczma  
Górska” - Wałbrzych**

CMA + TOP FAN

**Dworek Kościuszko - Krakow**

RMA + TOP FAN

## > SZKOLY

**Sala Sportowa przy Szkole Podstawowej  
w Porębie k - Zawiercia**

rooftop RFA

**Państwowa Szkoła Wyższa  
Zawodowa w - Krośno**

CMA + FCS

**Magistrat Urzędu Miasta i Gminy  
Niepołomice**

RGA + RVL + TOP FAN + SOFFIO

## > SZPITAL CENTRUM MEDYCZNE

**Szpital Wojewódzki Bielsko - Biała**

RLA

**Wojewódzka Stacja Weterynaryjna w  
Legnicy**

RGA + TOP FAN

**Medical Center SILESIA-MED. - Katowice**

RGA + TOP FAN + FCS + UT-REC

**Medical Center MEDICOR - Wrocław**

RMA + FCP



>>> INDUSTRIAL  
AIR-CONDITIONING <<<



Drukarnia CGS Poznań



Biura (uffici/office) Inżynierska Łódź

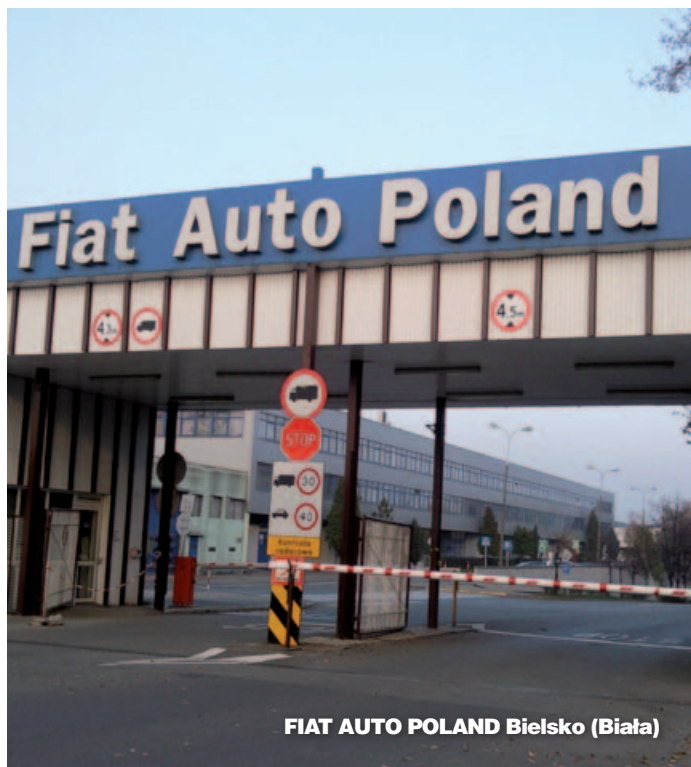

FIAT AUTO POLAND Bielsko (Biała)



Biura Arcus Gliwice

# > Ferroli's Balkan references

SRBIJA  
CROATIA  
BULGARIA  
BIH

## > SRBIJA

### **Dedinje 3 objekta - Beograd**

RXA + TOP FAN

### **Shopping center New Nork - Novi Sad**

RLA + FCS + UT REC DP

## > CROATIA

### **Mrksina - Zagreb**

RGA + RMA + TOP FAN

### **Bulvanova - Zagreb**

RMC + TOP FAN

### **Dugopolje - Split**

RGA + TOP FAN

### **AUTO CENTAR ŠKODA - Zagreb**

RGA + TOP FAN

### **AUTO CENTAR CITREN - Zagreb**

RGA + TOP FAN

### **MOTEL ZIR, Auto put A1**

RMA + TOP FAN

### **Zgrada Gradske Uprave Belišće**

RGA + TOP FAN

### **Upravna zgrada Miagro d.o.o. Našice**

RGA + TOP FAN

### **Vinkovci, regionalni prodajni centri - Bosso**

RGA + TOP FAN

## > BULGARIA

### **Kamchia resort**

RHA + RLA + TOP FAN

## > BIH

### **FC - franšizni centar - Vitez**

RGA + TOP FAN + FCS

### **FIS - Vitez**

RGA + TOP FAN

### **Pivovara Sarajevo - Sarajevo**

RGA

### **Hotel Central - Vitez**

TOP FAN + FCS

### **Hotel Tilija - Gračanica**

TOP FAN + FCS

### **Airport Dubrave - Tuzla**

WATER CHILLERS

### **Jafa-Jase factory - Špionica**

WATER CHILLERS + FAN COIL

### **Interex Shopping centers CDEB Sarajevo**

WATER CHILLERS + FAN COIL + MERCURY

### **International building Kendi - Tuzla**

TOP FAN

### **Trocal - Tuzla**

TOP FAN

### **Hotel SAX - Vlačić**

TOP FAN

### **MBI Development Malaysia Central Sarajevo**

WATER CHILLERS + FAN COIL

### **Edo Slad ETNA - Gračanica**

WATER CHILLERS + FAN COIL

### **BINGO d.o.o - Tuzla**

WATER CHILLERS + FAN COIL + MERCURY

### **BINGO d.o.o - Brčko**

WATER CHILLERS + FAN COIL + MERCURY

### **BINGO d.o.o - Gradačanica**

WATER CHILLERS + FAN COIL + MERCURY

### **OMEGA d.o.o. - Tuzla**

RLA + FAN COIL + MERCURY

### **Kopex Sarajlić - Sarajevo**

WATER CHILLERS + FAN COIL



>>> INDUSTRIAL  
AIR-CONDITIONING <<<<





# > Ferroli's Albania references

## > ALBANIA

### ***Drejtoria e policise - Tirane***

RHA + TOP FAN

### ***TEC - VLORE***

RGA + FTP + TOP FAN

### ***Center shqipetare***

RLA + TOP FAN + TCX

### ***Dieoqeza e rrethit mirdite***

RGA + TOP FAN

### ***American hospital - Tirana***

RGA + TOP FAN + TCX + FTP

### ***Drejtoria e policise - Durres***

RGA + TOP FAN

### ***Karburant - Alpet***

RGA + TOP FAN

### ***Bkt (banka kombetare tregetare) - Korçe***

TOP FAN

### ***Hotel Tomorri - Berat***

RGA + TOP FAN

### ***Reparti Ushtarak - Zallherr***

>>> INDUSTRIAL  
AIR-CONDITIONING <<<



DREJTORIA E POLICISE



TEC - VLORE



Center Shqiptare

# > Ferrol's Syria references

> SYRIA

**Ghandour Factory - Damascus**

RHV

**Matouk's office - Damascus**

RGA ST + TOP FAN

**Semiramis Hotel - Palmira**

AHU + TOP FAN

**Massa Plaza (Malki Mall) - Damascus**

FCS

**Kalde Factory - Damascus**

RLA



>>> INDUSTRIAL  
AIR-CONDITIONING <<<



Kalde Factory - Damascus



Ghandour Factory - Damascus



Matouk's Office - Damascus.



Semiramis Hotel - Palmira

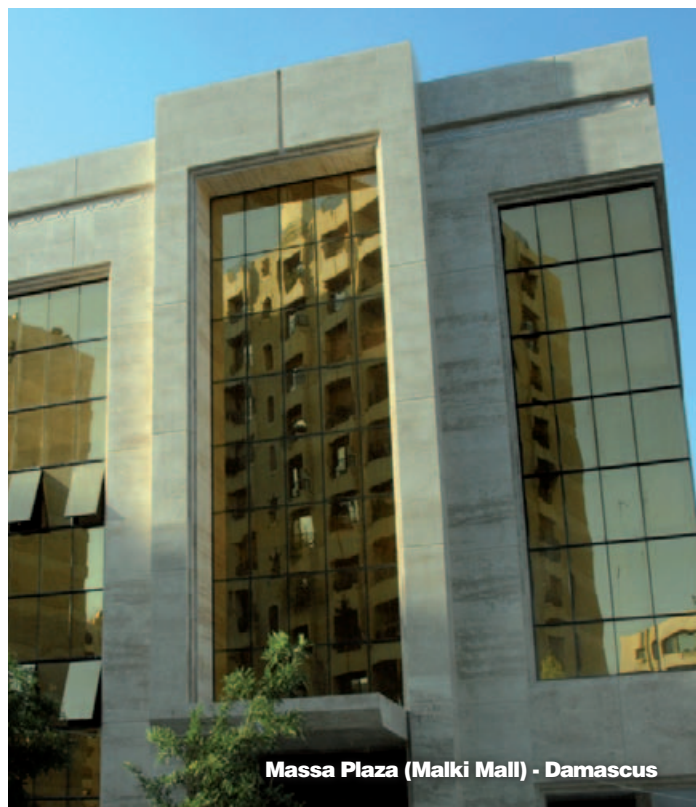

Massa Plaza (Malki Mall) - Damascus

# > Ferrol's Syria references

## > SYRIA

### ***Alkalamoon University Hospital - Deir Atiah***

RLA + AIR Handling Units

### ***Julia Dumna Palace - Aleppo***

RGA + TOP FAN

### ***Gandar Power Plant - Gandar***

RGA + TOP FAN

### ***Nestle Factory - Damascus***

TOP FAN

### ***Iraq Ambassador Resident - Damascus***

RGA + TOP FAN

### ***Almandine Hospital - Damascus***

TOP FAN

### ***Dr. Maatouk Villa Yaafour- Damascus***

RGA + TOP FAN

### ***Residential Projects- Damascus***

TOP FAN



>>> INDUSTRIAL  
AIR-CONDITIONING <<<<





# Ferroli product range

## AIR COOLED WATER CHILLER WITH AXIAL FANS

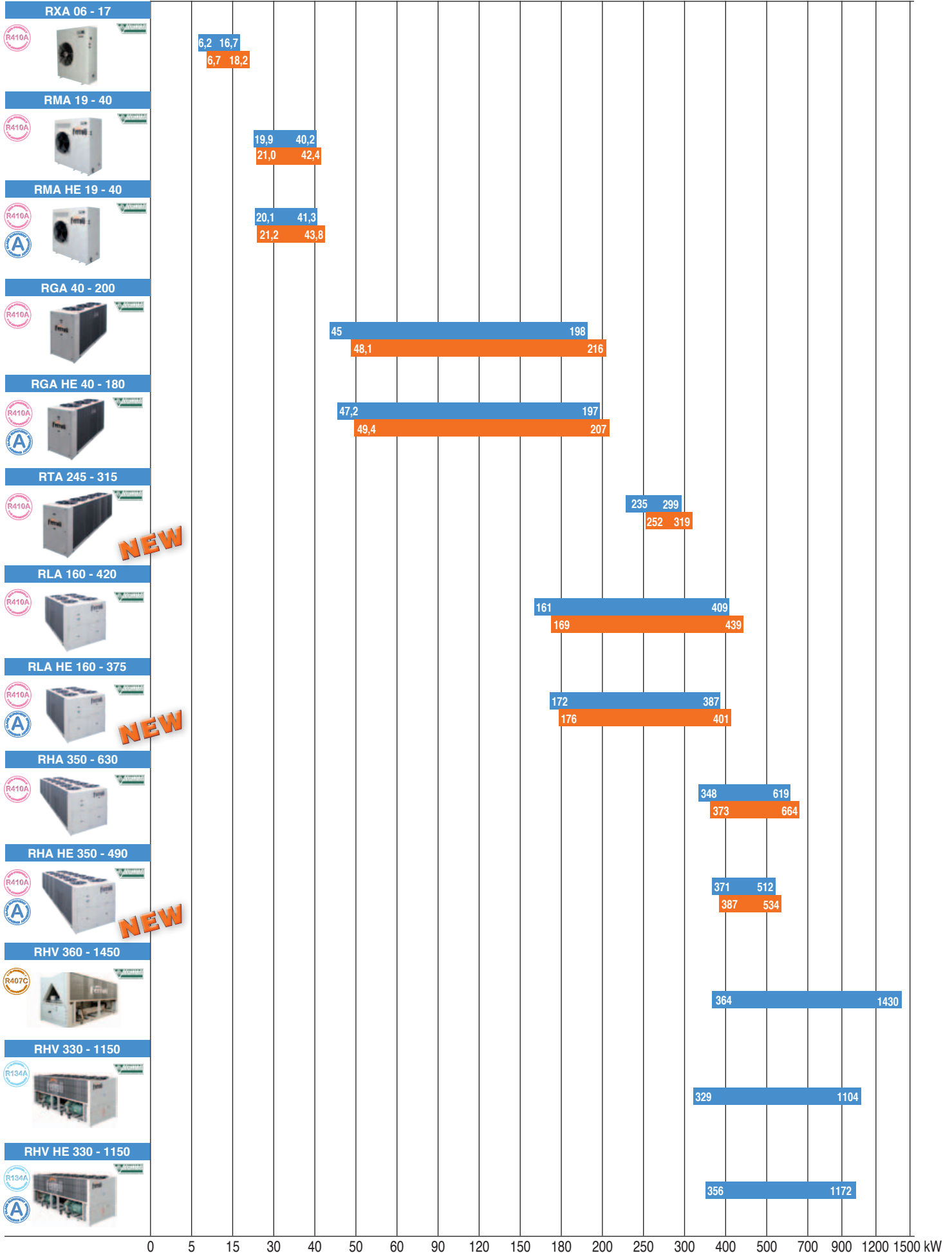

# Ferroli product range

## AIR COOLED WATER CHILLER WITH CENTRIFUGAL FANS

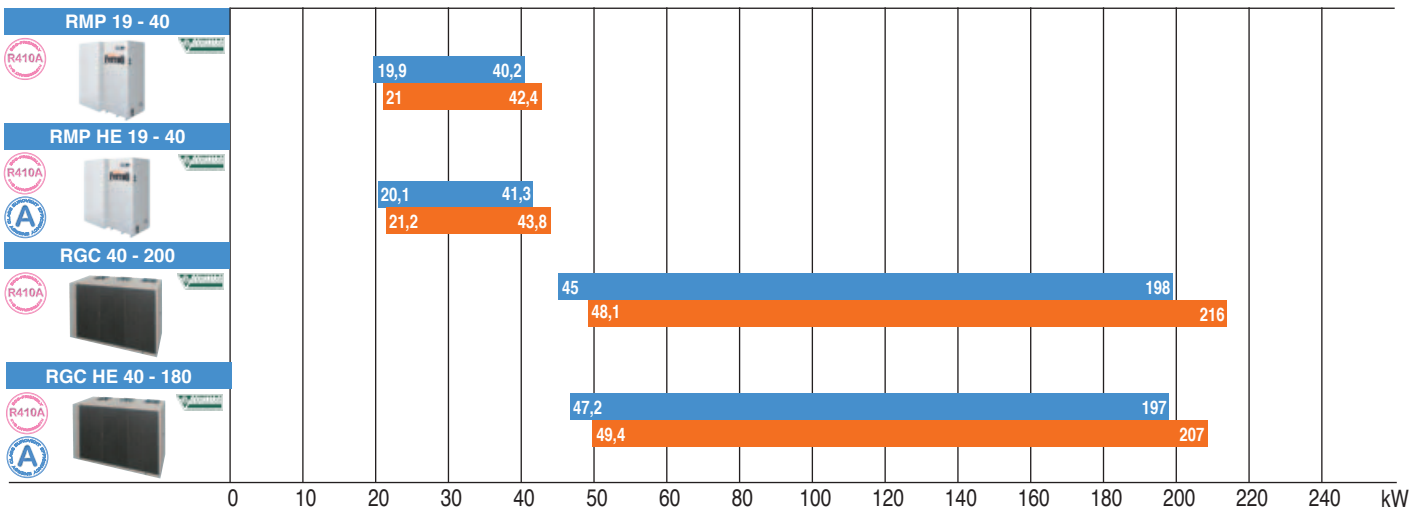

## WATER COOLED WATER CHILLERS

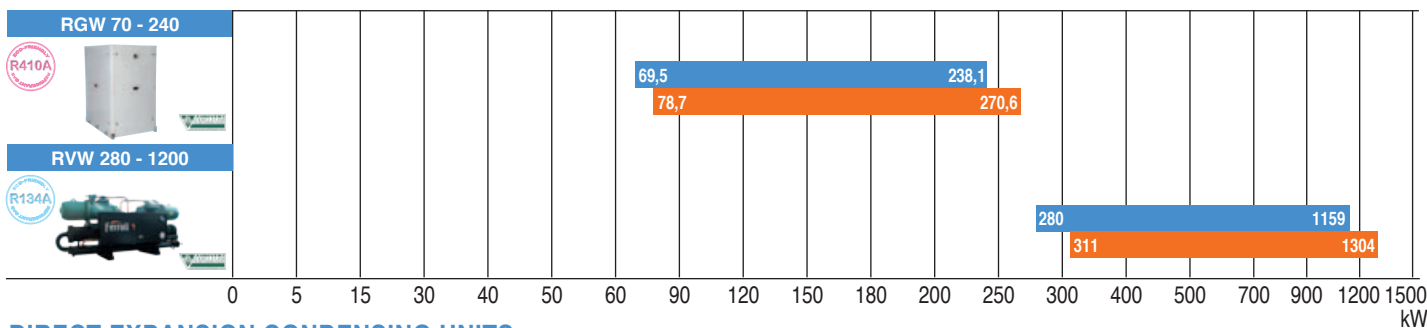

## DIRECT EXPANSION CONDENSING UNITS

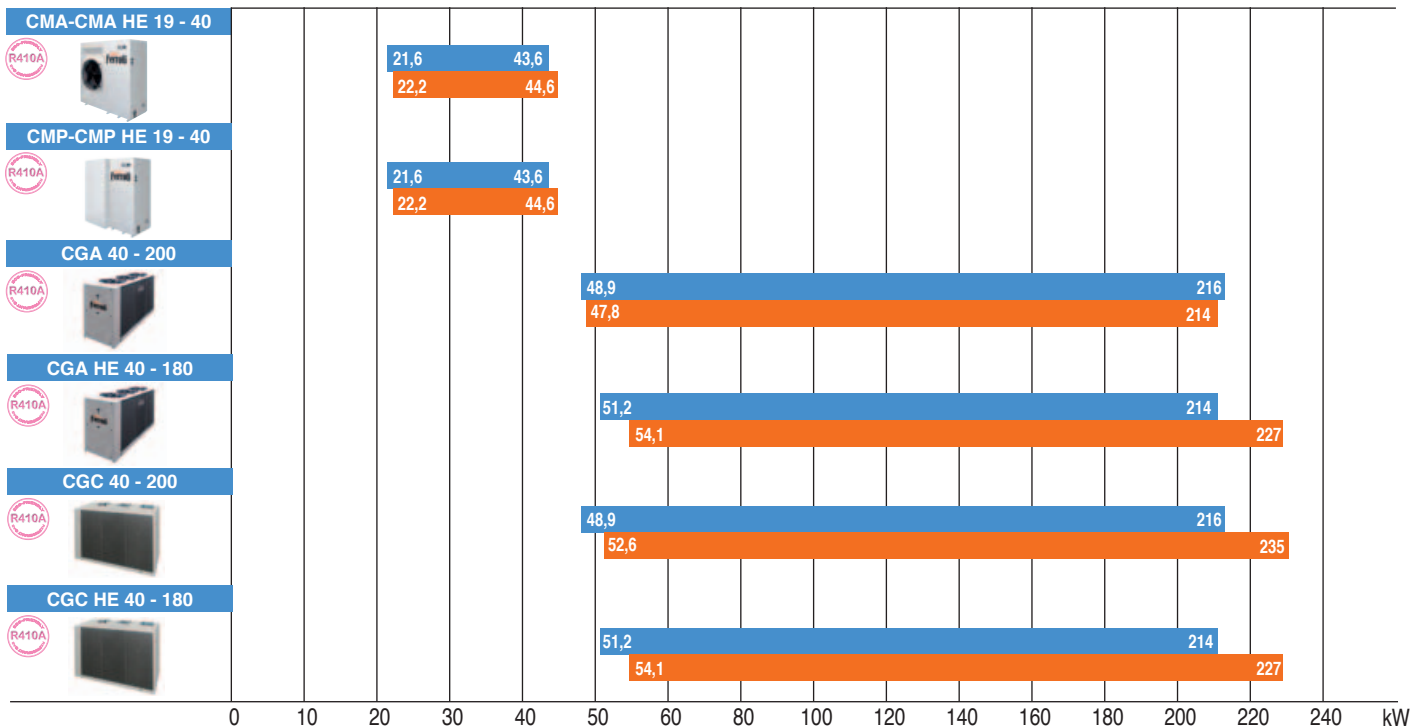

## REMOTE AIR COOLED CHILLERS

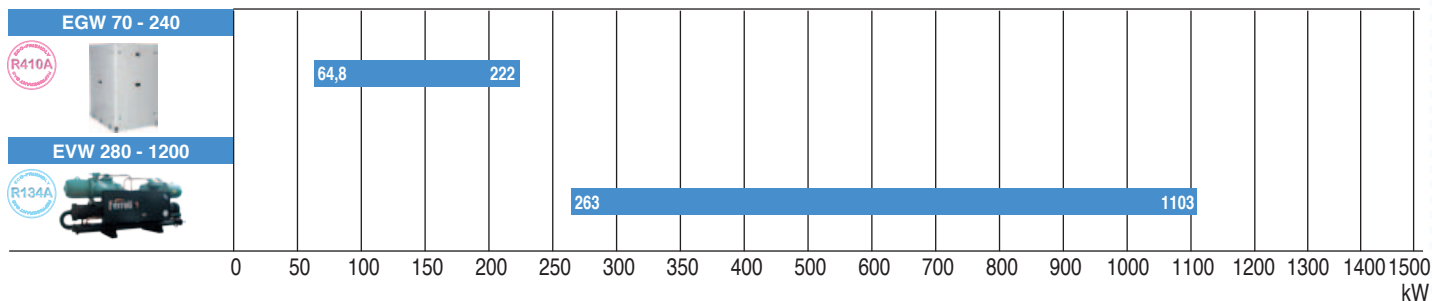

# Ferroli product range

## FAN COIL UNIT

TOP FAN PLUS 15 - 120



FCS 04 - 20

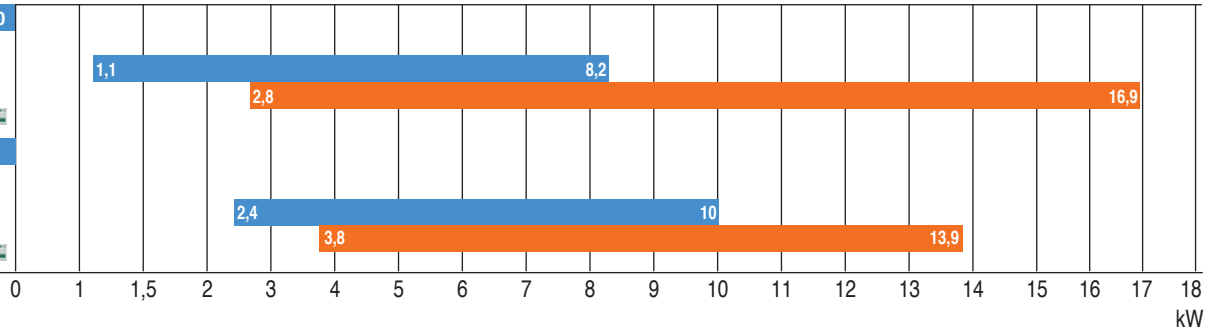
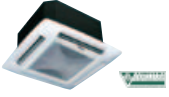

## CEILING CONCEALED

FCF PLUS VN and VN-3V

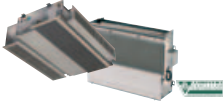

VHF3 50 - 28

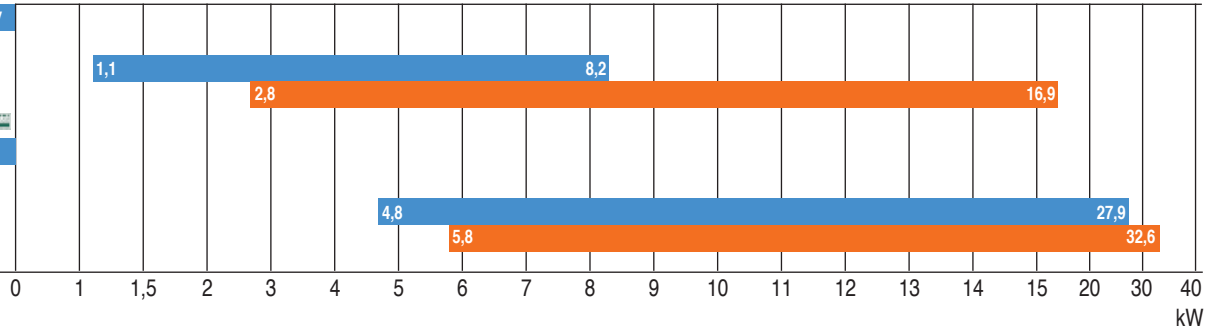

## DUCTED FAN COIL

MERCURY SP 05 - 23



TCD 11 - 41



TCX 10 - 60

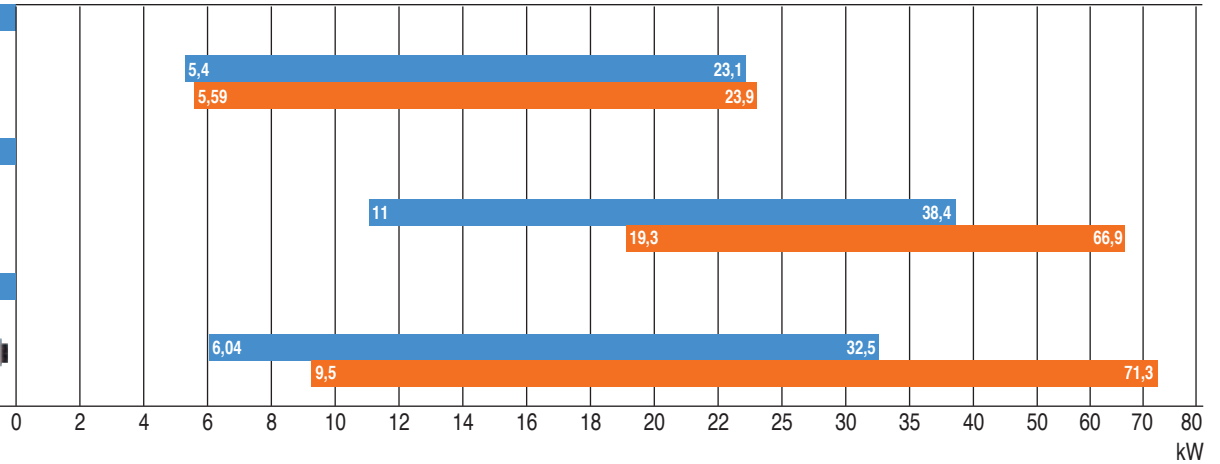



# Ferroli product range

## LARGE CAPACITY FAN COIL

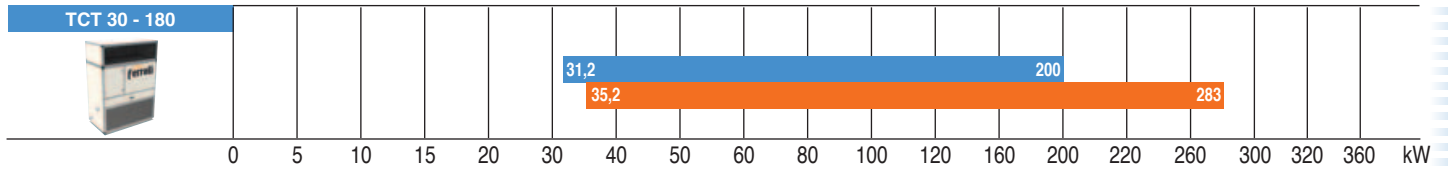

## AIR HANDLING UNITS

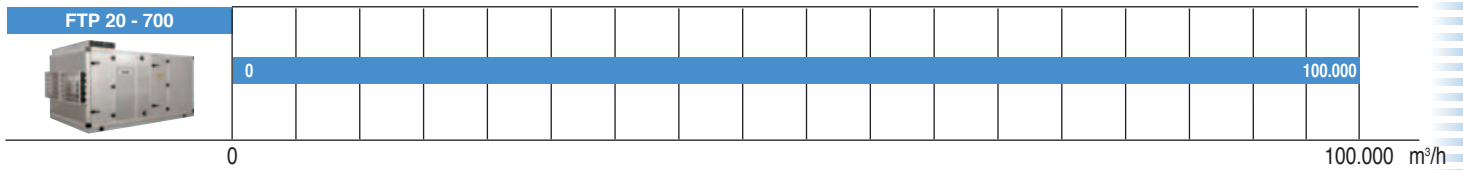

## PACKAGED ROOF TOP AIR CONDITIONER

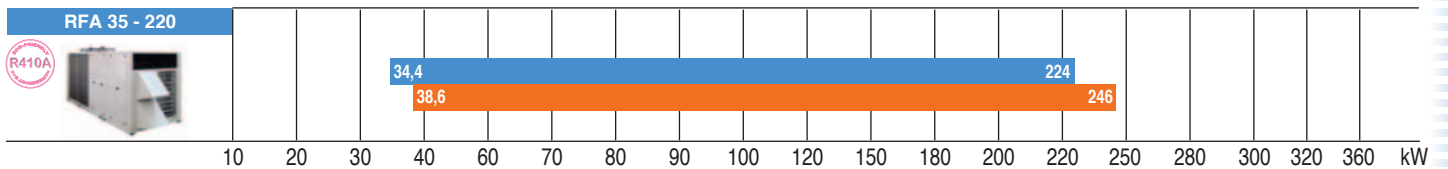

## HEAT RECOVERY UNITS

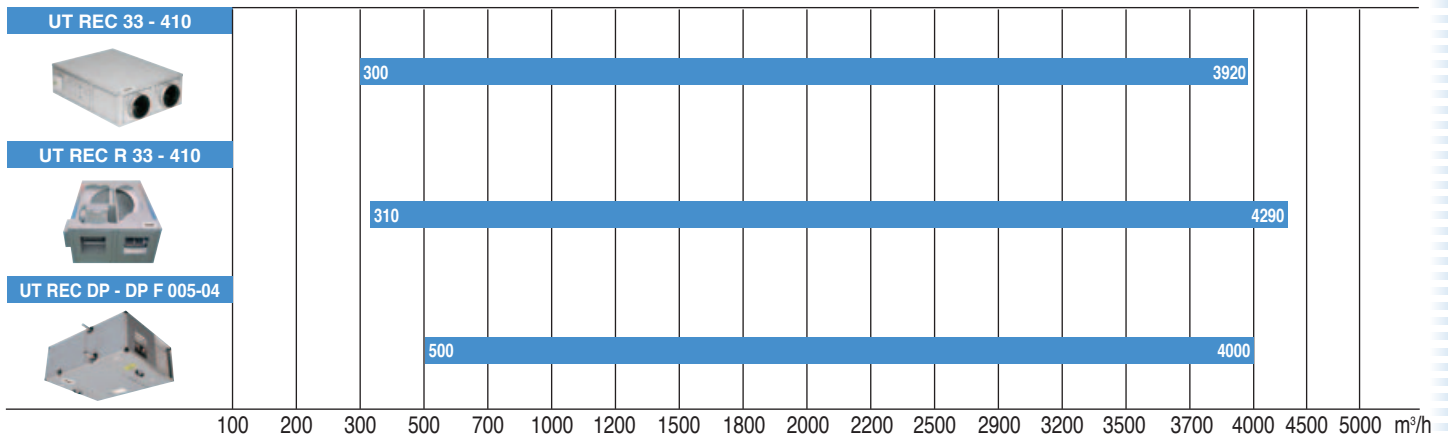

## EXHAUST AIR UNITS

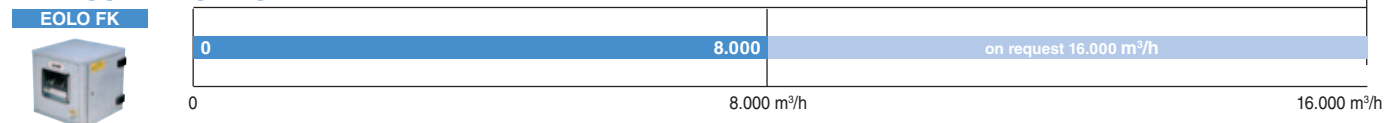

# > News 2012

## CHILLERS

### > RTA

AIR-WATER CHILLERS AND HEAT PUMPS FOR OUTDOOR INSTALLATION

#### Unit type

- IR Chiller
- IP Heat pump  
(reversible on the refrigerant side)
- BR Chiller Brine
- BP Heat pump Brine  
(reversible on the refrigerant side)

#### Version

- VB Base version
- VD Desuperheater version
- VR Total recovery version

#### Acoustic setting up

- AB Base setting up
- AS Low noise setting up
- AX eXtra low noise setting up

#### Source temperature level

- M Medium temperature level
- A High temperature level



3 COMPRESSORS  
1 CIRCUIT

### > RLA HE

AIR-WATER CHILLERS AND HEAT PUMPS FOR OUTDOOR INSTALLATION

#### Unit type

- IR Chiller
- IP Heat pump  
(reversible on the refrigerant side)
- BR Chiller Brine
- BP Heat pump Brine  
(reversible on the refrigerant side)

#### Versions

- VB Base Version
- VD Desuperheater version
- VR Total Heat Recovery Version

#### Acoustic setting up

- AB Base setting up
- AS Low noise setting up
- AX eXtra Low Noise setting up

#### Source temperature level

- M Medium Ambient temperature
- A High Ambient temperature





# NEWS



## > RHA HE

AIR-WATER CHILLERS AND HEAT PUMPS  
FOR OUTDOOR INSTALLATION



### Unit type

- IR Chiller
- IP Heat pump  
(reversible on the refrigerant side)
- BR Chiller Brine
- BP Heat pump Brine  
(reversible on the refrigerant side)

### Versions

- VB Base Version
- VD Desuperheater version
- VR Total Heat Recovery Version

### Acoustic setting up

- AB Base setting up
- AS Low noise setting up
- AX eXtra Low Noise setting up

### Source temperature level

- M Medium Ambient temperature
- A High Ambient temperature

EUROVENT  
CERTIFIED  
PERFORMANCE

www.eurovent-certification.com



# > Main characteristics water chillers

TECHNICAL SOLUTION  
NOISE CONFIGURATION  
HYDRAULIC SYSTEM ON THE UNIT  
SETTINGS FOR PUMPING MODULES SAFETY



## > TECHNICAL SOLUTIONS

### TYPE OF INSTALLATION

- I** for installation in hydronic systems
- B** for installation in hydronic systems with Brine solution (process application)

### OPERATION

- R** chiller
- P** reversible chiller
- W** water side reversible chiller

### VERSIONS

#### Basic Version VB

cooling only IR or heat pump IP

#### De-superheated Version VD

heat recovery only in de-superheating phases for cooling only units **IR** or heat pump units **IP**

#### Total Recovery Version VR

total heat recovery where all the thermal energy extracted by the fans is recovered by a condenser sized for the type of application

## > SOUND CONFIGURATION

### Basic Configuration AB

#### Low noise Configuration AS

Reduction in the number of fan speed with compressor insulation and a housing compartment with sound-absorbing material (fig. a).

#### Extra Low noise Configuration AX

A further reduction in the speed number due to larger exchangers.

**New-concept fans** with plastic blades and lower noise, in addition new **sound-absorbing materials** for covering the compressor and housing compartment has created a considerable noise reduction during operation (fig. b).



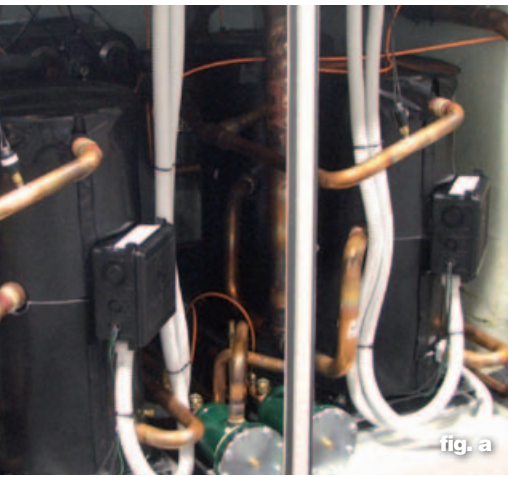

fig. a



fig. b



fig. c



## > HYDRAULIC SYSTEM ON THE UNIT

The following accessories are available to allow the unit to be configured according to the system needs:

### Storage Tank

Large capacity completely insulated and with air-vent, safety valves and drain.

### Pumping module

- available with single pump or with backup pump,
- available **with variable-flow pump**;
- up to three levels of useful static pressure are available to adapt to any system design need,
- with a storage tank fitted, this allows configuration of the tank on the system delivery or primary circuit only.

### Pumping-storage tank module

for installation next to the unit, the module is supplied complete with tank and pump or with twin pump version.

All the pumping accessories are complete with shut-off and safety valves, air vent, drain, expansion tank, one-way valves (only in case of twin pump), filter and pressure gauge for complete installation and easy service access (fig. c).

## > SETTINGS FOR PUMPING MODULES SAFETY

The research and development of advanced electronics controls has enhanced the development of regulation logics. This ensures correct operation of the pumping systems. Therefore:

### Unit with twin pump

The control system provides pump rotation to balance the hours of operation.

### Unit with twin pump

If one pump shuts down, the second pump starts automatically and the UNIT CONTROL signals the fault.

### Protection

If the unit remains on standby for long periods, the pump is started periodically to ensure correct and continuous operation.

### Anti-freeze function

With the unit in standby, the setting starts the pump if the water probe detects a temperature below a certain threshold.

**NB: please refer to each series solutions.**





# > Main characteristics water chillers

SETTING  
EUROVENT  
HIGH ESEER

## > SETTING

Qualified Ferroli internal personnel have designed, developed and inspected the control logics for management of the unit, to ensure continuous operation and always with a view to energy-saving.

Settings for the technical use of the product are designed for residential, commercial or industrial units; refer to each unit the specific settings.

### CLIMATE CONTROL FUNCTION (SLIDING TEMPERATURE)

(this function is only available in presence of outside air probe);  
in the heating mode, the Set point is adjusted according to the climatic conditions, optimising operation.  
It is also available in cooling mode, after modifying the regulator parameters,

### DYNAMIC DEFROST

(this function is only available in presence of outside air probe);  
with harsh outside temperatures, the efficiency of the system is optimised, avoiding unnecessary defrosts.

### TIME PROGRAMMING

Modifies the Set point to adapt unit operation to energy-saving.

### ECONOMY MODE

Modify the Set point to move the unit operation into energy saving mode.

### DOUBLE SET POINT

In cooling or heat pump mode the Set Point can be changed to a second value controlled by keyboard.

### ADVANCED TEMPERATURE CONTROL (ATC)

In cooling mode, with outside temperatures above the limits, ATC prevents unit shut down by modulating the compressor steps, keeping the system active to ensure its continuous operation.

### DEMAND LIMIT

Enables capacity control of the unit's maximum power absorption.

### HEATING INTEGRATIVE

In the heat pump mode a heat generator (a conventional or condensing boiler) can be activated, for integration.

### NOISE CONTROL

For multi-circuit Extra low noise units (AX), one of the circuits is saturated to minimise fan noise. The control system provides for a regulation logic enabling this system to be Low noise as much as possible.

## > EUROVENT

Ferroli is associated with formula  
**CERTIFY ALL**



Products and certification rules are present on the site:

[www.eurovent-certification.com](http://www.eurovent-certification.com)

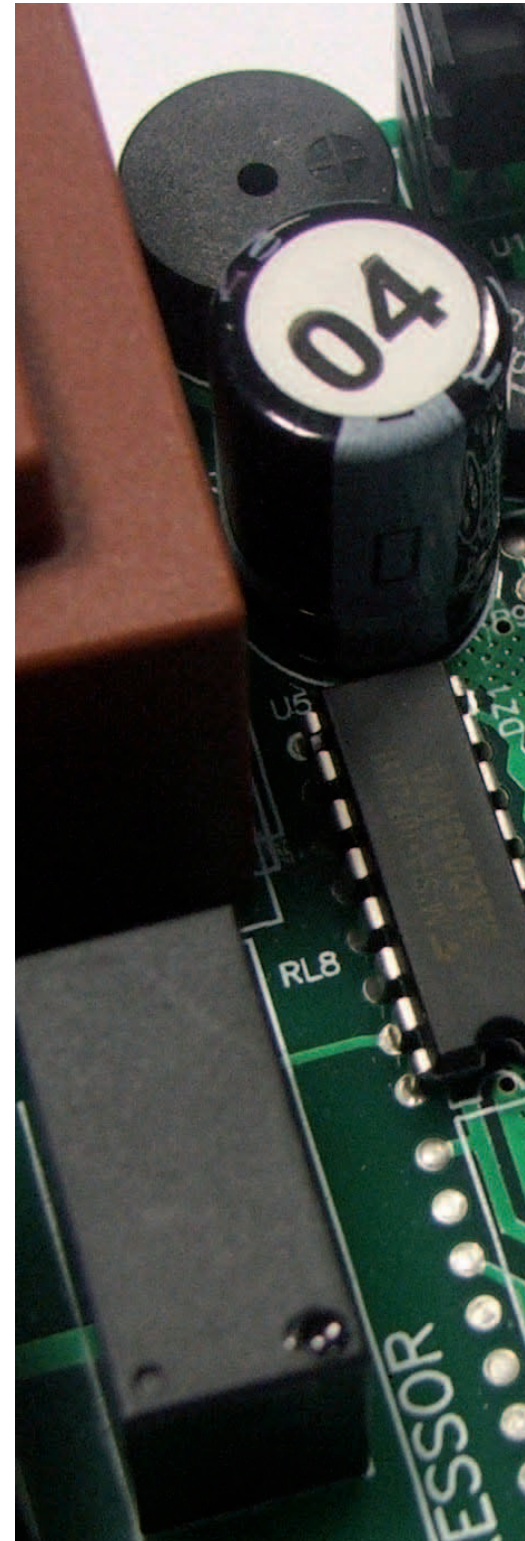



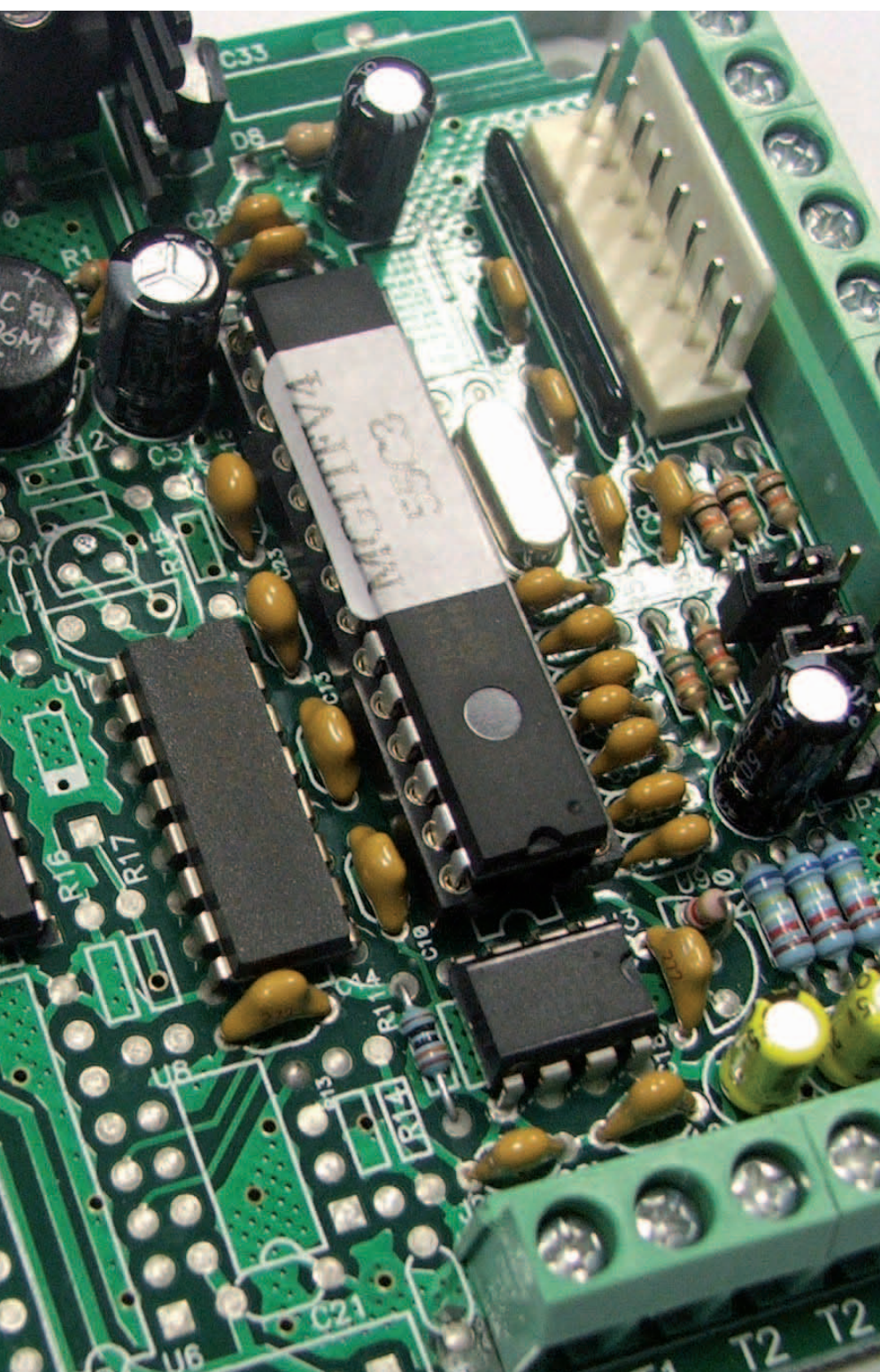

## > HIGH ESEER

ESEER is calculated as follows:  
 $ESEER = A \times EER_{100\%} + B \times EER_{75\%} + C \times EER_{50\%} + D \times EER_{25\%}$

With the following weighting coefficients:

- A = 0,03 EER 100% amb. air 35°C
- B = 0,33 EER 75% amb. air 30°C
- C = 0,41 EER 50% amb. air 25°C
- D = 0,23 EER 25% amb. air 20°C

These coefficients indicate the significance and importance of the EER value according to the load and outside temperature.

Based on EUROVENT conditions, in a normal work cycle the units work at full load (35°C) for only 3% of the time.

A better capacity control of power delivered or absorbed at partial loads involves higher seasonal efficiencies.

Choice of unit should also take into account the ESEER value because it reflects the overall unit operation.

FERROLI follows this philosophy with Multiscroll solutions and Twin-screw compressors.

Single-circuit Double compressor units with multi stages have higher ESEER values than similar units Dual circuit type. For screw type double compressors units, the saturation of circuits occurs in parallel.

Everything converts into high efficiency at partial loads and therefore significant ESEER values are achieved.

**NB: please refer to each series-specific adjustments.**



# > Main characteristics water chillers

SAFETY  
RELIABILITY  
CAREFUL DETAILS  
RESPECTING THE ENVIRONMENT  
AQUASEL

## > SAFETY

The units as standard are complete with:

- differential pressure switch on the plate-type exchanger,
- antifreeze heater on the plate-type exchanger,
- compressor high temperature protection,
- PED safety valve

Available as accessories:

- condensation control (standard on some units),
- water flowswitch
- voltage monitor and sequence meter

## > RELIABILITY

The design components chosen are highly reliable and the suppliers are all certified according to the current quality systems.

## > CAREFUL DETAILS

Particular attention to the arrangement of the main components in the design stage, careful and scheduled testing, and the important stage of final production, ensure systems that are easy serviceable and guarantee a lasting high performance package.

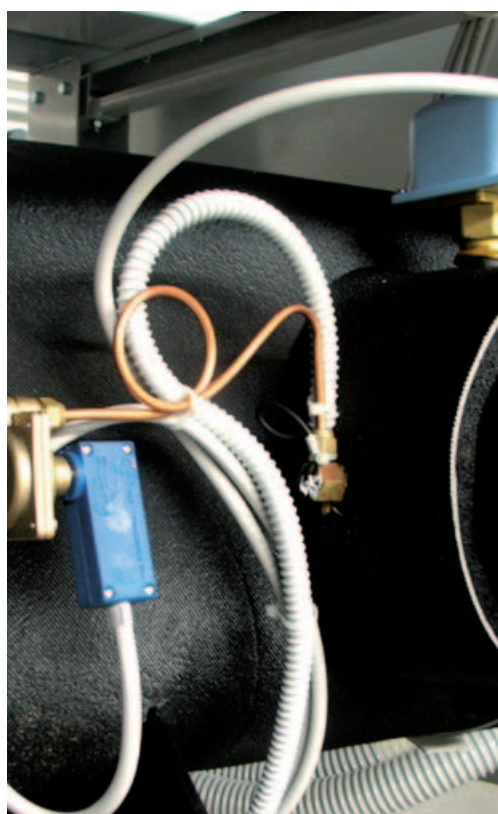

> RESPECTING ENVIRONMENT

Use of ecological refrigerant gases (ODP equal to 0) for obtaining optimum performance and **DO NOT** harm the ozone.



> AQUASEL

The Ferrol design staff have developed software for choosing the right unit for your system needs, calculating the performance values according to the air and water temperature, depending on the model or acoustic version.

There is also the selected choice of accessories the printing of the description of the unit's specifications and a complete technical data sheet.

At the end of selection the customer can have a list price or net price with discounts of all the selected units.

A sales tool much appreciated by professionals for its easy use and prompt answers.

**For more information contact Ferrol Air conditioning Industrial department**

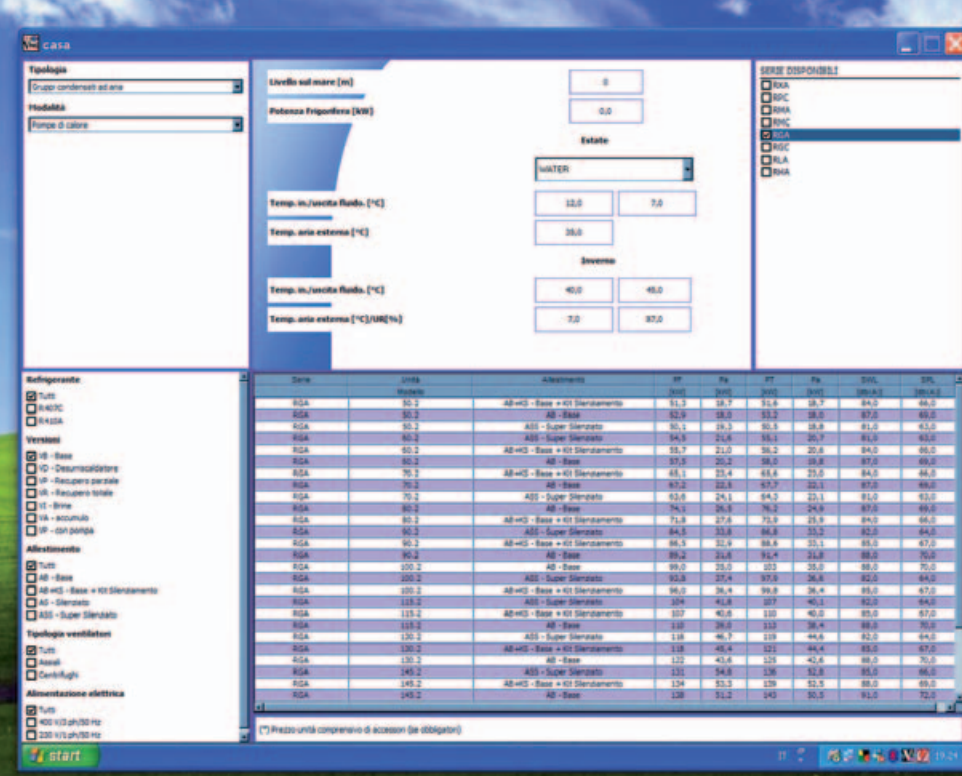
The screenshot shows the AQUASEL software interface. It includes input fields for 'Livello sul mare (m)', 'Potenza frigorifera (kW)', and temperature settings for 'Estate' and 'Inverno'. A table of available units is displayed with columns for 'Serie', 'Unità', 'Accessori', 'IP', 'Pa', 'PT', 'Pa', 'DIN', and 'DIN'. The table lists various models such as RGA, RGA Super Silenzioso, and RGA Base, along with their corresponding performance metrics.

Serie	Unità	Accessori	IP	Pa	PT	Pa	DIN	DIN
RGA	50.0	AB-w3 - Base + 01 Silenzioso	50.0	50.0	50.0	50.0	50.0	50.0
RGA	50.0	AB - Base	52.9	53.0	53.2	53.0	57.0	59.0
RGA	50.0	AB - Super Silenzioso	50.0	50.0	50.0	50.0	51.0	53.0
RGA	50.0	AB - Super Silenzioso	54.0	54.0	54.0	54.0	54.0	54.0
RGA	50.0	AB-w3 - Base + 01 Silenzioso	58.7	59.0	59.2	59.0	64.0	66.0
RGA	50.0	AB - Base	57.0	57.0	57.0	57.0	57.0	57.0
RGA	70.0	AB-w3 - Base + 01 Silenzioso	68.0	68.0	68.0	68.0	74.0	76.0
RGA	70.0	AB - Base	67.0	67.0	67.0	67.0	70.0	72.0
RGA	70.0	AB - Super Silenzioso	63.0	63.0	63.0	63.0	63.0	63.0
RGA	80.0	AB - Base	74.0	74.0	74.0	74.0	77.0	79.0
RGA	80.0	AB-w3 - Base + 01 Silenzioso	71.0	71.0	71.0	71.0	74.0	76.0
RGA	80.0	AB - Super Silenzioso	64.0	64.0	64.0	64.0	64.0	64.0
RGA	80.0	AB-w3 - Base + 01 Silenzioso	68.0	68.0	68.0	68.0	71.0	73.0
RGA	90.0	AB - Base	89.0	89.0	89.0	89.0	92.0	94.0
RGA	100.0	AB - Super Silenzioso	93.0	93.0	93.0	93.0	93.0	93.0
RGA	100.0	AB-w3 - Base + 01 Silenzioso	96.0	96.0	96.0	96.0	99.0	101.0
RGA	100.0	AB - Super Silenzioso	94.0	94.0	94.0	94.0	94.0	94.0
RGA	110.0	AB-w3 - Base + 01 Silenzioso	107.0	107.0	107.0	107.0	110.0	112.0
RGA	110.0	AB - Base	105.0	105.0	105.0	105.0	108.0	110.0
RGA	110.0	AB - Super Silenzioso	100.0	100.0	100.0	100.0	100.0	100.0
RGA	120.0	AB-w3 - Base + 01 Silenzioso	118.0	118.0	118.0	118.0	121.0	123.0
RGA	120.0	AB - Base	116.0	116.0	116.0	116.0	119.0	121.0
RGA	130.0	AB-w3 - Base + 01 Silenzioso	128.0	128.0	128.0	128.0	131.0	133.0
RGA	130.0	AB - Base	126.0	126.0	126.0	126.0	129.0	131.0
RGA	140.0	AB - Super Silenzioso	131.0	131.0	131.0	131.0	131.0	131.0
RGA	140.0	AB-w3 - Base + 01 Silenzioso	134.0	134.0	134.0	134.0	137.0	139.0
RGA	140.0	AB - Base	132.0	132.0	132.0	132.0	135.0	137.0



# > Main characteristics water chillers

## CHILLERS SEQUENCER

Capacity control of system become a major point of discussion both in the design stage and that of production.

The Ferroli design team, has developed a logic control that allows you to manage and monitor the operation of more chiller to serve a single plant.

### > CHILLERS SEQUENCER

The controller, suitable for internal installation within a heating plant, as standard feature such as an electrical panel, (housed in a sheet metal enclosure) and complete with a main disconnecting switch, LEDs for displaying alarms and operation status (ON/OFF), manual summer/winter selector (provided for units with heat pump) and manual ON/OFF selector plus a large display for unit programming. A terminal block is fitted on a metal plate inside the panel to facilitate unit connections. The system comes standard complete with a telescopic-type water probe (picture below), IP65 protection rating, to facilitate reading the delivery temperature of the water inside the header or the hydraulic separator.

NTC-type sensitive element.

The sensor element is of the NTC.

System programming is designed to be clear and easy. Various menus can be accessed by buttons on the display for setting and programming management of the control system and units. Through the LCD display the following is possible:

- programming operation times,
- selecting the date and time,
- programming a holiday period,
- monitoring and modification of temperatures,
- monitoring and modification of control outputs,
- monitoring and modification of set-point,
- monitoring system status.

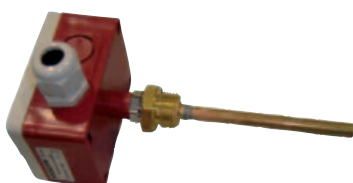

#### ■ MANAGEMENT OF SEVERAL UNITS WITH PRIMARY PUMP

For correct system management the 3GFC and 6GFC controllers can control one pump (only 3GFC) or one twin pump (only 6GFC) serving the primary circuit if the units do not have them, as indicated in the example in figure A.

In this case the units are type **RMA VB AB 0M5** configured with just the pipe kit and connected in parallel. They are fed by a single pump. The choice of delivery pump is to the installer or designer. Pump electrical protection and power supply installation are the installer's responsibility.

#### ■ MANAGEMENT OF UNITS WITH DOUBLE PRIMARY PUMP

Fig. A-1 implies the use of a 6GFC type panel enabling management of a twin pump serving the primary circuit.

NB: All the pumping accessories are complete with shut-off and safety valves, air vent, drain, expansion tank, one-way valves (only in case of twin pump), filter and pressure gauge for complete installation and easy service access.

All these components are the installer's responsibility.

The pumps electrical protection and power supply installation are the installer's responsibility.

#### Suggested connection diagram

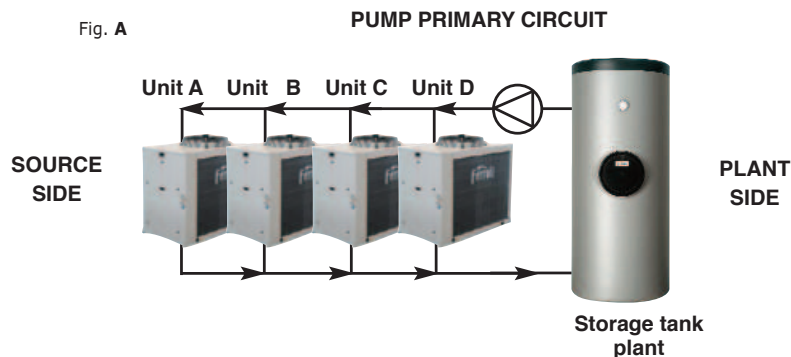
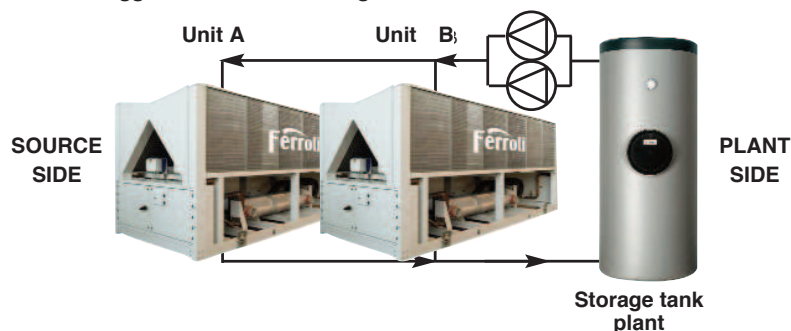

Fig. A-1

#### Suggested connection diagram



Connecting several units in cascade involves the calculation of a pumping system that correctly feeds each exchanger with the correct water flow-rate value given in the technical data of the units.

Qualified Ferroli personnel are available upon request to provide the delivery and pressure loss data of the units.

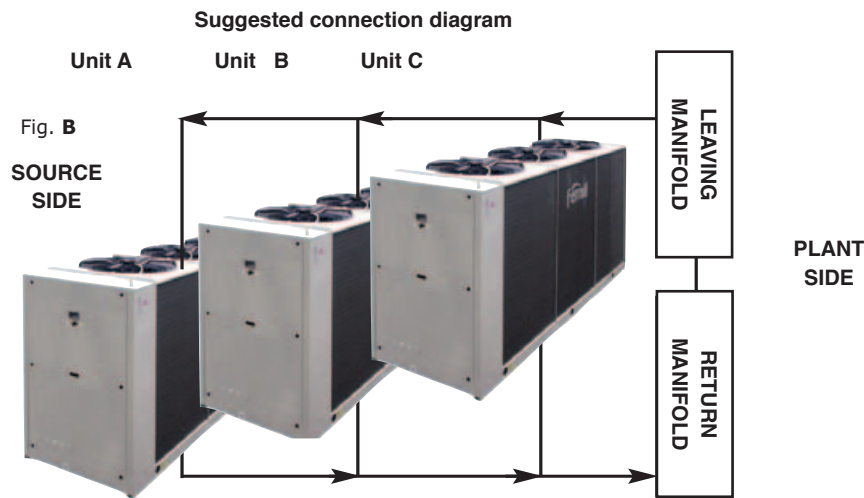

#### ■ MANAGEMENT OF UNITS WITH PUMP FITTED INSIDE (ACCESSORY)

The Ferroli range encompasses (as an accessory when available), a range of pumping modules with tank, serving only the primary circuit (consisting of tank-pump-plate type exchanger) controlled directly by the micro-processor control.

This solution, as indicated in the example in figure B, enables the correct distribution of water even in the case of several units. The tank-pump (accessory) system is installed and tested at the factory.

NB: In specific cases, for correct operation and maintenance of the hydronic circuit all the components are fitted standard inside the unit (refer to the item "pumping modules" in the guide).

The installer only has to ensure the hydraulic connection of the units and the various electrical connections.

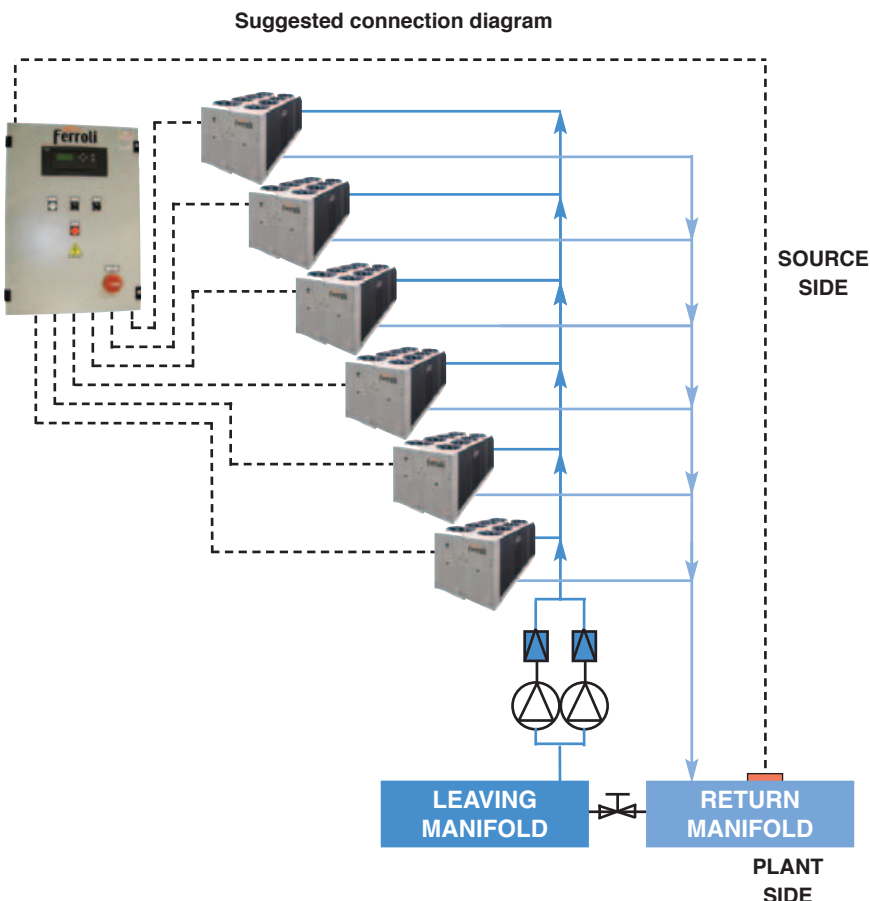

#### ■ MANAGEMENT OF UNITS WITH PUMP FITTED INSIDE (ACCESSORY)

In the case opposite, six RLA units configured with just the Pipe Kit are connected to a 6GFC system.

The electrical panel controls the six units and the single or twin pump.

The pumps electrical protection and power supply installation are the installer's responsibility. The pumping system must be provided with a one-way valve (in case of twin pump), mesh filter, system calibration valves, expansion tank, safety valve and anything else necessary to make the system operational and easily serviced.

#### ■ UNIT CONSENT MANAGEMENT

All the electrical connections for activation consent and for management of the units must be taken to the electrical panel and an NTC probe, supplied standard, and must be connected for the system water temperature reading.

# > RXA

## AIR-WATER CHILLERS AND HEAT PUMPS FOR OUTDOOR INSTALLATION



### Available range

#### Unit type

- IR Chiller
- IP Heat pump  
(reversible on the refrigerant side)

#### Versions

- VB Base Version
- VP Pump version
- VA Tank version

#### Acoustic setting up

- AB Base setting up

### Unit description

This series of air-water chillers and heat pumps satisfies the cooling and heating requirements of residential plants of small and medium size.

All the units are suitable for outdoor installation and can be applied to fan coil plants, radiant floor plants and high efficiency radiators plants.

The refrigerant circuit, contained in a compartment protected from the air flow to simplify the maintenance operations, is equipped with rotary or scroll compressor (according to the model) mounted on damper supports, brazed plate heat exchanger, thermostatic expansion

valve, reverse cycle valve, axial fans with safety protection grilles, finned coil made of copper pipes and aluminium louvered fins. The circuit is protected by high and low pressure switches and differential pressure switch on the plate heat exchanger.

The plate heat exchanger and all the hydraulic pipes are thermally insulated in order to avoid condensate generation and to reduce thermal losses.

All the units are equipped with variable speed fans control that allows the units to operate with low outdoor temperatures in cooling and high outdoor temperature in heating and permits to reduce noise emissions in such operating conditions.

All the units are supplied with an outdoor temperature sensor, already installed on the unit, in order to realize the climatic control.

All three-phase power supply units are provided with a phase presence and correct sequence controller device.

All the units are accurately built and individually tested in the factory. Only electric and hydraulic connections are required for installation.

### Options

#### Storing and pumping module

- not present (VB - base version)
- standard, high head or modulating pump (VP - pump version)
- tank and standard, high head or modulating pump (VA - tank version)

#### Integrative electrical heaters

- standard in the flow  
(only VB and VP versions)
- standard in the tank  
(only VA version)
- upsized in the tank  
(only VA version)

#### Compressor starting

- standard (contactors)
- soft starter

### Accessories

Rubber vibration dampers

Coil protection grille

Tank antifreeze electrical heater

Remote control

Modbus serial interface on RS485

Programmer clock

Phase sequence and voltage controller



**NET NOMINAL performances - Standard plants - EUROVENT certified data**

IR	Base setting up (AB)	6.1	7.1	9.1	11.1	14.1	17.1	
<b>A35W7</b>	Cooling capacity	6,24	7,24	9,12	10,6	14,1	16,7	kW
	Power input	2,31	2,81	3,52	4,16	5,25	6,49	kW
	<b>EER</b>	<b>2,70</b>	<b>2,58</b>	<b>2,59</b>	<b>2,55</b>	<b>2,69</b>	<b>2,57</b>	<b>W/W</b>
	<b>ESEER</b>	<b>3,23</b>	<b>2,92</b>	<b>2,83</b>	<b>2,93</b>	<b>3,02</b>	<b>2,92</b>	<b>W/W</b>
	Water flow rate	0,30	0,35	0,44	0,51	0,68	0,80	l/s
	Pressure drops	17	21	31	40	43	39	kPa
<b>IP</b>	<b>Base setting up (AB)</b>	<b>6.1</b>	<b>7.1</b>	<b>9.1</b>	<b>11.1</b>	<b>14.1</b>	<b>17.1</b>	
<b>A35W7</b>	Cooling capacity	6,12	7,10	8,95	10,4	13,8	16,4	kW
	Power input	2,31	2,81	3,51	4,15	5,24	6,49	kW
	<b>EER</b>	<b>2,65</b>	<b>2,53</b>	<b>2,55</b>	<b>2,51</b>	<b>2,63</b>	<b>2,53</b>	<b>W/W</b>
	<b>ESEER</b>	<b>3,11</b>	<b>2,79</b>	<b>2,76</b>	<b>2,88</b>	<b>2,98</b>	<b>2,89</b>	<b>W/W</b>
	Water flow rate	0,29	0,34	0,43	0,50	0,66	0,79	l/s
	Pressure drops	16	20	30	39	42	38	kPa
<b>A7W45</b>	Heating capacity	6,78	7,87	9,95	11,7	15,4	18,2	kW
	Power input	2,22	2,71	3,38	4,01	5,06	6,25	kW
	<b>COP</b>	<b>3,05</b>	<b>2,90</b>	<b>2,94</b>	<b>2,92</b>	<b>3,04</b>	<b>2,91</b>	<b>W/W</b>
	Water flow rate	0,32	0,37	0,47	0,55	0,73	0,86	l/s
	Pressure drops	18	24	35	45	48	43	kPa

**NET NOMINAL performances - Radiant plants**

IR	Base setting up (AB)	6.1	7.1	9.1	11.1	14.1	17.1	
<b>A35W18</b>	Cooling capacity	7,48	8,67	10,9	12,7	16,8	20,0	kW
	Power input	2,39	2,91	3,64	4,32	5,46	6,75	kW
	<b>EER</b>	<b>3,13</b>	<b>2,98</b>	<b>2,99</b>	<b>2,94</b>	<b>3,08</b>	<b>2,96</b>	<b>W/W</b>
	Water flow rate	0,36	0,42	0,52	0,61	0,81	0,96	l/s
	Pressure drops	22	29	42	53	58	53	kPa
<b>IP</b>	<b>Base setting up (AB)</b>	<b>6.1</b>	<b>7.1</b>	<b>9.1</b>	<b>11.1</b>	<b>14.1</b>	<b>17.1</b>	
<b>A35W18</b>	Cooling capacity	7,34	8,50	10,7	12,5	16,6	19,6	kW
	Power input	2,39	2,91	3,64	4,31	5,45	6,74	kW
	<b>EER</b>	<b>3,07</b>	<b>2,92</b>	<b>2,94</b>	<b>2,90</b>	<b>3,05</b>	<b>2,91</b>	<b>W/W</b>
	Water flow rate	0,35	0,41	0,52	0,60	0,80	0,94	l/s
	Pressure drops	22	28	41	52	56	51	kPa
<b>A7W35</b>	Heating capacity	6,92	8,03	10,2	11,9	15,7	18,6	kW
	Power input	1,87	2,28	2,86	3,39	4,27	5,28	kW
	<b>COP</b>	<b>3,70</b>	<b>3,52</b>	<b>3,57</b>	<b>3,51</b>	<b>3,68</b>	<b>3,52</b>	<b>W/W</b>
	Water flow rate	0,33	0,38	0,48	0,56	0,74	0,88	l/s
	Pressure drops	19	25	36	47	50	46	kPa

Data declared according to **EN 14511**. The values are referred to units without options and accessories.

**EER** (Energy Efficiency Ratio) = ratio of the total cooling capacity to the effective power input of the unit

**COP** (Coefficient Of Performance) = ratio of the total heating capacity to the effective power input of the unit

**ESEER** (European Seasonal Energy Efficiency Ratio) = Unit in **A CLASS**.

**A35W7** = source : air in 35°C d.b. / plant : water in 12°C out 7°C

**A35W18** = source : air in 35°C d.b. / plant : water in 23°C out 18°C

**A7W45** = source : air in 7°C d.b. 6°C w.b. / plant : water in 40°C out 45°C

**A7W35** = source : air in 7°C d.b. 6°C w.b. / plant : water in 30°C out 35°C

### Acoustic performances

Base setting up (AB)	6.1	7.1	9.1	11.1	14.1	17.1	
Sound power level <sup>(E)</sup>	69	69	72	72	74	74	dB(A)
Sound pressure level at 1 meter	55	55	57	57	59	59	dB(A)
Sound pressure level at 5 meters	44	44	46	46	48	48	dB(A)
Sound pressure level at 10 meters	38	38	41	41	43	43	dB(A)

(E): EUROVENT certified data

The acoustic performances are referred to units operating in cooling mode at nominal conditions A35W7.

Unit placed in free field on reflecting surface (directional factor equal to 2).

The sound power level is measured according to ISO 9614 standard.

The sound pressure level is calculated according to ISO 3744 and is referred to a distance of 1/5/10 metres from the external surface of the unit.

### Technical data

Unit	6.1	7.1	9.1	11.1	14.1	17.1	
Power supply	230 - 1 - 50		230 - 1 - 50 400 - 3N - 50		400 - 3N - 50		V-ph-Hz
Compressor type	rotative		scroll				-
N° compressors / N° refrigerant circuits	1 / 1						n°
Plant side heat exchanger type	stainless steel brazed plates						-
Source side heat exchanger type	finned coil						-
Fans type	axial						-
N° fans	1						n°
Tank volume	33		50		71		l
Hydraulic fittings	1" M						-

### Electrical data

Standard unit	6.1	7.1	9.1	11.1	14.1	17.1	
Power supply	230 - 1 - 50	230 - 1 - 50	230 - 1 - 50 / 400 - 3N - 50	230 - 1 - 50 / 400 - 3N - 50	400 - 3N - 50	400 - 3N - 50	V-ph-Hz
<b>FLA</b> - Full load current at maximum tolerated conditions	13,4	17,1	22,0 / 8,1	24,8 / 9,0	11,1	13,9	A
<b>FLI</b> - Full load power input at maximum tolerated conditions	2,9	3,7	4,7 / 4,7	5,3 / 5,3	6,2	8,0	kW
<b>MIC</b> - Maximum instantaneous current of the unit	82	112	141 / 54	174 / 69	87	106	A
<b>MIC SS</b> - Maximum instantaneous current of the unit with soft starter options	41	43	49 / 33	59 / 40	48	55	A
Unit with high head modulating pump	6.1	7.1	9.1	11.1	14.1	17.1	
Power supply	230 - 1 - 50	230 - 1 - 50	230 - 1 - 50 / 400 - 3N - 50	230 - 1 - 50 / 400 - 3N - 50	400 - 3N - 50	400 - 3N - 50	V-ph-Hz
<b>FLA</b> - Full load current at maximum tolerated conditions	14.4	18.1	23.3 / 9.4	26.1 / 10.3	12.9	15.7	A
<b>FLI</b> - Full load power input at maximum tolerated conditions	3.1	3.9	4.95 / 4.95	5.55 / 5.55	6.55	8.35	kW
<b>MIC</b> - Maximum instantaneous current of the unit	83	113	142.3 / 55.3	175.3 / 70.3	88.8	107.8	A
<b>MIC SS</b> - Maximum instantaneous current of the unit with soft starter options	42	44	50.3 / 34.3	60.3 / 41.3	49.8	56.8	A

### Operative range

Temperature	Unit type	Cooling		Heating		
		min	max	min	max	
Outdoor air inlet temperature	IR, IP	-10	48	-15	42	°C
Water outlet temperature	IR, IP	5	25	30	55	°C

## CONTROL SYSTEM

The unit is managed by a microprocessor controller to which, through a wiring board, all the electrical loads and the control devices are connected. The user interface is realized by a display and four buttons that allow to view and, if necessary, modify all the operating parameters of the unit. It's available, as an accessory, a remote control that reports all the functionalities of the user interface placed on the unit.

The main functions available are :

- water temperature management (through set point adjustment)
- climatic control in heating and in cooling mode (automatic set point adjustment according to outdoor air temperature)
- dynamic defrost cycle management according to outdoor air temperature
- alarm memory management and diagnostic

- fans management by means of continuous rotational speed control
- pump management
- integrative electrical heaters management in heating mode (2 step logic)
- compressor and pump operating hours recording
- serial communication through Modbus protocol
- remote stand by
- remote cooling-heating
- general alarm digital output



## DIMENSIONS AND MINIMUM OPERATING AREA

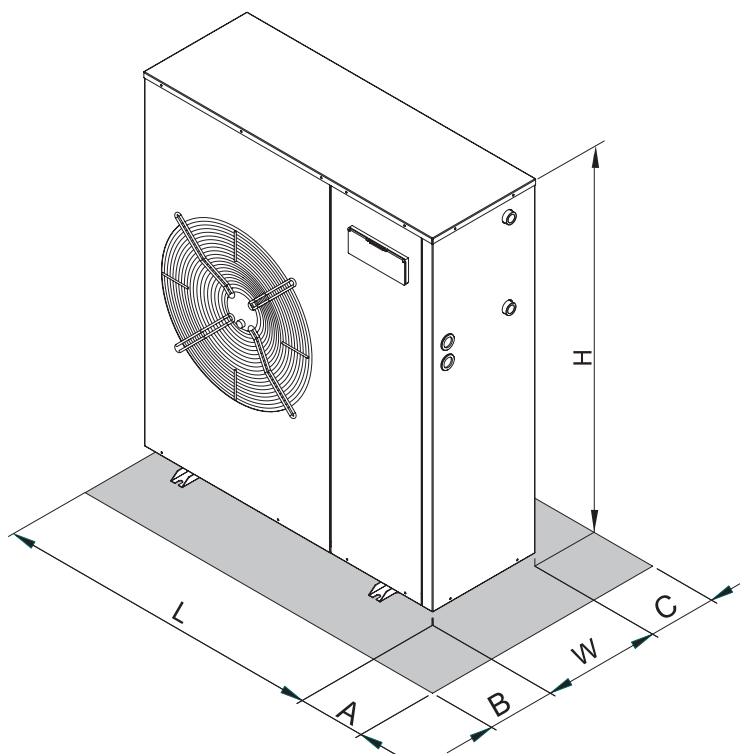

	Version	6.1	7.1	9.1	11.1	14.1	17.1	
L	VB - VP	994	994	994	994	994	994	mm
	VA	1329	1329	1329	1329	1329	1329	mm
W	-	356	356	356	356	356	356	mm
H	-	903	903	1153	1153	1453	1453	mm
A	-	400	400	400	400	400	400	mm
B	-	600	600	600	600	600	600	mm
C	-	200	200	200	200	200	200	mm
Operating maximum weight*	VA	164	171	220	238	285	294	kg



# > RMA

## AIR-WATER CHILLERS AND HEAT PUMPS FOR OUTDOOR INSTALLATION



### Available range

#### Unit type

IR	Chiller
IP	Heat pump (reversible on the refrigerant side)
BR	Chiller Brine
BP	Heat pump Brine (reversible on the refrigerant side)

#### Versions

VB	Base Version
VP	Pump version
VA	Tank version

#### Acoustic setting up

AB	Base setting up
AS	Low noise setting up

### Unit description

This series of air-water chillers and heat pumps satisfies the cooling and heating requirements of residential plants of small and medium size.

All the units are suitable for outdoor installation and can be applied to fan coil plants, radiant floor plants and high efficiency radiators plants.

The refrigerant circuit, contained in a compartment protected from the air flow to simplify the maintenance operations, is equipped with scroll compressor mounted

on damper supports, brazed plate heat exchanger, thermostatic expansion valve, reverse cycle valve, axial fans with safety protection grilles, finned coil made of copper pipes and aluminium louvered fins. The circuit is protected by high and low pressure switches and differential pressure switch on the plate heat exchanger.

The plate heat exchanger and all the hydraulic pipes are thermally insulated in order to avoid condensate generation and to reduce thermal losses.

All the units can be equipped with variable speed fans control that allows the units to operate with low outdoor temperatures in cooling and high outdoor temperature in heating and permits to reduce noise emissions in such operating conditions.

The low noise acoustic setting up (AS) is obtained, starting from the base setting up (AB), reducing the rotational speed of the fans and mounting sound jackets on the compressors.

All the units are supplied with an outdoor temperature sensor, already installed on the unit, in order to realize the climatic control.

All the units are provided with a phase presence and correct sequence controller device.

All the units are accurately built and individually tested in the factory. Only electric and hydraulic connections are required for installation.

### Options

#### Storing and pumping module

- not present (VB - base version)
- standard, high head or modulating pump (VP - pump version)
- tank and standard, high head or modulating pump (VA - tank version)

#### Integrative electrical heaters

- not present
- standard in the tank

#### Compressor starting

- standard (contactors)
- soft starter

#### Fans control

- on-off control
- modulating control (condensation / evaporation control) standard for AS unit

#### Electrical loads protection

- fuses
  - thermal magnetic circuit breakers
- #### Compressor power factor correction

### Accessories

Rubber vibration dampers

Coil protection grille

Tank antifreeze electrical heater

Remote control

Modbus serial interface on RS485

Programmer clock

Phase sequence and voltage controller

**NET NOMINAL performances - Standard plants - EUROVENT certified data**

IR	Base setting up (AB)	19.1	22.1	26.1	30.1	35.1	40.1	
A35W7	Cooling capacity	19,9	22,1	25,8	30,8	35,6	40,2	kW
	Power input	6,82	7,50	8,76	10,8	12,3	13,9	kW
	EER	2,92	2,95	2,95	2,85	2,89	2,89	W/W
	ESEER	3,26	3,29	3,28	3,20	3,24	3,23	W/W
	Water flow rate	0,953	1,06	1,23	1,48	1,71	1,93	l/s
	Pressure drops	26	31	26	36	31	38	kPa
IR	Low noise setting up (AS)	19.1	22.1	26.1	30.1	35.1	40.1	
A35W7	Cooling capacity	19,1	21,2	24,8	29,6	34,2	38,6	kW
	Power input	7,34	8,09	9,42	11,6	13,3	15,0	kW
	EER	2,60	2,62	2,63	2,55	2,57	2,57	W/W
	ESEER	2,89	2,93	2,93	2,86	2,88	2,87	W/W
	Water flow rate	0,915	1,02	1,19	1,42	1,64	1,85	l/s
	Pressure drops	24	29	24	33	28	36	kPa
IP	Base setting up (AB)	19.1	22.1	26.1	30.1	35.1	40.1	
A35W7	Cooling capacity	19,5	21,7	25,3	30,2	34,9	39,4	kW
	Power input	6,75	7,42	8,66	10,7	12,2	13,8	kW
	EER	2,89	2,92	2,92	2,82	2,86	2,86	W/W
	ESEER	3,22	3,27	3,26	3,18	3,21	3,19	W/W
	Water flow rate	0,934	1,04	1,21	1,45	1,67	1,89	l/s
	Pressure drops	25	30	25	35	29	37	kPa
A7W45	Heating capacity	21,0	23,3	27,1	32,5	37,6	42,4	kW
	Power input	6,49	7,14	8,33	10,3	11,7	13,4	kW
	COP	3,24	3,26	3,25	3,16	3,21	3,16	W/W
	Water flow rate	0,991	1,10	1,28	1,53	1,77	2,00	l/s
Pressure drops	27	33	27	38	33	41	kPa	
IP	Low noise setting up (AS)	19.1	22.1	26.1	30.1	35.1	40.1	
A35W7	Cooling capacity	18,7	20,8	24,3	29,1	33,6	37,8	kW
	Power input	7,27	8,00	9,33	11,4	13,1	14,9	kW
	EER	2,57	2,60	2,60	2,55	2,56	2,54	W/W
	ESEER	2,86	2,89	2,89	2,83	2,84	2,84	W/W
	Water flow rate	0,896	1,00	1,16	1,39	1,61	1,81	l/s
	Pressure drops	23	28	23	32	27	34	kPa
A7W45	Heating capacity	19,9	22,2	25,8	31,0	35,8	40,3	kW
	Power input	6,22	6,85	7,98	9,88	11,3	12,8	kW
	COP	3,20	3,24	3,23	3,14	3,17	3,15	W/W
	Water flow rate	0,939	1,05	1,22	1,46	1,69	1,90	l/s
Pressure drops	25	30	25	35	30	37	kPa	

**NET NOMINAL performances - Radiant plants**

IR	Base setting up (AB)	19.1	22.1	26.1	30.1	35.1	40.1	
A35W18	Cooling capacity	24,6	27,3	31,9	38,1	44,1	49,6	kW
	Power input	7,09	7,81	9,11	11,2	12,8	14,6	kW
	EER	3,47	3,50	3,50	3,40	3,45	3,40	W/W
	Water flow rate	1,18	1,31	1,53	1,83	2,12	2,39	l/s
	Pressure drops	39	47	38	54	46	58	kPa
IP	Base setting up (AB)	19.1	22.1	26.1	30.1	35.1	40.1	
A35W18	Cooling capacity	24,2	26,8	31,3	37,4	43,2	48,7	kW
	Power input	7,01	7,73	9,01	11,1	12,7	14,4	kW
	EER	3,45	3,47	3,47	3,37	3,40	3,38	W/W
	Water flow rate	1,16	1,29	1,50	1,80	2,08	2,34	l/s
	Pressure drops	37	45	37	52	44	56	kPa
A7W35	Heating capacity	21,40	23,80	27,70	33,20	38,40	43,30	kW
	Power input	5,48	6,03	7,03	8,71	9,91	11,30	kW
	COP	3,91	3,95	3,94	3,81	3,87	3,83	W/W
	Water flow rate	1,01	1,13	1,31	1,57	1,82	2,05	l/s
Pressure drops	29	35	29	40	34	43	kPa	

Data declared according to **EN 14511**. The values are referred to units without options and accessories.  
**EER** (Energy Efficiency Ratio) = ratio of the total cooling capacity to the effective power input of the unit  
**COP** (Coefficient Of Performance) = ratio of the total heating capacity to the effective power input of the unit

**ESEER** (European Seasonal Energy Efficiency Ratio) = Unit in **A CLASS**.

**A35W7** = source : air in 35°C d.b. / plant : water in 12°C out 7°C  
**A35W18** = source : air in 35°C d.b. / plant : water in 23°C out 18°C  
**A7W45** = source : air in 7°C d.b. 6°C w.b. / plant : water in 40°C out 45°C  
**A7W35** = source : air in 7°C d.b. 6°C w.b. / plant : water in 30°C out 35°C

### Acoustic performances

Base setting up (AB)	19.1	22.1	26.1	30.1	35.1	40.1	
Sound power level <sup>(E)</sup>	77	77	78	81	82	82	dB(A)
Sound pressure level at 1 meter	61	62	62	65	66	66	dB(A)
Sound pressure level at 5 meters	51	51	52	55	55	56	dB(A)
Sound pressure level at 10 meters	46	46	47	50	50	50	dB(A)
Low noise setting up (AS)	19.1	22.1	26.1	30.1	35.1	40.1	
Sound power level <sup>(E)</sup>	74	74	75	78	79	79	dB(A)
Sound pressure level at 1 meter	58	59	59	62	63	63	dB(A)
Sound pressure level at 5 meters	48	48	49	52	53	53	dB(A)
Sound pressure level at 10 meters	43	43	44	47	48	48	dB(A)

#### (E): EUROVENT certified data

The acoustic performances are referred to units operating in cooling mode at nominal conditions A35W7.

Unit placed in free field on reflecting surface (directional factor equal to 2).

The sound power level is measured according to ISO 9614 standard.

The sound pressure level is calculated according to ISO 3744 and is referred to a distance of 1/5/10 metres from the external surface of the unit.

### Technical data

Unit	19.1	22.1	26.1	30.1	35.1	40.1	
Power supply	400 - 3+N - 50						V-ph-Hz
Compressor type	scroll						-
N° compressors / N° refrigerant circuits	1 / 1						n°
Plant side heat exchanger type	stainless steel brazed plates						-
Source side heat exchanger type	finned coil						-
Fans type	axial						-
N° fans	1						n°
Tank volume	85						l
Hydraulic fittings	1"1/4 VICTAULIC						-

### Electrical data

Standard unit	19.1	22.1	26.1	30.1	35.1	40.1	
<b>FLA</b> - Full load current at maximum tolerated conditions	18,8	20,8	22,9	25,9	29,9	34,0	A
<b>FLI</b> - Full load power input at maximum tolerated conditions	10,8	12,1	13,4	15,8	18,4	21,0	kW
<b>MIC</b> - Maximum instantaneous current of the unit	98	114	121	129	144	178	A
<b>MIC SS</b> - Maximum instantaneous current of the unit with soft starter options	55	64	68	73	82	102	A
Unit with high head modulating pump	19.1	22.1	26.1	30.1	35.1	40.1	
<b>FLA</b> - Full load current at maximum tolerated conditions	24,9	26,9	29,0	32,0	38,1	42,2	A
<b>FLI</b> - Full load power input at maximum tolerated conditions	12,0	13,3	16,6	17,0	20,0	26,1	kW
<b>MIC</b> - Maximum instantaneous current of the unit	104,1	120,1	127,1	135,1	152,2	186,2	A
<b>MIC SS</b> - Maximum instantaneous current of the unit with soft starter options	61,1	70,1	74,1	79,1	90,2	110,2	A

### Operating range

Temperatura	Unit type	Cooling		Heating		
		min	max	min	max	
Outdoor air inlet temperature	IR, BR, IP, BP	-10*	48	-15	42	(°C)
Water outlet temperature	IR, IP	5	25	30	55	(°C)
Water outlet temperature	BR, BP	-12	25	30	55	(°C)

\* with fans modulating control option (condensation / evaporation control)



## CONTROL SYSTEM

The unit is managed by a microprocessor controller to which, through a wiring board, all the electrical loads and the control devices are connected. The user interface is realized by a display and four buttons that allow to view and, if necessary, modify all the operating parameters of the unit. It's available, as an accessory, a remote control that reports all the functionalities of the user interface placed on the unit.

The main functions available are :

- water temperature management (through set point adjustment)
- adaptive function
- climatic control in heating and in cooling mode (automatic set point adjustment according to outdoor air temperature)
- dynamic defrost cycle management according to outdoor air temperature
- alarm memory management and diagnostic
- fans management by means of continuous rotational speed control

- pump management
- integrative electrical heaters management in heating mode (2 step logic)
- compressor and pump operating hours recording
- serial communication through Modbus protocol
- remote stand by
- remote cooling-heating
- general alarm digital output



## DIMENSIONS AND MINIMUM OPERATING AREA

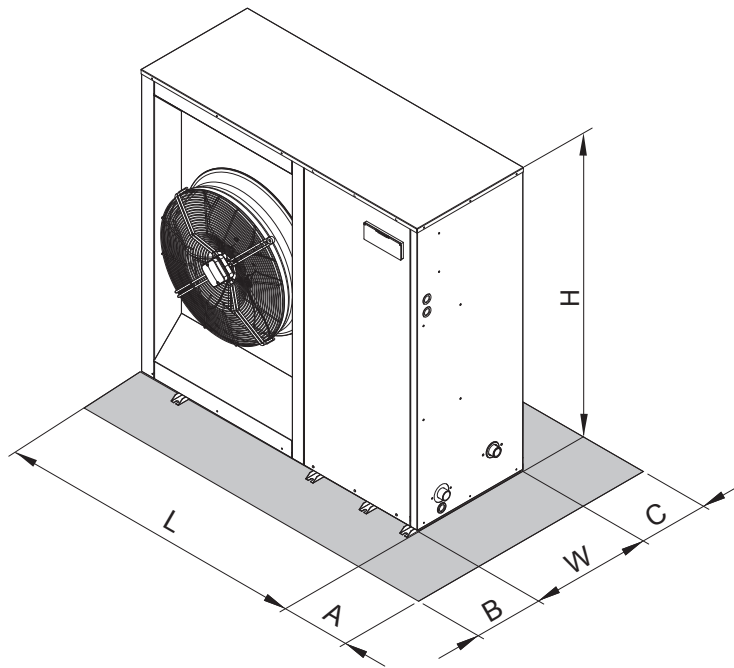

	19.1	22.1	26.1	30.1	35.1	40.1	
L		1494			1704		mm
W		576			576		mm
H		1453			1453		mm
A		400			400		mm
B		600			600		mm
C		200			200		mm
Maximum weight operation (VA Tank version)	349	352	371	385	410	412	kg

# > RMA HE

AIR-WATER CHILLERS AND HEAT PUMPS  
FOR OUTDOOR INSTALLATION



## Available range

### Unit type

IR	Chiller
IP	Heat pump (reversible on the refrigerant side)
BR	Chiller Brine
BP	Heat pump Brine (reversible on the refrigerant side)

### Versions

VB	Base Version
VP	Pump version
VA	Tank version

### Acoustic setting up

AB	Base setting up
AS	Low noise setting up

## Unit description

This series of air-water chillers and heat pumps satisfies the cooling and heating requirements of residential plants of small and medium size.

All the units are suitable for outdoor installation and can be applied to fan coil plants, radiant floor plants and high efficiency radiators plants.

The refrigerant circuit, contained in a compartment protected from the air flow to simplify the maintenance operations, is equipped with scroll compressor mounted

on damper supports, brazed plate heat exchanger, thermostatic expansion valve, reverse cycle valve, axial fans with safety protection grilles, finned coil made of copper pipes and aluminium louvered fins. The circuit is protected by high and low pressure switches and differential pressure switch on the plate heat exchanger.

The plate heat exchanger and all the hydraulic pipes are thermally insulated in order to avoid condensate generation and to reduce thermal losses.

All the units can be equipped with variable speed fans control that allows the units to operate with low outdoor temperatures in cooling and high outdoor temperature in heating and permits to reduce noise emissions in such operating conditions.

The low noise acoustic setting up (AS) is obtained, starting from the base setting up (AB), reducing the rotational speed of the fans and mounting sound jackets on the compressors.

All the units are supplied with an outdoor temperature sensor, already installed on the unit, in order to realize the climatic control.

All the units are provided with a phase presence and correct sequence controller device.

All the units are accurately built and individually tested in the factory. Only electric and hydraulic connections are required for installation.

## Options

### Storing and pumping module

- not present (VB - base version)
- standard, high head or modulating pump (VP - pump version)
- tank and standard, high head or modulating pump (VA - tank version)

### Integrative electrical heaters

- not present
- standard in the tank

### Compressor starting

- standard (contactors)
- soft starter

### Fans control

- on-off control
- modulating control (condensation / evaporation control)

### Electrical loads protection

- fuses
- thermal magnetic circuit breakers

### Compressor power factor correction

## Accessories

Rubber vibration dampers

Coil protection grille

Tank antifreeze electrical heater

Remote control

Modbus serial interface on RS485

Programmer clock

Phase sequence and voltage controller

**NET NOMINAL performances - Standard plants - EUROVENT certified data**

IR	Base setting up (AB)	19.1	22.1	26.1	30.1	35.1	40.1	
A35W7	Cooling capacity	20,1	22,3	26,1	31,5	36,6	41,3	kW
	Power input	6,51	7,15	8,29	10,3	11,9	13,5	kW
	EER	3,09	3,12	3,15	3,06	3,08	3,06	W/W
	ESEER	3,44	3,48	3,51	3,44	3,45	3,45	W/W
	Water flow rate	0,963	1,07	1,25	1,51	1,75	1,98	l/s
	Pressure drops	26	32	26	37	32	41	kPa
	IR	Low noise setting up (AS)	19.1	22.1	26.1	30.1	35.1	40.1
A35W7	Cooling capacity	19,3	21,4	25,1	30,3	35,2	39,8	kW
	Power input	7,02	7,71	8,94	11,1	12,8	14,4	kW
	EER	2,75	2,78	2,81	2,73	2,75	2,76	W/W
	ESEER	3,06	3,10	3,12	3,07	3,08	3,09	W/W
	Water flow rate	0,925	1,02	1,20	1,45	1,69	1,91	l/s
	Pressure drops	24	29	24	35	30	38	kPa
	IP	Base setting up (AB)	19.1	22.1	26.1	30.1	35.1	40.1
A35W7	Cooling capacity	19,7	21,9	25,6	30,9	35,9	40,5	kW
	Power input	6,45	7,08	8,20	10,2	11,8	13,4	kW
	EER	3,05	3,09	3,12	3,03	3,04	3,02	W/W
	ESEER	3,40	3,46	3,47	3,42	3,40	3,40	W/W
	Water flow rate	0,944	1,05	1,23	1,48	1,72	1,94	l/s
	Pressure drops	25	31	25	36	31	39	kPa
A7W45	Heating capacity	21,2	23,5	27,4	33,3	38,6	43,8	kW
	Power input	6,21	6,82	7,89	9,79	11,3	12,9	kW
	COP	3,41	3,45	3,47	3,40	3,42	3,40	W/W
	Water flow rate	1,00	1,11	1,29	1,57	1,82	2,06	l/s
	Pressure drops	28	34	28	40	34	43	kPa
IP	Low noise setting up (AS)	19.1	22.1	26.1	30.1	35.1	40.1	
A35W7	Cooling capacity	18,9	21,0	24,6	29,7	34,5	39,0	kW
	Power input	6,95	7,63	8,84	11,0	12,7	14,3	kW
	EER	2,72	2,75	2,78	2,70	2,72	2,73	W/W
	ESEER	3,03	3,07	3,09	3,04	3,05	3,05	W/W
	Water flow rate	0,906	1,01	1,18	1,43	1,65	1,87	l/s
	Pressure drops	23	28	23	34	29	36	kPa
A7W45	Heating capacity	20,1	22,3	26,1	31,7	36,7	41,7	kW
	Power input	5,95	6,54	7,56	9,38	10,9	12,4	kW
	COP	3,38	3,41	3,45	3,38	3,37	3,36	W/W
	Water flow rate	1,25	1,39	1,63	1,97	2,28	2,58	l/s
	Pressure drops	25	31	25	36	31	40	kPa

**NET NOMINAL performances - Radiant plants**

IR	Base setting up (AB)	19.1	22.1	26.1	30.1	35.1	40.1	
A35W18	Cooling capacity	26,1	28,9	33,9	40,8	47,4	53,5	kW
	Power input	6,67	7,35	8,49	10,6	12,2	13,9	kW
	EER	3,91	3,93	3,99	3,85	3,89	3,85	W/W
	Water flow rate	1,25	1,39	1,63	1,97	2,28	2,58	l/s
	Pressure drops	43	52	43	62	53	67	kPa
IP	Base setting up (AB)	19.1	22.1	26.1	30.1	35.1	40.1	
A35W18	Cooling capacity	25,5	28,4	33,2	40,0	46,5	52,5	kW
	Power input	6,60	7,27	8,40	10,5	12,1	13,7	kW
	EER	3,86	3,91	3,95	3,81	3,84	3,83	W/W
	Water flow rate	1,23	1,36	1,59	1,93	2,24	2,53	l/s
	Pressure drops	41	50	41	59	51	64	kPa
A7W35	Heating capacity	21,6	24,0	28,0	34,0	39,4	44,7	kW
	Power input	5,24	5,76	6,66	8,28	9,57	10,9	kW
	COP	4,12	4,17	4,20	4,11	4,12	4,10	W/W
	Water flow rate	1,02	1,14	1,33	1,61	1,87	2,11	l/s
	Pressure drops	29	36	29	42	36	46	kPa

Data declared according to EN 14511. The values are referred to units without options and accessories.  
**EER** (Energy Efficiency Ratio) = ratio of the total cooling capacity to the effective power input of the unit  
**COP** (Coefficient Of Performance) = ratio of the total heating capacity to the effective power input of the unit

**ESEER** (European Seasonal Energy Efficiency Ratio) = Unit in **A CLASS**.  
**A35W7** = source : air in 35°C d.b. / plant : water in 12°C out 7°C  
**A35W18** = source : air in 35°C d.b. / plant : water in 23°C out 18°C  
**A7W45** = source : air in 7°C d.b. 6°C w.b. / plant : water in 40°C out 45°C  
**A7W35** = source : air in 7°C d.b. 6°C w.b. / plant : water in 30°C out 35°C



### Acoustic performances

Base setting up (AB)	19.1	22.1	26.1	30.1	35.1	40.1	
Sound power level <sup>(E)</sup>	77	77	78	81	82	82	dB(A)
Sound pressure level at 1 meter	61	62	62	65	66	66	dB(A)
Sound pressure level at 5 meters	51	51	52	55	55	56	dB(A)
Sound pressure level at 10 meters	46	46	47	50	50	50	dB(A)
Low noise setting up (AS)	19.1	22.1	26.1	30.1	35.1	40.1	
Sound power level <sup>(E)</sup>	74	74	75	78	79	79	dB(A)
Sound pressure level at 1 meter	58	59	59	62	63	63	dB(A)
Sound pressure level at 5 meters	48	48	49	52	53	53	dB(A)
Sound pressure level at 10 meters	43	43	44	47	48	48	dB(A)

(E): EUROVENT certified data

The acoustic performances are referred to units operating in cooling mode at nominal conditions A35W7.

Unit placed in free field on reflecting surface (directional factor equal to 2).

The sound power level is measured according to ISO 9614 standard.

The sound pressure level is calculated according to ISO 3744 and is referred to a distance of 1/5/10 metres from the external surface of the unit.

### Technical data

Unità	19.1	22.1	26.1	30.1	35.1	40.1	
Power supply	400 - 3+N - 50						V-ph-Hz
Compressor type	scroll						-
N° compressors / N° refrigerant circuits	1 / 1						n°
Plant side heat exchanger type	stainless steel brazed plates						-
Source side heat exchanger type	finned coil						-
Fans type	axial						-
N° fans	1						n°
Tank volume	85						l
Hydraulic fittings	1"1/4 VICTAULIC						-

### Electrical data

Standard unit	19.1	22.1	26.1	30.1	35.1	40.1	
<b>FLA</b> - Full load current at maximum tolerated conditions	18,8	20,8	22,9	25,9	29,9	34,0	A
<b>FLI</b> - Full load power input at maximum tolerated conditions	10,8	12,1	13,4	15,8	18,4	21,0	kW
<b>MIC</b> - Maximum instantaneous current of the unit	98	114	121	129	144	178	A
<b>MIC SS</b> - Maximum instantaneous current of the unit with soft starter options	55	64	68	73	82	102	A
Unit with high head modulating pump	19.1	22.1	26.1	30.1	35.1	40.1	
<b>FLA</b> - Full load current at maximum tolerated conditions	24,9	26,9	29,0	32,0	38,1	42,2	A
<b>FLI</b> - Full load power input at maximum tolerated conditions	12,0	13,3	16,6	17,0	20,0	26,1	kW
<b>MIC</b> - Maximum instantaneous current of the unit	104,1	120,1	127,1	135,1	152,2	186,2	A
<b>MIC SS</b> - Maximum instantaneous current of the unit with soft starter options	61,1	70,1	74,1	79,1	90,2	110,2	A

### Operating range

Temperatura	Unit type	Cooling		Heating		
		min	max	min	max	
Outdoor air inlet temperature	IR, BR, IP, BP	-10*	48	-15	42	(°C)
Water outlet temperature	IR, IP	5	25	30	55	(°C)
Water outlet temperature	BR, BP	-12	25	30	55	(°C)

\* with fans modulating control option (condensation / evaporation control)

## CONTROL SYSTEM

The unit is managed by a microprocessor controller to which, through a wiring board, all the electrical loads and the control devices are connected. The user interface is realized by a display and four buttons that allow to view and, if necessary, modify all the operating parameters of the unit. It's available, as an accessory, a remote control that reports all the functionalities of the user interface placed on the unit.

The main functions available are :

- water temperature management (through set point adjustment)
- adaptive function
- climatic control in heating and in cooling mode (automatic set point adjustment according to outdoor air temperature)
- dynamic defrost cycle management according to outdoor air temperature
- alarm memory management and diagnostic
- fans management by means of continuous rotational speed control

- pump management
- integrative electrical heaters management in heating mode (2 step logic)
- compressor and pump operating hours recording
- serial communication through Modbus protocol
- remote stand by
- remote cooling-heating
- general alarm digital output



## DIMENSIONS AND MINIMUM OPERATING AREA

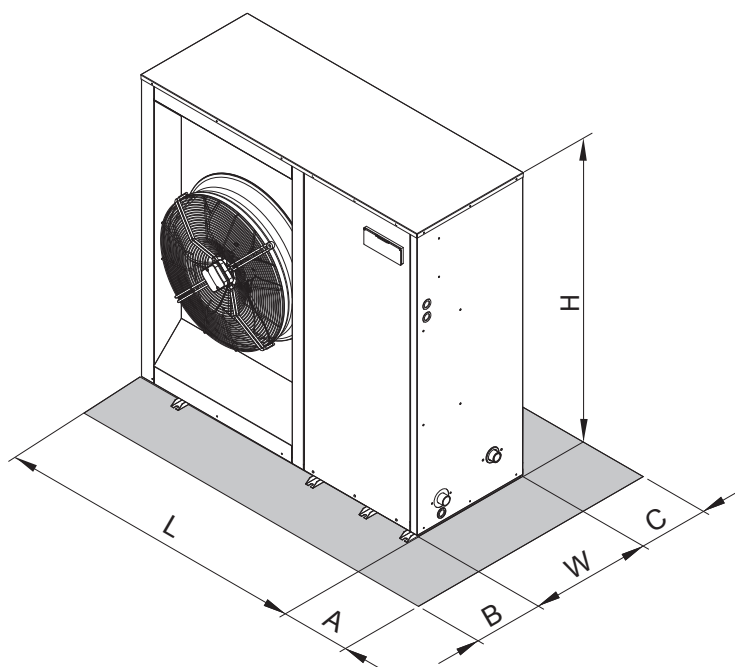

	19.1	22.1	26.1	30.1	35.1	40.1	
L		1494			1704		mm
W		576			576		mm
H		1453			1453		mm
A		400			400		mm
B		600			600		mm
C		200			200		mm
Maximum weight operation (VA Tank version)	364	367	391	412	438	440	kg

# > RGA

## AIR-WATER CHILLERS AND HEAT PUMPS FOR OUTDOOR INSTALLATION



### Available range

#### Unit type

IR	Chiller
IP	Heat pump (reversible on the refrigerant side)
BR	Chiller Brine
BP	Heat pump Brine (reversible on the refrigerant side)

#### Version

VB	Base version
VD	Desuperheater version
VR	Total recovery version

#### Acoustic setting up

AB	Base setting up
AS	Low noise setting up
AX	eXtra low noise setting up

#### Source temperature level

M	Medium temperature level
A	High temperature level

### Unit description

This series of air-water chillers and heat pumps satisfies the cooling and heating requirements of residential plants of medium size.

All the units are suitable for outdoor installation and can be applied to fan coil plants, radiant floor plants and high efficiency radiators plants.

The refrigerant circuit, contained in a compartment protected from the air flow to simplify the maintenance operations, is equipped with scroll compressors mounted on damper supports, brazed plate heat exchanger, thermostatic expansion valve (standard for IR) or electronic expansion

valve (standard for IP / option for IR), reverse cycle valve, dehydrator filter, axial fans with safety protection grilles, finned coil made of copper pipes and aluminium louvered fins with subcooling section. The circuit is protected by a safety gas valve, high and low pressure switches and differential pressure switch on the plate heat exchanger. The plate heat exchanger and all the hydraulic pipes are thermally insulated in order to avoid condensate generation and to reduce thermal losses.

All the units can be equipped with variable speed fans control that allows the units to operate with low outdoor temperatures in cooling and high outdoor temperature in heating and permits to reduce noise emissions in such operating conditions.

The low noise acoustic setting up (AS) is obtained, starting from the base setting up (AB), reducing the rotational speed of the fans and mounting sound jackets on the compressors and the technical compartment is clad with soundproofing material of suitable thickness.

The eXtra low noise acoustic setting up (AX) is obtained, starting from the low noise setting up (AS), further reducing the rotational speed of the fans and using finned coil with bigger surface.

All the units are supplied with a management and control electrical panel containing general switch, phase presence and correct sequence controller, microprocessor controller with display and all the other electrical components with IP54 minimum protection degree.

All the units are accurately built and individually tested in the factory. Only electric and hydraulic connections are required for installation.

### Options

Storing and pumping module available in the configurations :

- Storage tank arranged as buffer on the flow or as primary-secondary buffer
- 1 or 2 pumps
- standard or high head pump
- modulating pump

#### Expansion valve

- thermostatic
- electronic (standard for IP)

#### Compressor starting

- standard (contactors)
- soft starter

#### Fans control

- on-off control
- modulating control (condensation / evaporation control)

#### Compressor power factor correction

#### Electrical load protection

- fuses
- thermal magnetic circuit breakers

#### Coil condensate tray

### Accessories

Rubber vibration dampers

Spring vibration dampers

Coil protection grilles

Tank antifreeze electrical heater

Remote control

Modbus serial interface on RS485

Programmer clock

Phase sequence and voltage controller

Low temperature kit (standard for IP)

High and low pressure gauges

High temperature thermostat

Coil shut off valves

Outdoor air sensor

Water flow switch

Victaulic hydraulic fittings



**NET NOMINAL performances - Standard plants - EUROVENT certified data**

IR	Base setting up (AB)	40.2	50.2	60.2	70.2	80.2	90.2	100.2	115.2	130.2	145.2	160.2	180.2	200.2	
A35W7	Cooling capacity	45,0	53,0	58,1	68,2	78,1	90,3	101	111	125	142	157	179	198	kW
	Power input	15,7	18,8	20,8	24,1	28,0	32,5	35,9	39,9	45,1	51,5	57,1	64,6	71,6	kW
	EER	2,87	2,82	2,79	2,83	2,79	2,78	2,81	2,78	2,77	2,76	2,75	2,77	2,77	W/W
	ESEER	3,93	3,90	3,85	3,91	3,84	3,93	3,86	3,93	3,82	3,89	3,77	3,80	3,82	W/W
	Water flow rate	2,16	2,56	2,80	3,29	3,76	4,35	4,87	5,35	6,02	6,83	7,55	8,60	9,56	l/s
	Pressure drops	40	56	55	51	50	48	46	44	48	47	48	48	50	kPa
IR	Low noise setting up (AS)	40.2	50.2	60.2	70.2	80.2	90.2	100.2	115.2	130.2	145.2	160.2	180.2	200.2	
A35W7	Cooling capacity	43,6	51,5	56,3	66,2	75,7	87,6	97,8	108	121	138	152	174	193	kW
	Power input	16,3	19,4	21,6	24,9	29,2	33,7	37,3	41,4	46,8	53,4	59,2	67,0	74,3	kW
	EER	2,67	2,65	2,61	2,66	2,59	2,60	2,62	2,61	2,59	2,58	2,57	2,60	2,60	W/W
	ESEER	3,81	3,79	3,74	3,80	3,70	3,81	3,73	3,83	3,69	3,79	3,66	3,69	3,70	W/W
	Water flow rate	2,10	2,48	2,71	3,19	3,65	4,21	4,71	5,21	5,83	6,64	7,31	8,36	9,27	l/s
	Pressure drops	38	53	52	48	47	45	43	42	45	44	45	45	47	kPa
IR	eXtra low noise setting up (AX)	40.2	50.2	60.2	70.2	80.2	90.2	100.2	115.2	130.2	145.2	160.2	180.2	200.2	
A35W7	Cooling capacity	42,7	50,3	55,1	64,7	74,0	85,6	95,6	105	118	134	149	169	188	kW
	Power input	16,3	19,8	22,1	25,4	29,9	32,8	38,3	42,6	48,1	54,3	60,3	68,8	76,2	kW
	EER	2,62	2,54	2,49	2,55	2,47	2,61	2,50	2,46	2,45	2,47	2,47	2,46	2,47	W/W
	ESEER	3,96	3,88	3,80	3,89	3,76	4,09	3,79	3,86	3,74	3,86	3,76	3,73	3,75	W/W
	Water flow rate	2,05	2,42	2,65	3,12	3,56	4,12	4,60	5,06	5,69	6,45	7,17	8,12	9,03	l/s
	Pressure drops	36	50	49	46	45	43	41	39	43	42	43	43	45	kPa
IP	Base setting up (AB)	40.2	50.2	60.2	70.2	80.2	90.2	100.2	115.2	130.2	145.2	160.2	180.2	200.2	
A35W7	Cooling capacity	43,5	52,4	57,0	66,7	73,6	88,5	98	109	121	137	153	177	196	kW
	Power input	15,5	19,0	20,7	24,1	27,0	32,3	35,7	39,8	44,5	50,3	56,3	63,5	71,2	kW
	EER	2,81	2,76	2,75	2,77	2,73	2,74	2,75	2,74	2,72	2,72	2,72	2,79	2,75	W/W
	ESEER	3,84	3,82	3,80	3,80	3,73	3,87	3,78	3,87	3,73	3,84	3,72	3,82	3,79	W/W
	Water flow rate	2,09	2,53	2,75	3,21	3,54	4,26	4,73	5,26	5,83	6,59	7,36	8,50	9,46	l/s
	Pressure drops	37	55	53	49	44	46	43	43	45	44	46	47	49	kPa
A7W45	Heating capacity	48,1	58,1	63,2	74,5	83,0	99,6	110	125	136	154	173	197	216	kW
	Power input	15,6	19,1	20,9	24,4	27,6	33,5	35,9	41,1	44,9	51,8	56,9	65,1	71,7	kW
	COP	3,08	3,04	3,02	3,05	3,01	2,97	3,06	3,04	3,03	2,97	3,04	3,03	3,01	W/W
	Water flow rate	2,28	2,75	2,99	3,53	3,93	4,72	5,21	5,92	6,45	7,31	8,17	9,32	10,2	l/s
	Pressure drops	45	65	63	59	55	57	53	54	55	54	56	56	57	kPa
	IP	Low noise setting up (AS)	40.2	50.2	60.2	70.2	80.2	90.2	100.2	115.2	130.2	145.2	160.2	180.2	200.2
A35W7	Cooling capacity	41,8	50,4	54,8	64,0	70,6	85,0	94,4	105	116	131	147	170	189	kW
	Power input	16,0	20,0	21,8	25,5	28,6	34,1	37,7	42,0	47,0	53,1	59,5	67,1	75,3	kW
	EER	2,61	2,52	2,51	2,51	2,47	2,49	2,50	2,50	2,47	2,47	2,47	2,53	2,51	W/W
	ESEER	3,69	3,60	3,58	3,58	3,52	3,65	3,55	3,67	3,52	3,60	3,52	3,60	3,57	W/W
	Water flow rate	2,01	2,43	2,64	3,08	3,40	4,09	4,54	5,06	5,59	6,31	7,07	8,17	9,08	l/s
	Pressure drops	35	50	49	45	41	42	40	39	41	40	42	43	45	kPa
A7W45	Heating capacity	46,9	56,5	61,7	72,5	80,9	97,0	107	122	133	150	168	192	211	kW
	Power input	14,9	18,2	20,0	23,2	26,4	31,9	34,2	39,2	42,8	49,4	54,3	62,1	68,5	kW
	COP	3,15	3,10	3,09	3,13	3,06	3,04	3,13	3,11	3,11	3,04	3,09	3,09	3,08	W/W
	Water flow rate	2,23	2,68	2,92	3,44	3,83	4,60	5,06	5,78	6,31	7,12	7,98	9,08	9,99	l/s
	Pressure drops	43	61	60	56	52	54	50	51	53	51	54	54	55	kPa
	IP	eXtra low noise setting up (AX)	40.2	50.2	60.2	70.2	80.2	90.2	100.2	115.2	130.2	145.2	160.2	180.2	200.2
A35W7	Cooling capacity	41,0	49,3	53,7	62,8	69,3	83,3	92,5	102	114	129	144	166	185	kW
	Power input	17,1	21,1	23,0	26,8	30,1	35,9	39,8	44,3	49,5	56,0	62,7	70,8	79,4	kW
	EER	2,40	2,34	2,33	2,34	2,30	2,32	2,32	2,30	2,30	2,30	2,30	2,34	2,33	W/W
	ESEER	3,62	3,56	3,55	3,55	3,49	3,62	3,53	3,60	3,50	3,60	3,49	3,56	3,53	W/W
	Water flow rate	1,97	2,37	2,58	3,02	3,33	4,00	4,45	4,92	5,49	6,21	6,93	7,98	8,89	l/s
	Pressure drops	33	48	47	43	39	41	38	37	40	39	40	41	43	kPa
A7W45	Heating capacity	45,2	54,5	59,4	70,0	78,0	93,5	104	118	128	145	162	184	203	kW
	Power input	14,2	17,3	19,0	22,2	25,1	30,4	32,7	37,3	40,8	47,1	51,7	59,1	65,1	kW
	COP	3,18	3,15	3,13	3,15	3,11	3,08	3,18	3,16	3,14	3,08	3,13	3,11	3,12	W/W
	Water flow rate	2,15	2,58	2,81	3,32	3,70	4,43	4,92	5,59	6,07	6,88	7,69	8,74	9,60	l/s
	Pressure drops	40	57	55	52	48	50	47	48	49	48	50	50	50	kPa

**NET NOMINAL performances - Radiant plants**

IR	Base setting up (AB)	40.2	50.2	60.2	70.2	80.2	90.2	100.2	115.2	130.2	145.2	160.2	180.2	200.2	
A35W18	Cooling capacity	58,3	68,5	75,1	88,2	100,6	116	131	144	162	184	202	231	257	kW
	Power input	17,1	20,8	22,9	26,4	30,8	35,6	39,4	43,6	49,4	56,4	62,5	70,7	78,5	kW
	EER	3,41	3,29	3,28	3,34	3,27	3,26	3,32	3,30	3,28	3,26	3,23	3,27	3,27	W/W
	Water flow rate	2,81	3,33	3,64	4,27	4,87	5,64	6,35	6,98	7,84	8,89	9,8	11,2	12,4	l/s
	Pressure drops	68	95	93	86	84	81	78	75	81	80	81	81	84	kPa
	IP	Base setting up (AB)	40.2	50.2	60.2	70.2	80.2	90.2	100.2	115.2	130.2	145.2	160.2	180.2	200.2
A35W18	Cooling capacity	56,3	67,8	73,7	86,3	95,2	115	127	141	157	177	198	228	254	kW
	Power input	16,9	20,9	22,8	26,4	29,7	35,2	39,0	43,4	48,8	54,9	61,7	69,5	78,1	kW
	EER	3,33	3,24	3,23	3,27	3,21	3,27	3,26	3,25	3,22	3,22	3,21	3,28	3,25	W/W
	Water flow rate	2,72	3,29	3,57	4,18	4,60	5,54	6,16	6,83	7,60	8,55	9,56	11,0	12,3	l/s
	Pressure drops	63	92	89	82	75	78	74	72	77	74	77	79	83	kPa
	A7W35	Heating capacity	51,1	61,7	67,1	79,0	88,0	106	117	132	144	164	183	209	229
Power input		12,9	15,7	17,3	20,1	22,7	27,9	29,8	34,0	37,1	43,0	47,2	54,3	59,6	kW
COP		3,96	3,93	3,88	3,93	3,88	3,80	3,93	3,88	3,88	3,81	3,88	3,85	3,84	W/W
Water flow rate		2,42	2,91	3,17	3,74	4,17	5,02	5,54	6,26	6,83	7,74	8,65	9,89	10,8	l/s
Pressure drops		50	72	70	66	61	64	60	60	62	60	63	63	64	kPa

Data declared according to EN 14511. The values are referred to units without options and accessories.

EER (Energy Efficiency Ratio) = ratio of the total cooling capacity to the effective power input of the unit

COP (Coefficient Of Performance) = ratio of the total heating capacity to the effective power input of the unit

ESEER (European Seasonal Energy Efficiency Ratio)

\_\_\_\_\_ = Unit in A CLASS.

A35W7 = source : air in 35°C d.b. / plant : water in 12°C out 7°C

A35W18 = source : air in 35°C d.b. / plant : water in 23°C out 18°C

A7W45 = source : air in 7°C d.b. 6°C w.b. / plant : water in 40°C out 45°C

A7W35 = source : air in 7°C d.b. 6°C w.b. / plant : water in 30°C out 35°C

**Acoustic performances**

Base setting up (AB)	40.2	50.2	60.2	70.2	80.2	90.2	100.2	115.2	130.2	145.2	160.2	180.2	200.2	
Sound power level <sup>(E)</sup>	82	82	83	84	84	85	85	85	86	87	87	88	88	dB(A)
Sound pressure level at 1 meter	64	64	65	66	66	67	67	67	68	69	69	69	69	dB(A)
Sound pressure level at 5 meters	55	55	56	57	57	58	58	58	59	60	60	61	61	dB(A)
Sound pressure level at 10 meters	50	50	51	52	52	53	53	53	54	55	55	56	56	dB(A)
Low noise setting up (AS)	40.2	50.2	60.2	70.2	80.2	90.2	100.2	115.2	130.2	145.2	160.2	180.2	200.2	
Sound power level <sup>(E)</sup>	79	79	80	81	81	82	82	82	83	84	84	85	85	dB(A)
Sound pressure level at 1 meter	61	61	62	63	63	64	64	64	65	66	66	66	66	dB(A)
Sound pressure level at 5 meters	52	52	53	54	54	55	55	55	56	57	57	58	58	dB(A)
Sound pressure level at 10 meters	47	47	48	49	49	50	50	50	51	52	52	53	53	dB(A)
eXtra low noise setting up (AX)	40.2	50.2	60.2	70.2	80.2	90.2	100.2	115.2	130.2	145.2	160.2	180.2	200.2	
Sound power level <sup>(E)</sup>	77	77	78	79	79	80	80	80	81	82	82	83	83	dB(A)
Sound pressure level at 1 meter	59	59	60	61	61	62	62	62	63	64	64	64	64	dB(A)
Sound pressure level at 5 meters	50	50	51	52	52	53	53	53	54	55	55	56	56	dB(A)
Sound pressure level at 10 meters	45	45	46	47	47	48	48	48	49	50	50	51	51	dB(A)

**(E): EUROVENT** certified data

The acoustic performances are referred to units operating in cooling mode at nominal conditions A35W7.

Unit placed in free field on reflecting surface (directional factor equal to 2).

The sound power level is measured according to ISO 9614 standard.

The sound pressure level is calculated according to ISO 3744 and is referred to a distance of 1/5/10 metres from the external surface of the unit.

**Technical data**

Unit	40.2	50.2	60.2	70.2	80.2	90.2	100.2	115.2	130.2	145.2	160.2	180.2	200.2	
Power supply	400 - 3+N - 50						400 - 3 - 50						V-ph-Hz	
Compressor type	scroll													-
N° compressors / N° refrigerant circuits	2 / 1													n°
Plant side heat exchanger type	stainless steel brazed plates													-
Source side heat exchanger type	finned coil													-
Fans type	axial													-
N° fans	2	3			2			3	4			n°		
Tank volume	200						400			460				l
Hydraulic fittings	2" VICTAULIC						2" 1/2 VICTAULIC						-	

**Electrical data**

Standard unit	40.2	50.2	60.2	70.2	80.2	90.2	100.2	115.2	130.2	145.2	160.2	180.2	200.2	
<b>FLA</b> - Full load current at maximum tolerated conditions	40,2	45,7	53,3	58,7	69,6	75,5	90,0	97,9	106	123	136	159	170	A
<b>FLI</b> - Full load power input at maximum tolerated conditions	21,6	24,4	28,4	31,0	36,2	44,0	55,0	60,5	66,0	75,7	83,3	95,4	103	kW
<b>MIC</b> - Maximum instantaneous current of the unit	134	143	149	173	213	264	259	267	267	348	361	355	391	A
<b>MIC SS</b> - Maximum instantaneous current of the unit with soft starter options	89,3	96,3	101	117	143	174	175	183	183	200	246	248	272	A
Unit with high head modulating pump	40.2	50.2	60.2	70.2	80.2	90.2	100.2	115.2	130.2	145.2	160.2	180.2	200.2	
<b>FLA</b> - Full load current at maximum tolerated conditions	46,3	51,8	59,4	64,8	76,0	81,6	96,1	107	115	132	147	169	180	A
<b>FLI</b> - Full load power input at maximum tolerated conditions	25,1	27,9	31,9	34,5	42,1	47,5	58,5	65,1	70,6	80,3	89,6	102	109	kW
<b>MIC</b> - Maximum instantaneous current of the unit	140	150	155	179	219	270	265	276	276	357	372	365	402	A
<b>MIC SS</b> - Maximum instantaneous current of the unit with soft starter options	95,4	102	107	123	150	180	181	192	192	209	257	258	282	A

**Operative range**

Temperature	Unit type	Cooling		Heating		
		min	max	min	max	
Outdoor air inlet temperature	IR, BR, IP, BP	-10*	50	-10	40*	(°C)
Water outlet temperature	IR, IP	5	25	30	55	(°C)
Water outlet temperature	BR, BP	-12	25	30	55	(°C)
Water outlet temperature (VD)	IR, BR, IP, BP	30	70	30	70	(°C)
Water outlet temperature (VR)	IR, BR	30	55	-	-	(°C)

\* with fans modulating control option (condensation / evaporation control)

## VD and VR versions

These units allow to recover the heating power, otherwise wasted on air, through an additional heat exchanger.

The **Desuperheater Version (VD)** allow the hot water production at temperatures between 30 and 70°C through the partial heat recovery of the condensation heat.

The **Total Recovery Version (VR)** allows the cold water production and, at the same time, the hot water production at temperatures between 30 and 55°C through the total recovery of the condensation heat.

### Desupeheater Version (VD) - NET NOMINAL performances

IR	Base setting up (AB)	40.2	50.2	60.2	70.2	80.2	90.2	100.2	115.2	130.2	145.2	160.2	180.2	200.2	
A35W7 - W45	Cooling capacity	46,8	55,1	60,3	71	81,1	93,8	105	115	130	148	163	185	206	kW
	Total power input	15,3	18,3	20,3	23,4	27,3	31,8	35,1	38,9	44	50,3	55,8	63	69,9	kW
	EER	<b>3,05</b>	<b>3</b>	<b>2,98</b>	<b>3,03</b>	<b>2,97</b>	<b>2,95</b>	<b>2,99</b>	<b>2,96</b>	<b>2,95</b>	<b>2,94</b>	<b>2,92</b>	<b>2,94</b>	<b>2,95</b>	W/W
	HRE	<b>3,93</b>	<b>3,86</b>	<b>3,84</b>	<b>3,88</b>	<b>3,83</b>	<b>3,8</b>	<b>3,86</b>	<b>3,85</b>	<b>3,83</b>	<b>3,81</b>	<b>3,8</b>	<b>3,82</b>	<b>3,83</b>	W/W
	Water flow rate	2,25	2,66	2,91	3,42	3,91	4,52	5,06	5,54	6,26	7,12	7,84	8,93	9,94	l/s
	Water pressure drop	43	60	59	55	54	52	50	47	52	51	52	52	54	kPa
	Heating recovery capacity	13,5	15,7	17,6	20	23,6	27,1	30,4	34,4	38,4	44	49,3	55,4	61,3	kW
	Water flow rate recovery	0,65	0,75	0,84	0,96	1,13	1,29	1,45	1,64	1,83	2,1	2,36	2,65	2,93	l/s
	Water pressure drop recovery	6	9	11	14	19	15	18	11	14	18	22	18	21	kPa
	A35W7 - W45	IP Base setting up (AB)	40.2	50.2	60.2	70.2	80.2	90.2	100.2	115.2	130.2	145.2	160.2	180.2	200.2
Cooling capacity		45,3	54,5	59,3	69,3	76,5	92,1	102	113	126	143	159	183	204	kW
Total power input		15,1	18,5	20,1	23,5	26,4	31,5	34,9	38,7	43,4	49,1	54,9	62,1	69,5	kW
EER		<b>3</b>	<b>2,94</b>	<b>2,94</b>	<b>2,95</b>	<b>2,9</b>	<b>2,92</b>	<b>2,93</b>	<b>2,92</b>	<b>2,9</b>	<b>2,91</b>	<b>2,89</b>	<b>2,95</b>	<b>2,94</b>	W/W
HRE		<b>3,86</b>	<b>3,76</b>	<b>3,79</b>	<b>3,78</b>	<b>3,77</b>	<b>3,75</b>	<b>3,77</b>	<b>3,78</b>	<b>3,76</b>	<b>3,77</b>	<b>3,75</b>	<b>3,8</b>	<b>3,77</b>	W/W
Water flow rate		2,18	2,63	2,86	3,34	3,68	4,43	4,92	5,45	6,07	6,88	7,64	8,84	9,84	l/s
Water pressure drop		41	59	57	53	48	50	47	46	49	48	49	51	53	kPa
Heating recovery capacity		13	15,2	17	19,4	22,9	26,2	29,2	33,2	37,1	42,4	47,5	52,4	58,1	kW
Water flow rate recovery		0,62	0,73	0,81	0,93	1,09	1,25	1,4	1,59	1,77	2,03	2,27	2,5	2,78	l/s
Water pressure drop recovery		6	8	10	13	18	14	17	10	13	17	21	16	19	kPa

### Total Recovery Version (VR) - NET NOMINAL performances

IR	Base setting up (AB)	40.2	50.2	60.2	70.2	80.2	90.2	100.2	115.2	130.2	145.2	160.2	180.2	200.2	
A35W7 - W45	Cooling capacity	46,8	55,1	60,3	71	81,1	93,8	105	115	130	148	163	185	206	kW
	Total power input	13,9	16,9	18,4	21,4	25,3	27,9	31,1	35	40	44,4	49,9	55,3	62,1	kW
	EER	<b>3,36</b>	<b>3,25</b>	<b>3,28</b>	<b>3,31</b>	<b>3,2</b>	<b>3,36</b>	<b>3,38</b>	<b>3,29</b>	<b>3,25</b>	<b>3,33</b>	<b>3,26</b>	<b>3,35</b>	<b>3,32</b>	W/W
	HRE	<b>7,67</b>	<b>7,46</b>	<b>7,52</b>	<b>7,58</b>	<b>7,35</b>	<b>7,67</b>	<b>7,71</b>	<b>7,52</b>	<b>7,45</b>	<b>7,61</b>	<b>7,47</b>	<b>7,65</b>	<b>7,59</b>	W/W
	Water flow rate	2,25	2,66	2,91	3,42	3,91	4,52	5,06	5,54	6,26	7,12	7,84	8,93	9,94	l/s
	Water pressure drop	43	60	59	55	54	52	50	47	52	51	52	52	54	kPa
	Heating recovery capacity	60	71,2	77,8	91,4	105	120	135	148	168	190	210	238	265	kW
	Water flow rate recovery	2,87	3,4	3,72	4,37	5,02	5,73	6,45	7,07	8,03	9,08	10	11,4	12,7	l/s
	Water pressure drop recovery	35	49	41	45	50	48	52	47	52	51	52	55	55	kPa

Data declared according to EN 14511. The values are referred to units without options and accessories.

**EER** (Energy Efficiency Ratio) = ratio of the total cooling capacity to the effective power input of the unit

**HRE** (Heat Recovery Efficiency) = ratio of the total capacity of the system (heating plus cooling capacity) to the effective power input

**A35W7 - W45** = source : air in 35°C d.b. / plant : water in 12°C out 7°C / Recovery : water in 40°C out 45°C

## CONTROL SYSTEM

The units are equipped with a controller designed to ensure energy saving and unit efficiency. Available functions :

- Adaptive function
- Dynamic defrost
- Sound management
- Climatic control in heating and in cooling mode
- Economy function
- Demand limit
- Integrative heating
- Remote stand by
- Remote cooling-heating



## DIMENSIONS - MINIMUM OPERATING AREA - WEIGHT

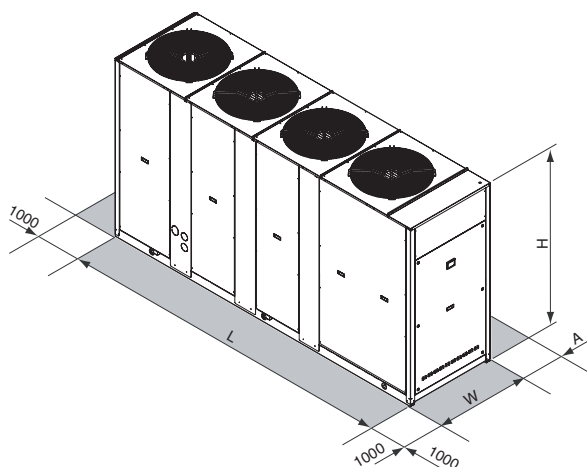

	40.2	50.2	60.2	70.2	80.2	90.2	100.2	115.2	130.2	145.2	160.2	180.2	200.2	
L			2501				3343			3343			4097	mm
W			954				1104			1104			1104	mm
H			1930				1793			2193			2193	mm
A			1600				2000			2000			2000	mm
Operating maximum weight*	1027	1031	1053	1088	1107	1587	1668	1749	1833	1891	1935	2260	2296	kg



# > RGA HE

AIR-WATER CHILLERS AND HEAT PUMPS  
FOR OUTDOOR INSTALLATION



## Available range

### Unit type

IR	Chiller
IP	Heat pump (reversible on the refrigerant side)
BR	Chiller Brine
BP	Heat pump Brine (reversible on the refrigerant side)

### Version

VB	Base version
VD	Desuperheater version
VR	Total recovery version

### Acoustic setting up

AB	Base setting up
AS	Low noise setting up
AX	eXtra low noise setting up

### Source temperature level

M	Medium temperature level
A	High temperature level

## Unit description

This series of air-water chillers and heat pumps satisfies the cooling and heating requirements of residential plants of medium size.

All the units are suitable for outdoor installation and can be applied to fan coil plants, radiant floor plants and high efficiency radiators plants.

The refrigerant circuit, contained in a compartment protected from the air flow to simplify the maintenance operations, is equipped with scroll compressors mounted on damper supports, brazed plate heat exchanger, thermostatic expansion valve (standard for IR) or electronic expansion

valve (standard for IP / option for IR), reverse cycle valve, dehydrator filter, axial fans with safety protection grilles, finned coil made of copper pipes and aluminium louvered fins with subcooling section. The circuit is protected by a safety gas valve, high and low pressure switches and differential pressure switch on the plate heat exchanger. The plate heat exchanger and all the hydraulic pipes are thermally insulated in order to avoid condensate generation and to reduce thermal losses.

All the units can be equipped with variable speed fans control that allows the units to operate with low outdoor temperatures in cooling and high outdoor temperature in heating and permits to reduce noise emissions in such operating conditions.

The low noise acoustic setting up (AS) is obtained, starting from the base setting up (AB), reducing the rotational speed of the fans and mounting sound jackets on the compressors and the technical compartment is clad with soundproofing material of suitable thickness.

The eXtra low noise acoustic setting up (AX) is obtained, starting from the low noise setting up (AS), further reducing the rotational speed of the fans and using finned coil with bigger surface.

All the units are supplied with a management and control electrical panel containing general switch, phase presence and correct sequence controller, microprocessor controller with display and all the other electrical components with IP54 minimum protection degree.

All the units are accurately built and individually tested in the factory. Only electric and hydraulic connections are required for installation.

## Options

Storing and pumping module available in the configurations :

- Storage tank arranged as buffer on the flow or as primary-secondary buffer
- 1 or 2 pumps
- standard or high head pump
- modulating pump

### Expansion valve

- thermostatic
- electronic (standard for IP)

### Compressor starting

- standard (contactors)
- soft starter

### Fans control

- on-off control
- modulating control (condensation / evaporation control)

### Compressor power factor correction

### Electrical load protection

- fuses
- thermal magnetic circuit breakers

### Coil condensate tray

## Accessories

Rubber vibration dampers

Spring vibration dampers

Coil protection grilles

Tank antifreeze electrical heater

Remote control

Modbus serial interface on RS485

Programmer clock

Phase sequence and voltage controller

Low temperature kit (standard for IP)

High and low pressure gauges

High temperature thermostat

Coil shut off valves

Outdoor air sensor

Water flow switch

Victaulic hydraulic fittings

**NET NOMINAL performances - Standard plants - EUROVENT certified data**

IR	Base setting up (AB)	40.2	50.2	60.2	70.2	80.2	90.2	100.2	115.2	130.2	145.2	160.2	180.2	
A35W7	Cooling capacity	47,2	55,9	63,1	70,5	83,4	94,9	106	120	133	153	173	197	kW
	Power input	14,9	17,2	19,8	22,1	27,2	31,2	34,6	38,6	42,7	50,0	55,5	64,6	kW
	EER	3,17	3,25	3,19	3,19	3,07	3,04	3,06	3,11	3,11	3,06	3,12	3,05	W/W
	ESEER	4,31	4,44	4,34	4,39	4,17	4,27	4,20	4,37	4,26	4,31	4,27	4,16	W/W
	Water flow rate	2,26	2,69	3,03	3,39	4,00	4,56	5,11	5,78	6,40	7,36	8,31	9,46	l/s
	Pressure drops	24	34	33	41	31	32	34	33	35	35	38	39	kPa
IR	Low noise setting up (AS)	40.2	50.2	60.2	70.2	80.2	90.2	100.2	115.2	130.2	145.2	160.2	180.2	
A35W7	Cooling capacity	45,0	53,3	60,1	67,3	79,5	90,5	101	114	127	146	165	188	kW
	Power input	15,5	17,9	20,6	22,9	27,7	31,9	35,6	39,8	44,3	51,3	57,2	66,3	kW
	EER	2,90	2,98	2,92	2,94	2,87	2,84	2,84	2,86	2,87	2,85	2,88	2,84	W/W
	ESEER	4,10	4,23	4,13	4,17	4,06	4,12	4,03	4,17	4,08	4,15	4,09	4,02	W/W
	Water flow rate	2,16	2,56	2,89	3,23	3,82	4,34	4,87	5,49	6,12	7,02	7,93	9,03	l/s
	Pressure drops	22	31	30	37	28	29	31	30	32	32	35	36	kPa
IR	eXtra low noise setting up (AX)	40.2	50.2	60.2	70.2	80.2	90.2	100.2	115.2	130.2	145.2	160.2	180.2	
A35W7	Cooling capacity	44,3	52,4	59,1	66,1	78,2	89,0	100	112	125	143	162	184	kW
	Power input	15,6	18,1	20,8	23,2	27,9	32,3	36,0	40,4	44,9	51,8	57,8	66,9	kW
	EER	2,84	2,90	2,84	2,85	2,80	2,76	2,76	2,77	2,78	2,76	2,80	2,75	W/W
	ESEER	4,26	4,36	4,31	4,33	4,22	4,28	4,18	4,32	4,22	4,31	4,26	4,17	W/W
	Water flow rate	2,12	2,51	2,84	3,18	3,75	4,27	4,78	5,40	6,02	6,88	7,79	8,84	l/s
	Pressure drops	21	30	29	36	27	28	30	29	31	31	33	34	kPa
IP	Base setting up (AB)	40.2	50.2	60.2	70.2	80.2	90.2	100.2	115.2	130.2	145.2	160.2	180.2	
A35W7	Cooling capacity	45,3	53,6	60,7	67,8	81,3	92,4	103	115	128	147	166	191	kW
	Power input	14,6	17,1	19,4	21,7	26,7	30,2	33,8	37,8	41,8	48,5	54,3	62,8	kW
	EER	3,10	3,13	3,13	3,12	3,04	3,06	3,05	3,04	3,06	3,03	3,06	3,04	W/W
	ESEER	4,22	4,29	4,27	4,28	4,15	4,28	4,16	4,28	4,19	4,26	4,17	4,15	W/W
	Water flow rate	2,17	2,58	2,91	3,26	3,90	4,43	4,97	5,54	6,16	7,07	7,98	9,17	l/s
	Pressure drops	22	31	30	38	29	30	32	30	32	32	35	37	kPa
A7W45	Heating capacity	49,4	58,3	66,0	74,1	88,4	100	113	126	141	161	181	207	kW
	Power input	15,5	18,1	20,8	23,4	27,9	31,6	35,5	39,7	44,3	51,0	57,1	65,6	kW
	COP	3,19	3,22	3,17	3,17	3,17	3,16	3,18	3,17	3,18	3,16	3,17	3,16	W/W
	Water flow rate	2,35	2,77	3,13	3,52	4,20	4,77	5,35	5,97	6,69	7,64	8,60	9,84	l/s
	Pressure drops	26	36	35	44	34	35	37	35	38	38	41	42	kPa
	IP	Low noise setting up (AS)	40.2	50.2	60.2	70.2	80.2	90.2	100.2	115.2	130.2	145.2	160.2	180.2
A35W7	Cooling capacity	43,2	51,1	57,8	64,6	77,5	88,0	98,6	110	122	140	158	182	kW
	Power input	15,1	17,7	20,1	22,6	27,1	31,0	34,8	39,0	43,3	49,8	56,1	64,4	kW
	EER	2,86	2,89	2,88	2,86	2,86	2,84	2,83	2,82	2,82	2,81	2,82	2,83	W/W
	ESEER	4,00	4,07	4,07	4,06	4,03	4,13	4,01	4,08	4,00	4,10	4,00	4,00	W/W
	Water flow rate	2,07	2,45	2,78	3,11	3,72	4,22	4,73	5,26	5,88	6,74	7,60	8,74	l/s
	Pressure drops	20	28	28	35	27	27	29	27	30	29	32	33	kPa
A7W45	Heating capacity	48,1	56,8	64,2	72,2	86,0	97,7	110	123	137	157	176	202	kW
	Power input	14,9	17,5	20,0	22,7	26,4	30,1	34,0	38,2	42,8	48,8	54,8	62,7	kW
	COP	3,23	3,25	3,21	3,18	3,26	3,25	3,24	3,22	3,20	3,22	3,21	3,22	W/W
	Water flow rate	2,29	2,70	3,05	3,43	4,09	4,64	5,21	5,83	6,50	7,45	8,36	9,60	l/s
	Pressure drops	25	34	33	42	32	33	35	34	36	36	38	40	kPa
	IP	eXtra low noise setting up (AX)	40.2	50.2	60.2	70.2	80.2	90.2	100.2	115.2	130.2	145.2	160.2	180.2
A35W7	Cooling capacity	42,5	50,3	56,9	63,6	76,2	86,5	97,0	109	120	138	155	179	kW
	Power input	15,3	18,0	20,3	22,8	27,4	31,4	35,2	39,6	44,0	50,2	56,7	65,0	kW
	EER	2,78	2,79	2,80	2,79	2,78	2,75	2,76	2,75	2,73	2,75	2,73	2,75	W/W
	ESEER	4,16	4,21	4,22	4,22	4,19	4,28	4,15	4,26	4,15	4,28	4,15	4,17	W/W
	Water flow rate	2,04	2,41	2,73	3,05	3,66	4,15	4,65	5,21	5,78	6,64	7,45	8,60	l/s
	Pressure drops	20	27	27	33	26	27	28	27	29	28	31	32	kPa
A7W45	Heating capacity	47,6	56,1	63,4	71,3	85,0	96,5	109	121	136	155	174	199	kW
	Power input	14,7	17,2	19,6	22,2	25,9	29,5	33,3	37,4	42,0	47,7	53,6	61,3	kW
	COP	3,24	3,26	3,23	3,21	3,28	3,27	3,27	3,24	3,24	3,25	3,25	3,25	W/W
	Water flow rate	2,26	2,67	3,01	3,38	4,04	4,59	5,16	5,73	6,45	7,36	8,27	9,46	l/s
	Pressure drops	24	33	33	41	32	32	35	32	36	35	38	39	kPa

**NET NOMINAL performances - Radiant plants**

IR	Base setting up (AB)	40.2	50.2	60.2	70.2	80.2	90.2	100.2	115.2	130.2	145.2	160.2	180.2	
A35W18	Cooling capacity	61,2	72,4	81,7	91,3	108	123	138	156	172	198	224	254	kW
	Power input	16,2	18,9	21,6	24,2	29,6	34,0	37,7	42,2	46,7	54,5	60,6	70,6	kW
	EER	3,78	3,83	3,78	3,77	3,65	3,62	3,66	3,70	3,68	3,63	3,70	3,60	W/W
	Water flow rate	2,94	3,49	3,94	4,41	5,21	5,92	6,64	7,50	8,31	9,56	10,8	12,3	l/s
	Pressure drops	41	57	56	69	53	54	57	56	59	59	64	66	kPa
IP	Base setting up (AB)	40.2	50.2	60.2	70.2	80.2	90.2	100.2	115.2	130.2	145.2	160.2	180.2	
A35W18	Cooling capacity	58,8	69,5	78,6	87,8	105	120	134	150	167	190	215	248	kW
	Power input	15,9	18,6	21,2	23,8	28,9	32,9	36,9	41,1	45,6	52,8	59,3	68,6	kW
	EER	3,70	3,74	3,71	3,69	3,63	3,65	3,63	3,65	3,66	3,60	3,63	3,62	W/W
	Water flow rate	2,83	3,35	3,79	4,24	5,06	5,78	6,45	7,21	8,03	9,17	10,40	11,9	l/s
	Pressure drops	38	53	52	64	50	51	54	51	55	54	60	62	kPa
A7W35	Heating capacity	52,4	61,9	69,9	78,6	93,8	107	120	134	149	171	192	220	kW
	Power input	12,7	14,9	17,1	19,3	23,2	26,2	29,4	32,7	36,5	42,3	47,2	54,4	kW
	COP	4,13	4,15	4,09	4,07	4,04	4,08	4,08	4,10	4,08	4,04	4,07	4,04	W/W
	Water flow rate	2,49	2,94	3,32	3,73	4,45	5,06	5,69	6,35	7,07	8,12	9,13	10,4	l/s
	Pressure drops	29	41	40	50	38	39	42	40	43	43	46	47	kPa

Data declared according to EN 14511. The values are referred to units without options and accessories.

EER (Energy Efficiency Ratio) = ratio of the total cooling capacity to the effective power input of the unit

COP (Coefficient Of Performance) = ratio of the total heating capacity to the effective power input of the unit

ESEER (European Seasonal Energy Efficiency Ratio) = Unit in A CLASS.

A35W7 = source : air in 35°C d.b. / plant : water in 12°C out 7°C

A35W18 = source : air in 35°C d.b. / plant : water in 23°C out 18°C

A7W45 = source : air in 7°C d.b. 6°C w.b. / plant : water in 40°C out 45°C

A7W35 = source : air in 7°C d.b. 6°C w.b. / plant : water in 30°C out 35°C

### Acoustic performances

Base setting up (AB)	40.2	50.2	60.2	70.2	80.2	90.2	100.2	115.2	130.2	145.2	160.2	180.2	
Sound power level <sup>(E)</sup>	82	82	83	84	85	85	85	85	86	87	87	88	dB(A)
Sound pressure level at 1 meter	64	64	65	66	67	67	67	67	68	69	69	69	dB(A)
Sound pressure level at 5 meters	55	55	56	57	58	58	58	58	59	60	60	61	dB(A)
Sound pressure level at 10 meters	50	50	51	52	53	53	53	53	54	55	55	56	dB(A)
Low noise setting up (AS)	40.2	50.2	60.2	70.2	80.2	90.2	100.2	115.2	130.2	145.2	160.2	180.2	
Sound power level <sup>(E)</sup>	79	79	80	81	82	82	82	82	83	84	84	85	dB(A)
Sound pressure level at 1 meter	61	61	62	63	64	64	64	64	65	66	66	66	dB(A)
Sound pressure level at 5 meters	52	52	53	54	55	55	55	55	56	57	57	58	dB(A)
Sound pressure level at 10 meters	47	47	48	49	50	50	50	50	51	52	52	53	dB(A)
eXtra low noise setting up (AX)	40.2	50.2	60.2	70.2	80.2	90.2	100.2	115.2	130.2	145.2	160.2	180.2	
Sound power level <sup>(E)</sup>	77	77	78	79	80	80	80	80	81	82	82	83	dB(A)
Sound pressure level at 1 meter	59	59	60	61	62	62	62	62	63	64	64	64	dB(A)
Sound pressure level at 5 meters	50	50	51	52	53	53	53	53	54	55	55	56	dB(A)
Sound pressure level at 10 meters	45	45	46	47	48	48	48	48	49	50	50	51	dB(A)

(E): EUROVENT certified data

The acoustic performances are referred to units operating in cooling mode at nominal conditions A35W7.

Unit placed in free field on reflecting surface (directional factor equal to 2).

The sound power level is measured according to ISO 9614 standard.

The sound pressure level is calculated according to ISO 3744 and is referred to a distance of 1/5/10 metres from the external surface of the unit.

### Technical data

Unit	40.2	50.2	60.2	70.2	80.2	90.2	100.2	115.2	130.2	145.2	160.2	180.2	
Power supply	400 - 3+N - 50				400 - 3 - 50								V-ph-Hz
Compressor type	scroll												-
N° compressors / N° refrigerant circuits	2 / 1												n°
Plant side heat exchanger type	stainless steel brazed plates												-
Source side heat exchanger type	finned coil												-
Fans type	axial												-
N° fans	2	3		2				3		4			n°
Tank volume	200				400				460				l
Hydraulic fittings	2" VICTAULIC				2" 1/2 VICTAULIC								-

### Electrical data

Standard unit	40.2	50.2	60.2	70.2	80.2	90.2	100.2	115.2	130.2	145.2	160.2	180.2	
<b>FLA</b> - Full load current at maximum tolerated conditions	40,2	45,7	53,3	58,7	69,6	75,5	90,0	97,9	106	123	136	159	A
<b>FLI</b> - Full load power input at maximum tolerated conditions	21,6	24,4	28,4	31,0	36,2	44,0	55,0	60,5	66,0	75,7	83,3	95,4	kW
<b>MIC</b> - Maximum instantaneous current of the unit	134	143	149	173	213	264	259	267	267	348	361	355	A
<b>MIC SS</b> - Maximum instantaneous current of the unit with soft starter options	89,3	96,3	101	117	143	174	175	183	183	200	246	248	A
Unit with high head modulating pump	40.2	50.2	60.2	70.2	80.2	90.2	100.2	115.2	130.2	145.2	160.2	180.2	
<b>FLA</b> - Full load current at maximum tolerated conditions	46,3	51,8	59,4	64,8	76,0	81,6	96,1	107	115	132	147	169	A
<b>FLI</b> - Full load power input at maximum tolerated conditions	25,1	27,9	31,9	34,5	42,1	47,5	58,5	65,1	70,6	80,3	89,6	102	kW
<b>MIC</b> - Maximum instantaneous current of the unit	140	150	155	179	219	270	265	276	276	357	372	365	A
<b>MIC SS</b> - Maximum instantaneous current of the unit with soft starter options	95,4	102	107	123	150	180	181	192	192	209	257	258	A

### Operative range

Temperature	Unit type	Cooling		Heating		(°C)
		min	max	min	max	
Outdoor air inlet temperature	IR, BR, IP, BP	-10*	50	-15	40*	(°C)
Water outlet temperature	IR, IP	5	25	30	55	(°C)
Water outlet temperature	BR, BP	-12	25	30	55	(°C)
Water outlet temperature (VD)	IR, BR, IP, BP	30	70	30	70	(°C)
Water outlet temperature (VR)	IR, BR	30	55	-	-	(°C)

\* with fans modulating control option (condensation / evaporation control)



## VD and VR versions

These units allow to recover the heating power, otherwise wasted on air, through an additional heat exchanger.

The **Desuperheater Version (VD)** allow the hot water production at temperatures between 30 and 70°C through the partial heat recovery of the condensation heat.

The **Total Recovery Version (VR)** allows the cold water production and, at the same time, the hot water production at temperatures between 30 and 55°C through the total recovery of the condensation heat.

### Desuperheater Version (VD) - NET NOMINAL performances

IR		Base setting up (AB)												
		40.2	50.2	60.2	70.2	80.2	90.2	100.2	115.2	130.2	145.2	160.2	180.2	
A35W7 - W45	Cooling capacity	49,1	58,1	65,5	73,3	86,7	98,6	110	125	138	159	180	205	kW
	Total power input	14,5	16,7	19,4	21,5	26,6	30,5	33,8	37,7	41,6	48,8	54,1	63,1	kW
	EER	<b>3,38</b>	<b>3,47</b>	<b>3,38</b>	<b>3,41</b>	<b>3,26</b>	<b>3,24</b>	<b>3,27</b>	<b>3,32</b>	<b>3,32</b>	<b>3,26</b>	<b>3,32</b>	<b>3,24</b>	W/W
	HRE	<b>4,36</b>	<b>4,48</b>	<b>4,36</b>	<b>4,4</b>	<b>4,21</b>	<b>4,18</b>	<b>4,22</b>	<b>4,28</b>	<b>4,29</b>	<b>4,21</b>	<b>4,29</b>	<b>4,19</b>	W/W
	Water flow rate	2,36	2,79	3,15	3,53	4,17	4,74	5,3	6,02	6,64	7,64	8,65	9,84	l/s
	Water pressure drop	26	37	36	44	34	35	37	36	38	38	41	42	kPa
	Heating recovery capacity	14,2	16,9	19	21,3	25,1	28,6	32,1	36,2	40,3	46,3	52,3	59,4	kW
	Water flow rate recovery	0,68	0,81	0,91	1,02	1,2	1,37	1,53	1,73	1,93	2,21	2,5	2,84	l/s
	Water pressure drop recovery	7	10	13	16	21	16	20	12	15	20	25	20	kPa
	IP		Base setting up (AB)											
		40.2	50.2	60.2	70.2	80.2	90.2	100.2	115.2	130.2	145.2	160.2	180.2	
A35W7 - W45	Cooling capacity	47,1	55,8	63,1	70,4	84,6	96	107	120	133	153	173	199	kW
	Total power input	14,2	16,6	18,9	21,2	26	29,5	33	36,8	40,7	47,3	53,1	61,4	kW
	EER	<b>3,32</b>	<b>3,36</b>	<b>3,33</b>	<b>3,33</b>	<b>3,25</b>	<b>3,25</b>	<b>3,25</b>	<b>3,27</b>	<b>3,27</b>	<b>3,24</b>	<b>3,26</b>	<b>3,24</b>	W/W
	HRE	<b>4,28</b>	<b>4,34</b>	<b>4,3</b>	<b>4,3</b>	<b>4,19</b>	<b>4,2</b>	<b>4,2</b>	<b>4,21</b>	<b>4,22</b>	<b>4,18</b>	<b>4,2</b>	<b>4,17</b>	W/W
	Water flow rate	2,26	2,68	3,03	3,39	4,06	4,61	5,16	5,78	6,4	7,36	8,31	9,56	l/s
	Water pressure drop	24	34	33	41	32	33	35	33	35	35	38	40	kPa
	Heating recovery capacity	13,6	16,2	18,3	20,5	24,5	27,9	31,1	34,7	38,6	44,4	50,1	57,5	kW
	Water flow rate recovery	0,65	0,77	0,87	0,98	1,17	1,33	1,49	1,66	1,84	2,12	2,39	2,75	l/s
	Water pressure drop recovery	7	9	12	14	20	16	19	11	14	18	23	19	kPa

### Total Recovery Version (VR) - NET NOMINAL performances

IR		Base setting up (AB)												
		40.2	50.2	60.2	70.2	80.2	90.2	100.2	115.2	130.2	145.2	160.2	180.2	
A35W7 - W45	Cooling capacity	49,1	58,1	65,5	73,3	86,7	98,6	110	125	138	159	180	205	kW
	Total power input	13,2	15,4	17,4	19,5	22,8	26,6	29,9	33,7	37,7	43	48,2	55,4	kW
	EER	<b>3,72</b>	<b>3,76</b>	<b>3,77</b>	<b>3,75</b>	<b>3,81</b>	<b>3,72</b>	<b>3,7</b>	<b>3,71</b>	<b>3,66</b>	<b>3,7</b>	<b>3,73</b>	<b>3,7</b>	W/W
	HRE	<b>8,39</b>	<b>8,47</b>	<b>8,49</b>	<b>8,46</b>	<b>8,55</b>	<b>8,39</b>	<b>8,35</b>	<b>8,37</b>	<b>8,27</b>	<b>8,36</b>	<b>8,42</b>	<b>8,34</b>	W/W
	Water flow rate	2,36	2,79	3,15	3,53	4,17	4,74	5,3	6,02	6,64	7,64	8,65	9,84	l/s
	Water pressure drop	26	37	36	44	34	35	37	36	38	38	41	42	kPa
	Heating recovery capacity	61,7	72,7	82,1	91,9	108	124	139	157	174	200	226	257	kW
	Water flow rate recovery	2,95	3,47	3,92	4,39	5,16	5,92	6,64	7,5	8,31	9,56	10,8	12,3	l/s
	Water pressure drop recovery	34	47	42	41	48	47	52	49	51	50	54	53	kPa

Data declared according to EN 14511. The values are referred to units without options and accessories.

**EER** (Energy Efficiency Ratio) = ratio of the total cooling capacity to the effective power input of the unit

**HRE** (Heat Recovery Efficiency) = ratio of the total capacity of the system (heating plus cooling capacity) to the effective power input

**A35W7 - W45** = source : air in 35°C d.b. / plant : water in 12°C out 7°C / Recovery : water in 40°C out 45°C

## CONTROL SYSTEM

The units are equipped with a controller designed to ensure energy saving and unit efficiency. Available functions :

- Adaptive function
- Dynamic defrost
- Sound management
- Climatic control in heating and in cooling mode
- Economy function
- Demand limit
- Integrative heating
- Remote stand by
- Remote cooling-heating



## DIMENSIONS - MINIMUM OPERATING AREA - WEIGHT

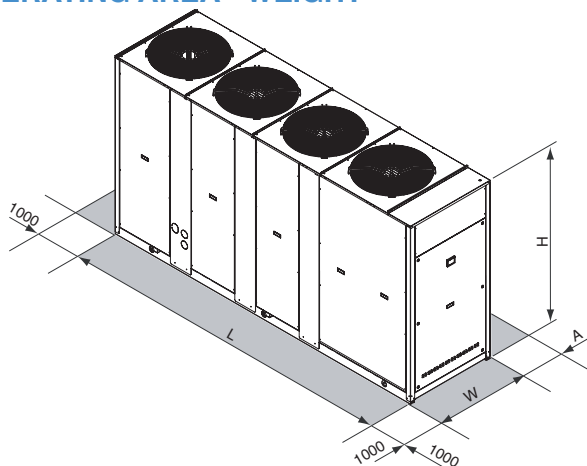

	40.2	50.2	60.2	70.2	80.2	90.2	100.2	115.2	130.2	145.2	160.2	180.2	
L		2501				3343			3343			4097	mm
W		954				1104			1104			1104	mm
H		1930				1793			2193			2193	mm
A		1600							2000				mm
Operating maximum weight*	1068	1072	1095	1132	1569	1650	1735	1877	1906	1967	2292	2350	kg

\* Weight refers to the unit IP with tank and pumping module 2 pumps.

# > RTA

## AIR-WATER CHILLERS AND HEAT PUMPS FOR OUTDOOR INSTALLATION



### Available range

#### Unit type

IR	Chiller
IP	Heat pump (reversible on the refrigerant side)
BR	Chiller Brine
BP	Heat pump Brine (reversible on the refrigerant side)

#### Version

VB	Base version
VD	Desuperheater version
VR	Total recovery version

#### Acoustic setting up

AB	Base setting up
AS	Low noise setting up
AX	eXtra low noise setting up

#### Source temperature level

M	Medium temperature level
A	High temperature level

### Unit description

This series of air-water chillers and heat pumps satisfies the cooling and heating requirements of residential plants of medium size.

All the units are suitable for outdoor installation and can be applied to fan coil plants, radiant floor plants and high efficiency radiators plants.

The refrigerant circuit, contained in a compartment protected from the air flow to simplify the maintenance operations, is equipped with scroll compressors mounted on damper supports, brazed plate heat exchanger, electronic expansion valve, re-

verse cycle valve, dehydrator filter, axial fans with safety protection grilles, finned coil made of copper pipes and aluminium louvered fins with subcooling section. The circuit is protected by a safety gas valve, high and low pressure switches and differential pressure switch on the plate heat exchanger. The plate heat exchanger and all the hydraulic pipes are thermally insulated in order to avoid condensate generation and to reduce thermal losses.

All the units can be equipped with variable speed fans control that allows the units to operate with low outdoor temperatures in cooling and high outdoor temperature in heating and permits to reduce noise emissions in such operating conditions.

The low noise acoustic setting up (AS) is obtained, starting from the base setting up (AB), reducing the rotational speed of the fans and mounting sound jackets on the compressors and the technical compartment is clad with soundproofing material of suitable thickness.

The eXtra low noise acoustic setting up (AX) is obtained, starting from the low noise setting up (AS), further reducing the rotational speed of the fans and using finned coil with bigger surface.

All the units are supplied with a management and control electrical panel containing general switch, phase presence and correct sequence controller, microprocessor controller with display and all the other electrical components with IP54 minimum protection degree.

All the units are accurately built and individually tested in the factory. Only electric and hydraulic connections are required for installation.

### Options

[Storing and pumping module](#) available in the configurations :

- Storage tank arranged as buffer on the flow or as primary-secondary buffer
- 1 or 2 pumps
- standard or high head pump
- modulating pump

#### [Compressor starting](#)

- standard (contactors)
- soft starter

#### [Fans control](#)

- on-off control
- modulating control (condensation / evaporation control)

#### [Compressor power factor correction](#)

#### [Electrical load protection](#)

- fuses
- thermal magnetic circuit breakers

#### [Coil condensate tray](#)

### Accessories

[Rubber vibration dampers](#)

[Spring vibration dampers](#)

[Coil protection grilles](#)

[Tank antifreeze electrical heater](#)

[Remote control](#)

[Modbus serial interface on RS485](#)

[Programmer clock](#)

[Phase sequence and voltage controller](#)

[Low temperature kit \(standard for IP\)](#)

[High and low pressure gauges](#)

[High temperature thermostat](#)

[Coil shut off valves](#)

[Outdoor air sensor](#)

[Water flow switch](#)

[Victaulic hydraulic fittings](#)

**NET NOMINAL performances - Standard plants - EUROVENT certified data**

IR	Base setting up (AB)	245.3	280.3	315.3	
A35W7	Cooling capacity	235	277	299	kW
	Power input	87,3	104	111	kW
	EER	2,69	2,66	2,69	W/W
	ESEER	3,86	3,85	3,89	W/W
	Water flow rate	11,3	13,4	14,4	l/s
	Pressure drops	54	60	53	kPa
IR	Low noise setting up (AS)	245.3	280.3	315.3	
A35W7	Cooling capacity	228	270	291	kW
	Power input	92,0	109	116	kW
	EER	2,48	2,48	2,51	W/W
	ESEER	3,71	3,74	3,74	W/W
	Water flow rate	11,0	13,0	14,0	l/s
	Pressure drops	51	57	50	kPa
IR	eXtra low noise setting up (AX)	245.3	280.3	315.3	
A35W7	Cooling capacity	223	264	285	kW
	Power input	94,0	111	118	kW
	EER	2,37	2,38	2,42	W/W
	ESEER	3,78	3,77	3,83	W/W
	Water flow rate	10,8	12,7	13,7	l/s
	Pressure drops	49	54	48	kPa
IP	Base setting up (AB)	245.3	280.3	315.3	
A35W7	Cooling capacity	226	268	289	kW
	Power input	85,3	101	108	kW
	EER	2,65	2,65	2,68	W/W
	ESEER	3,76	3,76	3,80	W/W
	Water flow rate	10,9	12,9	13,9	l/s
	Pressure drops	50	56	49	kPa
A7W45	Heating capacity	252	300	319	kW
	Power input	86,4	102	109	kW
	COP	2,92	2,93	2,93	W/W
	Water flow rate	11,9	14,2	15,1	l/s
Pressure drops	60	67	58	kPa	
IP	Low noise setting up (AS)	245.3	280.3	315.3	
A35W7	Cooling capacity	219	260	280	kW
	Power input	90,0	106	113	kW
	EER	2,43	2,45	2,48	W/W
	ESEER	3,60	3,61	3,64	W/W
	Water flow rate	10,6	12,5	13,5	l/s
	Pressure drops	47	52	47	kPa
A7W45	Heating capacity	242	288	306	kW
	Power input	81,6	96,9	103	kW
	COP	2,97	2,97	2,97	W/W
	Water flow rate	11,5	13,6	14,5	l/s
Pressure drops	56	62	54	kPa	
IP	eXtra low noise setting up (AX)	245.3	280.3	315.3	
A35W7	Cooling capacity	215	255	274	kW
	Power input	92,0	108	116	kW
	EER	2,34	2,36	2,36	W/W
	ESEER	3,69	3,71	3,71	W/W
	Water flow rate	10,4	12,3	13,2	l/s
	Pressure drops	46	51	45	kPa
A7W45	Heating capacity	240	285	302	kW
	Power input	79	94	100	kW
	COP	3,04	3,03	3,02	W/W
	Water flow rate	11,4	13,5	14,3	l/s
Pressure drops	55	61	52	kPa	

**NET NOMINAL performances - Radiant plants**

IR	Base setting up (AB)	245.3	280.3	315.3	
A35W18	Cooling capacity	299	353	381	kW
	Power input	94,3	112	119	kW
	EER	3,17	3,15	3,20	W/W
	Water flow rate	14,5	17,1	18,5	l/s
	Pressure drops	89	98	87	kPa
IP	Base setting up (AB)	245.3	280.3	315.3	
A35W18	Cooling capacity	288	341	368	kW
	Power input	91,9	109	116	kW
	EER	3,13	3,13	3,17	W/W
	Water flow rate	13,9	16,5	17,8	l/s
	Pressure drops	82	91	81	kPa
A7W35	Heating capacity	255	302	323	kW
	Power input	69,8	82,6	88,0	kW
	COP	3,65	3,66	3,67	W/W
	Water flow rate	12,0	14,3	15,3	l/s
	Pressure drops	61	68	60	kPa

Data declared according to EN 14511. The values are referred to units without options and accessories.

EER (Energy Efficiency Ratio) = ratio of the total cooling capacity to the effective power input of the unit

COP (Coefficient Of Performance) = ratio of the total heating capacity to the effective power input of the unit

ESEER (European Seasonal Energy Efficiency Ratio) = Unit in A CLASS.

A35W7 = source : air in 35°C d.b. / plant : water in 12°C out 7°C

A35W18 = source : air in 35°C d.b. / plant : water in 23°C out 18°C

A7W45 = source : air in 7°C d.b. 6°C w.b. / plant : water in 40°C out 45°C

A7W35 = source : air in 7°C d.b. 6°C w.b. / plant : water in 30°C out 35°C



### Acoustic performances

Base setting up (AB)	245.3	280.3	315.3	
Sound power level <sup>(E)</sup>	90	91	91	dB(A)
Sound pressure level at 1 meter	71	72	72	dB(A)
Sound pressure level at 5 meters	63	64	64	dB(A)
Sound pressure level at 10 meters	58	59	59	dB(A)
Low noise setting up (AS)	245.3	280.3	315.3	
Sound power level <sup>(E)</sup>	86	87	87	dB(A)
Sound pressure level at 1 meter	67	68	68	dB(A)
Sound pressure level at 5 meters	59	60	60	dB(A)
Sound pressure level at 10 meters	54	55	55	dB(A)
eXtra low noise setting up (AX)	245.3	280.3	315.3	
Sound power level <sup>(E)</sup>	84	85	85	dB(A)
Sound pressure level at 1 meter	65	66	66	dB(A)
Sound pressure level at 5 meters	57	58	58	dB(A)
Sound pressure level at 10 meters	52	53	53	dB(A)

(E): EUROVENT certified data

The acoustic performances are referred to units operating in cooling mode at nominal conditions A35W7.

Unit placed in free field on reflecting surface (directional factor equal to 2).

The sound power level is measured according to ISO 9614 standard.

The sound pressure level is calculated according to ISO 3744 and is referred to a distance of 1/5/10 metres from the external surface of the unit.

### Technical data

Unit	245.3	280.3	315.3	
Power supply		400 - 3 - 50		V-ph-Hz
Compressor type		scroll		-
N° compressors / N° refrigerant circuits		3 / 1		n°
Plant side heat exchanger type		stainless steel brazed plates		-
Source side heat exchanger type		finned coil		-
Fans type		axial		-
N° fans	4		5	n°
Tank volume		460		l
Hydraulic fittings		3" VICTAULIC		-

### Electrical data

Standard unit	245.3	280.3	315.3	
<b>FLA</b> - Full load current at maximum tolerated conditions	199	231	247	A
<b>FLI</b> - Full load power input at maximum tolerated conditions	121	137	148	kW
<b>MIC</b> - Maximum instantaneous current of the unit	425	428	470	A
<b>MIC SS</b> - Maximum instantaneous current of the unit with soft starter options	311	313	351	A
Unit with high head modulating pump	245.3	280.3	315.3	
<b>FLA</b> - Full load current at maximum tolerated conditions	213	245	261	A
<b>FLI</b> - Full load power input at maximum tolerated conditions	130	146	157	kW
<b>MIC</b> - Maximum instantaneous current of the unit	439	442	483	A
<b>MIC SS</b> - Maximum instantaneous current of the unit with soft starter options	324	327	364	A

### Operative range

Temperature	Unit type	Cooling		Heating		
		min	max	min	max	
Outdoor air inlet temperature	IR, BR, IP, BP	-10*	50	-10	40*	(°C)
Water outlet temperature	IR, IP	5	25	30	55	(°C)
Water outlet temperature	BR, BP	-12	25	30	55	(°C)
Water outlet temperature (VD)	IR, BR, IP, BP	30	70	30	70	(°C)
Water outlet temperature (VR)	IR, BR	30	55	-	-	(°C)

\* with fans modulating control option (condensation / evaporation control)

## VD and VR versions

These units allow to recover the heating power, otherwise wasted on air, through an additional heat exchanger.

The **Desuperheater Version (VD)** allow the hot water production at temperatures between 30 and 70°C through the partial heat recovery of the condensation heat.

The **Total Recovery Version (VR)** allows the cold water production and, at the same time, the hot water production at temperatures between 30 and 55°C through the total recovery of the

### Desupeheater Version (VD) - NET NOMINAL performances

IR	Base setting up (AB)	245.3	280.3	315.3	
A35W7 - W45	Cooling capacity	244	288	311	kW
	Total power input	85,3	101,0	107,6	kW
	EER	2,86	2,85	2,89	W/W
	HRE	3,77	3,75	3,80	W/W
	Water flow rate	11,8	13,9	15,0	l/s
	Water pressure drop	59	65	57	kPa
	Heating recovery capacity	77,3	90,8	97,7	kW
	Water flow rate recovery	3,69	4,34	4,67	l/s
	Water pressure drop recovery	30	19	20	kPa

IP	Base setting up (AB)	245.3	280.3	315.3	
A35W7 - W45	Cooling capacity	235	278	300	kW
	Total power input	83,2	98,7	105,2	kW
	EER	2,82	2,82	2,85	W/W
	HRE	3,73	3,72	3,76	W/W
	Water flow rate	11,3	13,4	14,5	l/s
	Water pressure drop	54	60	54	kPa
	Heating recovery capacity	75,5	88,7	95,5	kW
	Water flow rate recovery	3,61	4,24	4,56	l/s
	Water pressure drop recovery	29	18	19	kPa

### Total Recovery Version (VR) - NET NOMINAL performances

IR	Base setting up (AB)	245.3	280.3	315.3	
A35W7 - W45	Cooling capacity	246	291	314	kW
	Total power input	77,4	91,2	97,7	kW
	EER	3,19	3,19	3,21	W/W
	HRE	7,32	7,34	7,38	W/W
	Water flow rate	11,9	14,0	15,2	l/s
	Water pressure drop	60	66	59	kPa
	Heating recovery capacity	320	378	407	kW
	Water flow rate recovery	15,3	18,1	19,4	l/s
	Water pressure drop recovery	51	55	68	kPa

Data declared according to EN 14511. The values are referred to units without options and accessories.

**EER** (Energy Efficiency Ratio) = ratio of the total cooling capacity to the effective power input of the unit

**HRE** (Heat Recovery Efficiency) = ratio of the total capacity of the system (heating plus cooling capacity) to the effective power input

**A35W7 - W45** = source : air in 35°C d.b. / plant : water in 12°C out 7°C / Recovery : water in 40°C out 45°C

## CONTROL SYSTEM

The units are equipped with a controller designed to ensure energy saving and unit efficiency. Available functions :

- Adaptive function
- Dynamic defrost
- Sound management
- Climatic control in heating and in cooling mode
- Economy function
- Demand limit
- Integrative heating
- Remote stand by
- Remote cooling-heating

## DIMENSIONS - MINIMUM OPERATING AREA - WEIGHT

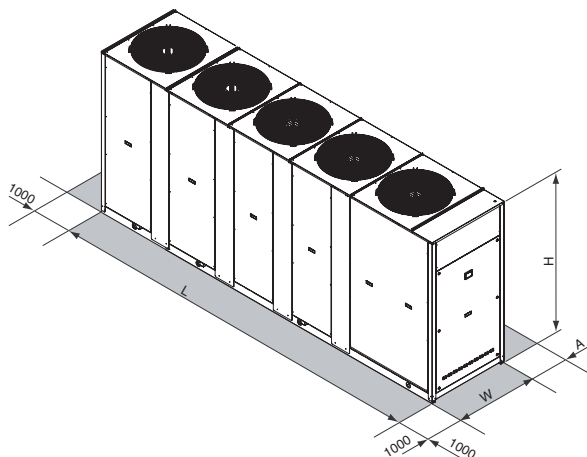

	245.3	280.3	315.3	
L		5020		mm
W		1104		mm
H		2197		mm
A		2000		mm
Operating maximum weight*	2663	2744	2841	kg

\* Weight refers to the unit IP with tank and pumping module 2 pumps.

# > RLA

## AIR-WATER CHILLERS AND HEAT PUMPS FOR OUTDOOR INSTALLATION



### Available range

#### Unit type

IR	Chiller
IP	Heat pump (reversible on the refrigerant side)
BR	Chiller Brine
BP	Heat pump Brine (reversible on the refrigerant side)

#### Version

VB	Base version
VD	Desuperheater version
VR	Total recovery version

#### Acoustic setting up

AB	Base setting up
AS	Low noise setting up
AX	eXtra low noise setting up

#### Source temperature level

M	Medium temperature level
A	High temperature level

### Unit description

This series of air-water chillers and heat pumps satisfies the cooling and heating requirements of residential plants of medium-large size.

All the units are suitable for outdoor installation and can be applied to fan coil plants, radiant floor plants and high efficiency radiators plants.

The refrigerant circuit, contained in a compartment protected from the air flow to simplify the maintenance operations, is equipped with scroll compressors mounted on damper supports, brazed plate heat exchanger, electronic expan-

sion valve, reverse cycle valve, dehydrator filter, axial fans with safety protection grilles, finned coil made of copper pipes and aluminium louvered fins with subcooling section. The circuit is protected by a safety gas valve, high and low pressure switches and differential pressure switch on the plate heat exchanger. The plate heat exchanger and all the hydraulic pipes are thermally insulated in order to avoid condensate generation and to reduce thermal losses.

All the units can be equipped with variable speed fans control that allows the units to operate with low outdoor temperatures in cooling and high outdoor temperature in heating and permits to reduce noise emissions in such operating conditions.

The low noise acoustic setting up (AS) is obtained, starting from the base setting up (AB), reducing the rotational speed of the fans and mounting sound jackets on the compressors and the technical compartment is clad with soundproofing material of suitable thickness.

The eXtra low noise acoustic setting up (AX) is obtained, starting from the low noise setting up (AS), further reducing the rotational speed of the fans and using finned coil with bigger surface.

All the units are supplied with a management and control electrical panel containing general switch, phase presence and correct sequence controller, microprocessor controller with display and all the other electrical components with IP54 minimum protection degree.

All the units are accurately built and individually tested in the factory. Only electric and hydraulic connections are required for installation.

### Options

[Storing and pumping module](#) available in the configurations :

- storage tank arranged as buffer on the flow or as primary-secondary buffer
- 1 or 2 pumps

• standard or high head pump

[Refrigerant circuit pressures visualization](#)

- high and low pressure gauges
- high and low pressure transducers

[High temperature thermostat](#)

[Compressor starting](#)

- standard (contactors)
- soft starter

[Fans control](#)

- on-off control
- modulating control (condensation / evaporation control)

[Compressor power factor correction](#)

[Electrical load protection](#)

- fuses
- thermal magnetic circuit breakers

[Coil condensate tray](#)

### Accessories

[Rubber vibration dampers](#)

[Spring vibration dampers](#)

[Coil protection grilles](#)

[Tank antifreeze electrical heater](#)

[Remote control](#)

[Modbus serial interface on RS485](#)

[Programmer clock](#)

[Phase sequence and voltage controller](#)

[Water flow switch](#)

[Victaulic hydraulic fittings](#)



**NET NOMINAL performances - Standard plants - EUROVENT certified data**

IR	Base setting up (AB)	160.4	180.4	200.4	230.4	260.4	290.4	330.4	375.4	420.4	
A35W7	Cooling capacity	161	178	199	228	255	289	323	368	409	kW
	Power input	56,2	62,7	70,9	80,4	90,7	103	115	130	146	kW
	EER	2,86	2,84	2,81	2,84	2,81	2,81	2,81	2,83	2,80	W/W
	ESEER	3,84	3,81	3,79	3,82	3,79	3,80	3,79	3,80	3,79	W/W
	Water flow rate	7,74	8,55	9,60	11,0	12,3	14,0	15,6	17,7	19,7	l/s
	Pressure drops	51	51	58	57	60	64	54	58	58	kPa
IR	Low noise setting up (AS)	160.4	180.4	200.4	230.4	260.4	290.4	330.4	375.4	420.4	
A35W7	Cooling capacity	155	171	191	219	245	277	311	353	393	kW
	Power input	59,2	66,1	75,0	85,2	95,5	109	121	137	154	kW
	EER	2,62	2,59	2,55	2,57	2,57	2,54	2,57	2,58	2,55	W/W
	ESEER	3,85	3,80	3,77	3,80	3,79	3,76	3,78	3,80	3,76	W/W
	Water flow rate	7,45	8,22	9,22	10,6	11,8	13,4	15,0	17,0	18,9	l/s
	Pressure drops	47	47	53	53	56	58	50	53	54	kPa
IR	eXtra low noise setting up (AX)	160.4	180.4	200.4	230.4	260.4	290.4	330.4	375.4	420.4	
A35W7	Cooling capacity	151	167	187	214	240	272	304	346	385	kW
	Power input	59,8	66,9	76,0	86,4	96,6	111	123	138	157	kW
	EER	2,53	2,50	2,46	2,48	2,48	2,45	2,47	2,51	2,45	W/W
	ESEER	3,90	3,85	3,82	3,84	3,86	3,82	3,82	3,88	3,81	W/W
	Water flow rate	7,26	8,03	9,03	10,3	11,6	13,1	14,6	16,7	18,5	l/s
	Pressure drops	45	45	51	50	54	56	47	51	51	kPa
IP	Base setting up (AB)	160.4	180.4	200.4	230.4	260.4	290.4	330.4	375.4	420.4	
A35W7	Cooling capacity	154	171	192	215	244	275	310	357	397	kW
	Power input	55,4	61,8	69,6	78,5	89,9	102	113	129	144	kW
	EER	2,78	2,77	2,76	2,74	2,71	2,70	2,74	2,77	2,76	W/W
	ESEER	3,72	3,70	3,72	3,68	3,65	3,65	3,66	3,72	3,73	W/W
	Water flow rate	7,41	8,22	9,27	10,4	11,8	13,3	14,9	17,2	19,2	l/s
	Pressure drops	47	47	54	51	56	57	49	54	55	kPa
A7W45	Heating capacity	169	191	215	240	273	308	345	395	439	kW
	Power input	56,8	64,0	72,3	81,2	92,7	104	116	132	147	kW
	COP	2,98	2,98	2,97	2,96	2,94	2,96	2,97	2,99	2,99	W/W
	Water flow rate	8,03	9,03	10,2	11,4	12,9	14,6	16,3	18,7	20,8	l/s
Pressure drops	55	57	65	62	66	69	59	64	65	kPa	
IP	Low noise setting up (AS)	160.4	180.4	200.4	230.4	260.4	290.4	330.4	375.4	420.4	
A35W7	Cooling capacity	148	164	185	206	234	265	298	343	382	kW
	Power input	58,3	65,2	73,6	86,4	94,7	107	123	136	152	kW
	EER	2,54	2,52	2,51	2,38	2,47	2,48	2,42	2,52	2,51	W/W
	ESEER	3,72	3,69	3,69	3,51	3,64	3,63	3,55	3,73	3,70	W/W
	Water flow rate	7,12	7,88	8,89	9,94	11,3	12,8	14,3	16,5	18,4	l/s
	Pressure drops	43	44	49	47	51	53	45	50	51	kPa
A7W45	Heating capacity	162	183	206	230	262	296	331	379	422	kW
	Power input	53,5	60,3	68,2	76,6	87,3	99	110	125	140	kW
	COP	3,03	3,03	3,02	3,00	3,00	2,99	3,01	3,03	3,01	W/W
	Water flow rate	7,69	8,65	9,75	10,9	12,4	14,0	15,7	17,9	20,0	l/s
Pressure drops	50	52	59	56	61	64	54	59	60	kPa	
IP	eXtra low noise setting up (AX)	160.4	180.4	200.4	230.4	260.4	290.4	330.4	375.4	420.4	
A35W7	Cooling capacity	145	161	181	203	229	259	291	335	374	kW
	Power input	59,0	66,1	74,6	84,4	95,8	109	122	137	153	kW
	EER	2,46	2,44	2,43	2,41	2,39	2,38	2,39	2,45	2,44	W/W
	ESEER	3,79	3,75	3,75	3,71	3,70	3,69	3,69	3,79	3,77	W/W
	Water flow rate	6,98	7,74	8,70	9,75	11,0	12,5	14,0	16,1	18,0	l/s
	Pressure drops	42	42	47	45	48	51	43	48	49	kPa
A7W45	Heating capacity	161	181	204	228	259	293	328	374	417	kW
	Power input	51,8	58,5	66,2	74,5	84,6	95,6	106	121	135	kW
	COP	3,11	3,09	3,08	3,06	3,06	3,06	3,09	3,09	3,09	W/W
	Water flow rate	7,64	8,60	9,65	10,8	12,3	13,9	15,5	17,7	19,7	l/s
Pressure drops	50	52	58	55	60	63	53	58	58	kPa	

**NET NOMINAL performances - Radiant plants**

IR	Base setting up (AB)	160.4	180.4	200.4	230.4	260.4	290.4	330.4	375.4	420.4	
A35W18	Cooling capacity	205	226	253	290	324	368	411	468	521	kW
	Power input	60,5	67,5	76,7	87,0	98,0	112	124	140	158	kW
	EER	3,39	3,35	3,30	3,33	3,31	3,29	3,31	3,34	3,30	W/W
	Water flow rate	9,91	10,9	12,3	14,1	15,7	17,9	19,9	22,7	25,3	l/s
Pressure drops	84	83	95	94	98	104	87	95	96	kPa	
IP	Base setting up (AB)	160.4	180.4	200.4	230.4	260.4	290.4	330.4	375.4	420.4	
A35W18	Cooling capacity	196	217	245	274	310	351	394	454	506	kW
	Power input	59,4	66,4	75,1	84,6	96,8	110	122	139	154	kW
	EER	3,30	3,27	3,26	3,24	3,20	3,19	3,23	3,27	3,29	W/W
	Water flow rate	9,48	10,5	11,9	13,3	15,0	17,0	19,1	22,0	24,5	l/s
Pressure drops	77	77	89	84	90	94	80	89	90	kPa	
A7W35	Heating capacity	180	202	228	255	290	327	366	419	466	kW
	Power input	49,8	56,1	63,3	70,9	81,4	91,6	101	116	129	kW
	COP	3,61	3,60	3,60	3,60	3,56	3,57	3,62	3,61	3,61	W/W
	Water flow rate	8,51	9,57	10,8	12,1	13,7	15,4	17,3	19,8	22,0	l/s
Pressure drops	62	64	73	69	75	77	66	72	73	kPa	

Data declared according to EN 14511. The values are referred to units without options and accessories.

EER (Energy Efficiency Ratio) = ratio of the total cooling capacity to the effective power input of the unit

COP (Coefficient Of Performance) = ratio of the total heating capacity to the effective power input of the unit

ESEER (European Seasonal Energy Efficiency Ratio) = Unit in A CLASS.

A35W7 = source : air in 35°C d.b. / plant : water in 12°C out 7°C

A35W18 = source : air in 35°C d.b. / plant : water in 23°C out 18°C

A7W45 = source : air in 7°C d.b. 6°C w.b. / plant : water in 40°C out 45°C

A7W35 = source : air in 7°C d.b. 6°C w.b. / plant : water in 30°C out 35°C

### Acoustic performances

Base setting up (AB)	160.4	180.4	200.4	230.4	260.4	290.4	330.4	375.4	420.4	
Sound power level <sup>(E)</sup>	91	92	92	92	93	94	94	95	95	dB(A)
Sound pressure level at 1 meter	72	73	73	73	74	75	74	75	75	dB(A)
Sound pressure level at 5 meters	64	65	65	65	66	67	67	68	68	dB(A)
Sound pressure level at 10 meters	59	60	60	60	61	62	62	63	63	dB(A)
Low noise setting up (AS)	160.4	180.4	200.4	230.4	260.4	290.4	330.4	375.4	420.4	
Sound power level <sup>(E)</sup>	85	86	86	86	87	88	88	89	89	dB(A)
Sound pressure level at 1 meter	66	67	67	67	68	69	68	69	69	dB(A)
Sound pressure level at 5 meters	58	59	59	59	60	61	61	62	62	dB(A)
Sound pressure level at 10 meters	53	54	54	54	55	56	56	57	57	dB(A)
eXtra low noise setting up (AX)	160.4	180.4	200.4	230.4	260.4	290.4	330.4	375.4	420.4	
Sound power level <sup>(E)</sup>	82	83	83	83	84	85	85	86	86	dB(A)
Sound pressure level at 1 meter	63	64	64	64	65	66	65	66	66	dB(A)
Sound pressure level at 5 meters	55	56	56	56	57	58	58	59	59	dB(A)
Livello di pressione sonora a 10 metri	50	51	51	51	52	53	53	54	54	dB(A)

#### (E): EUROVENT certified data

The acoustic performances are referred to units operating in cooling mode at nominal conditions A35W7.

Unit placed in free field on reflecting surface (directional factor equal to 2).

The sound power level is measured according to ISO 9614 standard.

The sound pressure level is calculated according to ISO 3744 and is referred to a distance of 1/5/10 metres from the external surface of the unit.

### Technical data

Unit	160.4	180.4	200.4	230.4	260.4	290.4	330.4	375.4	420.4	
Power supply	400 - 3 - 50									V-ph-Hz
Compressor type	scroll									-
N° compressors / N° refrigerant circuits	4 / 2									n°
Plant side heat exchanger type	stainless steel brazed plates									-
Source side heat exchanger type	finned coil									-
Fans type	axial									-
N° fans	4			6			8			n°
Tank volume	325						710			l
Hydraulic fittings	3" VICTAULIC						4" VICTAULIC			-

### Electrical data

Standard unit	160.4	180.4	200.4	230.4	260.4	290.4	330.4	375.4	420.4	
<b>FLA</b> - Full load current at maximum tolerated conditions	140	151	177	193	217	243	269	314	335	A
<b>FLI</b> - Full load power input at maximum tolerated conditions	76	87	107	118	133	148	163	186	200	kW
<b>MIC</b> - Maximum instantaneous current of the unit	283	340	347	355	379	469	495	510	558	A
<b>MIC SS</b> - Maximum instantaneous current of the unit with soft starter options	213	250	263	271	295	354	380	404	438	A
Unit with high head modulating pump	160.4	180.4	200.4	230.4	260.4	290.4	330.4	375.4	420.4	
<b>FLA</b> - Full load current at maximum tolerated conditions	149	160	187	203	227	256	282	327	357	A
<b>FLI</b> - Full load power input at maximum tolerated conditions	81	91	113	124	139	156	171	194	212	kW
<b>MIC</b> - Maximum instantaneous current of the unit	292	348	357	365	389	482	508	524	580	A
<b>MIC SS</b> - Maximum instantaneous current of the unit with soft starter options	222	258	273	281	305	368	394	417	460	A

### Operative range

Temperature	Unit type	Cooling		Heating		
		min	max	min	max	
Outdoor air inlet temperature	IR, BR, IP, BP	-10*	55**	-10	40*	(°C)
Water outlet temperature	IR, IP	5	25	30	55	(°C)
Water outlet temperature	BR, BP	-12	25	30	55	(°C)
Water outlet temperature (VD)	IR, BR, IP, BP	30	70	30	70	(°C)
Water outlet temperature (VR)	IR, BR	30	55	-	-	(°C)

\* with fans modulating control option (condensation / evaporation control)

\*\* with ATC outdoor high temperature protection function

## VD and VR versions

These units allow to recover the heating power, otherwise wasted on air, through an additional heat exchanger.

The **Desuperheater Version (VD)** allow the hot water production at temperatures between 30 and 70°C through the partial heat recovery of the condensation heat.

**The Total Recovery Version (VR)** allows the cold water production and, at the same time, the hot water production at temperatures between 30 and 55°C through the total recovery of the condensation heat.

### Desupeheater Version (VD) - NET NOMINAL performances

IR	Base setting up (AB)	160.4	180.4	200.4	230.4	260.4	290.4	330.4	375.4	420.4	
A35W7 - W45	Cooling capacity	167	185	207	237	264	300	336	382	425	kW
	Total power input	55,0	61,2	69,3	78,5	88,7	101	112	127	143	kW
	<b>EER</b>	<b>3,04</b>	<b>3,01</b>	<b>2,99</b>	<b>3,02</b>	<b>2,98</b>	<b>2,97</b>	<b>3,00</b>	<b>3,01</b>	<b>2,98</b>	W/W
	<b>HRE</b>	<b>3,90</b>	<b>3,89</b>	<b>3,87</b>	<b>3,91</b>	<b>3,85</b>	<b>3,85</b>	<b>3,90</b>	<b>3,88</b>	<b>3,86</b>	W/W
	Water flow rate	8,05	8,89	10,0	11,4	12,8	14,5	16,2	18,4	20,5	l/s
	Water pressure drop	55	55	63	62	65	68	58	62	63	kPa
	Heating recovery capacity	47,2	53,4	61,2	70,3	76,6	88,7	99,9	110,8	126,6	kW
	Water flow rate recovery	2,25	2,55	2,93	3,36	3,66	4,24	4,77	5,29	6,05	l/s
	Water pressure drop recovery	5	7	8	10	13	16	16	21	25	kPa
	IP	Base setting up (AB)	160.4	180.4	200.4	230.4	260.4	290.4	330.4	375.4	420.4
A35W7 - W45	Cooling capacity	160	177	200	224	253	286	322	371	413	kW
	Total power input	54,1	60,4	67,9	76,6	87,8	99	111	126	140	kW
	<b>EER</b>	<b>2,96</b>	<b>2,94</b>	<b>2,94</b>	<b>2,92</b>	<b>2,89</b>	<b>2,88</b>	<b>2,91</b>	<b>2,95</b>	<b>2,96</b>	W/W
	<b>HRE</b>	<b>3,82</b>	<b>3,81</b>	<b>3,83</b>	<b>3,82</b>	<b>3,75</b>	<b>3,76</b>	<b>3,81</b>	<b>3,83</b>	<b>3,85</b>	W/W
	Water flow rate	7,70	8,55	9,64	10,8	12,2	13,8	15,5	17,9	19,9	l/s
	Water pressure drop	51	51	58	55	59	62	53	59	59	kPa
	Heating recovery capacity	46,5	52,7	60,1	68,8	76,1	87,5	98,9	110	124	kW
	Water flow rate recovery	2,22	2,52	2,87	3,29	3,64	4,18	4,73	5,25	5,91	l/s
	Water pressure drop recovery	5	6	8	10	13	16	16	20	24	kPa

### Total Recovery Version (VR) - NET NOMINAL performances

IR	Base setting up (AB)	160.4	180.4	200.4	230.4	260.4	290.4	330.4	375.4	420.4	
A35W7 - W45	Cooling capacity	169	186	209	239	267	303	339	386	429	kW
	Total power input	47,3	53,5	61,6	70,7	77,2	89,5	100	111	127	kW
	<b>EER</b>	<b>3,56</b>	<b>3,48</b>	<b>3,39</b>	<b>3,38</b>	<b>3,46</b>	<b>3,39</b>	<b>3,38</b>	<b>3,46</b>	<b>3,37</b>	W/W
	<b>HRE</b>	<b>8,08</b>	<b>7,91</b>	<b>7,75</b>	<b>7,71</b>	<b>7,87</b>	<b>7,72</b>	<b>7,71</b>	<b>7,87</b>	<b>7,69</b>	W/W
	Water flow rate	8,13	8,98	10,1	11,5	12,9	14,6	16,4	18,6	20,7	l/s
	Water pressure drop	56	57	64	63	66	69	59	64	64	kPa
	Heating recovery capacity	214	237	268	306	340	388	434	492	550	kW
	Water flow rate recovery	10,2	11,3	12,8	14,6	16,2	18,5	20,7	23,5	26,3	l/s
	Water pressure drop recovery	45	43	45	45	47	49	49	51	51	kPa

Data declared according to EN 14511. The values are referred to units without options and accessories.

**EER** (Energy Efficiency Ratio) = ratio of the total cooling capacity to the effective power input of the unit

**HRE** (Heat Recovery Efficiency) = ratio of the total capacity of the system (heating plus cooling capacity) to the effective power input

**A35W7 - W45** = source : air in 35°C d.b. / plant : water in 12°C out 7°C / Recovery : water in 40°C out 45°C

## CONTROL SYSTEM

The units are equipped with a controller designed to ensure energy saving and unit efficiency. Available functions :

- ATC outdoor high temperature protection function
- Dynamic defrost
- Sound management
- Climatic control in heating and in cooling mode
- Double set point function
- Demand limit
- Integrative heating
- Remote stand by
- Remote cooling-heating



## DIMENSIONS - MINIMUM OPERATING AREA - WEIGHT

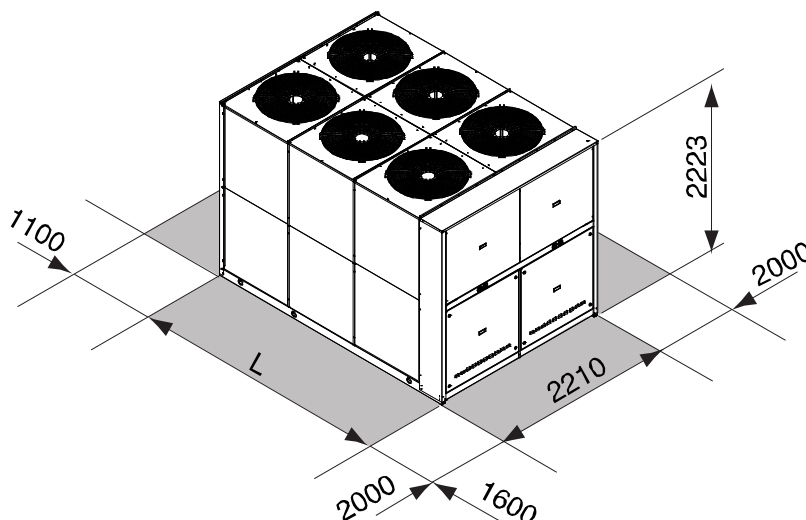

	160.4	180.4	200.4	230.4	260.4	290.4	330.4	375.4	420.4	
L	3164	3164	3164	3164	3164	3164	4097	4097	4097	mm
Operating maximum weight*	2642	2752	2867	3008	3107	3178	3749	3864	3986	kg

\* Weight refers to the unit IP with tank and pumping module 2 pumps.



# > RLA HE

## AIR-WATER CHILLERS AND HEAT PUMPS FOR OUTDOOR INSTALLATION



### Available range

#### Unit type

IR	Chiller
IP	Heat pump (reversible on the refrigerant side)
BR	Chiller Brine
BP	Heat pump Brine (reversible on the refrigerant side)

#### Version

VB	Base version
VD	Desuperheater version
VR	Total recovery version

#### Acoustic setting up

AB	Base setting up
AS	Low noise setting up
AX	eXtra low noise setting up

#### Source temperature level

M	Medium temperature level
A	High temperature level

### Unit description

This series of air-water chillers and heat pumps satisfies the cooling and heating requirements of residential plants of medium-large size.

All the units are suitable for outdoor installation and can be applied to fan coil plants, radiant floor plants and high efficiency radiators plants.

The refrigerant circuit, contained in a compartment protected from the air flow to simplify the maintenance operations, is equipped with scroll compressors mounted on damper supports, brazed plate heat exchanger, electronic expansion valve, reverse cycle valve, dehydrator filter, axial fans with safety protection

grilles, finned coil made of copper pipes and aluminium louvered fins with sub-cooling section. The circuit is protected by a safety gas valve, high and low pressure switches and differential pressure switch on the plate heat exchanger. The plate heat exchanger and all the hydraulic pipes are thermally insulated in order to avoid condensate generation and to reduce thermal losses.

All the units can be equipped with variable speed fans control that allows the units to operate with low outdoor temperatures in cooling and high outdoor temperature in heating and permits to reduce noise emissions in such operating conditions.

The low noise acoustic setting up (AS) is obtained, starting from the base setting up (AB), reducing the rotational speed of the fans and mounting sound jackets on the compressors and the technical compartment is clad with soundproofing material of suitable thickness.

The eXtra low noise acoustic setting up (AX) is obtained, starting from the low noise setting up (AS), further reducing the rotational speed of the fans and using finned coil with bigger surface.

All the units are supplied with a management and control electrical panel containing general switch, phase presence and correct sequence controller, microprocessor controller with display and all the other electrical components with IP54 minimum protection degree.

All the units are accurately built and individually tested in the factory. Only electric and hydraulic connections are required for installation.

### Options

Storing and pumping module available in the configurations :

- storage tank arranged as buffer on the flow or as primary-secondary buffer
- 1 or 2 pumps
- standard or high head pump

#### Refrigerant circuit pressures visualization

- high and low pressure gauges
- high and low pressure transducers

#### High temperature thermostat

#### Compressor starting

- standard (contactors)
- soft starter

#### Fans control

- on-off control
- modulating control (condensation / evaporation control)

#### Compressor power factor correction

#### Electrical load protection

- fuses
- thermal magnetic circuit breakers

#### Coil condensate tray

### Accessories

Rubber vibration dampers

Spring vibration dampers

Coil protection grilles

Tank antifreeze electrical heater

Remote control

Modbus serial interface on RS485

Programmer clock

Phase sequence and voltage controller

Water flow switch

Victaulic hydraulic fittings

**NET NOMINAL performances - Standard plants - EUROVENT certified data**

IR	Base setting up (AB)	160.4	180.4	200.4	230.4	260.4	290.4	330.4	375.4	
A35W7	Cooling capacity	172	191	212	237	267	304	340	387	kW
	Power input	52,7	58,0	65,4	74,1	83,6	95	106	122	kW
	<b>EER</b>	<b>3,26</b>	<b>3,29</b>	<b>3,24</b>	<b>3,20</b>	<b>3,19</b>	<b>3,20</b>	<b>3,21</b>	<b>3,17</b>	W/W
	<b>ESEER</b>	<b>4,57</b>	<b>4,61</b>	<b>4,54</b>	<b>4,48</b>	<b>4,47</b>	<b>4,48</b>	<b>4,49</b>	<b>4,44</b>	W/W
	Water flow rate	8,22	9,13	10,13	11,3	12,8	14,5	16,2	18,5	l/s
	Pressure drops	39	36	38	39	40	36	36	33	kPa
IR	Low noise setting up (AS)	160.4	180.4	200.4	230.4	260.4	290.4	330.4	375.4	
A35W7	Cooling capacity	165	183	204	228	256	292	326	372	kW
	Power input	55,6	61,4	69,4	78,8	88,3	100,7	113	130	kW
	<b>EER</b>	<b>2,97</b>	<b>2,98</b>	<b>2,94</b>	<b>2,89</b>	<b>2,90</b>	<b>2,90</b>	<b>2,89</b>	<b>2,86</b>	W/W
	<b>ESEER</b>	<b>4,57</b>	<b>4,59</b>	<b>4,53</b>	<b>4,46</b>	<b>4,46</b>	<b>4,47</b>	<b>4,45</b>	<b>4,41</b>	W/W
	Water flow rate	7,88	8,74	9,75	10,9	12,2	14,0	15,6	17,8	l/s
	Pressure drops	36	33	35	36	36	33	34	31	kPa
IR	eXtra low noise setting up (AX)	160.4	180.4	200.4	230.4	260.4	290.4	330.4	375.4	
A35W7	Cooling capacity	162	180	199	223	251	286	320	364	kW
	Power input	56,3	62,2	70,4	80,1	89,4	102	114	132	kW
	<b>EER</b>	<b>2,88</b>	<b>2,89</b>	<b>2,83</b>	<b>2,78</b>	<b>2,81</b>	<b>2,80</b>	<b>2,82</b>	<b>2,77</b>	W/W
	<b>ESEER</b>	<b>4,66</b>	<b>4,69</b>	<b>4,58</b>	<b>4,51</b>	<b>4,55</b>	<b>4,53</b>	<b>4,56</b>	<b>4,48</b>	W/W
	Water flow rate	7,74	8,60	9,51	10,7	12,0	13,7	15,3	17,4	l/s
	Pressure drops	34	32	33	35	35	32	32	29	kPa
IP	Base setting up (AB)	160.4	180.4	200.4	230.4	260.4	290.4	330.4	375.4	
A35W7	Cooling capacity	169	187	208	234	266	301	339	385	kW
	Power input	52,7	58,0	65,3	73,3	83,2	94,0	106	121	kW
	<b>EER</b>	<b>3,22</b>	<b>3,23</b>	<b>3,19</b>	<b>3,19</b>	<b>3,20</b>	<b>3,20</b>	<b>3,20</b>	<b>3,18</b>	W/W
	<b>ESEER</b>	<b>4,50</b>	<b>4,52</b>	<b>4,46</b>	<b>4,47</b>	<b>4,48</b>	<b>4,48</b>	<b>4,48</b>	<b>4,45</b>	W/W
	Water flow rate	8,09	8,95	9,94	11,2	12,7	14,4	16,2	18,4	l/s
	Pressure drops	38	35	36	38	39	35	36	33	kPa
A7W45	Heating capacity	176	196	218	242	279	316	351	401	kW
	Power input	52,6	59,9	66,7	74,6	85,9	97	107	124	kW
	<b>COP</b>	<b>3,34</b>	<b>3,28</b>	<b>3,27</b>	<b>3,24</b>	<b>3,25</b>	<b>3,26</b>	<b>3,28</b>	<b>3,23</b>	W/W
	Water flow rate	8,39	9,37	10,4	11,6	13,3	15,1	16,8	19,2	l/s
	Pressure drops	41	38	40	41	43	39	39	36	kPa
	IP	Low noise setting up (AS)	160.4	180.4	200.4	230.4	260.4	290.4	330.4	375.4
A35W7	Cooling capacity	163	180	200	225	255	289	325	370	kW
	Power input	55,6	61,4	69,2	77,9	87,9	99,6	113	129	kW
	<b>EER</b>	<b>2,93</b>	<b>2,93</b>	<b>2,89</b>	<b>2,89</b>	<b>2,90</b>	<b>2,90</b>	<b>2,88</b>	<b>2,87</b>	W/W
	<b>ESEER</b>	<b>4,51</b>	<b>4,51</b>	<b>4,45</b>	<b>4,45</b>	<b>4,47</b>	<b>4,47</b>	<b>4,44</b>	<b>4,42</b>	W/W
	Water flow rate	7,79	8,60	9,56	10,75	12,2	13,8	15,5	17,7	l/s
	Pressure drops	35	32	34	35	36	32	33	30	kPa
A7W45	Heating capacity	169	188	209	232	268	303	337	385	kW
	Power input	49,6	56,5	63,0	70,5	81,0	91,3	101	117	kW
	<b>COP</b>	<b>3,41</b>	<b>3,33</b>	<b>3,32</b>	<b>3,29</b>	<b>3,31</b>	<b>3,32</b>	<b>3,35</b>	<b>3,29</b>	W/W
	Water flow rate	8,07	8,98	9,99	11,1	12,8	14,5	16,1	18,4	l/s
	Pressure drops	37	35	37	37	40	36	36	33	kPa
	IP	eXtra low noise setting up (AX)	160.4	180.4	200.4	230.4	260.4	290.4	330.4	375.4
A35W7	Cooling capacity	159	176	196	220	250	283	319	362	kW
	Power input	56,3	62,2	70,3	79,2	89,0	101	114	131	kW
	<b>EER</b>	<b>2,82</b>	<b>2,83</b>	<b>2,79</b>	<b>2,78</b>	<b>2,81</b>	<b>2,80</b>	<b>2,81</b>	<b>2,77</b>	W/W
	<b>ESEER</b>	<b>4,58</b>	<b>4,58</b>	<b>4,52</b>	<b>4,50</b>	<b>4,55</b>	<b>4,54</b>	<b>4,55</b>	<b>4,49</b>	W/W
	Water flow rate	7,60	8,41	9,36	10,51	11,9	13,5	15,2	17,3	l/s
	Pressure drops	33	31	32	34	34	31	32	29	kPa
A7W45	Heating capacity	167	186	207	230	265	300	333	381	kW
	Power input	48,0	54,8	61,1	68,5	78,4	89	98	113	kW
	<b>COP</b>	<b>3,48</b>	<b>3,39</b>	<b>3,39</b>	<b>3,36</b>	<b>3,38</b>	<b>3,39</b>	<b>3,40</b>	<b>3,39</b>	W/W
	Water flow rate	7,98	8,89	9,89	11,0	12,7	14,3	15,9	18,2	l/s
	Pressure drops	37	34	36	37	39	35	35	32	kPa

**NET NOMINAL performances - Radiant plants**

IR	Base setting up (AB)	160.4	180.4	200.4	230.4	260.4	290.4	330.4	375.4	
A35W18	Cooling capacity	218	242	269	300	338	385	431	491	kW
	Power input	57,7	63,4	71,6	81,2	91,5	104	116	133	kW
	<b>EER</b>	<b>3,78</b>	<b>3,82</b>	<b>3,76</b>	<b>3,69</b>	<b>3,69</b>	<b>3,70</b>	<b>3,72</b>	<b>3,69</b>	W/W
	Water flow rate	10,52	11,7	13,0	14,5	16,3	18,6	20,8	23,7	l/s
	Pressure drops	64	60	62	64	64	59	60	54	kPa
IP	Base setting up (AB)	160.4	180.4	200.4	230.4	260.4	290.4	330.4	375.4	
A35W18	Cooling capacity	215	238	264	297	337	382	430	489	kW
	Power input	57,5	63,3	71,3	80,2	91,0	103	116	132	kW
	<b>EER</b>	<b>3,74</b>	<b>3,76</b>	<b>3,70</b>	<b>3,70</b>	<b>3,70</b>	<b>3,71</b>	<b>3,71</b>	<b>3,70</b>	W/W
	Water flow rate	10,36	11,5	12,7	14,3	16,3	18,4	20,7	23,5	l/s
	Pressure drops	62	58	59	62	64	57	59	53	kPa
A7W35	Heating capacity	187	209	233	258	298	337	375	428	kW
	Power input	47,1	53,4	59,4	66,4	76,9	86,1	95	110	kW
	<b>COP</b>	<b>3,97</b>	<b>3,91</b>	<b>3,92</b>	<b>3,89</b>	<b>3,88</b>	<b>3,91</b>	<b>3,95</b>	<b>3,89</b>	W/W
	Water flow rate	8,89	9,93	11,0	12,3	14,1	16,0	17,8	20,3	l/s
	Pressure drops	45	43	45	46	48	43	44	40	kPa

Data declared according to EN 14511. The values are referred to units without options and accessories.

**EER** (Energy Efficiency Ratio) = ratio of the total cooling capacity to the effective power input of the unit

**COP** (Coefficient Of Performance) = ratio of the total heating capacity to the effective power input of the unit

**ESEER** (European Seasonal Energy Efficiency Ratio) = Unit in **A CLASS**.

**A35W7** = source : air in 35°C d.b. / plant : water in 12°C out 7°C

**A35W18** = source : air in 35°C d.b. / plant : water in 23°C out 18°C

**A7W45** = source : air in 7°C d.b. 6°C w.b. / plant : water in 40°C out 45°C

**A7W35** = source : air in 7°C d.b. 6°C w.b. / plant : water in 30°C out 35°C

**Acoustic performances**

Base setting up (AB)	160.4	180.4	200.4	230.4	260.4	290.4	330.4	375.4	
Sound power level <sup>(E)</sup>	91	92	92	92	93	94	94	95	dB(A)
Sound pressure level at 1 meter	72	73	73	73	74	75	74	75	dB(A)
Sound pressure level at 5 meters	64	65	65	65	66	67	67	68	dB(A)
Sound pressure level at 10 meters	59	60	60	60	61	62	62	63	dB(A)
Low noise setting up (AS)	160.4	180.4	200.4	230.4	260.4	290.4	330.4	375.4	
Sound power level <sup>(E)</sup>	85	86	86	86	87	88	88	89	dB(A)
Sound pressure level at 1 meter	66	67	67	67	68	69	68	69	dB(A)
Sound pressure level at 5 meters	58	59	59	59	60	61	61	62	dB(A)
Sound pressure level at 10 meters	53	54	54	54	55	56	56	57	dB(A)
eXtra low noise setting up (AX)	160.4	180.4	200.4	230.4	260.4	290.4	330.4	375.4	
Sound power level <sup>(E)</sup>	82	83	83	83	84	85	85	86	dB(A)
Sound pressure level at 1 meter	63	64	64	64	65	66	65	66	dB(A)
Sound pressure level at 5 meters	55	56	56	56	57	58	58	59	dB(A)
Livello di pressione sonora a 10 metri	50	51	51	51	52	53	53	54	dB(A)

(E): EUROVENT certified data

The acoustic performances are referred to units operating in cooling mode at nominal conditions A35W7.

Unit placed in free field on reflecting surface (directional factor equal to 2).

The sound power level is measured according to ISO 9614 standard.

The sound pressure level is calculated according to ISO 3744 and is referred to a distance of 1/5/10 metres from the external surface of the unit.

**Technical data**

Unit	160.4	180.4	200.4	230.4	260.4	290.4	330.4	375.4	
Power supply	400 - 3 - 50								V-ph-Hz
Compressor type	scroll								-
N° compressors / N° refrigerant circuits	4 / 2								n°
Plant side heat exchanger type	stainless steel brazed plates								-
Source side heat exchanger type	finned coil								-
Fans type	axial								-
N° fans	4					6		8	n°
Tank volume	325				710				l
Hydraulic fittings	3" VICTAULIC				4" VICTAULIC				-

**Electrical data**

Standard unit	160.4	180.4	200.4	230.4	260.4	290.4	330.4	375.4	
<b>FLA</b> - Full load current at maximum tolerated conditions	140	151	177	193	217	243	269	314	A
<b>FLI</b> - Full load power input at maximum tolerated conditions	76	87	107	118	133	148	163	186	kW
<b>MIC</b> - Maximum instantaneous current of the unit	283	340	347	355	379	469	495	510	A
<b>MIC SS</b> - Maximum instantaneous current of the unit with soft starter options	213	250	263	271	295	354	380	404	A
Unit with high head modulating pump	160.4	180.4	200.4	230.4	260.4	290.4	330.4	375.4	
<b>FLA</b> - Full load current at maximum tolerated conditions	149	160	187	203	227	256	282	327	A
<b>FLI</b> - Full load power input at maximum tolerated conditions	81	91	113	124	139	156	171	194	kW
<b>MIC</b> - Maximum instantaneous current of the unit	292	348	357	365	389	482	508	524	A
<b>MIC SS</b> - Maximum instantaneous current of the unit with soft starter options	222	258	273	281	305	368	394	417	A

**Operative range**

Temperature	Unit type	Cooling		Heating		
		min	max	min	max	
Outdoor air inlet temperature	IR, BR, IP, BP	-10*	55**	-15	40*	(°C)
Water outlet temperature	IR, IP	5	25	30	55	(°C)
Water outlet temperature	BR, BP	-12	25	30	55	(°C)
Water outlet temperature (VD)	IR, BR, IP, BP	30	70	30	70	(°C)
Water outlet temperature (VR)	IR, BR	30	55	-	-	(°C)

\* with fans modulating control option (condensation / evaporation control)

\*\* with ATC outdoor high temperature protection function



## VD and VR versions

These units allow to recover the heating power, otherwise wasted on air, through an additional heat exchanger.

The **Desuperheater Version (VD)** allow the hot water production at temperatures between 30 and 70°C through the partial heat recovery of the condensation heat.

The **Total Recovery Version (VR)** allows the cold water production and, at the same time, the hot water production at temperatures between 30 and 55°C through the total recovery of the condensation heat.

### Desupeheater Version (VD) - NET NOMINAL performances

IR	Base setting up (AB)	160.4	180.4	200.4	230.4	260.4	290.4	330.4	375.4	
A35W7 - W45	Cooling capacity	177	197	218	244	275	312	350	398	kW
	Total power input	53,1	58,5	66,1	74,7	84,5	96	106	123	kW
	<b>EER</b>	<b>3,33</b>	<b>3,36</b>	<b>3,30</b>	<b>3,27</b>	<b>3,25</b>	<b>3,24</b>	<b>3,29</b>	<b>3,22</b>	<b>W/W</b>
	<b>HRE</b>	<b>4,18</b>	<b>4,22</b>	<b>4,17</b>	<b>4,15</b>	<b>4,10</b>	<b>4,11</b>	<b>4,17</b>	<b>4,09</b>	<b>W/W</b>
	Water flow rate	8,55	9,49	10,5	11,8	13,3	15,1	16,9	19,2	l/s
	Water pressure drop	62	63	69	66	71	74	63	68	kPa
	Heating recovery capacity	45,0	50,3	57,6	66,2	72,0	83,4	94,0	107	kW
	Water flow rate recovery	2,15	2,40	2,75	3,16	3,44	3,98	4,49	5,11	l/s
	Water pressure drop recovery	5	6	8	10	12	16	20	26	kPa
	IP	Base setting up (AB)	160.4	180.4	200.4	230.4	260.4	290.4	330.4	375.4
A35W7 - W45	Cooling capacity	174	193	214	241	274	309	349	396	kW
	Total power input	53,0	58,4	65,9	73,8	84,1	95	106	122	kW
	<b>EER</b>	<b>3,29</b>	<b>3,31</b>	<b>3,25</b>	<b>3,26</b>	<b>3,25</b>	<b>3,25</b>	<b>3,28</b>	<b>3,23</b>	<b>W/W</b>
	<b>HRE</b>	<b>4,14</b>	<b>4,17</b>	<b>4,12</b>	<b>4,15</b>	<b>4,11</b>	<b>4,12</b>	<b>4,16</b>	<b>4,10</b>	<b>W/W</b>
	Water flow rate	8,42	9,31	10,34	11,6	13,2	15,0	16,8	19,1	l/s
	Water pressure drop	60	61	67	64	70	73	62	67	kPa
	Heating recovery capacity	45,0	50,3	57,5	65,4	71,6	82,3	94,0	106	kW
	Water flow rate recovery	2,15	2,40	2,75	3,12	3,42	3,93	4,49	5,06	l/s
	Water pressure drop recovery	5	6	8	10	12	16	20	26	kPa

### Total Recovery Version (VR) - NET NOMINAL performances

IR	Base setting up (AB)	160.4	180.4	200.4	230.4	260.4	290.4	330.4	375.4	
A35W7 - W45	Cooling capacity	179	198	220	246	277	315	353	402	kW
	Total power input	45,5	50,8	58,4	66,9	73,1	84,8	95	108	kW
	<b>EER</b>	<b>3,93</b>	<b>3,91</b>	<b>3,77</b>	<b>3,68</b>	<b>3,79</b>	<b>3,72</b>	<b>3,72</b>	<b>3,72</b>	<b>W/W</b>
	<b>HRE</b>	<b>8,81</b>	<b>8,77</b>	<b>8,50</b>	<b>8,32</b>	<b>8,54</b>	<b>8,39</b>	<b>8,40</b>	<b>8,38</b>	<b>W/W</b>
	Water flow rate	8,63	9,58	10,6	11,9	13,4	15,3	17,1	19,4	l/s
	Water pressure drop	64	64	70	67	72	76	65	69	kPa
	Heating recovery capacity	222	247	276	310	347	396	444	505	kW
	Water flow rate recovery	10,6	11,8	13,2	14,8	16,6	18,9	21,2	24,1	l/s
	Water pressure drop recovery	49	47	48	47	49	51	51	53	kPa

Data declared according to **EN 14511**. The values are referred to units without options and accessories.

**EER** (Energy Efficiency Ratio) = ratio of the total cooling capacity to the effective power input of the unit

**HRE** (Heat Recovery Efficiency) = ratio of the total capacity of the system (heating plus cooling capacity) to the effective power input

**A35W7 - W45** = source : air in 35°C d.b. / plant : water in 12°C out 7°C / Recovery : water in 40°C out 45°C

## CONTROL SYSTEM

The units are equipped with a controller designed to ensure energy saving and unit efficiency. Available functions :

- ATC outdoor high temperature protection function
- Dynamic defrost
- Sound management
- Climatic control in heating and in cooling mode
- Double set point function
- Demand limit
- Integrative heating
- Remote stand by
- Remote cooling-heating



## DIMENSIONS - MINIMUM OPERATING AREA - WEIGHT

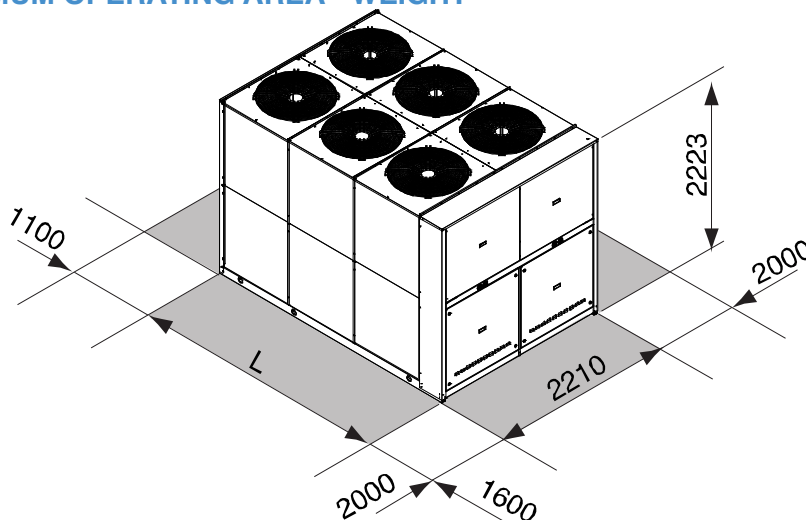

	160.4	180.4	200.4	230.4	260.4	290.4	330.4	375.4	
L	3164	3164	3164	3164	3164	4097	4097	4097	mm
Operating maximum weight*	2441	2633	2829	3005	3069	3690	3790	3907	kg

\* Weight refers to the unit IP with tank and pumping module 2 pumps.

# > RHA

## AIR-WATER CHILLERS AND HEAT PUMPS FOR OUTDOOR INSTALLATION



### Available range

#### Unit type

IR	Chiller
IP	Heat pump (reversible on the refrigerant side)
BR	Chiller Brine
BP	Heat pump Brine (reversible on the refrigerant side)

#### Version

VB	Base version
VD	Desuperheater version
VR	Total recovery version

#### Acoustic setting up

AB	Base setting up
AS	Low noise setting up
AX	eXtra low noise setting up

#### Source temperature level

M	Medium temperature level
A	High temperature level

### Unit description

This series of air-water chillers and heat pumps satisfies the cooling and heating requirements of residential plants of large size.

All the units are suitable for outdoor installation and can be applied to fan coil plants, radiant floor plants and high efficiency radiators plants.

The refrigerant circuit, contained in a compartment protected from the air flow to simplify the maintenance operations, is equipped with scroll compressors mounted on damper supports, brazed plate heat exchanger, electronic expan-

sion valve, reverse cycle valve, dehydrator filter, axial fans with safety protection grilles, finned coil made of copper pipes and aluminium louvered fins. The circuit is protected by a safety gas valve, high and low pressure switches and differential pressure switch on the plate heat exchanger.

The plate heat exchanger and all the hydraulic pipes are thermally insulated in order to avoid condensate generation and to reduce thermal losses.

All the units can be equipped with variable speed fans control that allows the units to operate with low outdoor temperatures in cooling and high outdoor temperature in heating and permits to reduce noise emissions in such operating conditions.

The low noise acoustic setting up (AS) is obtained, starting from the base setting up (AB), reducing the rotational speed of the fans and mounting sound jackets on the compressors and the technical compartment is clad with soundproofing material of suitable thickness.

The eXtra low noise acoustic setting up (AX) is obtained, starting from the low noise setting up (AS), further reducing the rotational speed of the fans and using finned coil with bigger surface.

All the units are supplied with a management and control electrical panel containing general switch, phase presence and correct sequence controller, microprocessor controller with display and all the other electrical components with IP54 minimum protection degree.

All the units are accurately built and individually tested in the factory. Only electric and hydraulic connections are required for installation.

### Options

**Storing and pumping module** available in the configurations :

- storage tank arranged as buffer on the flow or as primary-secondary buffer
- 1 or 2 pumps
- standard or high head pump

**Refrigerant circuit pressures visualization**

- high and low pressure gauges
- high and low pressure transducers

**High temperature thermostat**

**Compressor starting**

- standard (contactors)
- soft starter

**Fans control**

- on-off control
- modulating control (condensation / evaporation control) standard for AS and AX unit

**Compressor power factor correction**

**Electrical load protection**

- fuses
- thermal magnetic circuit breakers

**Coil condensate tray**

### Accessories

**Rubber vibration dampers**

**Spring vibration dampers**

**Coil protection grilles**

**Tank antifreeze electrical heater**

**Remote control**

**Modbus serial interface on RS485**

**Programmer clock**

**Phase sequence and voltage controller**

**Water flow switch**

**Victaulic hydraulic fittings**

**NET NOMINAL performances - Standard plants - EUROVENT certified data**

IR	Base setting up (AB)	350.5	390.6	440.6	490.6	560.6	630.6	
A35W7	Cooling capacity	348	371	436	489	554	619	kW
	Power input	123	131	152	174	193	219	kW
	EER	2,83	2,83	2,87	2,81	2,87	2,83	W/W
	ESEER	3,90	3,90	3,93	3,90	3,94	3,91	W/W
	Water flow rate	16,8	17,9	21,0	23,6	26,7	29,9	l/s
	Pressure drops	47	54	48	60	45	56	kPa
IR	Low noise setting up (AS)	350.5	390.6	440.6	490.6	560.6	630.6	
A35W7	Cooling capacity	335	356	418	470	532	595	kW
	Power input	129	140	162	185	207	233	kW
	EER	2,60	2,54	2,58	2,54	2,57	2,55	W/W
	ESEER	3,78	3,74	3,77	3,74	3,76	3,75	W/W
	Water flow rate	16,1	17,2	20,1	22,6	25,6	28,7	l/s
	Pressure drops	43	50	44	55	41	52	kPa
IR	eXtra low noise setting up (AX)	350.5	390.6	440.6	490.6	560.6	630.6	
A35W7	Cooling capacity	328	349	410	460	522	583	kW
	Power input	133	144	166	190	211	239	kW
	EER	2,47	2,42	2,47	2,42	2,47	2,44	W/W
	ESEER	3,87	3,84	3,89	3,84	3,88	3,86	W/W
	Water flow rate	15,8	16,8	19,7	22,2	25,1	28,1	l/s
	Pressure drops	42	47	42	53	40	49	kPa
IP	Base setting up (AB)	350.5	390.6	440.6	490.6	560.6	630.6	
A35W7	Cooling capacity	339	361	423	476	536	603	kW
	Power input	120	130	151	171	191	216	kW
	EER	2,83	2,78	2,80	2,78	2,81	2,79	W/W
	ESEER	3,85	3,83	3,84	3,84	3,85	3,85	W/W
	Water flow rate	16,3	17,4	20,4	22,9	25,8	29,0	l/s
	Pressure drops	45	51	45	57	42	53	kPa
A7W45	Heating capacity	373	397	460	521	580	664	kW
	Power input	123	132	152	174	192	223	kW
	COP	3,03	3,01	3,03	2,99	3,02	2,98	W/W
	Water flow rate	17,7	18,8	21,8	24,7	27,5	31,4	l/s
Pressure drops	53	59	51	66	48	62	kPa	
IP	Low noise setting up (AS)	350.5	390.6	440.6	490.6	560.6	630.6	
A35W7	Cooling capacity	325	346	406	457	515	579	kW
	Power input	128	138	161	183	204	231	kW
	EER	2,54	2,51	2,52	2,50	2,52	2,51	W/W
	ESEER	3,70	3,69	3,69	3,67	3,67	3,69	W/W
	Water flow rate	15,6	16,7	19,5	22,0	24,7	27,9	l/s
	Pressure drops	41	47	41	52	38	49	kPa
A7W45	Heating capacity	358	380	441	500	557	638	kW
	Power input	118	125	145	166	184	213	kW
	COP	3,03	3,04	3,04	3,01	3,03	3,00	W/W
	Water flow rate	17,0	18,0	20,9	23,7	26,4	30,2	l/s
Pressure drops	48	54	47	61	44	57	kPa	
IP	eXtra low noise setting up (AX)	350.5	390.6	440.6	490.6	560.6	630.6	
A35W7	Cooling capacity	319	340	397	447	505	568	kW
	Power input	131	140	165	187	209	236	kW
	EER	2,44	2,43	2,41	2,39	2,42	2,41	W/W
	ESEER	3,83	3,81	3,79	3,79	3,79	3,79	W/W
	Water flow rate	15,3	16,3	19,1	21,5	24,3	27,3	l/s
	Pressure drops	39	45	39	50	37	47	kPa
A7W45	Heating capacity	355	376	436	495	551	631	kW
	Power input	116	123	142	163	180	209	kW
	COP	3,06	3,06	3,07	3,04	3,06	3,02	W/W
	Water flow rate	16,8	17,8	20,7	23,4	26,1	29,9	l/s
Pressure drops	47	53	46	59	43	56	kPa	

**NET NOMINAL performances - Radiant plants**

IR	Base setting up (AB)	350.5	390.6	440.6	490.6	560.6	630.6	
A35W18	Cooling capacity	444	472	555	622	706	788	kW
	Power input	131	142	164	188	208	236	kW
	EER	3,39	3,32	3,38	3,31	3,39	3,34	W/W
	Water flow rate	21,5	22,9	26,8	30,2	34,1	38,2	l/s
	Pressure drops	77	88	78	98	73	91	kPa
	IP	Base setting up (AB)	350.5	390.6	440.6	490.6	560.6	630.6
A35W18	Cooling capacity	431	460	539	605	684	767	kW
	Power input	130	139	162	185	205	233	kW
	EER	3,32	3,31	3,33	3,27	3,34	3,29	W/W
	Water flow rate	20,9	22,3	26,1	29,4	33,0	37,2	l/s
	Pressure drops	73	83	74	93	68	87	kPa
	A7W35	Heating capacity	378	402	466	528	588	673
Power input		103	110	127	146	160	186	kW
COP		3,67	3,65	3,67	3,62	3,68	3,62	W/W
Water flow rate		17,9	19,0	22,1	25,0	27,9	31,8	l/s
Pressure drops	54	61	53	67	49	63	kPa	

Data declared according to EN 14511. The values are referred to units without options and accessories.

**EER** (Energy Efficiency Ratio) = ratio of the total cooling capacity to the effective power input of the unit

**COP** (Coefficient Of Performance) = ratio of the total heating capacity to the effective power input of the unit

**ESEER** (European Seasonal Energy Efficiency Ratio)

= Unit in **A CLASS**.

**A35W7** = source : air in 35°C d.b. / plant : water in 12°C out 7°C

**A35W18** = source : air in 35°C d.b. / plant : water in 23°C out 18°C

**A7W45** = source : air in 7°C d.b. 6°C w.b. / plant : water in 40°C out 45°C

**A7W35** = source : air in 7°C d.b. 6°C w.b. / plant : water in 30°C out 35°C



### Acoustic performances

Base setting up (AB)	350.5	390.6	440.6	490.6	560.6	630.6	
Sound power level <sup>(E)</sup>	95	95	96	96	97	97	dB(A)
Sound pressure level at 1 meter	75	75	76	76	76	76	dB(A)
Sound pressure level at 5 meters	67	67	68	68	69	69	dB(A)
Sound pressure level at 10 meters	63	63	64	64	65	65	dB(A)
Low noise setting up (AS)	350.5	390.6	440.6	490.6	560.6	630.6	
Sound power level <sup>(E)</sup>	89	89	90	90	91	91	dB(A)
Sound pressure level at 1 meter	69	69	70	70	70	70	dB(A)
Sound pressure level at 5 meters	61	61	62	62	63	63	dB(A)
Sound pressure level at 10 meters	57	57	58	58	59	59	dB(A)
eXtra low noise setting up (AX)	350.5	390.6	440.6	490.6	560.6	630.6	
Sound power level <sup>(E)</sup>	86	86	87	87	88	88	dB(A)
Sound pressure level at 1 meter	66	66	67	67	67	67	dB(A)
Sound pressure level at 5 meters	58	58	59	59	60	60	dB(A)
Sound pressure level at 10 meters	54	54	55	55	56	56	dB(A)

(E): EUROVENT certified data

The acoustic performances are referred to units operating in cooling mode at nominal conditions A35W7.

Unit placed in free field on reflecting surface (directional factor equal to 2).

The sound power level is measured according to ISO 9614 standard.

The sound pressure level is calculated according to ISO 3744 and is referred to a distance of 1/5/10 metres from the external surface of the unit.

### Technical data

Unit	350.5	390.6	440.6	490.6	560.6	630.6	
Power supply	400 - 3 - 50						V-ph-Hz
Compressor type	scroll						-
N° compressors / N° refrigerant circuits	5 / 2	6 / 2					n°
Plant side heat exchanger type	stainless steel brazed plates						-
Source side heat exchanger type	finned coil						-
Fans type	axial						-
N° fans	8	10		12			n°
Tank volume	700						l
Hydraulic fittings	4" VICTAULIC						-

### Electrical data

Standard unit	350.5	390.6	440.6	490.6	560.6	630.6	
<b>FLA</b> - Full load current at maximum tolerated conditions	287	302	355	399	451	494	A
<b>FLI</b> - Full load power input at maximum tolerated conditions	171	182	211	237	272	304	kW
<b>MIC</b> - Maximum instantaneous current of the unit	538	529	605	649	771	815	A
<b>MIC SS</b> - Maximum instantaneous current of the unit with soft starter options	434	441	508	552	640	684	A
Unit with high head modulating pump	350.5	390.6	440.6	490.6	560.6	630.6	
<b>FLA</b> - Full load current at maximum tolerated conditions	308	323	382	426	478	521	A
<b>FLI</b> - Full load power input at maximum tolerated conditions	184	195	227	253	288	320	kW
<b>MIC</b> - Maximum instantaneous current of the unit	558	550	632	676	798	842	A
<b>MIC SS</b> - Maximum instantaneous current of the unit with soft starter options	558	550	632	676	798	842	A

### Operative range

Temperature	Unit type	Cooling		Heating		
		min	max	min	max	
Outdoor air inlet temperature	IR, BR, IP, BP	-10*	55**	-10	40*	(°C)
Water outlet temperature	IR, IP	5	25	30	55	(°C)
Water outlet temperature	BR, BP	-12	25	30	55	(°C)
Water outlet temperature (VD)	IR, BR, IP, BP	30	70	30	70	(°C)
Water outlet temperature (VR)	IR, BR	30	55	-	-	(°C)

\* with fans modulating control option (condensation / evaporation control)

\*\* with ATC outdoor high temperature protection function

## VD and VR versions

These units allow to recover the heating power, otherwise wasted on air, through an additional heat exchanger.

The **Desuperheater Version (VD)** allow the hot water production at temperatures between 30 and 70°C through the partial heat recovery of the condensation heat.

The **Total Recovery Version (VR)** allows the cold water production and, at the same time, the hot water production at temperatures between 30 and 55°C through the total recovery of the condensation heat.

### Desupeheater Version (VD) - NET NOMINAL performances

IR	Base setting up (AB)	350.5	390.6	440.6	490.6	560.6	630.6	
A35W7 - W45	Cooling capacity	362	385	453	509	576	644	kW
	Total power input	120	129	150	170	189	213	kW
	<b>EER</b>	<b>3,02</b>	<b>3</b>	<b>3,03</b>	<b>2,99</b>	<b>3,06</b>	<b>3,02</b>	<b>W/W</b>
	<b>HRE</b>	<b>3,75</b>	<b>3,72</b>	<b>3,76</b>	<b>3,71</b>	<b>3,79</b>	<b>3,75</b>	<b>W/W</b>
	Water flow rate	17,5	18,6	21,8	24,6	27,8	31,0	l/s
	Water pressure drop	51	58	51	65	49	60	kPa
	Heating recovery capacity	87,7	93,4	110	123	139	156	kW
	Water flow rate recovery	4,19	4,46	5,26	5,88	6,64	7,45	l/s
	Water pressure drop recovery	24	27	25	32	31	39	kPa
	IP	Base setting up (AB)	350.5	390.6	440.6	490.6	560.6	630.6
A35W7 - W45	Cooling capacity	352	376	440	494	558	626	kW
	Total power input	118	126	147	168	187	211	kW
	<b>EER</b>	<b>2,99</b>	<b>2,97</b>	<b>2,98</b>	<b>2,94</b>	<b>2,98</b>	<b>2,97</b>	<b>W/W</b>
	<b>HRE</b>	<b>3,72</b>	<b>3,69</b>	<b>3,7</b>	<b>3,66</b>	<b>3,71</b>	<b>3,69</b>	<b>W/W</b>
	Water flow rate	16,9	18,1	21,2	23,9	26,8	30,2	l/s
	Water pressure drop	48	55	49	62	45	57	kPa
	Heating recovery capacity	85,2	90,7	106	120	135	152	kW
	Water flow rate recovery	4,07	4,33	5,06	5,73	6,45	7,26	l/s
	Water pressure drop recovery	23	26	24	30	29	36	kPa

### Total Recovery Version (VR) - NET NOMINAL performances

IR	Base setting up (AB)	350.5	390.6	440.6	490.6	560.6	630.6	
A35W7 - W45	Cooling capacity	362	385	453	509	576	644	kW
	Total power input	104	113	130	150	166	190	kW
	<b>EER</b>	<b>3,48</b>	<b>3,42</b>	<b>3,49</b>	<b>3,38</b>	<b>3,48</b>	<b>3,38</b>	<b>W/W</b>
	<b>HRE</b>	<b>7,92</b>	<b>7,8</b>	<b>7,94</b>	<b>7,72</b>	<b>7,92</b>	<b>7,72</b>	<b>W/W</b>
	Water flow rate	17,5	18,6	21,8	24,6	27,8	31,0	l/s
	Water pressure drop	51	58	51	65	49	60	kPa
	Heating recovery capacity	461	493	577	652	734	824	kW
	Water flow rate recovery	22	23,6	27,6	31,2	35,1	39,4	l/s
	Water pressure drop recovery	52	60	51	66	54	68	kPa

Data declared according to **EN 14511**. The values are referred to units without options and accessories.

**EER** (Energy Efficiency Ratio) = ratio of the total cooling capacity to the effective power input of the unit

**HRE** (Heat Recovery Efficiency) = ratio of the total capacity of the system (heating plus cooling capacity) to the effective power input

**A35W7 - W45** = source : air in 35°C d.b. / plant : water in 12°C out 7°C / Recovery : water in 40°C out 45°C

## CONTROL SYSTEM

The units are equipped with a controller designed to ensure energy saving and unit efficiency. Available functions :

- ATC outdoor high temperature protection function
- Dynamic defrost
- Sound management
- Climatic control in heating and in cooling mode
- Double set point function
- Demand limit
- Integrative heating
- Remote stand by
- Remote cooling-heating



## DIMENSIONS - MINIMUM OPERATING AREA - WEIGHT

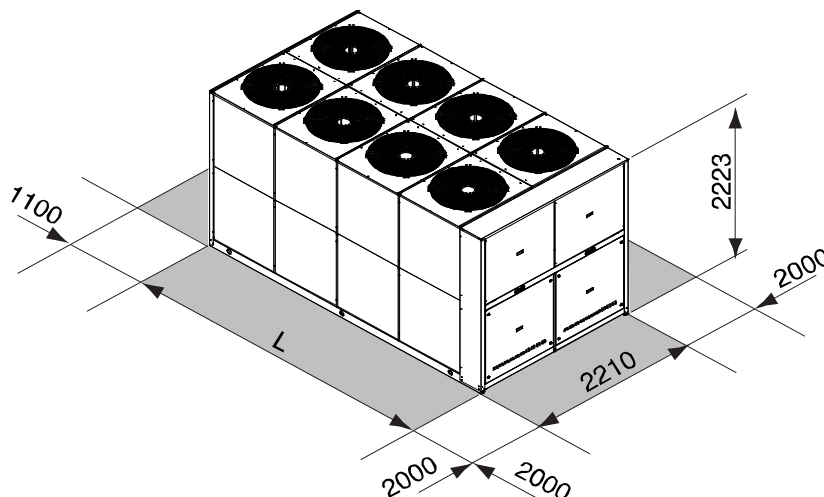

	350.5	390.6	440.6	490.6	560.6	630.6	
L	5030	5030	5030	5030	5963	5963	mm
Operating maximum weight*	4849	5058	5120	5199	5489	5568	kg

\* Weight refers to the unit IP with tank and pumping module 2 pumps.

# > RHA HE

## AIR-WATER CHILLERS AND HEAT PUMPS FOR OUTDOOR INSTALLATION



### Available range

#### Unit type

IR	Chiller
IP	Heat pump (reversible on the refrigerant side)
BR	Chiller Brine
BP	Heat pump Brine (reversible on the refrigerant side)

#### Version

VB	Base version
VD	Desuperheater version
VR	Total recovery version

#### Acoustic setting up

AB	Base setting up
AS	Low noise setting up
AX	eXtra low noise setting up

#### Source temperature level

M	Medium temperature level
A	High temperature level

### Unit description

This series of air-water chillers and heat pumps satisfies the cooling and heating requirements of residential plants of large size.

All the units are suitable for outdoor installation and can be applied to fan coil plants, radiant floor plants and high efficiency radiators plants.

The refrigerant circuit, contained in a compartment protected from the air flow to simplify the maintenance operations, is equipped with scroll compressors mounted on damper supports, brazed plate heat exchanger, electronic expan-

sion valve, reverse cycle valve, dehydrator filter, axial fans with safety protection grilles, finned coil made of copper pipes and aluminium louvered fins. The circuit is protected by a safety gas valve, high and low pressure switches and differential pressure switch on the plate heat exchanger.

The plate heat exchanger and all the hydraulic pipes are thermally insulated in order to avoid condensate generation and to reduce thermal losses.

All the units can be equipped with variable speed fans control that allows the units to operate with low outdoor temperatures in cooling and high outdoor temperature in heating and permits to reduce noise emissions in such operating conditions.

The low noise acoustic setting up (AS) is obtained, starting from the base setting up (AB), reducing the rotational speed of the fans and mounting sound jackets on the compressors and the technical compartment is clad with soundproofing material of suitable thickness.

The eXtra low noise acoustic setting up (AX) is obtained, starting from the low noise setting up (AS), further reducing the rotational speed of the fans and using finned coil with bigger surface.

All the units are supplied with a management and control electrical panel containing general switch, phase presence and correct sequence controller, microprocessor controller with display and all the other electrical components with IP54 minimum protection degree.

All the units are accurately built and individually tested in the factory. Only electric and hydraulic connections are required for installation.

### Options

[Storing and pumping module](#) available in the configurations :

- storage tank arranged as buffer on the flow or as primary-secondary buffer
- 1 or 2 pumps
- standard or high head pump

[Refrigerant circuit pressures visualization](#)

- high and low pressure gauges
- high and low pressure transducers

[High temperature thermostat](#)

[Compressor starting](#)

- standard (contactors)
- soft starter

[Fans control](#)

- on-off control
- modulating control (condensation / evaporation control) standard for AS and AX unit

[Compressor power factor correction](#)

[Electrical load protection](#)

- fuses
  - thermal magnetic circuit breakers
- [Coil condensate tray](#)

### Accessories

[Rubber vibration dampers](#)

[Spring vibration dampers](#)

[Coil protection grilles](#)

[Tank antifreeze electrical heater](#)

[Remote control](#)

[Modbus serial interface on RS485](#)

[Programmer clock](#)

[Phase sequence and voltage controller](#)

[Water flow switch](#)

[Viciaulic hydraulic fittings](#)



**NET NOMINAL performances - Standard plants - EUROVENT certified data**

IR	Base setting up (AB)	350.5	390.6	440.6	490.6	
A35W7	Cooling capacity	371	398	457	512	kW
	Power input	118	127	146	163	kW
	EER	3,14	3,13	3,13	3,14	W/W
	ESEER	4,27	4,29	4,25	4,29	W/W
	Water flow rate	17,8	19,1	21,9	24,6	l/s
	Pressure drops	33	38	29	37	kPa
IR	Low noise setting up (AS)	350.5	390.6	440.6	490.6	
A35W7	Cooling capacity	356	382	439	491	kW
	Power input	125	134	154	172	kW
	EER	2,85	2,85	2,85	2,85	W/W
	ESEER	4,15	4,15	4,13	4,16	W/W
	Water flow rate	17,1	18,3	21,1	23,6	l/s
	Pressure drops	31	35	27	34	kPa
IR	eXtra low noise setting up (AX)	350.5	390.6	440.6	490.6	
A35W7	Cooling capacity	349	374	429	482	kW
	Power input	126	136	156	175	kW
	EER	2,77	2,75	2,75	2,75	W/W
	ESEER	4,33	4,33	4,29	4,31	W/W
	Water flow rate	16,8	18,0	20,6	23,1	l/s
	Pressure drops	30	34	26	32	kPa
IP	Base setting up (AB)	350.5	390.6	440.6	490.6	
A35W7	Cooling capacity	365	392	448	497	kW
	Power input	117	126	144	160	kW
	EER	3,12	3,11	3,11	3,11	W/W
	ESEER	4,24	4,26	4,23	4,25	W/W
	Water flow rate	17,5	18,8	21,5	23,9	l/s
	Pressure drops	32	37	28	35	kPa
A7W45	Heating capacity	387	417	475	534	kW
	Power input	120	129	147	165	kW
	COP	3,23	3,23	3,23	3,24	W/W
	Water flow rate	18,4	19,8	22,6	25,4	l/s
Pressure drops	36	41	31	39	kPa	
IP	Low noise setting up (AS)	350.5	390.6	440.6	490.6	
A35W7	Cooling capacity	350	376	430	478	kW
	Power input	124	133	152	169	kW
	EER	2,82	2,83	2,83	2,83	W/W
	ESEER	4,12	4,12	4,10	4,12	W/W
	Water flow rate	16,8	18,1	20,6	22,9	l/s
	Pressure drops	30	34	26	32	kPa
A7W45	Heating capacity	372	399	456	513	kW
	Power input	113	121	139	156	kW
	COP	3,29	3,30	3,28	3,29	W/W
	Water flow rate	17,7	19,0	21,7	24,4	l/s
Pressure drops	33	38	28	36	kPa	
IP	eXtra low noise setting up (AX)	350.5	390.6	440.6	490.6	
A35W7	Cooling capacity	343	368	421	468	kW
	Power input	125	134	154	171	kW
	EER	2,74	2,74	2,73	2,74	W/W
	ESEER	4,29	4,29	4,26	4,29	W/W
	Water flow rate	16,5	17,7	20,2	22,5	l/s
	Pressure drops	29	33	25	31	kPa
A7W45	Heating capacity	368	395	451	507	kW
	Power input	109	118	134	151	kW
	COP	3,38	3,35	3,37	3,36	W/W
	Water flow rate	17,5	18,8	21,5	24,1	l/s
Pressure drops	32	37	28	35	kPa	

**NET NOMINAL performances - Radiant plants**

IR	Base setting up (AB)	350.5	390.6	440.6	490.6	560.6	630.6	
A35W18	Cooling capacity	473	507	583	653	746	833	kW
	Power input	127	136	156	175	200	222	kW
	EER	3,72	3,73	3,74	3,73	3,73	3,75	W/W
	Water flow rate	22,8	24,5	28,1	31,5	36,0	40,4	l/s
	Pressure drops	55	63	48	60	70	86	kPa
	IP	Base setting up (AB)	350.5	390.6	440.6	490.6	560.6	630.6
A35W18	Cooling capacity	466	499	572	634	731	816	kW
	Power input	125	135	154	171	197	220	kW
	EER	3,73	3,70	3,71	3,71	3,71	3,71	W/W
	Water flow rate	22,4	24,1	27,5	30,6	35,3	39,5	l/s
	Pressure drops	53	61	46	57	67	83	kPa
	A7W35	Heating capacity	377	400	464	526	587	672
Power input		102	109	125	143	160	185	kW
COP		3,70	3,67	3,71	3,68	3,67	3,63	W/W
Water flow rate		17,9	19,0	22,1	25,0	27,9	31,8	l/s
Pressure drops	34	38	29	38	42	54	kPa	

Data declared according to EN 14511. The values are referred to units without options and accessories.

**EER** (Energy Efficiency Ratio) = ratio of the total cooling capacity to the effective power input of the unit

**COP** (Coefficient Of Performance) = ratio of the total heating capacity to the effective power input of the unit

**ESEER** (European Seasonal Energy Efficiency Ratio)

= Unit in **A CLASS**.

**A35W7** = source : air in 35°C d.b. / plant : water in 12°C out 7°C

**A35W18** = source : air in 35°C d.b. / plant : water in 23°C out 18°C

**A7W45** = source : air in 7°C d.b. 6°C w.b. / plant : water in 40°C out 45°C

**A7W35** = source : air in 7°C d.b. 6°C w.b. / plant : water in 30°C out 35°C

**Acoustic performances**

Base setting up (AB)	350.5	390.6	440.6	490.6	
Sound power level <sup>(E)</sup>	95	95	96	96	dB(A)
Sound pressure level at 1 meter	75	75	76	76	dB(A)
Sound pressure level at 5 meters	67	67	68	68	dB(A)
Sound pressure level at 10 meters	63	63	64	64	dB(A)
Low noise setting up (AS)	350.5	390.6	440.6	490.6	
Sound power level <sup>(E)</sup>	89	89	90	90	dB(A)
Sound pressure level at 1 meter	69	69	70	70	dB(A)
Sound pressure level at 5 meters	61	61	62	62	dB(A)
Sound pressure level at 10 meters	57	57	58	58	dB(A)
eXtra low noise setting up (AX)	350.5	390.6	440.6	490.6	
Sound power level <sup>(E)</sup>	86	86	87	87	dB(A)
Sound pressure level at 1 meter	66	66	67	67	dB(A)
Sound pressure level at 5 meters	58	58	59	59	dB(A)
Sound pressure level at 10 meters	54	54	55	55	dB(A)

**(E): EUROVENT** certified data

The acoustic performances are referred to units operating in cooling mode at nominal conditions A35W7.

Unit placed in free field on reflecting surface (directional factor equal to 2).

The sound power level is measured according to ISO 9614 standard.

The sound pressure level is calculated according to ISO 3744 and is referred to a distance of 1/5/10 metres from the external surface of the unit.

**Technical data**

Unit	350.5	390.6	440.6	490.6	
Power supply	400 - 3 - 50				V-ph-Hz
Compressor type	scroll				-
N° compressors / N° refrigerant circuits	5 / 2	6 / 2			n°
Plant side heat exchanger type	stainless steel brazed plates				-
Source side heat exchanger type	finned coil				-
Fans type	axial				-
N° fans	8	10			n°
Tank volume	700				l
Hydraulic fittings	4" VICTAULIC				-

**Electrical data**

Standard unit	350.5	390.6	440.6	490.6	
<b>FLA</b> - Full load current at maximum tolerated conditions	171	182	211	237	A
<b>FLI</b> - Full load power input at maximum tolerated conditions	287	302	355	399	kW
<b>MIC</b> - Maximum instantaneous current of the unit	538	529	605	649	A
<b>MIC SS</b> - Maximum instantaneous current of the unit with soft starter options	414	421	481	525	A
Unit with high head modulating pump	350.5	390.6	440.6	490.6	
<b>FLA</b> - Full load current at maximum tolerated conditions	184	195	227	253	A
<b>FLI</b> - Full load power input at maximum tolerated conditions	308	323	382	426	kW
<b>MIC</b> - Maximum instantaneous current of the unit	558	550	632	676	A
<b>MIC SS</b> - Maximum instantaneous current of the unit with soft starter options	434	441	508	552	A

**Operative range**

Temperature	Unit type	Cooling		Heating		
		min	max	min	max	
Outdoor air inlet temperature	IR, BR, IP, BP	-10*	55**	-10	40*	(°C)
Water outlet temperature	IR, IP	5	25	30	55	(°C)
Water outlet temperature	BR, BP	-12	25	30	55	(°C)
Water outlet temperature (VD)	IR, BR, IP, BP	30	70	30	70	(°C)
Water outlet temperature (VR)	IR, BR	30	55	-	-	(°C)

\* with fans modulating control option (condensation / evaporation control)

\*\* with ATC outdoor high temperature protection function

## VD and VR versions

These units allow to recover the heating power, otherwise wasted on air, through an additional heat exchanger.

The **Desuperheater Version (VD)** allow the hot water production at temperatures between 30 and 70°C through the partial heat recovery of the condensation heat.

The **Total Recovery Version (VR)** allows the cold water production and, at the same time, the hot water production at temperatures between 30 and 55°C through the total recovery of the condensation heat.

### Desupeheater Version (VD) - NET NOMINAL performances

IR	Base setting up (AB)	350.5	390.6	440.6	490.6	
A35W7 - W45	Cooling capacity	386	413	475	532	kW
	Total power input	115,6	123,8	142,6	159,1	kW
	<b>EER</b>	<b>3,34</b>	<b>3,34</b>	<b>3,33</b>	<b>3,34</b>	<b>W/W</b>
	<b>HRE</b>	<b>4,21</b>	<b>4,22</b>	<b>4,21</b>	<b>4,23</b>	<b>W/W</b>
	Water flow rate	18,5	19,9	22,8	25,6	l/s
	Water pressure drop	36	41	31	40	kPa
	Heating recovery capacity	101	109	125	140	kW
	Water flow rate recovery	4,82	5,20	5,96	6,71	l/s
	Water pressure drop recovery	24	27	25	32	kPa
	IP	Base setting up (AB)	350.5	390.6	440.6	490.6
A35W7 - W45	Cooling capacity	380	407	466	517	kW
	Total power input	114,5	122,7	140,5	155,9	kW
	<b>EER</b>	<b>3,32</b>	<b>3,32</b>	<b>3,31</b>	<b>3,32</b>	<b>W/W</b>
	<b>HRE</b>	<b>4,12</b>	<b>4,12</b>	<b>4,11</b>	<b>4,12</b>	<b>W/W</b>
	Water flow rate	18,2	19,6	22,4	24,8	l/s
	Water pressure drop	35	40	30	37	kPa
	Heating recovery capacity	92	98	112	125	kW
	Water flow rate recovery	4,38	4,70	5,35	5,97	l/s
	Water pressure drop recovery	20	22	20	25	kPa

### Total Recovery Version (VR) - NET NOMINAL performances

IR	Base setting up (AB)	350.5	390.6	440.6	490.6	
A35W7 - W45	Cooling capacity	386	413	475	532	kW
	Total power input	100	108	123	140	kW
	<b>EER</b>	<b>3,85</b>	<b>3,81</b>	<b>3,85</b>	<b>3,81</b>	<b>W/W</b>
	<b>HRE</b>	<b>8,65</b>	<b>8,58</b>	<b>8,65</b>	<b>8,57</b>	<b>W/W</b>
	Water flow rate	18,50	19,9	22,8	25,6	l/s
	Water pressure drop	36	41	31	40	kPa
	Heating recovery capacity	481	516	592	665	kW
	Water flow rate recovery	23,0	24,7	28,3	31,8	l/s
	Water pressure drop recovery	52	59	48	61	kPa

Data declared according to EN 14511. The values are referred to units without options and accessories.

**EER** (Energy Efficiency Ratio) = ratio of the total cooling capacity to the effective power input of the unit

**HRE** (Heat Recovery Efficiency) = ratio of the total capacity of the system (heating plus cooling capacity) to the effective power input

**A35W7 - W45** = source : air in 35°C d.b. / plant : water in 12°C out 7°C / Recovery : water in 40°C out 45°C

## CONTROL SYSTEM

The units are equipped with a controller designed to ensure energy saving and unit efficiency. Available functions :

- ATC outdoor high temperature protection function
- Demand limit
- Dynamic defrost
- Integrative heating
- Sound management
- Remote stand by
- Climatic control in heating and in cooling mode
- Remote cooling-heating
- Double set point function



## DIMENSIONS - MINIMUM OPERATING AREA - WEIGHT

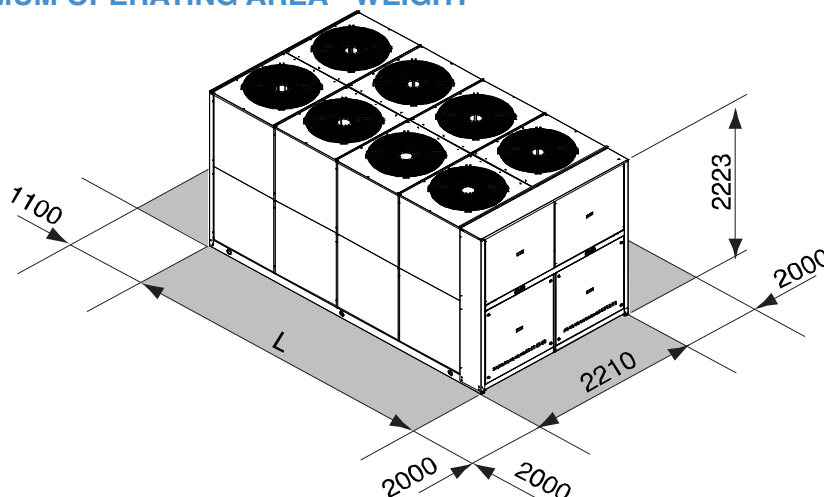

	350.5	390.6	440.6	490.6	
L	5030	5030	5030	5030	mm
Operating maximum weight*	4900	5110	5220	5300	kg

\* Weight refers to the unit IP with tank and pumping module 2 pumps.



# > RHV

## AIR COOLED WATER CHILLERS



### Units Series

#### Type

- IR chiller
- BR chiller brine

#### Available version

- VB Basic
- VD and VR on request

#### Available configuration

- AB Basic
- AS Low noise

### VB unit specifications

The RHV units are air-cooled water chillers using R407C ecological gas.

When developing the unit, special attention was paid to the issue of noise, in order to comply with increasingly strict laws on noise pollution. In fact, two noise attenuation levels are available (Basic, Low noise).

The range is completed with numerous accessories and options, including the possibility of having units equipped with pumping modules with 2 pumps 2 poles (for Basic Version) and 4 poles (for low noise Version).

The units are carefully built and tested, therefore installation only requires the electrical and hydraulic

### USER INTERFACING

The controller on the unit is designed to ensure energy-saving and efficiency. It enables the setting of:

- Double Set Point
- Demand Limit
- Noise control
- Heating in integration
- ATC function to protect in high ambient air conditions
- Function climate control evolved (temperature scrolling)

### Basic Version (VB) and Basic Configuration (AB)

- COMPRESSOR: 2 TWIN-SCREW semihermetic compressors able to modulate the COOLING capacity from 12,5 to 100%, mounted on rubber vibration dampers.
- REFRIGERANT CIRCUIT: 2 independent refrigerant circuits, complete with maximum and minimum pressure switches, PED safety valves, dehydrator filter, liquid/humidity indicator, compressor delivery and liquid shut-off valves, high and low pressure transducers electronic expansion valve which optimises the unit efficiency.
- PLANT SIDE HEAT EXCHANGER: shell and tube evaporator, fitted inside a shell of thermal insulation material to prevent condensation and heat exchange with the outside, protected to a minimum air temperature of  $-10^{\circ}\text{C}$  by means of a water differential pressure switch and an antifreeze heater.
- SOURCE SIDE HEAT EXCHANGER: finned coils with large heat exchange surface, made with copper pipes and notched aluminium fins,
- FANS: helical fans with crescent-shaped blades to limit noise
- ELECTRICAL PANEL: control electrical panel with a main door lock disconnecting switch, sequence meter, microprocessor controller with display (4 lines of 20 characters) containing the electrical equipment and all the components with minimum protection rating IP54.

### Basic Version (VB) and Low noise Configuration (AS)

In addition to the specification in Basic version (AB), the Low Noise version (AS) provides for the following configurations:

- FANS: reduced speed
- COMPRESSORS: positioned inside a soundproofed cabin, made with profiles and panels insulated with optimum sound-absorbing material.

### Main accessories/Options

**Integrated Pumping Modules** with 2 pumps, supplied in 4 different configurations:

- Pumps 2 poles standard head
- Pumps 2 poles high head
- Pumps 2 poles extra high head
- Pumps 4 poles standard head

**Condensation Control Device** (standard for AS), enables unit operation to outside air temperatures  $\geq -10^{\circ}\text{C}$

**Unit external Storage and Pumping Module** complete with insulated tank, single or twin pump and all hydronic components.

**Remote Control, Compressor Soft-starter, Compressor retiming condensers, Compressor and fan thermal magnet switches**



Common Data	360.2	410.2	460.2	520.2	580.2	630.2	680.2	780.2	900.2	1000.2	1150.2	1300.2	1450.2		
Supply	400 V – 3 ph – 50Hz													V-ph-Hz	
Quantity-type compressor.	2 - TWIN SCREW - 2 - 13/100%													-	
N° circ-Part load														-	
Quantity type evaporator	1 - SHELL & TUBE													-	
Water content evaporator	106	103	153	148	262	262	262	248	241	413	398	405	543	l	
Water connection IN/OUT	4" DN100			5" DN125			6" DN150			8" DN200				DN	
Quantity fan	AB - AS	8	8	8	8	10	10	10	12	14	14	16	20	24	n°
Fan speed	AB - AS	900	900	900	900	900	900	900	900	900	900	900	900	900	rpm
Operation weight	AB	3570	3580	3992	4328	4894	5089	5284	5826	6823	7928	8260	9216	9922	kg
	AS	3769	3779	4206	4557	5123	5318	5513	6055	7087	8192	8524	9480	10186	kg
F.L.A. Full load ampere		298	336	371	406	458	492	526	534	702	792	878	978	994	A

**Basic Configuration (AB)**

	360.2	410.2	460.2	520.2	580.2	630.2	680.2	780.2	900.2	1000.2	1150.2	1300.2	1450.2	
Cooling capacity	364	410	452	511	576	621	672	771	882	995	1149	1308	1430	kW
Total power input	145	168	186	205	228	247	261	293	340	391	446	509	494	kW
<b>EER</b>	<b>2,51</b>	<b>2,44</b>	<b>2,43</b>	<b>2,49</b>	<b>2,53</b>	<b>2,51</b>	<b>2,57</b>	<b>2,63</b>	<b>2,60</b>	<b>2,55</b>	<b>2,57</b>	<b>2,57</b>	<b>2,90</b>	-
<b>ESEER</b>	<b>3,28</b>	<b>3,21</b>	<b>3,20</b>	<b>3,30</b>	<b>3,35</b>	<b>3,33</b>	<b>3,41</b>	<b>3,53</b>	<b>3,46</b>	<b>3,40</b>	<b>3,46</b>	<b>3,47</b>	<b>3,95</b>	-
Water flow rate	17,4	19,6	21,6	24,4	27,5	29,7	32,1	36,8	42,1	47,5	54,9	62,5	68,3	l/s
Water pressure drop	54	50	44	50	39	45	53	43	55	57	46	56	46	kPa
Available static head	-	-	-	-	-	-	-	-	-	-	-	-	-	-
<b>Sound level</b>	<b>360.2</b>	<b>410.2</b>	<b>460.2</b>	<b>520.2</b>	<b>580.2</b>	<b>630.2</b>	<b>680.2</b>	<b>780.2</b>	<b>900.2</b>	<b>1000.2</b>	<b>1150.2</b>	<b>1300.2</b>	<b>1450.2</b>	
Totale - SWL	99	99	99	100	100	100	100	101	102	102	103	104	105	dB(A)
SPL 1 m	79	79	79	80	80	80	80	80	81	81	82	82	82	dB(A)
SPL 5 m	71	71	71	72	72	72	72	73	74	74	75	75	76	dB(A)
SPL 10 m	67	67	67	68	68	68	68	69	70	69	70	71	72	dB(A)

**Low noise Configuration (AS)**

	360.2	410.2	460.2	520.2	580.2	630.2	680.2	780.2	900.2	1000.2	1150.2	1300.2	1450.2	
Cooling capacity	350	396	435	494	555	601	650	743	853	963	1104	1260	1384	kW
Total power input	146	169	188	207	230	249	263	295	342	394	453	515	494	kW
<b>EER</b>	<b>2,41</b>	<b>2,34</b>	<b>2,32</b>	<b>2,38</b>	<b>2,41</b>	<b>2,42</b>	<b>2,47</b>	<b>2,52</b>	<b>2,50</b>	<b>2,45</b>	<b>2,44</b>	<b>2,45</b>	<b>2,80</b>	-
<b>ESEER</b>	<b>3,15</b>	<b>3,08</b>	<b>3,06</b>	<b>3,16</b>	<b>3,20</b>	<b>3,20</b>	<b>3,27</b>	<b>3,37</b>	<b>3,33</b>	<b>3,26</b>	<b>3,28</b>	<b>3,30</b>	<b>3,82</b>	-
Water flow rate	16,7	18,9	20,8	23,6	26,5	28,7	31,0	35,5	40,7	46,0	52,8	60,2	66,1	l/s
Water pressure drop	50	47	41	47	36	42	50	40	51	53	42	52	43	kPa
Available static head	-	-	-	-	-	-	-	-	-	-	-	-	-	-
<b>Sound level</b>	<b>360.2</b>	<b>410.2</b>	<b>460.2</b>	<b>520.2</b>	<b>580.2</b>	<b>630.2</b>	<b>680.2</b>	<b>780.2</b>	<b>900.2</b>	<b>1000.2</b>	<b>1150.2</b>	<b>1300.2</b>	<b>1450.2</b>	
Totale - SWL	94	94	94	95	95	95	95	96	97	97	98	99	100	dB(A)
SPL 1 m	74	74	74	75	75	75	75	75	76	76	77	77	77	dB(A)
SPL 5 m	66	66	66	67	67	67	67	68	69	69	70	70	71	dB(A)
SPL 10 m	62	62	62	63	63	63	63	64	64	64	65	66	67	dB(A)

**NOTES:**

Cooling performance values measured with EWT/LWT 12/7°C - AT 35°C D.B.

ESEER : European seasonal efficiency rating in cooling.

SWL Sound power levels, with reference to 1x10<sup>-12</sup> W in dB(A) measured in compliance with ISO 9614 standards, is certified according to the Eurovent certification program. Eurovent certification (E) exclusively refers to the Total Sound Power in dB(A), which is therefore the only binding acoustic specification.

SPL Sound pressure levels, with reference to 2x10<sup>-5</sup> Pa calculated by applying the ISO-3744 relation (Eurovent 8/1) and refer to a distance of 1/5/10 meter away from the external surface of units operating in standard condition (ambient air T=35°C, water 12/7°C) in cooling mode, in open field with directivity factor 2.

**Dimensions and minimum operating space**

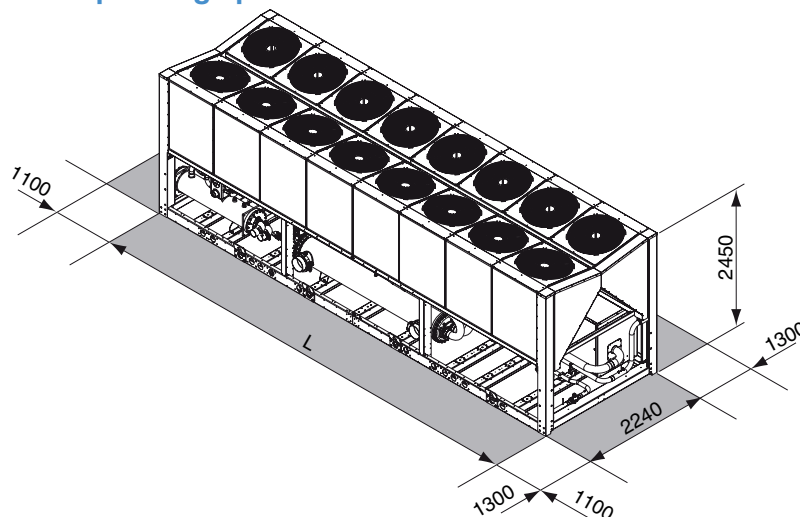

	360.2	410.2	460.2	520.2	580.2	630.2	680.2	780.2	900.2	1000.2	1150.2	1300.2	1450.2	
L	4070	4070	4070	4070	5000	5000	5000	5950	6900	6900	7850	10000	11900	mm

# > RHV

## AIR WATER CHILLER FOR OUTDOOR INSTALLATION



### Available range

#### Unit type

IR	Chiller
BR	Chiller Brine

#### Version

VB	Base version
VD	Desuperheater version
VR	Total recovery version

#### Acoustic setting up

AB	Base setting up
AS	Low noise setting up
AX	eXtra low noise setting up

#### Source temperature level

M	Medium temperature level
A	High temperature level

### Unit description

This range of air-water chillers are designed to meet the climate control and air conditioning needs of large capacity systems in the industrial and commercial sectors. Suitable for outdoor installation, as standard the units are equipped with 2 TWIN-SCREW semihermetic compressors mounted on rubber vibration dampers, able to modulate the capacity of the unit from minimum 12.5 (not for all configurations) to 100%, plant side exchanger shell and tube type complete with Victaulic water connections, fitted inside a shell of thermal insulation material to prevent condensation and heat exchange with the outside, optimised for R134a with high efficiency grooved tubes, protected by means of a water differential pressure switch and from the winter

freeze to a minimum air temperature of -10°C by means of an antifreeze heater, source side exchanger finned coils with large heat exchange surface, made with copper pipes and louvered aluminium fins, 2 independent refrigerant circuits, complete with electronic expansion valve which optimises unit efficiency at full and partial loads and enables maximum seasonal efficiency, maximum and minimum pressure switch, PED safety valves, dehydrator filter, liquid/moisture indicator, compressor discharge and liquid shut-off valves, high and low pressure transducers, electrical panel with minimum protection IP54 containing the electrical equipment and all the components to control and command the unit complete with main supply breaker with door lock function, phase sequence control device, microprocessor controller with display (4 lines of 20 characters). In addition to the standard features the Low noise setting up (AS) is equipped with fans reduced speed and compressors positioned inside a soundproofed cabin, made with profiles and panels insulated with acoustic material. In addition to the standard features the eXtra low noise setting up (AX) is equipped with coils with larger surface in order to further reduce the fans speed and compressors positioned inside a soundproofed cabin, made with profiles and panels insulated with superior acoustic material. The range is completed with numerous accessories and options, including the possibility of having units equipped with pumping modules with 2 pumps, 2 poles for Basic Version and 4 poles for Low Noise and Extra Low Noise setting up. The units are carefully built and tested, therefore installation only requires the electrical and hydraulic connections.

### Options

- [Compressor starting](#)
  - standard (contactors)
  - soft starter
- [Compressors power factor correction](#)
- [Electrical load protection](#)
  - standard (fuses)
  - thermal magnetic circuit breakers

### Accessories

- [Integrated Pumping Modules](#) with 2 pumps, supplied in 4 different configurations:
  - Pumps 2 poles standard head
  - Pumps 2 poles high head
  - Pumps 2 poles extra high head
  - Pumps 4 poles standard head
- [Condensation Control Device](#) (standard for AS and AX), enables unit operation to outside air temperatures = -10°C)
- [Spring vibration dampers](#)
- [Coil protection grilles](#)
- [Antintrusion protection grilles](#)
- [External Water Storage Tank and Pumping Module](#) complete with insulated carbon steel tank, single or twin pump and all hydronic components.
- [Antifreeze electrical heaters for Storage tank](#)
- [Remote controller](#)
- [Serial Interface Modbus on RS 485](#)
- [Programmer clock](#)
- [Phase sequence and voltage controller](#)
- [High and low pressure gauges](#)
- [Compressor suction shut-off valve](#)
- [Water flow switch](#)



**NET NOMINAL performances - Standard plants - EUROVENT certified data**

IR	Base setting up (AB)	330.2	370.2	420.2	470.2	510.2	590.2	670.2	740.2	800.2	900.2	1000.2	1150.2	
A35W7	Cooling capacity	329	363	412	464	507	589	660	738	795	883	980	1104	kW
	Power input	122	139	154	169	192	215	230	265	288	332	359	389	kW
	EER	2,71	2,6	2,68	2,74	2,63	2,74	2,88	2,78	2,77	2,66	2,73	2,84	W/W
	ESEER	3,34	3,23	3,33	3,44	3,31	3,46	3,54	3,51	3,51	3,42	3,48	3,69	W/W
	Water flow rate	15,9	17,5	19,8	22,4	24,4	28,4	31,8	35,5	38,3	42,6	47,2	53,2	l/s
	Pressure drops	49	57	44	56	53	53	44	45	52	60	42	56	kPa
IR	Low noise setting up (AS)	330.2	370.2	420.2	470.2	510.2	590.2	670.2	740.2	800.2	900.2	1000.2	1150.2	
A35W7	Cooling capacity	319	351	396	443	490	563	638	710	763	849	937	1071	kW
	Power input	120	139	154	171	191	219	239	270	296	334	367	400	kW
	EER	2,65	2,52	2,58	2,6	2,57	2,57	2,67	2,63	2,58	2,54	2,55	2,68	W/W
	ESEER	3,45	3,29	3,32	3,38	3,32	3,31	3,44	3,39	3,35	3,32	3,31	3,55	W/W
	Water flow rate	15,3	16,9	19,1	21,4	23,6	27,1	30,7	34,2	36,7	40,9	45,1	51,6	l/s
	Pressure drops	46	54	40	51	50	48	41	41	47	55	39	53	kPa
IR	eXtra low noise setting up (AX)	330.2	370.2	420.2	470.2	510.2	590.2	670.2	740.2	800.2	900.2	1000.2	1150.2	
A35W7	Cooling capacity	305	348	389	432	486	547	632	695	748	857	937	1067	kW
	Power input	125	141	157	176	194	230	249	277	304	337	374	412	kW
	EER	2,44	2,47	2,47	2,45	2,51	2,38	2,54	2,5	2,47	2,55	2,51	2,59	W/W
	ESEER	3,22	3,29	3,22	3,2	3,28	3,1	3,32	3,28	3,24	3,39	3,3	3,48	W/W
	Water flow rate	14,7	16,8	18,7	20,8	23,4	26,3	30,4	33,4	36	41,3	45,1	51,4	l/s
	Pressure drops	42	53	39	48	49	46	40	40	46	56	39	52	kPa

Data declared according to EN 14511. The values are referred to units without options and accessories.

EER (Energy Efficiency Ratio) = ratio of the total cooling capacity to the effective power input of the unit

ESEER (European Seasonal Energy Efficiency Ratio)

\_\_\_\_\_ = Unit in A CLASS.

A35W7 = source : air in 35°C d.b. / plant : water in 12°C out 7°C

**Acoustic performances**

Base setting up (AB)	330.2	370.2	420.2	470.2	510.2	590.2	670.2	740.2	800.2	900.2	1000.2	1150.2	
Sound power level <sup>(E)</sup>	98	98	98	98	100	100	100	101	101	102	102	103	dB(A)
Sound pressure level at 1 meter	79	79	79	79	80	80	80	80	80	81	81	82	dB(A)
Sound pressure level at 5 meters	71	71	71	71	72	72	72	73	73	74	73	74	dB(A)
Sound pressure level at 10 meters	66	66	66	66	67	67	67	69	69	69	69	70	dB(A)
Low noise setting up (AS)	330.2	370.2	420.2	470.2	510.2	590.2	670.2	740.2	800.2	900.2	1000.2	1150.2	
Sound power level <sup>(E)</sup>	93	93	93	93	94	94	94	96	96	97	97	98	dB(A)
Sound pressure level at 1 meter	73	73	73	73	74	74	74	75	75	75	75	76	dB(A)
Sound pressure level at 5 meters	65	65	65	65	67	66	66	67	67	68	68	69	dB(A)
Sound pressure level at 10 meters	61	61	61	61	62	62	62	63	63	64	64	65	dB(A)
eXtra low noise setting up (AX)	330.2	370.2	420.2	470.2	510.2	590.2	670.2	740.2	800.2	900.2	1000.2	1150.2	
Sound power level <sup>(E)</sup>	87	87	87	87	88	88	90	91	91	92	92	93	dB(A)
Sound pressure level at 1 meter	67	67	67	67	68	68	69	69	69	70	70	71	dB(A)
Sound pressure level at 5 meters	59	59	59	59	61	60	62	63	63	63	63	65	dB(A)
Sound pressure level at 10 meters	55	55	55	55	56	56	57	58	58	59	59	60	dB(A)

(E): EUROVENT certified data

The acoustic performances are referred to units operating in cooling mode at nominal conditions A35W7.

Unit placed in free field on reflecting surface (directional factor equal to 2).

The sound power level is measured according to ISO 9614 standard.

The sound pressure level is calculated according to ISO 3744 and is referred to a distance of 1/5/10 metres from the external surface of the unit.

**Technical data**

Unit	330.2	370.2	420.2	470.2	510.2	590.2	670.2	740.2	800.2	900.2	1000.2	1150.2	
Power supply	400 - 3 - 50												V-ph-Hz
Compressor type	twin-screw												-
N° compressors / N° refrigerant circuits	2 / 2												n°
Part load	12.5 / 100% stepless												-
Plant side heat exchanger type	shell & tube												-
Source side heat exchanger type	finned coil												-
Fans type	axial												n°
N° fans (AB / AS)	8	8	8	8	10	10	10	12	12	14	14	16	l
N° fans (AX)	8	8	8	8	10	10	12	14	14	16	16	20	
Hydraulic fittings (victaulic)	DN100	DN100	DN125	DN125	DN125	DN150	DN150	DN150	DN150	DN200	DN200	DN200	-

**Electrical data**

Standard unit		330.2	370.2	420.2	470.2	510.2	590.2	670.2	740.2	800.2	900.2	1000.2	1150.2	
<b>FLA</b> - Full load current at maximum tolerated conditions	AB	274	304	332	360	409	469	469	557	594	684	746	755	A
	AS	274	304	332	360	409	469	469	557	594	684	746	755	
	AX	258	288	316	344	389	449	454	537	574	661	723	732	
<b>FLI</b> - Full load power input at maximum tolerated conditions	AB	164	184	200	216	242	282	282	339	364	412	452	456	kW
	AS	164	184	200	216	242	282	282	339	364	412	452	456	
	AX	157	177	193	209	233	273	275	330	355	402	442	446	
<b>MIC</b> - Maximum instantaneous current of the unit	AB	504	592	689	717	838	921	921	751	788	958	1053	1062	A
	AS	504	592	689	717	838	921	921	751	788	958	1053	1062	
	AX	488	576	673	701	818	901	906	731	768	935	1030	1039	

**Operative range**

Temperature	Unit type	Cooling		
		min	max	
Outdoor air inlet temperature	IR, BR	15 (-10*)	46 (50**)	(°C)
Water outlet temperature	IR	5	15	(°C)
Water outlet temperature	BR	-8	5	(°C)
Water outlet temperature (VD)	IR, BR	35	55	(°C)
Water outlet temperature (VR)	IR, BR	35	55	(°C)

\* with fans modulating control option (condensation / evaporation control)

\*\* with ATC outdoor high temperature protection function

**USER INTERFACING**

The controller on the unit is designed to ensure energy-saving and efficiency. It enables the setting of:

- Double Set Point
- Demand Limit
- ATC function to avoid the block of the unit with high outdoor air temperature
- Dinamic set point
- Noise emission control
- Remote stand by



### VD and VR versions

These units allow to recover the heating power, otherwise wasted on air, through an additional heat exchanger.

#### DESUPERHEATERS VERSION VD

Allows the production of cold water as in the standard version and, simultaneously, of hot water at temperatures from 35 to 50 °C. This is achieved by inserting, between the compressor and finned coil, a heat exchanger water-gas cooler which allows for heat recovery from 15 to 20% of thermal power.

#### TOTAL RECOVERY VERSION VR

Allows the production of cold water and simultaneously of hot water at temperatures from 35 to 50 °C by using a heat exchanger, water-gas cooler which allows the total recovery of thermal power. The inclusion and exclusion of the total heat recovery, is done by a valve placed on the discharge of the compressors on each circuit.

#### Desupeheater Version (VD) - NET NOMINAL performances

IR	Base setting up (AB)	330.2	370.2	420.2	470.2	510.2	590.2	670.2	740.2	800.2	900.2	1000.2	1150.2	
A35W7 - W45	Cooling capacity	342	377	429	482	526	612	687	767	827	918	1018	1148	kW
	Total power input	118	136	149	165	187	209	223	257	279	323	349	378	kW
	EER	2,9	2,78	2,87	2,93	2,81	2,94	3,08	2,99	2,96	2,85	2,92	3,03	W/W
	HRE	3,69	3,58	3,69	3,75	3,63	3,76	3,91	3,81	3,78	3,67	3,76	3,86	W/W
	Water flow rate	16,5	18,2	20,6	23,3	25,4	29,5	33	36,9	39,9	44,3	49	55,4	l/s
	Water pressure drop	53	62	47	60	58	57	47	48	56	65	46	61	kPa
	Heating recovery capacity	93	109	122	135	152	171	185	212	231	266	292	313	kW
	Water flow rate recovery	4,5	5,2	5,8	6,4	7,2	8,2	8,8	10,1	11,1	12,7	14	15	l/s
	Water pressure drop recovery	10	13	17	10	13	12	14	18	15	12	15	17	kPa

#### Total Recovery Version (VR) - NET NOMINAL performances

IR	Base setting up (AB)	330.2	370.2	420.2	470.2	510.2	590.2	670.2	740.2	800.2	900.2	1000.2	1150.2	
A35W7 - W45	Cooling capacity	325	359	413	468	519	593	653	742	799	897	989	1122	kW
	Total power input	109	126	139	153	169	193	212	238	263	297	330	352	kW
	EER	3	2,84	2,97	3,05	3,08	3,07	3,09	3,11	3,04	3,02	3	3,18	W/W
	HRE	6,95	6,64	6,9	7,06	7,11	7,09	7,13	7,17	7,04	6,99	6,95	7,32	W/W
	Water flow rate	15,7	17,3	19,9	22,6	25	28,6	31,4	35,7	38,5	43,3	47,6	54,1	l/s
	Water pressure drop	48	56	44	56	56	54	43	45	52	62	43	58	kPa
	Heating recovery capacity	429	479	545	614	680	777	855	968	1049	1180	1303	1457	kW
	Water flow rate recovery	20,5	22,9	26	29,3	32,5	37,1	40,8	46,3	50,1	56,4	62,2	69,6	l/s
	Water pressure drop recovery	27	33	43	45	47	43	47	44	52	47	48	50	kPa

Data declared according to EN 14511. The values are referred to units without options and accessories.

EER (Energy Efficiency Ratio) = ratio of the total cooling capacity to the effective power input of the unit

HRE (Heat Recovery Efficiency) = ratio of the total capacity of the system (heating plus cooling capacity) to the effective power input

A35W7 - W45 = source : air in 35°C d.b. / plant : water in 12°C out 7°C / Recovery : water in 40°C out 45°C

### DIMENSIONS - MINIMUM OPERATING AREA - WEIGHT

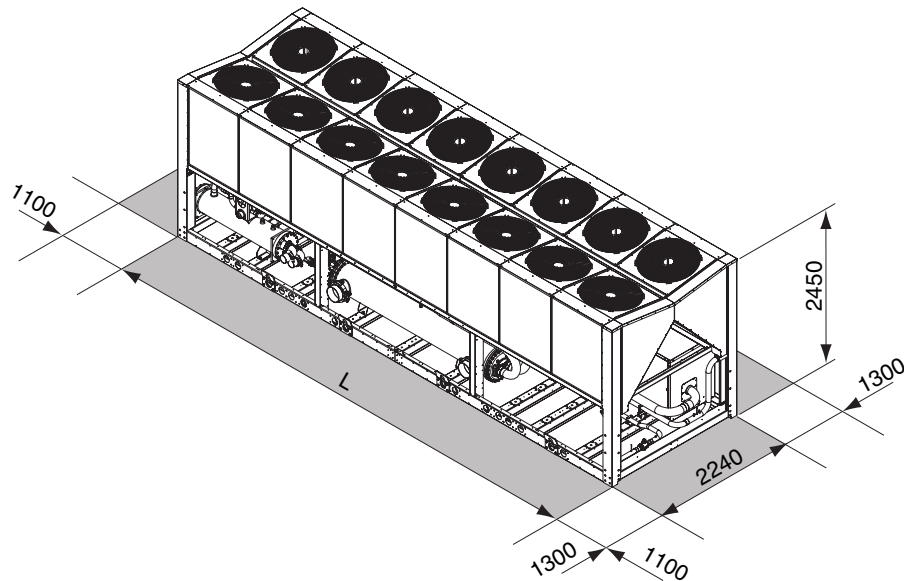

		330.2	370.2	420.2	470.2	510.2	590.2	670.2	740.2	800.2	900.2	1000.2	1150.2	
L	AB	4070	4070	4070	4070	5005	5005	5005	5950	5950	6900	6900	7810	mm
	AS	4070	4070	4070	4070	5005	5005	5005	5950	5950	6900	6900	7810	mm
	AX	4070	4070	4070	4070	5005	5005	5950	6900	6900	7810	7810	10000	mm
Operating maximum weight*		3734	3800	4192	4534	4731	5059	5318	6567	6715	7377	8032	9091	kg

\* Weight refers to the unit IR with tank and pumping module 2 pumps.



# > RHV HE

AIR WATER CHILLER  
FOR OUTDOOR INSTALLATION



## Available range

### Unit type

IR	Chiller
BR	Chiller Brine

### Version

VB	Base version
VD	Desuperheater version
VR	Total recovery version

### Acoustic setting up

AB	Base setting up
AS	Low noise setting up
AX	eXtra low noise setting up

### Source temperature level

M	Medium temperature level
A	High temperature level

## Unit description

This range of air-water chillers are designed to meet the climate control and air conditioning needs of large capacity systems in the industrial and commercial sectors. Suitable for outdoor installation, as standard the units are equipped with 2 TWIN-SCREW semihermetic compressors mounted on rubber vibration dampers, able to modulate the capacity of the unit from minimum 12.5 (not for all configurations) to 100%, plant side exchanger shell and tube type complete with Victaulic water connections, fitted inside a shell of thermal insulation material to prevent condensation and heat exchange with the outside, optimised for R134a with high efficiency grooved tubes, protected by means of a water differential pressure switch and from the winter

freeze to a minimum air temperature of -10°C by means of an antifreeze heater, source side exchanger finned coils with large heat exchange surface, made with copper pipes and louvered aluminium fins, 2 independent refrigerant circuits, complete with electronic expansion valve which optimises unit efficiency at full and partial loads and enables maximum seasonal efficiency, maximum and minimum pressure switch, PED safety valves, dehydrator filter, liquid/moisture indicator, compressor discharge and liquid shut-off valves, high and low pressure transducers, electrical panel with minimum protection IP54 containing the electrical equipment and all the components to control and command the unit complete with main supply breaker with door lock function, phase sequence control device, microprocessor controller with display (4 lines of 20 characters). In addition to the standard features the Low noise setting up (AS) is equipped with fans reduced speed and compressors positioned inside a soundproofed cabin, made with profiles and panels insulated with acoustic material. In addition to the standard features the eXtra low noise setting up (AX) is equipped with coils with larger surface in order to further reduce the fans speed and compressors positioned inside a soundproofed cabin, made with profiles and panels insulated with superior acoustic material. The range is completed with numerous accessories and options, including the possibility of having units equipped with pumping modules with 2 pumps, 2 poles for Basic Version and 4 poles for Low Noise and Extra Low Noise setting up. The units are carefully built and tested, therefore installation only requires the electrical and hydraulic connections.

## Options

### Compressor starting

- standard (contactors)
- soft starter

### Compressors power factor correction

### Electrical load protection

- standard (fuses)
- thermal magnetic circuit breakers

## Accessories

**Integrated Pumping Modules** with 2 pumps, supplied in 4 different configurations:

- Pumps 2 poles standard head
- Pumps 2 poles high head
- Pumps 2 poles extra high head
- Pumps 4 poles standard head

**Condensation Control Device** (standard for AS and AX), enables unit operation to outside air temperatures  $\geq -10^{\circ}\text{C}$

### Spring vibration dampers

### Coil protection grilles

### Antintrusion protection grilles

**External Water Storage Tank and Pumping Module** complete with insulated carbon steel tank, single or twin pump and all hydronic components.

### Antifreeze electrical heaters for Storage tank

### Remote controller

### Serial Interface Modbus on RS 485

### Programmer clock

### Phase sequence and voltage controller

### High and low pressure gauges

### Compressor suction shut-off valve

### Water flow switch

**NET NOMINAL performances - Standard plants - EUROVENT certified data**

IR	Base setting up (AB)	330.2	370.2	420.2	470.2	510.2	590.2	670.2	740.2	800.2	900.2	1000.2	1150.2	
A35W7	Cooling capacity	356	395	451	502	557	638	686	796	858	970	1079	1172	kW
	Power input	118	130	147	163	177	206	220	257	278	318	349	368	kW
	<b>EER</b>	<b>3,02</b>	<b>3,04</b>	<b>3,07</b>	<b>3,08</b>	<b>3,14</b>	<b>3,1</b>	<b>3,12</b>	<b>3,09</b>	<b>3,09</b>	<b>3,05</b>	<b>3,09</b>	<b>3,19</b>	<b>W/W</b>
	<b>ESEER</b>	<b>3,61</b>	<b>3,63</b>	<b>3,65</b>	<b>3,69</b>	<b>3,72</b>	<b>3,74</b>	<b>3,77</b>	<b>3,74</b>	<b>3,74</b>	<b>3,7</b>	<b>3,76</b>	<b>3,87</b>	<b>W/W</b>
	Water flow rate	17,2	19	21,7	24,2	26,8	30,7	33,1	38,4	41,3	46,7	52,1	56,5	l/s
	Pressure drops	51	45	40	48	39	49	52	57	50	51	64	53	kPa
IR	Low noise setting up (AS)	330.2	370.2	420.2	470.2	510.2	590.2	670.2	740.2	800.2	900.2	1000.2	1150.2	
A35W7	Cooling capacity	347	386	438	485	544	618	675	774	832	941	1044	1152	kW
	Power input	115	128	145	163	175	208	227	259	283	318	350	374	kW
	<b>EER</b>	<b>3,03</b>	<b>3,03</b>	<b>3,03</b>	<b>2,99</b>	<b>3,1</b>	<b>2,98</b>	<b>2,98</b>	<b>2,99</b>	<b>2,94</b>	<b>2,96</b>	<b>2,98</b>	<b>3,08</b>	<b>W/W</b>
	<b>ESEER</b>	<b>3,81</b>	<b>3,8</b>	<b>3,79</b>	<b>3,68</b>	<b>3,86</b>	<b>3,84</b>	<b>3,85</b>	<b>3,86</b>	<b>3,76</b>	<b>3,82</b>	<b>3,87</b>	<b>3,98</b>	<b>W/W</b>
	Water flow rate	16,7	18,6	21,1	23,4	26,1	29,8	32,5	37,3	40	45,3	50,4	55,5	l/s
	Pressure drops	49	43	38	45	37	46	51	54	47	48	60	51	kPa
IR	eXtra low noise setting up (AX)	330.2	370.2	420.2	470.2	510.2	590.2	670.2	740.2	800.2	900.2	1000.2	1150.2	
A35W7	Cooling capacity	335	376	422	463	529	590	650	741	799	913	1022	1121	kW
	Power input	117	130	149	169	182	218	238	269	294	323	362	394	kW
	<b>EER</b>	<b>2,85</b>	<b>2,88</b>	<b>2,82</b>	<b>2,74</b>	<b>2,91</b>	<b>2,71</b>	<b>2,73</b>	<b>2,76</b>	<b>2,72</b>	<b>2,83</b>	<b>2,82</b>	<b>2,85</b>	<b>W/W</b>
	<b>ESEER</b>	<b>3,69</b>	<b>3,71</b>	<b>3,66</b>	<b>3,64</b>	<b>3,76</b>	<b>3,62</b>	<b>3,64</b>	<b>3,69</b>	<b>3,66</b>	<b>3,76</b>	<b>3,74</b>	<b>3,78</b>	<b>W/W</b>
	Water flow rate	16,1	18,1	20,3	22,3	25,4	28,4	31,3	35,7	38,5	44	49,3	54	l/s
	Pressure drops	45	41	35	41	35	42	47	49	43	45	57	48	kPa

Data declared according to **EN 14511**. The values are referred to units without options and accessories.

**EER** (Energy Efficiency Ratio) = ratio of the total cooling capacity to the effective power input of the unit

**ESEER** (European Seasonal Energy Efficiency Ratio)

\_\_\_\_\_ = Unit in **A CLASS**.

**A35W7** = source : air in 35°C d.b. / plant : water in 12°C out 7°C

**Acoustic performances**

Base setting up (AB)	330.2	370.2	420.2	470.2	510.2	590.2	670.2	740.2	800.2	900.2	1000.2	1150.2	
Sound power level <sup>(E)</sup>	97	97	97	97	99	99	99	100	100	101	101	102	dB(A)
Sound pressure level at 1 meter	77	77	77	77	79	78	78	79	79	80	79	80	dB(A)
Sound pressure level at 5 meters	69	69	69	69	71	71	71	72	72	73	72	73	dB(A)
Sound pressure level at 10 meters	65	65	65	65	67	67	67	67	67	68	68	69	dB(A)
Low noise setting up (AS)	330.2	370.2	420.2	470.2	510.2	590.2	670.2	740.2	800.2	900.2	1000.2	1150.2	
Sound power level <sup>(E)</sup>	92	92	92	92	93	93	93	95	95	96	96	97	dB(A)
Sound pressure level at 1 meter	72	72	72	72	73	72	72	74	74	75	74	75	dB(A)
Sound pressure level at 5 meters	64	64	64	64	65	65	65	67	67	68	67	68	dB(A)
Sound pressure level at 10 meters	60	60	60	60	61	61	61	62	62	63	63	64	dB(A)
eXtra low noise setting up (AX)	330.2	370.2	420.2	470.2	510.2	590.2	670.2	740.2	800.2	900.2	1000.2	1150.2	
Sound power level <sup>(E)</sup>	87	87	88	88	90	90	90	91	91	92	92	93	dB(A)
Sound pressure level at 1 meter	67	67	68	68	70	69	69	70	70	71	70	71	dB(A)
Sound pressure level at 5 meters	59	59	60	60	62	62	62	63	63	64	63	64	dB(A)
Sound pressure level at 10 meters	55	55	56	56	58	58	58	58	58	59	59	60	dB(A)

**(E): EUROVENT** certified data

The acoustic performances are referred to units operating in cooling mode at nominal conditions A35W7.

Unit placed in free field on reflecting surface (directional factor equal to 2).

The sound power level is measured according to ISO 9614 standard.

The sound pressure level is calculated according to ISO 3744 and is referred to a distance of 1/5/10 metres from the external surface of the unit.

**Technical data**

Unit	330.2	370.2	420.2	470.2	510.2	590.2	670.2	740.2	800.2	900.2	1000.2	1150.2	
Power supply	400 - 3 - 50												V-ph-Hz
Compressor type	twin-screw												-
N° compressors / N° refrigerant circuits	2 / 2												n°
Part load	12.5 / 100% stepless												-
Plant side heat exchanger type	shell & tube												-
Source side heat exchanger type	finned coil												-
Fans type	axial												n°
N° fans	8			10			12		14	16		20	l
Hydraulic fittings (victaulic)	DN150			DN200									-

**Electrical data**

Standard unit	330.2	370.2	420.2	470.2	510.2	590.2	670.2	740.2	800.2	900.2	1000.2	1150.2	
<b>FLA</b> - Full load current at maximum tolerated conditions	274	304	341	369	409	478	478	565	602	693	772	772	A
<b>FLI</b> - Full load power input at maximum tolerated conditions	164	184	204	220	242	286	286	343	368	416	464	464	kW
<b>MIC</b> - Maximum instantaneous current of the unit	504	592	698	726	838	930	930	759	796	967	1079	1079	A

**Operative range**

**Cooling**

Temperature	Unit type	min	max	
Outdoor air inlet temperature	IR, BR	15 (-10*)	50 (55**)	(°C)
Water outlet temperature	IR	5	15	(°C)
Water outlet temperature	BR	-8	5	(°C)
Water outlet temperature (VD)	IR, BR	35	50	(°C)
Water outlet temperature (VR)	IR, BR	35	50	(°C)

\* with fans modulating control option (condensation / evaporation control)

\*\* with ATC outdoor high temperature protection function

**USER INTERFACING**

The controller on the unit is designed to ensure energy-saving and efficiency. It enables the setting of:

- Double Set Point
- Demand Limit
- ATC function to avoid the block of the unit with high outdoor air temperature
- Dinamic set point
- Noise emission control
- Remote stand by





### VD and VR versions

These units allow to recover the heating power, otherwise wasted on air, through an additional heat exchanger.

#### DESUPERHEATERS VERSION VD

Allows the production of cold water as in the standard version and, simultaneously, of hot water at temperatures from 35 to 50 ° C. This is achieved by inserting, between the compressor and finned coil, a heat exchanger water-gas cooler which allows for heat recovery from 15 to 20% of thermal power.

#### TOTAL RECOVERY VERSION VR

Allows the production of cold water and simultaneously of hot water at temperatures from 35 to 50 °C by using a heat exchanger, water-gas cooler which allows the total recovery of thermal power. The inclusion and exclusion of the total heat recovery, is done by a valve placed on the discharge of the compressors on each circuit.

#### Desupeheater Version (VD) - NET NOMINAL performances

IR	Base setting up (AB)	330.2	370.2	420.2	470.2	510.2	590.2	670.2	740.2	800.2	900.2	1000.2	1150.2	
A35W7 - W45	Cooling capacity	370	411	469	522	578	663	714	827	892	1008	1122	1218	kW
	Total power input	115	127	143	159	173	202	214	251	272	311	341	359	kW
	<b>EER</b>	<b>3,21</b>	<b>3,23</b>	<b>3,27</b>	<b>3,27</b>	<b>3,34</b>	<b>3,29</b>	<b>3,33</b>	<b>3,29</b>	<b>3,28</b>	<b>3,24</b>	<b>3,28</b>	<b>3,39</b>	<b>W/W</b>
	<b>HRE</b>	<b>4,01</b>	<b>4,05</b>	<b>4,08</b>	<b>4,09</b>	<b>4,18</b>	<b>4,11</b>	<b>4,15</b>	<b>4,11</b>	<b>4,12</b>	<b>4,08</b>	<b>4,1</b>	<b>4,22</b>	<b>W/W</b>
	Water flow rate	17,8	19,8	22,6	25,1	27,8	31,9	34,4	39,9	43	48,6	54,2	58,7	l/s
	Water pressure drop	55	49	43	52	42	53	56	62	54	55	69	57	kPa
	Heating recovery capacity	93	104	116	130	144	165	177	207	227	259	278	297	kW
	Water flow rate recovery	4,4	5	5,5	6,2	6,9	7,9	8,5	9,9	10,8	12,4	13,3	14,2	l/s
	Water pressure drop recovery	10	12	15	9	11	11	13	18	15	11	14	15	kPa

#### Total Recovery Version (VR) - NET NOMINAL performances

IR	Base setting up (AB)	330.2	370.2	420.2	470.2	510.2	590.2	670.2	740.2	800.2	900.2	1000.2	1150.2	
A35W7 - W45	Cooling capacity	354	390	447	499	552	635	684	794	865	992	1082	1169	kW
	Total power input	107	121	133	147	161	187	200	233	251	283	313	333	kW
	<b>EER</b>	<b>3,31</b>	<b>3,23</b>	<b>3,37</b>	<b>3,4</b>	<b>3,42</b>	<b>3,4</b>	<b>3,43</b>	<b>3,4</b>	<b>3,44</b>	<b>3,5</b>	<b>3,45</b>	<b>3,51</b>	<b>W/W</b>
	<b>HRE</b>	<b>7,58</b>	<b>7,41</b>	<b>7,69</b>	<b>7,76</b>	<b>7,79</b>	<b>7,74</b>	<b>7,8</b>	<b>7,76</b>	<b>7,84</b>	<b>7,95</b>	<b>7,86</b>	<b>7,97</b>	<b>W/W</b>
	Water flow rate	17,1	18,8	21,5	24	26,5	30,6	33	38,3	41,7	47,8	52,2	56,3	l/s
	Water pressure drop	51	44	39	47	38	49	52	57	51	53	64	53	kPa
	Heating recovery capacity	456	505	574	639	705	813	874	1016	1104	1261	1380	1486	kW
	Water flow rate recovery	21,8	24,1	27,4	30,5	33,7	38,8	41,8	48,5	52,7	60,3	65,9	71	l/s
	Water pressure drop recovery	30	37	48	49	51	47	49	49	58	54	54	52	kPa

Data declared according to **EN 14511**. The values are referred to units without options and accessories.

**EER** (Energy Efficiency Ratio) = ratio of the total cooling capacity to the effective power input of the unit

**HRE** (Heat Recovery Efficiency) = ratio of the total capacity of the system (heating plus cooling capacity) to the effective power input

**A35W7 - W45** = source : air in 35°C d.b. / plant : water in 12°C out 7°C / Recovery : water in 40°C out 45°C

### DIMENSIONS - MINIMUM OPERATING AREA - WEIGHT

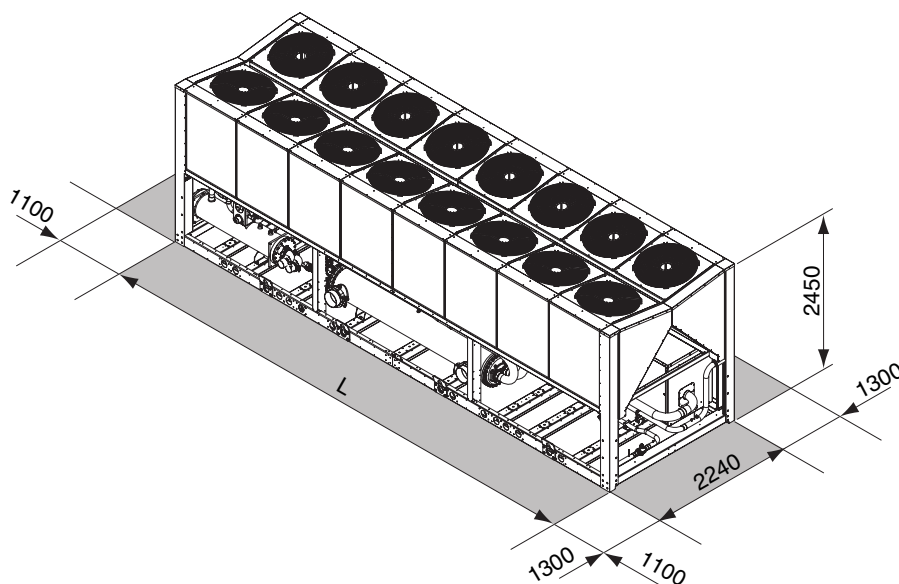

	330.2	370.2	420.2	470.2	510.2	590.2	670.2	740.2	800.2	900.2	1000.2	1150.2		
L (AB-AS-AX)	4070		5005			5950		6900		7810		10000		mm
Operating maximum weight*	3950	4116	4971	5303	5546	5687	6004	7345	7378	8589	9494	10220	kg	

\* Weight refers to the unit IR with tank and pumping module 2 pumps.

# > RMP

## AIR-WATER CHILLERS AND HEAT PUMPS FOR INDOOR INSTALLATION



### Available range

#### Unit type

IR	Chiller
IP	Heat pump (reversible on the refrigerant side)
BR	Chiller Brine
BP	Heat pump Brine (reversible on the refrigerant side)

#### Versions

VB	Base Version
VP	Pump version
VA	Tank version

#### Acoustic setting up

AB	Base setting up
AS	Low noise setting up

### Unit description

This series of air-water chillers and heat pumps satisfies the cooling and heating requirements of residential plants of small and medium size.

All the units are suitable for indoor installation and can be applied to fan coil plants, radiant floor plants and high efficiency radiators plants.

The refrigerant circuit, contained in a compartment protected from the air flow to simplify the maintenance operations, is equipped with scroll compressor mounted

on damper supports, brazed plate heat exchanger, thermostatic expansion valve, reverse cycle valve, centrifugal fans (plug fan), finned coil made of copper pipes and aluminium louvered fins. The circuit is protected by high and low pressure switches and differential pressure switch on the plate heat exchanger.

The plate heat exchanger and all the hydraulic pipes are thermally insulated in order to avoid condensate generation and to reduce thermal losses.

All the units are equipped with variable speed fans control that allows the units to operate with low outdoor temperatures in cooling and high outdoor temperature in heating and permits to reduce noise emissions in such operating conditions.

The low noise acoustic setting up (AS) is obtained, starting from the base setting up (AB), reducing the rotational speed of the fans and mounting sound jackets on the compressors.

All the units are supplied with an outdoor temperature sensor, already installed on the unit, in order to realize the climatic control.

All the units are provided with a phase presence and correct sequence controller device.

All the units are accurately built and individually tested in the factory. Only electric and hydraulic connections are required for installation.

### Options

#### Storing and pumping module

- not present (VB - base version)
- standard, high head or modulating pump (VP - pump version)
- tank and standard, high head or modulating pump (VA - tank version)

#### Integrative electrical heaters

- not present
- standard in the tank

#### Compressor starting

- standard (contactors)
- soft starter

#### Electrical loads protection

- fuses
- thermal magnetic circuit breakers

#### Compressor power factor correction

### Accessories

#### Rubber vibration dampers

#### Coil protection grille

#### Tank antifreeze electrical heater

#### Remote control

#### Modbus serial interface on RS485

#### Programmer clock

#### Phase sequence and voltage controller

**NET NOMINAL performances - Standard plants - EUROVENT certified data**

IR	Base setting up (AB)	19.1	22.1	26.1	30.1	35.1	40.1	
A35W7	Cooling capacity	19,9	22,1	25,8	30,8	35,6	40,2	kW
	Power input	6,82	7,50	8,76	10,8	12,3	13,9	kW
	EER	2,92	2,95	2,95	2,85	2,89	2,89	W/W
	ESEER	3,26	3,29	3,28	3,20	3,24	3,23	W/W
	Water flow rate	0,953	1,06	1,23	1,48	1,71	1,93	l/s
	Pressure drops	26	31	26	36	31	38	kPa
IR	Low noise setting up (AS)	19.1	22.1	26.1	30.1	35.1	40.1	
A35W7	Cooling capacity	19,1	21,2	24,8	29,6	34,2	38,6	kW
	Power input	7,34	8,09	9,42	11,6	13,3	15,0	kW
	EER	2,60	2,62	2,63	2,55	2,57	2,57	W/W
	ESEER	2,89	2,93	2,93	2,86	2,88	2,87	W/W
	Water flow rate	0,915	1,02	1,19	1,42	1,64	1,85	l/s
	Pressure drops	24	29	24	33	28	36	kPa
IP	Base setting up (AB)	19.1	22.1	26.1	30.1	35.1	40.1	
A35W7	Cooling capacity	19,5	21,7	25,3	30,2	34,9	39,4	kW
	Power input	6,75	7,42	8,66	10,7	12,2	13,8	kW
	EER	2,89	2,92	2,92	2,82	2,86	2,86	W/W
	ESEER	3,22	3,27	3,26	3,18	3,21	3,19	W/W
	Water flow rate	0,934	1,04	1,21	1,45	1,67	1,89	l/s
	Pressure drops	25	30	25	35	29	37	kPa
A7W45	Heating capacity	21,0	23,3	27,1	32,5	37,6	42,4	kW
	Power input	6,49	7,14	8,33	10,3	11,7	13,4	kW
	COP	3,24	3,26	3,25	3,16	3,21	3,16	W/W
	Water flow rate	0,991	1,10	1,28	1,53	1,77	2,00	l/s
	Pressure drops	27	33	27	38	33	41	kPa
IP	Low noise setting up (AS)	19.1	22.1	26.1	30.1	35.1	40.1	
A35W7	Cooling capacity	18,7	20,8	24,3	29,1	33,6	37,8	kW
	Power input	7,27	8,00	9,33	11,4	13,1	14,9	kW
	EER	2,57	2,60	2,60	2,55	2,56	2,54	W/W
	ESEER	2,86	2,89	2,89	2,83	2,84	2,84	W/W
	Water flow rate	0,896	1,00	1,16	1,39	1,61	1,81	l/s
	Pressure drops	23	28	23	32	27	34	kPa
A7W45	Heating capacity	19,9	22,2	25,8	31,0	35,8	40,3	kW
	Power input	6,22	6,85	7,98	9,88	11,3	12,8	kW
	COP	3,20	3,24	3,23	3,14	3,17	3,15	W/W
	Water flow rate	0,939	1,05	1,22	1,46	1,69	1,90	l/s
	Pressure drops	25	30	25	35	30	37	kPa

**NET NOMINAL performances - Radiant plants**

IR	Base setting up (AB)	19.1	22.1	26.1	30.1	35.1	40.1	
A35W18	Cooling capacity	24,6	27,3	31,9	38,1	44,1	49,6	kW
	Power input	7,09	7,81	9,11	11,2	12,8	14,6	kW
	EER	3,47	3,50	3,50	3,40	3,45	3,40	W/W
	Water flow rate	1,18	1,31	1,53	1,83	2,12	2,39	l/s
	Pressure drops	39	47	38	54	46	58	kPa
IP	Base setting up (AB)	19.1	22.1	26.1	30.1	35.1	40.1	
A35W18	Cooling capacity	24,2	26,8	31,3	37,4	43,2	48,7	kW
	Power input	7,01	7,73	9,01	11,1	12,7	14,4	kW
	EER	3,45	3,47	3,47	3,37	3,40	3,38	W/W
	Water flow rate	1,16	1,29	1,50	1,80	2,08	2,34	l/s
	Pressure drops	37	45	37	52	44	56	kPa
A7W35	Heating capacity	21,40	23,80	27,70	33,20	38,40	43,30	kW
	Power input	5,48	6,03	7,03	8,71	9,91	11,30	kW
	COP	3,91	3,95	3,94	3,81	3,87	3,83	W/W
	Water flow rate	1,01	1,13	1,31	1,57	1,82	2,05	l/s
	Pressure drops	29	35	29	40	34	43	kPa

Data declared according to EN 14511. The values are referred to units without options and accessories.  
**EER** (Energy Efficiency Ratio) = ratio of the total cooling capacity to the effective power input of the unit  
**COP** (Coefficient Of Performance) = ratio of the total heating capacity to the effective power input of the unit

**ESEER** (European Seasonal Energy Efficiency Ratio)  
 = Unit in **A CLASS**.

**A35W7** = source : air in 35°C d.b. / plant : water in 12°C out 7°C  
**A35W18** = source : air in 35°C d.b. / plant : water in 23°C out 18°C  
**A7W45** = source : air in 7°C d.b. 6°C w.b. / plant : water in 40°C out 45°C  
**A7W35** = source : air in 7°C d.b. 6°C w.b. / plant : water in 30°C out 35°C



### Acoustic performances

Base setting up (AB)	19.1	22.1	26.1	30.1	35.1	40.1	
Sound power level <sup>(E)</sup>	76	76	77	80	81	81	dB(A)
Sound pressure level at 1 meter	60	60	61	64	65	65	dB(A)
Sound pressure level at 5 meters	50	50	51	54	55	55	dB(A)
Sound pressure level at 10 meters	45	45	46	49	49	50	dB(A)
Low noise setting up (AS)	19.1	22.1	26.1	30.1	35.1	40.1	
Sound power level <sup>(E)</sup>	74	74	75	78	79	79	dB(A)
Sound pressure level at 1 meter	58	58	59	62	63	63	dB(A)
Sound pressure level at 5 meters	48	48	49	52	53	53	dB(A)
Sound pressure level at 10 meters	43	43	44	47	47	48	dB(A)

(E): EUROVENT certified data

The acoustic performances are referred to units operating in cooling mode at nominal conditions A35W7.

Unit placed in free field on reflecting surface (directional factor equal to 2).

The sound power level is measured according to ISO 9614 standard.

The sound pressure level is calculated according to ISO 3744 and is referred to a distance of 1/5/10 metres from the external surface of the unit.

### Technical data

Unit	19.1	22.1	26.1	30.1	35.1	40.1	
Power supply	400 - 3+N - 50						V-ph-Hz
Compressor type	scroll						-
N° compressors / N° refrigerant circuits	1 / 1						n°
Plant side heat exchanger type	stainless steel brazed plates						-
Source side heat exchanger type	finned coil						-
Fans type	centrifugal (plug fan)						-
N° fans	1						n°
Tank volume	85						l
Hydraulic fittings	1"1/4 VICTAULIC						-

### Electrical data

Standard unit	19.1	22.1	26.1	30.1	35.1	40.1	
<b>FLA</b> - Full load current at maximum tolerated conditions	28,9	30,9	33,0	28,0	32,0	36,1	A
<b>FLI</b> - Full load power input at maximum tolerated conditions	13,0	14,3	15,6	16,8	19,4	22,0	kW
<b>MIC</b> - Maximum instantaneous current of the unit	108	124	131	131	146	180	A
<b>MIC SS</b> - Maximum instantaneous current of the unit with soft starter options	65	74	78	75	84	104	A
Unit with high head modulating pump	19.1	22.1	26.1	30.1	35.1	40.1	
<b>FLA</b> - Full load current at maximum tolerated conditions	35	37	39,1	34,1	40,2	44,3	A
<b>FLI</b> - Full load power input at maximum tolerated conditions	14,2	15,5	16,8	18	21	23,6	kW
<b>MIC</b> - Maximum instantaneous current of the unit	114,1	130,1	137,1	137,1	154,2	188,2	A
<b>MIC SS</b> - Maximum instantaneous current of the unit with soft starter options	71,1	80,1	84,1	81,1	92,2	112,2	A

### Operating range

Temperatura	Unit type	Cooling		Heating		
		min	max	min	max	
Outdoor air inlet temperature	IR, BR, IP, BP	-10*	48	-15	42	(°C)
Water outlet temperature	IR, IP	5	25	30	55	(°C)
Water outlet temperature	BR, BP	-12	25	30	55	(°C)

\* with fans modulating control option (condensation / evaporation control)

### Aeraulic performances

Unit	19.1	22.1	26.1	30.1	35.1	40.1	
Available static head	150	150	150	150	150	150	Pa

## CONTROL SYSTEM

The unit is managed by a microprocessor controller to which, through a wiring board, all the electrical loads and the control devices are connected. The user interface is realized by a display and four buttons that allow to view and, if necessary, modify all the operating parameters of the unit. It's available, as an accessory, a remote control that reports all the functionalities of the user interface placed on the unit.

The main functions available are :

- water temperature management (through set point adjustment)
- adaptive function
- climatic control in heating and in cooling mode (automatic set point adjustment according to outdoor air temperature)
- dynamic defrost cycle management according to outdoor air temperature
- alarm memory management and diagnostic
- fans management by means of continuous rotational speed control

- pump management
- integrative electrical heaters management in heating mode (2 step logic)
- compressor and pump operating hours recording
- serial communication through Modbus protocol
- remote stand by
- remote cooling-heating
- general alarm digital output



## DIMENSIONS AND MINIMUM OPERATING AREA

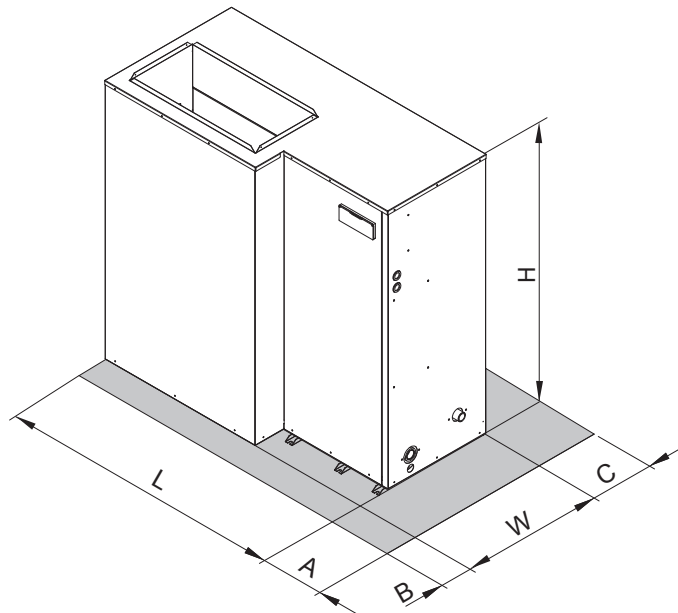

	19.1	22.1	26.1	30.1	35.1	40.1	
L		1494			1704		mm
W		744			744		mm
H		1453			1453		mm
A		400			400		mm
B		450			450		mm
C		200			200		mm
Maximum weight operation (VA Tank version)	384	387	406	408	434	436	kg

# > RMP HE

AIR-WATER CHILLERS AND HEAT PUMPS  
FOR INDOOR INSTALLATION



## Available range

### Unit type

IR	Chiller
IP	Heat pump (reversible on the refrigerant side)
BR	Chiller Brine
BP	Heat pump Brine (reversible on the refrigerant side)

### Versions

VB	Base Version
VP	Pump version
VA	Tank version

### Acoustic setting up

AB	Base setting up
AS	Low noise setting up

## Unit description

This series of air-water chillers and heat pumps satisfies the cooling and heating requirements of residential plants of small and medium size.

All the units are suitable for indoor installation and can be applied to fan coil plants, radiant floor plants and high efficiency radiators plants.

The refrigerant circuit, contained in a compartment protected from the air flow to simplify the maintenance operations, is equipped with scroll compressor mounted

on damper supports, brazed plate heat exchanger, thermostatic expansion valve, reverse cycle valve, centrifugal fans (plug fan), finned coil made of copper pipes and aluminium louvered fins. The circuit is protected by high and low pressure switches and differential pressure switch on the plate heat exchanger.

The plate heat exchanger and all the hydraulic pipes are thermally insulated in order to avoid condensate generation and to reduce thermal losses.

All the units are equipped with variable speed fans control that allows the units to operate with low outdoor temperatures in cooling and high outdoor temperature in heating and permits to reduce noise emissions in such operating conditions.

The low noise acoustic setting up (AS) is obtained, starting from the base setting up (AB), reducing the rotational speed of the fans and mounting sound jackets on the compressors.

All the units are supplied with an outdoor temperature sensor, already installed on the unit, in order to realize the climatic control.

All the units are provided with a phase presence and correct sequence controller device.

All the units are accurately built and individually tested in the factory. Only electric and hydraulic connections are required for installation.

## Options

### Storing and pumping module

- not present (VB - base version)
- standard, high head or modulating pump (VP - pump version)
- tank and standard, high head or modulating pump (VA - tank version)

### Integrative electrical heaters

- not present
- standard in the tank

### Compressor starting

- standard (contactors)
- soft starter

### Electrical loads protection

- fuses
- thermal magnetic circuit breakers

### Compressor power factor correction

## Accessories

### Rubber vibration dampers

### Coil protection grille

### Tank antifreeze electrical heater

### Remote control

### Modbus serial interface on RS485

### Programmer clock

### Phase sequence and voltage controller



**NET NOMINAL performances - Standard plants - EUROVENT certified data**

IR	Base setting up (AB)	19.1	22.1	26.1	30.1	35.1	40.1	
A35W7	Cooling capacity	20,1	22,3	26,1	31,5	36,6	41,3	kW
	Power input	6,51	7,15	8,29	10,3	11,9	13,5	kW
	EER	<b>3,09</b>	<b>3,12</b>	<b>3,15</b>	<b>3,06</b>	<b>3,08</b>	<b>3,06</b>	W/W
	ESEER	<b>3,44</b>	<b>3,48</b>	<b>3,51</b>	<b>3,44</b>	<b>3,45</b>	<b>3,45</b>	W/W
	Water flow rate	0,963	1,07	1,25	1,51	1,75	1,98	l/s
	Pressure drops	26	32	26	37	32	41	kPa
	IR	Low noise setting up (AS)	19.1	22.1	26.1	30.1	35.1	40.1
A35W7	Cooling capacity	19,3	21,4	25,1	30,3	35,2	39,8	kW
	Power input	7,02	7,71	8,94	11,1	12,8	14,4	kW
	EER	<b>2,75</b>	<b>2,78</b>	<b>2,81</b>	<b>2,73</b>	<b>2,75</b>	<b>2,76</b>	W/W
	ESEER	<b>3,06</b>	<b>3,10</b>	<b>3,12</b>	<b>3,07</b>	<b>3,08</b>	<b>3,09</b>	W/W
	Water flow rate	0,925	1,02	1,20	1,45	1,69	1,91	l/s
	Pressure drops	24	29	24	35	30	38	kPa
	IP	Base setting up (AB)	19.1	22.1	26.1	30.1	35.1	40.1
A35W7	Cooling capacity	19,7	21,9	25,6	30,9	35,9	40,5	kW
	Power input	6,45	7,08	8,20	10,2	11,8	13,4	kW
	EER	<b>3,05</b>	<b>3,09</b>	<b>3,12</b>	<b>3,03</b>	<b>3,04</b>	<b>3,02</b>	W/W
	ESEER	<b>3,40</b>	<b>3,46</b>	<b>3,47</b>	<b>3,42</b>	<b>3,40</b>	<b>3,40</b>	W/W
	Water flow rate	0,944	1,05	1,23	1,48	1,72	1,94	l/s
	Pressure drops	25	31	25	36	31	39	kPa
A7W45	Heating capacity	21,2	23,5	27,4	33,3	38,6	43,8	kW
	Power input	6,21	6,82	7,89	9,79	11,3	12,9	kW
	COP	<b>3,41</b>	<b>3,45</b>	<b>3,47</b>	<b>3,40</b>	<b>3,42</b>	<b>3,40</b>	W/W
	Water flow rate	1,00	1,11	1,29	1,57	1,82	2,06	l/s
	Pressure drops	28	34	28	40	34	43	kPa
IP	Low noise setting up (AS)	19.1	22.1	26.1	30.1	35.1	40.1	
A35W7	Cooling capacity	18,9	21,0	24,6	29,7	34,5	39,0	kW
	Power input	6,95	7,63	8,84	11,0	12,7	14,3	kW
	EER	<b>2,72</b>	<b>2,75</b>	<b>2,78</b>	<b>2,70</b>	<b>2,72</b>	<b>2,73</b>	W/W
	ESEER	<b>3,03</b>	<b>3,07</b>	<b>3,09</b>	<b>3,04</b>	<b>3,05</b>	<b>3,05</b>	W/W
	Water flow rate	0,906	1,01	1,18	1,43	1,65	1,87	l/s
	Pressure drops	23	28	23	34	29	36	kPa
A7W45	Heating capacity	20,1	22,3	26,1	31,7	36,7	41,7	kW
	Power input	5,95	6,54	7,56	9,38	10,9	12,4	kW
	COP	<b>3,38</b>	<b>3,41</b>	<b>3,45</b>	<b>3,38</b>	<b>3,37</b>	<b>3,36</b>	W/W
	Water flow rate	1,25	1,39	1,63	1,97	2,28	2,58	l/s
	Pressure drops	25	31	25	36	31	40	kPa

**NET NOMINAL performances - Radiant plants**

IR	Base setting up (AB)	19.1	22.1	26.1	30.1	35.1	40.1	
A35W18	Cooling capacity	26,1	28,9	33,9	40,8	47,4	53,5	kW
	Power input	6,67	7,35	8,49	10,6	12,2	13,9	kW
	EER	<b>3,91</b>	<b>3,93</b>	<b>3,99</b>	<b>3,85</b>	<b>3,89</b>	<b>3,85</b>	W/W
	Water flow rate	1,25	1,39	1,63	1,97	2,28	2,58	l/s
	Pressure drops	43	52	43	62	53	67	kPa
IP	Base setting up (AB)	19.1	22.1	26.1	30.1	35.1	40.1	
A35W18	Cooling capacity	25,5	28,4	33,2	40,0	46,5	52,5	kW
	Power input	6,60	7,27	8,40	10,5	12,1	13,7	kW
	EER	<b>3,86</b>	<b>3,91</b>	<b>3,95</b>	<b>3,81</b>	<b>3,84</b>	<b>3,83</b>	W/W
	Water flow rate	1,23	1,36	1,59	1,93	2,24	2,53	l/s
	Pressure drops	41	50	41	59	51	64	kPa
A7W35	Heating capacity	21,6	24,0	28,0	34,0	39,4	44,7	kW
	Power input	5,24	5,76	6,66	8,28	9,57	10,9	kW
	COP	<b>4,12</b>	<b>4,17</b>	<b>4,20</b>	<b>4,11</b>	<b>4,12</b>	<b>4,10</b>	W/W
	Water flow rate	1,02	1,14	1,33	1,61	1,87	2,11	l/s
	Pressure drops	29	36	29	42	36	46	kPa

Data declared according to EN 14511. The values are referred to units without options and accessories.

EER (Energy Efficiency Ratio) = ratio of the total cooling capacity to the effective power input of the unit

COP (Coefficient Of Performance) = ratio of the total heating capacity to the effective power input of the unit

ESEER (European Seasonal Energy Efficiency Ratio) = Unit in A CLASS.

A35W7 = source : air in 35°C d.b. / plant : water in 12°C out 7°C

A35W18 = source : air in 35°C d.b. / plant : water in 23°C out 18°C

A7W45 = source : air in 7°C d.b. 6°C w.b. / plant : water in 40°C out 45°C

A7W35 = source : air in 7°C d.b. 6°C w.b. / plant : water in 30°C out 35°C

**Acoustic performances**

Base setting up (AB)	19.1	22.1	26.1	30.1	35.1	40.1	
Sound power level <sup>(E)</sup>	76	76	77	80	81	81	dB(A)
Sound pressure level at 1 meter	60	60	61	64	65	65	dB(A)
Sound pressure level at 5 meters	50	50	51	54	55	55	dB(A)
Sound pressure level at 10 meters	45	45	46	49	49	50	dB(A)
Low noise setting up (AS)	19.1	22.1	26.1	30.1	35.1	40.1	
Sound power level <sup>(E)</sup>	74	74	75	78	79	79	dB(A)
Sound pressure level at 1 meter	58	58	59	62	63	63	dB(A)
Sound pressure level at 5 meters	48	48	49	52	53	53	dB(A)
Sound pressure level at 10 meters	43	43	44	47	47	48	dB(A)

(E): EUROVENT certified data

The acoustic performances are referred to units operating in cooling mode at nominal conditions A35W7.

Unit placed in free field on reflecting surface (directional factor equal to 2).

The sound power level is measured according to ISO 9614 standard.

The sound pressure level is calculated according to ISO 3744 and is referred to a distance of 1/5/10 metres from the external surface of the unit.

**Technical data**

Unit	19.1	22.1	26.1	30.1	35.1	40.1	
Power supply	400 - 3+N - 50						V-ph-Hz
Compressor type	scroll						-
N° compressors / N° refrigerant circuits	1 / 1						n°
Plant side heat exchanger type	stainless steel brazed plates						-
Source side heat exchanger type	finned coil						-
Fans type	centrifugal (plug fan)						-
N° fans	1						n°
Tank volume	85						l
Hydraulic fittings	1"1/4 VICTAULIC						-

**Electrical data**

Standard unit	19.1	22.1	26.1	30.1	35.1	40.1	
<b>FLA</b> - Full load current at maximum tolerated conditions	28,9	30,9	33,0	28,0	32,0	36,1	A
<b>FLI</b> - Full load power input at maximum tolerated conditions	13,0	14,3	15,6	16,8	19,4	22,0	kW
<b>MIC</b> - Maximum instantaneous current of the unit	108	124	131	131	146	180	A
<b>MIC SS</b> - Maximum instantaneous current of the unit with soft starter options	65	74	78	75	84	104	A
Unit with high head modulating pump	19.1	22.1	26.1	30.1	35.1	40.1	
<b>FLA</b> - Full load current at maximum tolerated conditions	35	37	39,1	34,1	40,2	44,3	A
<b>FLI</b> - Full load power input at maximum tolerated conditions	14,2	15,5	16,8	18	21	23,6	kW
<b>MIC</b> - Maximum instantaneous current of the unit	114,1	130,1	137,1	137,1	154,2	188,2	A
<b>MIC SS</b> - Maximum instantaneous current of the unit with soft starter options	71,1	80,1	84,1	81,1	92,2	112,2	A

**Operating range**

Temperatura	Unit type	Cooling		Heating		
		min	max	min	max	
Outdoor air inlet temperature	IR, BR, IP, BP	-10*	48	-15	42	(°C)
Water outlet temperature	IR, IP	5	25	30	55	(°C)
Water outlet temperature	BR, BP	-12	25	30	55	(°C)

\* with fans modulating control option (condensation / evaporation control)

**Aeraulic performances**

Unit	19.1	22.1	26.1	30.1	35.1	40.1	
Available static head	150	150	150	150	150	150	Pa

## CONTROL SYSTEM

The unit is managed by a microprocessor controller to which, through a wiring board, all the electrical loads and the control devices are connected. The user interface is realized by a display and four buttons that allow to view and, if necessary, modify all the operating parameters of the unit. It's available, as an accessory, a remote control that reports all the functionalities of the user interface placed on the unit.

The main functions available are :

- water temperature management (through set point adjustment)
- adaptive function
- climatic control in heating and in cooling mode (automatic set point adjustment according to outdoor air temperature)
- dynamic defrost cycle management according to outdoor air temperature
- alarm memory management and diagnostic
- fans management by means of continuous rotational speed control

- pump management
- integrative electrical heaters management in heating mode (2 step logic)
- compressor and pump operating hours recording
- serial communication through Modbus protocol
- remote stand by
- remote cooling-heating
- general alarm digital output



## DIMENSIONS AND MINIMUM OPERATING AREA

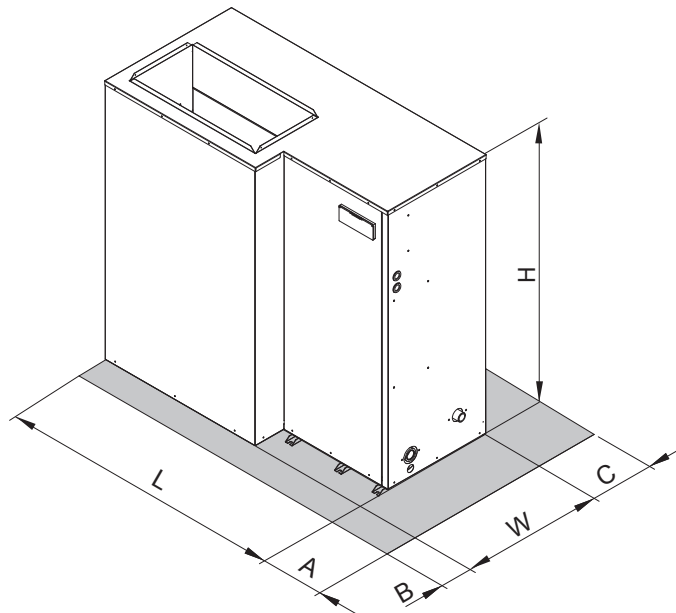

	19.1	22.1	26.1	30.1	35.1	40.1	
L		1494			1704		mm
W		744			744		mm
H		1453			1453		mm
A		400			400		mm
B		450			450		mm
C		200			200		mm
Maximum weight operation (VA Tank version)	399	402	426	433	459	461	kg



# > RGC

## AIR-WATER CHILLERS AND HEAT PUMPS FOR INDOOR INSTALLATION

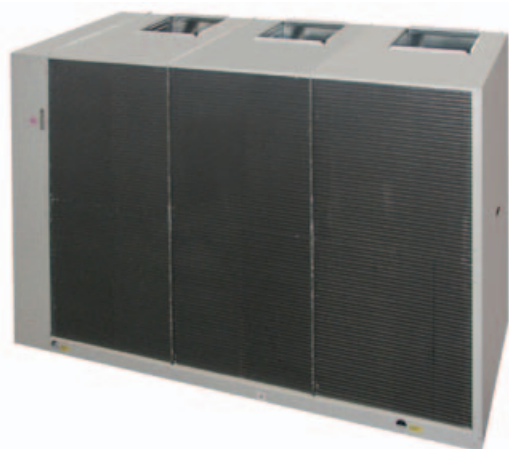

### Available range

#### Unit type

IR	Chiller
IP	Heat pump (reversible on the refrigerant side)
BR	Chiller Brine
BP	Heat pump Brine (reversible on the refrigerant side)

#### Version

VB	Base version
VD	Desuperheater version
VR	Total recovery version

#### Acoustic setting up

AB	Base setting up
AS	Low noise setting up

#### Source temperature level

M	Medium temperature level
A	High temperature level

### Unit description

This series of air-water chillers and heat pumps satisfies the cooling and heating requirements of residential plants of medium size.

All the units are suitable for indoor installation and can be applied to fan coil plants, radiant floor plants and high efficiency radiators plants.

The refrigerant circuit, contained in a compartment protected from the air flow to simplify the maintenance operations, is equipped with scroll compressors mounted on damper supports, brazed plate heat exchanger, thermostatic expansion valve (standard for IR) or electronic expansion valve (standard for IP / option for IR), reverse cycle valve, dehydrator fil-

ter, double inlet centrifugal fans with forward curved blades, finned coil made of copper pipes and aluminium louvered fins with subcooling section. The circuit is protected by a safety gas valve, high and low pressure switches and differential pressure switch on the plate heat exchanger. The plate heat exchanger and all the hydraulic pipes are thermally insulated in order to avoid condensate generation and to reduce thermal losses.

All the units can be equipped with variable speed fans control that allows the units to operate with low outdoor temperatures in cooling and high outdoor temperature in heating and permits to reduce noise emissions in such operating conditions.

The low noise acoustic setting up (AS) is obtained, starting from the base setting up (AB), mounting sound jackets on the compressors and the technical compartment is clad with soundproofing material of suitable thickness.

All the units are supplied with a management and control electrical panel containing general switch, phase presence and correct sequence controller, microprocessor controller with display and all the other electrical components with IP54 minimum protection degree.

All the units are accurately built and individually tested in the factory. Only electric and hydraulic connections are required for installation.

### Options

**Storing and pumping module** available in the configurations :

- Storage tank arranged as buffer on the flow or as primary-secondary buffer
- 1 or 2 pumps
- standard or high head pump
- modulating pump

#### Expansion valve

- thermostatic
- electronic (standard for IP)

#### Compressor starting

- standard (contactors)
- soft starter

#### Fans control

- on-off control
- modulating control (condensation / evaporation control)

#### Compressor power factor correction

#### Electrical load protection

- fuses
- thermal magnetic circuit breakers

#### Coil condensate tray

(standard for IP)

### Accessories

Rubber vibration dampers

Spring vibration dampers

Coil protection grilles

Tank antifreeze electrical heater

Remote control

Modbus serial interface on RS485

Programmer clock

Phase sequence and voltage controller

Low temperature kit (standard for IP)

High and low pressure gauges

High temperature thermostat

Coil shut off valves

Outdoor air sensor

Water flow switch

Victaulic hydraulic fittings

**NET NOMINAL performances - Standard plants - EUROVENT certified data**

IR	Base setting up (AB)	40.2	50.2	60.2	70.2	80.2	90.2	100.2	115.2	130.2	145.2	160.2	180.2	200.2	
A35W7	Cooling capacity	45,0	53,0	58,1	68,2	78,1	90,3	101	111	125	142	157	179	198	kW
	Power input	15,7	18,8	20,8	24,1	28,0	32,5	35,9	39,9	45,1	51,5	57,1	64,6	71,6	kW
	EER	2,87	2,82	2,79	2,83	2,79	2,78	2,81	2,78	2,77	2,76	2,75	2,77	2,77	W/W
	ESEER	3,93	3,90	3,85	3,91	3,84	3,93	3,86	3,93	3,82	3,89	3,77	3,80	3,82	W/W
	Water flow rate	2,16	2,56	2,80	3,29	3,76	4,35	4,87	5,35	6,02	6,83	7,55	8,60	9,56	l/s
	Pressure drops	40	56	55	51	50	48	46	44	48	47	48	48	50	kPa
IR	Low noise setting up (AS)	40.2	50.2	60.2	70.2	80.2	90.2	100.2	115.2	130.2	145.2	160.2	180.2	200.2	
A35W7	Cooling capacity	45,0	53,0	58,1	68,2	78,1	90,3	101	111	125	142	157	179	198	kW
	Power input	15,7	18,8	20,8	24,1	28,0	32,5	35,9	39,9	45,1	51,5	57,1	64,6	71,6	kW
	EER	2,87	2,82	2,79	2,83	2,79	2,78	2,81	2,78	2,77	2,76	2,75	2,77	2,77	W/W
	ESEER	3,93	3,90	3,85	3,91	3,84	3,93	3,86	3,93	3,82	3,89	3,77	3,80	3,82	W/W
	Water flow rate	2,16	2,56	2,80	3,29	3,76	4,35	4,87	5,35	6,02	6,83	7,55	8,60	9,56	l/s
	Pressure drops	40	56	55	51	50	48	46	44	48	47	48	48	50	kPa
IP	Base setting up (AB)	40.2	50.2	60.2	70.2	80.2	90.2	100.2	115.2	130.2	145.2	160.2	180.2	200.2	
A35W7	Cooling capacity	43,5	52,4	57,0	66,7	73,6	88,5	98	109	121	137	153	177	196	kW
	Power input	15,5	19,0	20,7	24,1	27,0	32,3	35,7	39,8	44,5	50,3	56,3	63,5	71,2	kW
	EER	2,81	2,76	2,75	2,77	2,73	2,74	2,75	2,74	2,72	2,72	2,72	2,79	2,75	W/W
	ESEER	3,84	3,82	3,80	3,80	3,73	3,87	3,78	3,87	3,73	3,84	3,72	3,82	3,79	W/W
	Water flow rate	2,09	2,53	2,75	3,21	3,54	4,26	4,73	5,26	5,83	6,59	7,36	8,50	9,46	l/s
	Pressure drops	37	55	53	49	44	46	43	43	45	44	46	47	49	kPa
A7W45	Heating capacity	48,1	58,1	63,2	74,5	83,0	99,6	110	125	136	154	173	197	216	kW
	Power input	15,6	19,1	20,9	24,4	27,6	33,5	35,9	41,1	44,9	51,8	56,9	65,1	71,7	kW
	COP	3,08	3,04	3,02	3,05	3,01	2,97	3,06	3,04	3,03	2,97	3,04	3,03	3,01	W/W
	Water flow rate	2,28	2,75	2,99	3,53	3,93	4,72	5,21	5,92	6,45	7,31	8,17	9,32	10,2	l/s
	Pressure drops	45	65	63	59	55	57	53	54	55	54	56	57	57	kPa
IP	Low noise setting up (AS)	40.2	50.2	60.2	70.2	80.2	90.2	100.2	115.2	130.2	145.2	160.2	180.2	200.2	
A35W7	Cooling capacity	43,5	52,4	57,0	66,7	73,6	88,5	98	109	121	137	153	177	196	kW
	Power input	15,5	19,0	20,7	24,1	27,0	32,3	35,7	39,8	44,5	50,3	56,3	63,5	71,2	kW
	EER	2,81	2,76	2,75	2,77	2,73	2,74	2,75	2,74	2,72	2,72	2,72	2,79	2,75	W/W
	ESEER	3,84	3,82	3,80	3,80	3,73	3,87	3,78	3,87	3,73	3,84	3,72	3,82	3,79	W/W
	Water flow rate	2,09	2,53	2,75	3,21	3,54	4,26	4,73	5,26	5,83	6,59	7,36	8,50	9,46	l/s
	Pressure drops	37	55	53	49	44	46	43	43	45	44	46	47	49	kPa
A7W45	Heating capacity	48,1	58,1	63,2	74,5	83,0	99,6	110	125	136	154	173	197	216	kW
	Power input	15,6	19,1	20,9	24,4	27,6	33,5	35,9	41,1	44,9	51,8	56,9	65,1	71,7	kW
	COP	3,08	3,04	3,02	3,05	3,01	2,97	3,06	3,04	3,03	2,97	3,04	3,03	3,01	W/W
	Water flow rate	2,28	2,75	2,99	3,53	3,93	4,72	5,21	5,92	6,45	7,31	8,17	9,32	10,2	l/s
	Pressure drops	45	65	63	59	55	57	53	54	55	54	56	57	57	kPa

Data declared according to EN 14511. The values are referred to units without options and accessories.  
**EER** (Energy Efficiency Ratio) = ratio of the total cooling capacity to the effective power input of the unit  
**COP** (Coefficient Of Performance) = ratio of the total heating capacity to the effective power input of the unit

**ESEER** (European Seasonal Energy Efficiency Ratio)  
 = Unit in **A CLASS**.  
**A35W7** = source : air in 35°C d.b. / plant : water in 12°C out 7°C  
**A35W18** = source : air in 35°C d.b. / plant : water in 23°C out 18°C  
**A7W45** = source : air in 7°C d.b. 6°C w.b. / plant : water in 40°C out 45°C  
**A7W35** = source : air in 7°C d.b. 6°C w.b. / plant : water in 30°C out 35°C

**Acoustic performances**

Base setting up (AB)	40.2	50.2	60.2	70.2	80.2	90.2	100.2	115.2	130.2	145.2	160.2	180.2	200.2	
Sound power level <sup>(E)</sup>	88	88	89	89	89	91	91	91	96	97	97	98	98	dB(A)
Sound pressure level at 1 meter	70	70	71	71	71	73	73	73	78	79	79	80	80	dB(A)
Sound pressure level at 5 meters	61	61	62	62	62	65	65	65	69	70	70	71	71	dB(A)
Sound pressure level at 10 meters	56	56	57	57	57	59	59	59	64	65	65	66	66	dB(A)
Low noise setting up (AS)	40.2	50.2	60.2	70.2	80.2	90.2	100.2	115.2	130.2	145.2	160.2	180.2	200.2	
Sound power level <sup>(E)</sup>	85	85	86	86	86	88	88	88	93	94	94	95	95	dB(A)
Sound pressure level at 1 meter	67	67	68	68	68	70	70	70	75	76	76	77	77	dB(A)
Sound pressure level at 5 meters	58	58	59	59	59	62	62	62	66	67	67	68	68	dB(A)
Sound pressure level at 10 meters	53	53	54	54	54	56	56	56	61	62	62	63	63	dB(A)

**(E): EUROVENT certified data**

The acoustic performances are referred to units operating in cooling mode at nominal conditions A35W7.

Unit placed in free field on reflecting surface (directional factor equal to 2).

The sound power level is measured according to ISO 9614 standard.

The sound pressure level is calculated according to ISO 3744 and is referred to a distance of 1/5/10 metres from the external surface of the unit.

**Technical data**

Unit	40.2	50.2	60.2	70.2	80.2	90.2	100.2	115.2	130.2	145.2	160.2	180.2	200.2	
Power supply	400 - 3 - 50													V-ph-Hz
Compressor type	scroll													-
N° compressors / N° refrigerant circuits	2 / 1													n°
Plant side heat exchanger type	stainless steel brazed plates													-
Source side heat exchanger type	finned coil													-
Fans type	centrifugal													-
N° fans	1			2			3			4			n°	
Tank volume	200			400			460						l	
Hydraulic fittings	2" VICTAULIC						2" 1/2 VICTAULIC						-	

**Electrical data**

Standard unit	40.2	50.2	60.2	70.2	80.2	90.2	100.2	115.2	130.2	145.2	160.2	180.2	200.2	
<b>FLA</b> - Full load current at maximum tolerated conditions	43,2	48,8	56,7	62,1	73,0	80,5	95,0	103	117	145	158	188	199	A
<b>FLI</b> - Full load power input at maximum tolerated conditions	25,2	28,0	33,0	35,6	40,8	47,3	58,3	63,8	72,8	88,7	96,3	113	120	kW
<b>MIC</b> - Maximum instantaneous current of the unit	137	147	152	177	216	269	264	272	278	370	383	384	420	A
<b>MIC SS</b> - Maximum instantaneous current of the unit with soft starter options	92,4	99,4	105	121	147	179	180	188	194	222	268	277	301	A
Unit with high head modulating pump	40.2	50.2	60.2	70.2	80.2	90.2	100.2	115.2	130.2	145.2	160.2	180.2	200.2	
<b>FLA</b> - Full load current at maximum tolerated conditions	49,3	54,9	62,8	68,2	79,1	86,6	101	112	126	153	166	198	209	A
<b>FLI</b> - Full load power input at maximum tolerated conditions	28,7	31,5	36,5	39,1	44,3	50,8	61,8	68,4	77,3	93,2	101	119	126	kW
<b>MIC</b> - Maximum instantaneous current of the unit	143	153	158	183	222	275	270	281	287	378	392	394	430	A
<b>MIC SS</b> - Maximum instantaneous current of the unit with soft starter options	98,5	105	111	127	153	185	186	197	203	231	277	287	311	A

**Operative range**

Temperature	Unit type	Cooling		Heating		
		min	max	min	max	
Outdoor air inlet temperature	IR, BR, IP, BP	-10*	50	-10	40*	(°C)
Water outlet temperature	IR, IP	5	25	30	55	(°C)
Water outlet temperature	BR, BP	-12	25	30	55	(°C)
Water outlet temperature (VD)	IR, BR, IP, BP	30	70	30	70	(°C)
Water outlet temperature (VR)	IR, BR	30	55	-	-	(°C)

\* with fans modulating control option (condensation / evaporation control)

**Aeraulic performance**

Unit	40.2	50.2	60.2	70.2	80.2	90.2	100.2	115.2	130.2	145.2	160.2	180.2	200.2	
Available static head	150	150	150	150	150	150	150	150	150	150	150	150	150	Pa

## VD and VR versions

These units allow to recover the heating power, otherwise wasted on air, through an additional heat exchanger.

The **Desuperheater Version (VD)** allow the hot water production at temperatures between 30 and 70°C through the partial heat recovery of the condensation heat.

The **Total Recovery Version (VR)** allows the cold water production and, at the same time, the hot water production at temperatures between 30 and 55°C through the total recovery of the condensation heat.

### Desupeheater Version (VD) - NET NOMINAL performances

IR	Base setting up (AB)	40.2	50.2	60.2	70.2	80.2	90.2	100.2	115.2	130.2	145.2	160.2	180.2	200.2	
A35W7 - W45	Cooling capacity	46,8	55,1	60,3	71	81,1	93,8	105	115	130	148	163	185	206	kW
	Total power input	15,3	18,3	20,3	23,4	27,3	31,8	35,1	38,9	44	50,3	55,8	63	69,9	kW
	EER	<b>3,05</b>	<b>3</b>	<b>2,98</b>	<b>3,03</b>	<b>2,97</b>	<b>2,95</b>	<b>2,99</b>	<b>2,96</b>	<b>2,95</b>	<b>2,94</b>	<b>2,92</b>	<b>2,94</b>	<b>2,95</b>	W/W
	HRE	<b>3,93</b>	<b>3,86</b>	<b>3,84</b>	<b>3,88</b>	<b>3,83</b>	<b>3,8</b>	<b>3,86</b>	<b>3,85</b>	<b>3,83</b>	<b>3,81</b>	<b>3,8</b>	<b>3,82</b>	<b>3,83</b>	W/W
	Water flow rate	2,25	2,66	2,91	3,42	3,91	4,52	5,06	5,54	6,26	7,12	7,84	8,93	9,94	l/s
	Water pressure drop	43	60	59	55	54	52	50	47	52	51	52	52	54	kPa
	Heating recovery capacity	13,5	15,7	17,6	20	23,6	27,1	30,4	34,4	38,4	44	49,3	55,4	61,3	kW
	Water flow rate recovery	0,65	0,75	0,84	0,96	1,13	1,29	1,45	1,64	1,83	2,1	2,36	2,65	2,93	l/s
	Water pressure drop recovery	6	9	11	14	19	15	18	11	14	18	22	18	21	kPa
	IP	Base setting up (AB)	40.2	50.2	60.2	70.2	80.2	90.2	100.2	115.2	130.2	145.2	160.2	180.2	200.2
A35W7 - W45	Cooling capacity	45,3	54,5	59,3	69,3	76,5	92,1	102	113	126	143	159	183	204	kW
	Total power input	15,1	18,5	20,1	23,5	26,4	31,5	34,9	38,7	43,4	49,1	54,9	62,1	69,5	kW
	EER	<b>3</b>	<b>2,94</b>	<b>2,94</b>	<b>2,95</b>	<b>2,9</b>	<b>2,92</b>	<b>2,93</b>	<b>2,92</b>	<b>2,9</b>	<b>2,91</b>	<b>2,89</b>	<b>2,95</b>	<b>2,94</b>	W/W
	HRE	<b>3,86</b>	<b>3,76</b>	<b>3,79</b>	<b>3,78</b>	<b>3,77</b>	<b>3,75</b>	<b>3,77</b>	<b>3,78</b>	<b>3,76</b>	<b>3,77</b>	<b>3,75</b>	<b>3,8</b>	<b>3,77</b>	W/W
	Water flow rate	2,18	2,63	2,86	3,34	3,68	4,43	4,92	5,45	6,07	6,88	7,64	8,84	9,84	l/s
	Water pressure drop	41	59	57	53	48	50	47	46	49	48	49	51	53	kPa
	Heating recovery capacity	13	15,2	17	19,4	22,9	26,2	29,2	33,2	37,1	42,4	47,5	52,4	58,1	kW
	Water flow rate recovery	0,62	0,73	0,81	0,93	1,09	1,25	1,4	1,59	1,77	2,03	2,27	2,5	2,78	l/s
	Water pressure drop recovery	6	8	10	13	18	14	17	10	13	17	21	16	19	kPa

### Total Recovery Version (VR) - NET NOMINAL performances

IR	Base setting up (AB)	40.2	50.2	60.2	70.2	80.2	90.2	100.2	115.2	130.2	145.2	160.2	180.2	200.2	
A35W7 - W45	Cooling capacity	46,8	55,1	60,3	71	81,1	93,8	105	115	130	148	163	185	206	kW
	Total power input	13,9	16,9	18,4	21,4	25,3	27,9	31,1	35	40	44,4	49,9	55,3	62,1	kW
	EER	<b>3,36</b>	<b>3,25</b>	<b>3,28</b>	<b>3,31</b>	<b>3,2</b>	<b>3,36</b>	<b>3,38</b>	<b>3,29</b>	<b>3,25</b>	<b>3,33</b>	<b>3,26</b>	<b>3,35</b>	<b>3,32</b>	W/W
	HRE	<b>7,67</b>	<b>7,46</b>	<b>7,52</b>	<b>7,58</b>	<b>7,35</b>	<b>7,67</b>	<b>7,71</b>	<b>7,52</b>	<b>7,45</b>	<b>7,61</b>	<b>7,47</b>	<b>7,65</b>	<b>7,59</b>	W/W
	Water flow rate	2,25	2,66	2,91	3,42	3,91	4,52	5,06	5,54	6,26	7,12	7,84	8,93	9,94	l/s
	Water pressure drop	43	60	59	55	54	52	50	47	52	51	52	52	54	kPa
	Heating recovery capacity	60	71,2	77,8	91,4	105	120	135	148	168	190	210	238	265	kW
	Water flow rate recovery	2,87	3,4	3,72	4,37	5,02	5,73	6,45	7,07	8,03	9,08	10	11,4	12,7	l/s
	Water pressure drop recovery	35	49	41	45	50	48	52	47	52	51	52	55	55	kPa

Data declared according to EN 14511. The values are referred to units without options and accessories.

EER (Energy Efficiency Ratio) = ratio of the total cooling capacity to the effective power input of the unit

HRE (Heat Recovery Efficiency) = ratio of the total capacity of the system (heating plus cooling capacity) to the effective power input

A35W7 - W45 = source : air in 35°C d.b. / plant : water in 12°C out 7°C / Recovery : water in 40°C out 45°C

## CONTROL SYSTEM

The units are equipped with a controller designed to ensure energy saving and unit efficiency. Available functions :

- Adaptive function
- Dynamic defrost
- Sound management
- Climatic control in heating and in cooling mode
- Economy function
- Demand limit
- Integrative heating
- Remote stand by
- Remote cooling-heating



## DIMENSIONS - MINIMUM OPERATING AREA - WEIGHT

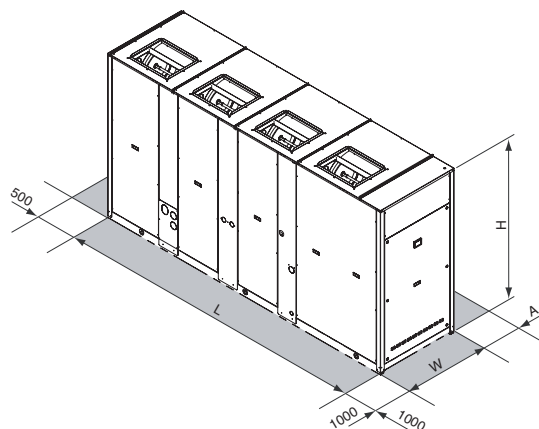

	40.2	50.2	60.2	70.2	80.2	90.2	100.2	115.2	130.2	145.2	160.2	180.2	200.2	
L			2501				3343			3343		4097		mm
W			954				1104			1104		1104		mm
H			1760				1760			2160		2160		mm
A				1600							2000			mm
Operating maximum weight*	1078	1082	1102	1143	1168	1684	1765	1825	2000	2042	2094	2423	2467	kg

\* Weight refers to the unit IP with tank and pumping module 2 pumps.



# > RGC HE

## AIR-WATER CHILLERS AND HEAT PUMPS FOR INDOOR INSTALLATION



### Available range

#### Unit type

IR	Chiller
IP	Heat pump (reversible on the refrigerant side)
BR	Chiller Brine
BP	Heat pump Brine (reversible on the refrigerant side)

#### Version

VB	Base version
VD	Desuperheater version
VR	Total recovery version

#### Acoustic setting up

AB	Base setting up
AS	Low noise setting up

#### Source temperature level

M	Medium temperature level
A	High temperature level

### Unit description

This series of air-water chillers and heat pumps satisfies the cooling and heating requirements of residential plants of medium size.

All the units are suitable for indoor installation and can be applied to fan coil plants, radiant floor plants and high efficiency radiators plants.

The refrigerant circuit, contained in a compartment protected from the air flow to simplify the maintenance operations, is equipped with scroll compressors mounted on damper supports, brazed plate heat exchanger, thermostatic expansion valve (standard for IR) or electronic expansion valve (standard for IP / option for IR), reverse cycle valve, dehydrator fil-

ter, double inlet centrifugal fans with forward curved blades, finned coil made of copper pipes and aluminium louvered fins with subcooling section. The circuit is protected by a safety gas valve, high and low pressure switches and differential pressure switch on the plate heat exchanger. The plate heat exchanger and all the hydraulic pipes are thermally insulated in order to avoid condensate generation and to reduce thermal losses.

All the units can be equipped with variable speed fans control that allows the units to operate with low outdoor temperatures in cooling and high outdoor temperature in heating and permits to reduce noise emissions in such operating conditions.

The low noise acoustic setting up (AS) is obtained, starting from the base setting up (AB), mounting sound jackets on the compressors and the technical compartment is clad with soundproofing material of suitable thickness.

All the units are supplied with a management and control electrical panel containing general switch, phase presence and correct sequence controller, microprocessor controller with display and all the other electrical components with IP54 minimum protection degree.

All the units are accurately built and individually tested in the factory. Only electric and hydraulic connections are required for installation.

### Options

Storing and pumping module available in the configurations :

- Storage tank arranged as buffer on the flow or as primary-secondary buffer
- 1 or 2 pumps
- standard or high head pump
- modulating pump

#### Expansion valve

- thermostatic
- electronic (standard for IP)

#### Compressor starting

- standard (contactors)
- soft starter

#### Fans control

- on-off control
- modulating control (condensation / evaporation control)

#### Compressor power factor correction

#### Electrical load protection

- fuses
- thermal magnetic circuit breakers

#### Coil condensate tray

(standard for IP)

### Accessories

Rubber vibration dampers

Spring vibration dampers

Coil protection grilles

Tank antifreeze electrical heater

Remote control

Modbus serial interface on RS485

Programmer clock

Phase sequence and voltage controller

Low temperature kit (standard for IP)

High and low pressure gauges

High temperature thermostat

Coil shut off valves

Outdoor air sensor

Water flow switch

Victaulic hydraulic fittings

**NET NOMINAL performances - Standard plants - EUROVENT certified data**

IR	Base setting up (AB)	40.2	50.2	60.2	70.2	80.2	90.2	100.2	115.2	130.2	145.2	160.2	180.2		
A35W7	Cooling capacity	47,2	55,9	63,1	70,5	83,4	94,9	106	120	133	153	173	197	kW	
	Power input	14,9	17,2	19,8	22,1	27,2	31,2	34,6	38,6	42,7	50,0	55,5	64,6	kW	
	EER	3,17	3,25	3,19	3,19	3,07	3,04	3,06	3,11	3,11	3,06	3,12	3,05	W/W	
	ESEER	4,31	4,44	4,34	4,39	4,17	4,27	4,20	4,37	4,26	4,31	4,27	4,16	W/W	
	Water flow rate	2,26	2,69	3,03	3,39	4,00	4,56	5,11	5,78	6,40	7,36	8,31	9,46	l/s	
	Pressure drops	24	34	33	41	31	32	34	33	35	35	38	39	kPa	
IR	Low noise setting up (AS)	40.2	50.2	60.2	70.2	80.2	90.2	100.2	115.2	130.2	145.2	160.2	180.2		
A35W7	Cooling capacity	47,2	55,9	63,1	70,5	83,4	94,9	106	120	133	153	173	197	kW	
	Power input	14,9	17,2	19,8	22,1	27,2	31,2	34,6	38,6	42,7	50,0	55,5	64,6	kW	
	EER	3,17	3,25	3,19	3,19	3,07	3,04	3,06	3,11	3,11	3,06	3,12	3,05	W/W	
	ESEER	4,31	4,44	4,34	4,39	4,17	4,27	4,20	4,37	4,26	4,31	4,27	4,16	W/W	
	Water flow rate	2,26	2,69	3,03	3,39	4,00	4,56	5,11	5,78	6,40	7,36	8,31	9,46	l/s	
	Pressure drops	24	34	33	41	31	32	34	33	35	35	38	39	kPa	
IP	Base setting up (AB)	40.2	50.2	60.2	70.2	80.2	90.2	100.2	115.2	130.2	145.2	160.2	180.2		
A35W7	Cooling capacity	45,3	53,6	60,7	67,8	81,3	92,4	103	115	128	147	166	191	kW	
	Power input	14,6	17,1	19,4	21,7	26,7	30,2	33,8	37,8	41,8	48,5	54,3	62,8	kW	
	EER	3,10	3,13	3,13	3,12	3,04	3,06	3,05	3,04	3,06	3,03	3,06	3,04	W/W	
	ESEER	4,22	4,29	4,27	4,28	4,15	4,28	4,16	4,28	4,19	4,26	4,17	4,15	W/W	
	Water flow rate	2,17	2,58	2,91	3,26	3,90	4,43	4,97	5,54	6,16	7,07	7,98	9,17	l/s	
	Pressure drops	22	31	30	38	29	30	32	30	32	32	35	37	kPa	
A7W45	Heating capacity	49,4	58,3	66,0	74,1	88,4	100	113	126	141	161	181	207	kW	
	Power input	15,5	18,1	20,8	23,4	27,9	31,6	35,5	39,7	44,3	51,0	57,1	65,6	kW	
	COP	3,19	3,22	3,17	3,17	3,17	3,16	3,18	3,17	3,18	3,16	3,17	3,16	W/W	
	Water flow rate	2,35	2,77	3,13	3,52	4,20	4,77	5,35	5,97	6,69	7,64	8,60	9,84	l/s	
A7W45	Pressure drops	26	36	35	44	34	35	37	35	38	38	41	42	kPa	
	IP	Low noise setting up (AS)	40.2	50.2	60.2	70.2	80.2	90.2	100.2	115.2	130.2	145.2	160.2	180.2	
	A35W7	Cooling capacity	45,3	53,6	60,7	67,8	81,3	92,4	103	115	128	147	166	191	kW
		Power input	14,6	17,1	19,4	21,7	26,7	30,2	33,8	37,8	41,8	48,5	54,3	62,8	kW
EER		3,10	3,13	3,13	3,12	3,04	3,06	3,05	3,04	3,06	3,03	3,06	3,04	W/W	
ESEER		4,22	4,29	4,27	4,28	4,15	4,28	4,16	4,28	4,19	4,26	4,17	4,15	W/W	
Water flow rate		2,17	2,58	2,91	3,26	3,90	4,43	4,97	5,54	6,16	7,07	7,98	9,17	l/s	
Pressure drops		22	31	30	38	29	30	32	30	32	32	35	37	kPa	
A7W45	Heating capacity	49,4	58,3	66,0	74,1	88,4	100	113	126	141	161	181	207	kW	
	Power input	15,5	18,1	20,8	23,4	27,9	31,6	35,5	39,7	44,3	51,0	57,1	65,6	kW	
	COP	3,19	3,22	3,17	3,17	3,17	3,16	3,18	3,17	3,18	3,16	3,17	3,16	W/W	
	Water flow rate	2,35	2,77	3,13	3,52	4,20	4,77	5,35	5,97	6,69	7,64	8,60	9,84	l/s	
A7W45	Pressure drops	26	36	35	44	34	35	37	35	38	38	41	42	kPa	

**NET NOMINAL performances - Radiant plants**

IR	Base setting up (AB)	40.2	50.2	60.2	70.2	80.2	90.2	100.2	115.2	130.2	145.2	160.2	180.2	
A35W18	Cooling capacity	61,2	72,4	81,7	91,3	108	123	138	156	172	198	224	254	kW
	Power input	16,2	18,9	21,6	24,2	29,6	34,0	37,7	42,2	46,7	54,5	60,6	70,6	kW
	EER	3,78	3,83	3,78	3,77	3,65	3,62	3,66	3,70	3,68	3,63	3,70	3,60	W/W
	Water flow rate	2,94	3,49	3,94	4,41	5,21	5,92	6,64	7,50	8,31	9,56	10,8	12,3	l/s
	Pressure drops	41	57	56	69	53	54	57	56	59	59	64	66	kPa
IP	Base setting up (AB)	40.2	50.2	60.2	70.2	80.2	90.2	100.2	115.2	130.2	145.2	160.2	180.2	
A35W18	Cooling capacity	58,8	69,5	78,6	87,8	105	120	134	150	167	190	215	248	kW
	Power input	15,9	18,6	21,2	23,8	28,9	32,9	36,9	41,1	45,6	52,8	59,3	68,6	kW
	EER	3,70	3,74	3,71	3,69	3,63	3,65	3,63	3,65	3,66	3,60	3,63	3,62	W/W
	Water flow rate	2,83	3,35	3,79	4,24	5,06	5,78	6,45	7,21	8,03	9,17	10,40	11,9	l/s
	Pressure drops	38	53	52	64	50	51	54	51	55	54	60	62	kPa
A7W35	Heating capacity	52,4	61,9	69,9	78,6	93,8	107	120	134	149	171	192	220	kW
	Power input	12,7	14,9	17,1	19,3	23,2	26,2	29,4	32,7	36,5	42,3	47,2	54,4	kW
	COP	4,13	4,15	4,09	4,07	4,04	4,08	4,08	4,10	4,08	4,04	4,07	4,04	W/W
	Water flow rate	2,49	2,94	3,32	3,73	4,45	5,06	5,69	6,35	7,07	8,12	9,13	10,4	l/s
A7W35	Pressure drops	29	41	40	50	38	39	42	40	43	43	46	47	kPa

Data declared according to EN 14511. The values are referred to units without options and accessories.

EER (Energy Efficiency Ratio) = ratio of the total cooling capacity to the effective power input of the unit

COP (Coefficient Of Performance) = ratio of the total heating capacity to the effective power input of the unit

ESEER (European Seasonal Energy Efficiency Ratio)

\_\_\_\_\_ = Unit in A CLASS.

A35W7 = source : air in 35°C d.b. / plant : water in 12°C out 7°C

A35W18 = source : air in 35°C d.b. / plant : water in 23°C out 18°C

A7W45 = source : air in 7°C d.b. 6°C w.b. / plant : water in 40°C out 45°C

A7W35 = source : air in 7°C d.b. 6°C w.b. / plant : water in 30°C out 35°C

**Acoustic performances**

Base setting up (AB)	40.2	50.2	60.2	70.2	80.2	90.2	100.2	115.2	130.2	145.2	160.2	180.2	
Sound power level <sup>(E)</sup>	88	88	89	89	91	91	91	96	96	97	97	98	dB(A)
Sound pressure level at 1 meter	70	70	71	71	73	73	73	78	78	79	79	80	dB(A)
Sound pressure level at 5 meters	61	61	62	62	65	65	65	69	69	70	70	71	dB(A)
Sound pressure level at 10 meters	56	56	57	57	59	59	59	64	64	65	65	66	dB(A)
Low noise setting up (AS)	40.2	50.2	60.2	70.2	80.2	90.2	100.2	115.2	130.2	145.2	160.2	180.2	
Sound power level <sup>(E)</sup>	85	85	86	86	88	88	88	93	93	94	94	95	dB(A)
Sound pressure level at 1 meter	67	67	68	68	70	70	70	75	75	76	76	77	dB(A)
Sound pressure level at 5 meters	58	58	59	59	62	62	62	66	66	67	67	68	dB(A)
Sound pressure level at 10 meters	53	53	54	54	56	56	56	61	61	62	62	63	dB(A)

(E): EUROVENT certified data

The acoustic performances are referred to units operating in cooling mode at nominal conditions A35W7.

Unit placed in free field on reflecting surface (directional factor equal to 2).

The sound power level is measured according to ISO 9614 standard.

The sound pressure level is calculated according to ISO 3744 and is referred to a distance of 1/5/10 metres from the external surface of the unit.

**Technical data**

Unit	40.2	50.2	60.2	70.2	80.2	90.2	100.2	115.2	130.2	145.2	160.2	180.2	
Power supply	400 - 3 - 50												V-ph-Hz
Compressor type	scroll												-
N° compressors / N° refrigerant circuits	2 / 1												n°
Plant side heat exchanger type	stainless steel brazed plates												-
Source side heat exchanger type	finned coil												-
Fans type	centrifugal												-
N° fans	1			2			3			4			n°
Tank volume	200				400				460				l
Hydraulic fittings	2" VICTAULIC						2" 1/2 VICTAULIC						-

**Electrical data**

Standard unit	40.2	50.2	60.2	70.2	80.2	90.2	100.2	115.2	130.2	145.2	160.2	180.2	
<b>FLA</b> - Full load current at maximum tolerated conditions	43,2	48,8	56,7	62,1	74,9	80,5	95,0	109	117	145	169	188	A
<b>FLI</b> - Full load power input at maximum tolerated conditions	25,2	28,0	33,0	35,6	41,9	47,3	58,3	67,3	72,8	88,7	103	113	kW
<b>MIC</b> - Maximum instantaneous current of the unit	137	147	152	177	218	269	264	278	278	370	394	384	A
<b>MIC SS</b> - Maximum instantaneous current of the unit with soft starter options	92,4	99,4	105	121	148	179	180	194	194	222	279	277	A
Unit with high head modulating pump	40.2	50.2	60.2	70.2	80.2	90.2	100.2	115.2	130.2	145.2	160.2	180.2	
<b>FLA</b> - Full load current at maximum tolerated conditions	49,3	54,9	62,8	68,2	81,0	86,6	101	118	126	153	179	198	A
<b>FLI</b> - Full load power input at maximum tolerated conditions	28,7	31,5	36,5	39,1	45,4	50,8	61,8	71,8	77,3	93,2	109	119	kW
<b>MIC</b> - Maximum instantaneous current of the unit	143	153	158	183	224	275	270	287	287	378	405	394	A
<b>MIC SS</b> - Maximum instantaneous current of the unit with soft starter options	98,5	105	111	127	155	185	186	203	203	231	290	287	A

**Operative range**

Temperature	Unit type	Cooling		Heating		
		min	max	min	max	
Outdoor air inlet temperature	IR, BR, IP, BP	-10*	50	-15	40*	(°C)
Water outlet temperature	IR, IP	5	25	30	55	(°C)
Water outlet temperature	BR, BP	-12	25	30	55	(°C)
Water outlet temperature (VD)	IR, BR, IP, BP	30	70	30	70	(°C)
Water outlet temperature (VR)	IR, BR	30	55	-	-	(°C)

\* with fans modulating control option (condensation / evaporation control)

**Aeraulic performance**

Unit	40.2	50.2	60.2	70.2	80.2	90.2	100.2	115.2	130.2	145.2	160.2	180.2	200.2	
Available static head	150	150	150	150	150	150	150	150	150	150	150	150	150	Pa

## VD and VR versions

These units allow to recover the heating power, otherwise wasted on air, through an additional heat exchanger.

The **Desuperheater Version (VD)** allow the hot water production at temperatures between 30 and 70°C through the partial heat recovery of the condensation heat.

The **Total Recovery Version (VR)** allows the cold water production and, at the same time, the hot water production at temperatures between 30 and 55°C through the total recovery of the condensation heat.

### Desupeheater Version (VD) - NET NOMINAL performances

IR	Base setting up (AB)	40.2	50.2	60.2	70.2	80.2	90.2	100.2	115.2	130.2	145.2	160.2	180.2	
A35W7 - W45	Cooling capacity	49,1	58,1	65,5	73,3	86,7	98,6	110	125	138	159	180	205	kW
	Total power input	14,5	16,7	19,4	21,5	26,6	30,5	33,8	37,7	41,6	48,8	54,1	63,1	kW
	<b>EER</b>	<b>3,38</b>	<b>3,47</b>	<b>3,38</b>	<b>3,41</b>	<b>3,26</b>	<b>3,24</b>	<b>3,27</b>	<b>3,32</b>	<b>3,32</b>	<b>3,26</b>	<b>3,32</b>	<b>3,24</b>	W/W
	<b>HRE</b>	<b>4,36</b>	<b>4,48</b>	<b>4,36</b>	<b>4,4</b>	<b>4,21</b>	<b>4,18</b>	<b>4,22</b>	<b>4,28</b>	<b>4,29</b>	<b>4,21</b>	<b>4,29</b>	<b>4,19</b>	W/W
	Water flow rate	2,36	2,79	3,15	3,53	4,17	4,74	5,3	6,02	6,64	7,64	8,65	9,84	l/s
	Water pressure drop	26	37	36	44	34	35	37	36	38	38	41	42	kPa
	Heating recovery capacity	14,2	16,9	19	21,3	25,1	28,6	32,1	36,2	40,3	46,3	52,3	59,4	kW
	Water flow rate recovery	0,68	0,81	0,91	1,02	1,2	1,37	1,53	1,73	1,93	2,21	2,5	2,84	l/s
	Water pressure drop recovery	7	10	13	16	21	16	20	12	15	20	25	20	kPa
	IP	Base setting up (AB)	40.2	50.2	60.2	70.2	80.2	90.2	100.2	115.2	130.2	145.2	160.2	180.2
A35W7 - W45	Cooling capacity	47,1	55,8	63,1	70,4	84,6	96	107	120	133	153	173	199	kW
	Total power input	14,2	16,6	18,9	21,2	26	29,5	33	36,8	40,7	47,3	53,1	61,4	kW
	<b>EER</b>	<b>3,32</b>	<b>3,36</b>	<b>3,33</b>	<b>3,33</b>	<b>3,25</b>	<b>3,25</b>	<b>3,25</b>	<b>3,27</b>	<b>3,27</b>	<b>3,24</b>	<b>3,26</b>	<b>3,24</b>	W/W
	<b>HRE</b>	<b>4,28</b>	<b>4,34</b>	<b>4,3</b>	<b>4,3</b>	<b>4,19</b>	<b>4,2</b>	<b>4,2</b>	<b>4,21</b>	<b>4,22</b>	<b>4,18</b>	<b>4,2</b>	<b>4,17</b>	W/W
	Water flow rate	2,26	2,68	3,03	3,39	4,06	4,61	5,16	5,78	6,4	7,36	8,31	9,56	l/s
	Water pressure drop	24	34	33	41	32	33	35	33	35	35	38	40	kPa
	Heating recovery capacity	13,6	16,2	18,3	20,5	24,5	27,9	31,1	34,7	38,6	44,4	50,1	57,5	kW
	Water flow rate recovery	0,65	0,77	0,87	0,98	1,17	1,33	1,49	1,66	1,84	2,12	2,39	2,75	l/s
	Water pressure drop recovery	7	9	12	14	20	16	19	11	14	18	23	19	kPa

### Total Recovery Version (VR) - NET NOMINAL performances

IR	Base setting up (AB)	40.2	50.2	60.2	70.2	80.2	90.2	100.2	115.2	130.2	145.2	160.2	180.2	
A35W7 - W45	Cooling capacity	49,1	58,1	65,5	73,3	86,7	98,6	110	125	138	159	180	205	kW
	Total power input	13,2	15,4	17,4	19,5	22,8	26,6	29,9	33,7	37,7	43	48,2	55,4	kW
	<b>EER</b>	<b>3,72</b>	<b>3,76</b>	<b>3,77</b>	<b>3,75</b>	<b>3,81</b>	<b>3,72</b>	<b>3,7</b>	<b>3,71</b>	<b>3,66</b>	<b>3,7</b>	<b>3,73</b>	<b>3,7</b>	W/W
	<b>HRE</b>	<b>8,39</b>	<b>8,47</b>	<b>8,49</b>	<b>8,46</b>	<b>8,55</b>	<b>8,39</b>	<b>8,35</b>	<b>8,37</b>	<b>8,27</b>	<b>8,36</b>	<b>8,42</b>	<b>8,34</b>	W/W
	Water flow rate	2,36	2,79	3,15	3,53	4,17	4,74	5,3	6,02	6,64	7,64	8,65	9,84	l/s
	Water pressure drop	26	37	36	44	34	35	37	36	38	38	41	42	kPa
	Heating recovery capacity	61,7	72,7	82,1	91,9	108	124	139	157	174	200	226	257	kW
	Water flow rate recovery	2,95	3,47	3,92	4,39	5,16	5,92	6,64	7,5	8,31	9,56	10,8	12,3	l/s
	Water pressure drop recovery	34	47	42	41	48	47	52	49	51	50	54	53	kPa

Data declared according to EN 14511. The values are referred to units without options and accessories.

**EER** (Energy Efficiency Ratio) = ratio of the total cooling capacity to the effective power input of the unit

**HRE** (Heat Recovery Efficiency) = ratio of the total capacity of the system (heating plus cooling capacity) to the effective power input

**A35W7 - W45** = source : air in 35°C d.b. / plant : water in 12°C out 7°C / Recovery : water in 40°C out 45°C

## CONTROL SYSTEM

The units are equipped with a controller designed to ensure energy saving and unit efficiency. Available functions :

- Adaptive function
- Dynamic defrost
- Sound management
- Climatic control in heating and in cooling mode
- Economy function
- Demand limit
- Integrative heating
- Remote stand by
- Remote cooling-heatingg



## DIMENSIONS - MINIMUM OPERATING AREA - WEIGHT

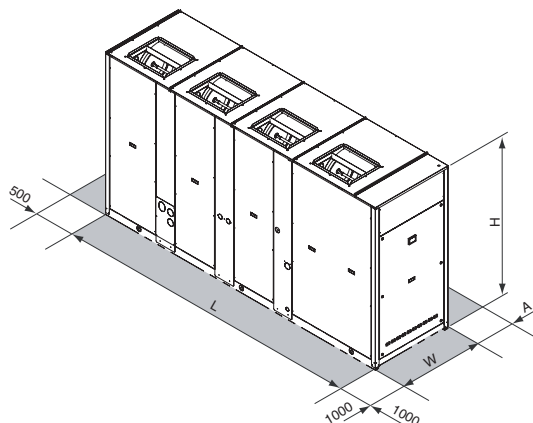

	40.2	50.2	60.2	70.2	80.2	90.2	100.2	115.2	130.2	145.2	160.2	180.2	
L		2501				3343			3343		4097		mm
W		954				1104			1104		1104		mm
H		1760				1760			2160		2160		mm
A		1600							2000				mm
Operating maximum weight*	1121	1125	1146	1189	1670	1751	1836	2051	2080	2124	2478	2520	kg

\* Weight refers to the unit IP with tank and pumping module 2 pumps.



# > RGW

## AIR-WATER CHILLERS AND HEAT PUMPS FOR INDOOR INSTALLATION



Unit with closing panels

### Available range

#### Unit type

IR	Chiller
IW	Heat pump (reversible on the water side)
IP	Heat pump (reversible on the refrigerant side)
BR	Chiller Brine
BW	Heat pump Brine (reversible on the water side)
BP	Heat pump Brine (reversible on the refrigerant side)

#### Version

VB	Base version
----	--------------

#### Acoustic setting up

AB	Base setting up
AS	Low noise setting up
AX	eXtra low noise setting up

### Unit description

This series of water-water chillers and heat pumps satisfies the cooling and heating requirements of commercial and industrial plants of medium size.

All the units are suitable for indoor installation and can be applied to fan coil plants, radiant floor plants and high efficiency radiators plants.

The refrigerant circuit is equipped with 2 scroll compressors, mounted on rubber vibration-damper supports, plant side heat exchanger brazed plate-type in stainless steel (AISI 316), complete with thermal insulation shell and differential pressure switch, source side exchanger brazed plate-type in stainless steel (AISI 316), complete with thermal insulation (IW, IP, BW, BP only) and differential pressure switch. (IP, BP only), thermostatic

expansion valve or electronic expansion valve (standard for IP, BP), 4-way valve, dehydrator filter, refrigerant circuit protected by refrigerant safety valve, low and high pressure switches, electrical panel for power and control complete with main breaker power supply with door lock function microprocessor controller with keyboard-display, and phase sequence controller (standard). When developing the range special attention has been paid to the choice of heat exchangers in order to obtain high efficiencies at full and partial loads to maximise the seasonal efficiency rating (ESEER) and therefore reduce consumption and running costs. The units can be chosen in Basic setting up (AB) (unit without closing panels), Low noise setting up (AS), featuring closing panels coated with acoustic material, Extra Low noise setting up (AX) featuring closing panels coated with superior acoustic material and soundproofing jackets on the compressors.

A wide range of accessories completes the commercial offer. These include pumping modules with 1 or 2 pumps available with standard or high head with a maximum of 4 pumps: 2 on plant side and 2 on source side.

The electronic controller can manage the various condensation control systems of the numerous applications required, enabling the control of 2-way or 3-way modulating valves (also offered as accessories) or the control of pumps under INVERTER. The units can therefore be combined with liquid coolers (dry-coolers), cooling towers, geothermal boreholes or use for water cooling city or well water. All the units are carefully built in compliance with the current regulations and individually tested. Installation therefore only requires the electrical and hydraulic connection.

### Options

#### Pumping Modules

Available on various configurations:

- 1 or 2 pumps plant side
- 1 or 2 pumps source side
- pumps standard, high and extra high pressure head

#### Expansion valve

- thermostatic
- electronic (standard for IP, BP)

Suitable for outdoor installation

### Accessories

Rubber vibration dampers

Remote controller

Serial Interface Modbus-RS 485

Programmer clock

Phase sequence and voltage controller

Low temperature kit

High and low pressure gauges

High temperature thermostat

Compressors shut-off valves

(for IR, BR, IW, BW only)

Outdoor air sensor

Water flow switch

Victaulic hydraulic fittings

Victaulic bends

Victaulic water shut-off valves

Victaulic water filter

2-way valve for cond./evap control

3-way valve for cond./evap control

Compressors start-up with soft starter

Compressors power factor correction

Electrical load protection with thermal magnetic circuit breakers

**NET NOMINAL performances - Standard plants - EUROVENT certified data**

IR		70.2	80.2	90.2	105.2	120.2	135.2	150.2	170.2	190.2	215.2	240.2	
W30W7	Cooling capacity	69,5	78,5	91,4	104,3	117,2	132,1	146,9	168,8	190,5	214,3	238,1	kW
	Power input	16,4	18,1	21,9	25,2	28,6	32,3	36,3	41,3	46,4	53,0	59,7	kW
	<b>EER</b>	<b>4,23</b>	<b>4,34</b>	<b>4,17</b>	<b>4,14</b>	<b>4,10</b>	<b>4,09</b>	<b>4,05</b>	<b>4,09</b>	<b>4,11</b>	<b>4,04</b>	<b>3,99</b>	W/W
	<b>ESEER</b>	<b>5,22</b>	<b>5,26</b>	<b>5,07</b>	<b>5,04</b>	<b>5,02</b>	<b>5,03</b>	<b>5,05</b>	<b>5,03</b>	<b>5,07</b>	<b>5,03</b>	<b>5,04</b>	W/W
	Water flow rate plant side	3,3	3,8	4,4	5,0	5,6	6,4	7,1	8,1	9,2	10,3	11,5	l/s
	Pressure drops plant side	47	38	40	41	44	42	45	46	48	48	49	kPa
	Water flow rate source side	4,0	4,5	5,3	6,1	6,8	7,7	8,6	9,8	11,1	12,5	13,9	l/s
	Pressure drops source side	68	55	59	60	65	62	66	67	70	71	72	kPa
IW		70.2	80.2	90.2	105.2	120.2	135.2	150.2	170.2	190.2	215.2	240.2	
W30W7	Cooling capacity	69,5	78,5	91,4	104,3	117,2	132,1	146,9	168,8	190,5	214,3	238,1	kW
	Power input	16,4	18,1	21,9	25,2	28,6	32,3	36,3	41,3	46,4	53,0	59,7	kW
	<b>EER</b>	<b>4,23</b>	<b>4,34</b>	<b>4,17</b>	<b>4,14</b>	<b>4,10</b>	<b>4,09</b>	<b>4,05</b>	<b>4,09</b>	<b>4,11</b>	<b>4,04</b>	<b>3,99</b>	-
	<b>ESEER</b>	<b>5,22</b>	<b>5,26</b>	<b>5,07</b>	<b>5,04</b>	<b>5,02</b>	<b>5,03</b>	<b>5,05</b>	<b>5,03</b>	<b>5,07</b>	<b>5,03</b>	<b>5,04</b>	-
	Water flow rate plant side	3,34	3,77	4,40	5,02	5,64	6,35	7,07	8,12	9,17	10,32	11,47	l/s
	Pressure drops plant side	47	38	40	41	44	42	45	46	48	48	49	kPa
	Water flow rate source side	4,03	4,54	5,32	6,07	6,83	7,71	8,58	9,84	11,09	12,52	13,94	l/s
	Pressure drops source side	68	55	59	60	65	62	66	67	70	71	72	kPa
W10W45	Heating capacity	78,7	87,6	103,8	117,9	132,1	149,2	166,5	190,7	215,0	242,3	270,6	kW
	Power input	20,6	22,5	27,1	30,9	34,8	39,2	44,1	50,2	56,5	63,8	71,4	kW
	<b>COP</b>	<b>3,81</b>	<b>3,90</b>	<b>3,84</b>	<b>3,82</b>	<b>3,80</b>	<b>3,81</b>	<b>3,78</b>	<b>3,80</b>	<b>3,81</b>	<b>3,80</b>	<b>3,79</b>	-
	Water flow rate plant side	3,73	4,16	4,92	5,59	6,26	7,07	7,88	9,03	10,18	11,47	12,80	l/s
	Pressure drops plant side	58	46	50	51	54	52	56	57	59	59	61	kPa
	Water flow rate source side	4,03	4,54	5,32	6,07	6,83	7,71	8,58	9,84	11,09	12,52	13,94	l/s
Pressure drops source side	68	55	59	60	65	62	66	67	70	71	72	kPa	
IP		70.2	80.2	90.2	105.2	120.2	135.2	150.2	170.2	190.2	215.2	240.2	
W30W7	Cooling capacity	68,1	77,0	89,6	102,3	114,9	129,5	144,0	165,4	186,8	210,1	233,4	kW
	Power input	16,2	17,9	21,6	24,9	28,2	31,8	35,8	40,7	45,7	52,3	58,9	kW
	<b>EER</b>	<b>4,20</b>	<b>4,31</b>	<b>4,14</b>	<b>4,11</b>	<b>4,07</b>	<b>4,07</b>	<b>4,03</b>	<b>4,07</b>	<b>4,09</b>	<b>4,02</b>	<b>3,96</b>	-
	<b>ESEER</b>	<b>5,16</b>	<b>5,20</b>	<b>5,02</b>	<b>5,01</b>	<b>5,00</b>	<b>5,01</b>	<b>5,02</b>	<b>5,00</b>	<b>5,02</b>	<b>5,00</b>	<b>5,01</b>	-
	Water flow rate plant side	3,3	3,7	4,3	4,9	5,5	6,2	6,9	8,0	9,0	10,1	11,2	l/s
	Pressure drops plant side	45	36	38	39	42	40	43	44	46	46	47	kPa
	Water flow rate source side	3,95	4,45	5,22	5,96	6,71	7,57	8,43	9,66	10,89	12,29	13,69	l/s
	Pressure drops source side	66	53	56	58	62	60	64	65	68	68	70	kPa
W10W45	Heating capacity	77,7	86,6	102,8	116,8	130,8	147,7	165,4	188,8	212,8	239,8	267,9	kW
	Power input	20,7	22,5	27,1	31,0	34,9	39,3	44,2	50,3	56,4	64,0	71,6	kW
	<b>COP</b>	<b>3,76</b>	<b>3,85</b>	<b>3,80</b>	<b>3,77</b>	<b>3,75</b>	<b>3,76</b>	<b>3,74</b>	<b>3,76</b>	<b>3,77</b>	<b>3,75</b>	<b>3,74</b>	-
	Water flow rate plant side	3,7	4,1	4,9	5,5	6,2	7,0	7,8	8,9	10,1	11,4	12,7	l/s
	Pressure drops plant side	57	45	49	50	53	51	55	56	58	58	60	kPa
	Water flow rate source side	3,95	4,45	5,22	5,96	6,71	7,57	8,43	9,66	10,89	12,29	13,69	l/s
Pressure drops source side	66	53	56	58	62	60	64	65	68	68	70	kPa	

Data declared according to **EN 14511**. The values are referred to units without options and accessories.

**EER** (Energy Efficiency Ratio) = ratio of the total cooling capacity to the effective power input of the unit

**COP** (Coefficient Of Performance) = ratio of the total heating capacity to the effective power input of the unit

**ESEER** (European Seasonal Energy Efficiency Ratio) = Unit in **A CLASS**.

**W30W7** = source : water in 30°C out 35°C / plant : water in 12°C out 7°C

**W10W45** = source : water in 10°C / plant : water in 40°C out 45°C

**NET NOMINAL performances - Radiant plants**

IR		70.2	80.2	90.2	105.2	120.2	135.2	150.2	170.2	190.2	215.2	240.2		
W30W7	Cooling capacity	94,0	105,2	121,2	140,0	158,7	178,4	197,6	227,0	257,2	288,8	321,4	kW	
	Power input	18,8	20,3	24,5	28,4	32,6	36,6	41,3	47,1	53,2	60,7	68,6	kW	
	<b>EER</b>	<b>5,01</b>	<b>5,19</b>	<b>4,95</b>	<b>4,94</b>	<b>4,86</b>	<b>4,88</b>	<b>4,79</b>	<b>4,82</b>	<b>4,83</b>	<b>4,76</b>	<b>4,69</b>	-	
	Water flow rate plant side	4,55	5,08	5,86	6,77	7,68	8,63	9,56	10,99	12,46	13,99	15,58	l/s	
	Pressure drops plant side	87	69	71	75	82	78	82	84	89	88	90	kPa	
	Water flow rate source side	5,25	5,87	6,80	7,86	8,92	10,03	11,13	12,77	14,45	16,27	18,14	l/s	
	Pressure drops source side	116	92	96	101	110	105	111	114	119	119	123	kPa	
IW		<b>70.2</b>	<b>80.2</b>	<b>90.2</b>	<b>105.2</b>	<b>120.2</b>	<b>135.2</b>	<b>150.2</b>	<b>170.2</b>	<b>190.2</b>	<b>215.2</b>	<b>240.2</b>		
	W30W7	Cooling capacity	94,0	105,2	121,2	140,0	158,7	178,4	197,6	227,0	257,2	288,8	321,4	kW
		Power input	18,8	20,3	24,5	28,4	32,6	36,6	41,3	47,1	53,2	60,7	68,6	kW
		<b>EER</b>	<b>5,01</b>	<b>5,19</b>	<b>4,95</b>	<b>4,94</b>	<b>4,86</b>	<b>4,88</b>	<b>4,79</b>	<b>4,82</b>	<b>4,83</b>	<b>4,76</b>	<b>4,69</b>	-
		Water flow rate plant side	4,55	5,08	5,86	6,77	7,68	8,63	9,56	10,99	12,46	13,99	15,58	l/s
		Pressure drops plant side	87	69	71	75	82	78	82	84	89	88	90	kPa
		Water flow rate source side	5,25	5,87	6,80	7,86	8,92	10,03	11,13	12,77	14,45	16,27	18,14	l/s
Pressure drops source side		116	92	96	101	110	105	111	114	119	119	123	kPa	
W10W45	Heating capacity	85,2	95,8	112,3	128,3	144,5	162,9	181,5	208,1	234,8	264,9	295,2	kW	
	Power input	17,9	19,4	23,5	27,2	31,0	34,9	39,3	44,9	50,6	57,8	65,3	kW	
	<b>COP</b>	<b>4,75</b>	<b>4,93</b>	<b>4,78</b>	<b>4,73</b>	<b>4,65</b>	<b>4,67</b>	<b>4,61</b>	<b>4,64</b>	<b>4,64</b>	<b>4,58</b>	<b>4,52</b>	-	
	Water flow rate plant side	4,03	4,54	5,32	6,07	6,83	7,71	8,58	9,84	11,09	12,52	13,94	l/s	
	Pressure drops plant side	68	55	59	60	65	62	66	67	70	71	72	kPa	
	Water flow rate source side	5,25	5,87	6,80	7,86	8,92	10,03	11,13	12,77	14,45	16,27	18,14	l/s	
	Pressure drops source side	116	92	96	101	110	105	111	114	119	119	123	kPa	
IP		<b>70.2</b>	<b>80.2</b>	<b>90.2</b>	<b>105.2</b>	<b>120.2</b>	<b>135.2</b>	<b>150.2</b>	<b>170.2</b>	<b>190.2</b>	<b>215.2</b>	<b>240.2</b>		
	W30W7	Cooling capacity	90,8	101,0	117,0	135,0	153,0	172,0	190,6	218,6	247,5	278,4	309,5	kW
		Power input	19,0	20,1	24,1	28,1	32,3	36,1	41,0	46,7	52,5	59,5	66,6	kW
		<b>EER</b>	<b>4,79</b>	<b>5,01</b>	<b>4,85</b>	<b>4,80</b>	<b>4,74</b>	<b>4,77</b>	<b>4,65</b>	<b>4,69</b>	<b>4,72</b>	<b>4,68</b>	<b>4,65</b>	-
		Water flow rate plant side	4,40	4,87	5,65	6,52	7,40	8,31	9,22	10,58	11,98	13,48	14,99	l/s
		Pressure drops plant side	81	63	66	69	76	72	77	78	82	82	84	kPa
		Water flow rate source side	5,12	5,67	6,60	7,62	8,64	9,72	10,81	12,37	13,98	15,75	17,52	l/s
Pressure drops source side		110	86	90	95	103	98	105	107	111	112	114	kPa	
W10W45	Heating capacity	83,7	94,0	110,3	126,1	142,1	159,5	178,2	204,6	230,3	260,3	289,5	kW	
	Power input	17,6	19,0	23,1	26,7	30,4	34,2	38,6	43,9	49,5	56,6	63,9	kW	
	<b>COP</b>	<b>4,74</b>	<b>4,95</b>	<b>4,78</b>	<b>4,73</b>	<b>4,68</b>	<b>4,67</b>	<b>4,62</b>	<b>4,66</b>	<b>4,65</b>	<b>4,60</b>	<b>4,53</b>	-	
	Water flow rate plant side	3,96	4,45	5,22	5,97	6,72	7,55	8,43	9,68	10,88	12,30	13,68	l/s	
	Pressure drops plant side	66	53	56	58	63	59	64	65	68	68	70	kPa	
	Water flow rate source side	5,12	5,67	6,60	7,62	8,64	9,72	10,81	12,37	13,98	15,75	17,52	l/s	
	Pressure drops source side	110	86	90	95	103	98	105	107	111	112	114	kPa	

Data declared according to **EN 14511**. The values are referred to units without options and accessories.  
**EER** (Energy Efficiency Ratio) = ratio of the total cooling capacity to the effective power input of the unit  
**COP** (Coefficient Of Performance) = ratio of the total heating capacity to the effective power input of the unit

**ESEER** (European Seasonal Energy Efficiency Ratio) = Unit in **A CLASS**.  
**W30W7** = source : water in 30°C out 35°C / plant : water in 12°C out 7°C  
**W10W45** = source : water in 10°C / plant : water in 40°C out 45°C

**Acoustic performances**

Base setting up (AB)	70.2	80.2	90.2	105.2	120.2	135.2	150.2	170.2	190.2	215.2	240.2	
Sound power level <sup>(E)</sup>	75	76	77	77	77	78	78	79	79	80	80	dB(A)
Sound pressure level at 1 meter	59	60	61	61	61	62	62	63	63	64	64	dB(A)
Sound pressure level at 5 meters	49	50	51	51	51	52	52	53	53	54	54	dB(A)
Sound pressure level at 10 meters	44	45	46	46	46	47	47	48	48	49	49	dB(A)
Low noise setting up (AS)	70.2	80.2	90.2	105.2	120.2	135.2	150.2	170.2	190.2	215.2	240.2	
Sound power level <sup>(E)</sup>	71	72	73	73	73	74	74	75	75	76	76	dB(A)
Sound pressure level at 1 meter	55	56	57	57	57	58	58	59	59	60	60	dB(A)
Sound pressure level at 5 meters	45	46	47	47	47	48	48	49	49	50	50	dB(A)
Sound pressure level at 10 meters	40	41	42	42	42	43	43	44	44	45	45	dB(A)
eXtra low noise setting up (AX)	70.2	80.2	90.2	105.2	120.2	135.2	150.2	170.2	190.2	215.2	240.2	
Sound power level <sup>(E)</sup>	67	68	69	69	69	70	70	71	71	72	72	dB(A)
Sound pressure level at 1 meter	51	52	53	53	53	54	54	55	55	56	56	dB(A)
Sound pressure level at 5 meters	41	42	43	43	43	44	44	45	45	46	46	dB(A)
Sound pressure level at 10 meters	36	37	38	38	38	39	39	40	40	41	41	dB(A)

**(E): EUROVENT** certified data  
 The acoustic performances are referred to units operating in cooling mode at nominal conditions W30/W7.  
 Unit placed in free field on reflecting surface (directional factor equal to 2).  
 The sound power level is measured according to ISO 9614 standard.  
 The sound pressure level is calculated according to ISO 3744 and is referred to a distance of 1/5/10 metres from the external surface of the unit.

**Technical data**

Unit	70.2	80.2	90.2	105.2	120.2	135.2	150.2	170.2	190.2	215.2	240.2	
Power supply	400 - 3 - 50											V-ph-Hz
Compressor type	scroll											-
N° compressors / N° refrigerant circuits	2 / 1											n°
Plant side heat exchanger type	stainless steel brazed plates											-
Source side heat exchanger type	stainless steel brazed plates											-
IN/OUT Plant side hydraulic fittings	2" 1/2 VICTAULIC											"
IN/OUT Source side hydraulic fittings	2" 1/2 VICTAULIC											"

**Electrical data**

Standard unit	70.2	80.2	90.2	105.2	120.2	135.2	150.2	170.2	190.2	215.2	240.2	
<b>FLA</b> - Full load current at maximum tolerated conditions	45	51	62	68	74	82	90	105	120	142	164	A
<b>FLI</b> - Full load power input at maximum tolerated conditions	26	29	34	40	45	50	55	63	72	83	93	kW
<b>MIC</b> - Maximum instantaneous current of the unit	141	166	204	256	262	309	317	355	370	454	476	A
<b>MIC SS</b> - Maximum instantaneous current of the unit with soft starter options	93	110	135	166	172	200	208	231	246	296	318	A
Unit with high head modulating pump	70.2	80.2	90.2	105.2	120.2	135.2	150.2	170.2	190.2	215.2	240.2	
<b>FLA</b> - Full load current at maximum tolerated conditions	60	66	77	83	89	103	111	129	144	169	191	A
<b>FLI</b> - Full load power input at maximum tolerated conditions	35	38	42	48	54	62	67	77	86	98	109	kW
<b>MIC</b> - Maximum instantaneous current of the unit	155	180	219	271	277	330	338	379	394	481	503	A
<b>MIC SS</b> - Maximum instantaneous current of the unit with soft starter options	108	124	149	181	187	221	229	255	270	323	345	A

**Operating range**

Temperature	Unit type	Cooling		Heating		
		min	max	min	max	
Water inlet temperature source side	IR, IW, IP, BR, BP	20 (5*)	50	10	25 (40*)	(°C)
Water outlet temperature plant side	IR, IW, IP	5	20	25	55	(°C)
Water outlet temperature plant side	BR, BP	-10	5	25	55	(°C)

\* with condensation / evaporation control devices

**CONTROL SYSTEM**

The units are equipped with a controller designed to ensure energy saving and unit efficiency. Available functions :

- Adaptive function
- Climatic control in heating and in cooling mode
- Economy function
- Demand limit
- Integrative heating
- Condensation / evaporation control
- Remote stand by
- Remote cooling-heating



**DIMENSIONS - MINIMUM OPERATING AREA - WEIGHT**

(reference drawing: unit with closing panel)

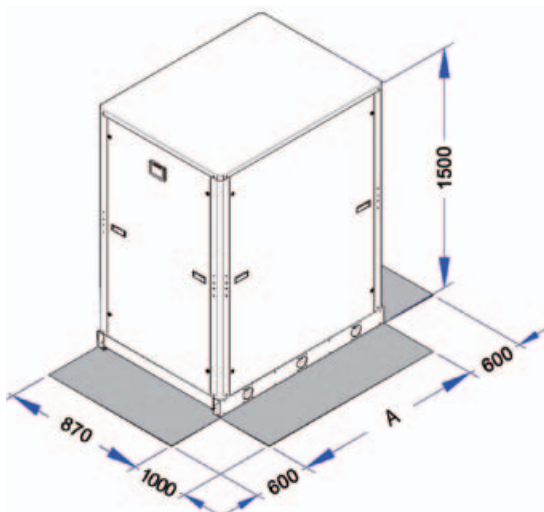

		70.2	80.2	90.2	105.2	120.2	135.2	150.2	170.2	190.2	215.2	240.2	
STANDARD UNIT	A	880				1175							mm
	Operating maximum weight	404	416	427	548	635	668	696	741	771	812	844	kg
STANDARD UNIT+ PUMPING MODULE MP	A	2055				2350							mm
	(2+2 extra high head pumps) Operating maximum weight (2+2 extra high head pumps)	809	817	828	1059	1146	1225	1253	1321	1351	1415	1447	kg



# > RVW

## WATER-WATER CHILLERS FOR INDOOR INSTALLATION



### Available range

#### Unit type

IR	Chiller
IW	Heat pump (reversible on the water side)
BR	Chiller Brine
BW	Heat pump Brine (reversible on the water side)

#### Version

VB	Base version
VD	Desuperheater version
VR	Total recovery version

#### Acoustic setting up

AB	Base setting up
AS	Low noise setting up

#### Condenser Options

T	cooling tower water
P	well water
S	sea water

### Unit description

This range of water-water chillers are designed to meet the climate control and air conditioning needs of large capacity systems in the industrial and commercial sectors. All the units are suitable for indoor installation and can be applied to fan coil plants and radiant floor plants.

Suitable for indoor installation, as standard the units are equipped with 1 or 2 TWIN-SCREW semihermetic compressors mounted on rubber vibration dampers able to modulate the capacity from minimum 25 (not for all configurations) to 100%, plant side exchanger shell and tube type complete with Victaulic water connections, fitted inside a shell of thermal insulation material to prevent condensation and heat exchange with the outside, optimised for R134a with high efficiency grooved tubes, protected by means of a water differential pressure switch, source side exchanger shell and tube type optimised for R134a with high efficiency grooved tubes complete with

Victaulic water connections, fitted inside a shell of thermal insulation material to prevent heat exchange (IW, BW only)

1 or 2 independent refrigerant circuits, complete with electronic expansion valve which optimises unit efficiency at full and partial loads and enables maximum seasonal efficiency, maximum and minimum pressure switch, PED safety valves, dehydrator filter, liquid/moisture indicator, compressor discharge and liquid shut-off valves, high and low pressure transducers, electrical panel with minimum protection IP54 containing the electrical equipment and all the components to control and command the unit complete with main supply breaker with door lock function, phase sequence control device, microprocessor controller with display (4 lines of 20 characters).

When developing the range special attention has been paid to the choice of heat exchangers in order to obtain high efficiencies at full loads and partial loads to maximise the seasonal efficiency rating (ESEER) and therefore reduce consumption and running costs

The units can be selected as Base setting up (AB) or as Low noise setting up (AS) that provides that compressor are positioned inside a soundproofed cabin, made with profiles and panels insulated with acoustic material.

The range is completed with numerous accessories and options.

The electronic controller can manage the various condensation control systems of the numerous applications required, enabling the control of 2-way or 3-way modulating valves or the control of pumps under INVERTER. The units can therefore be combined with liquid coolers (dry-coolers), cooling towers, geothermal boreholes or use for water cooling city or well water (condenser option P) or sea water (condenser option S). All the units are carefully built in compliance with the current regulations and individually tested. Installation therefore only requires the electrical and hydraulic connection.

### Options

#### Compressor starting

- standard (contactors)
- soft starter

#### Compressors power factor correction

#### Electrical load protection

- standard (fuses)
- thermal magnetic circuit breakers

#### Evaporator flow switch (mounted)

#### Evaporator insulation higher thickness

#### Evaporator electrical heater for winter antifreeze

#### High and low pressure gauges

#### Compressor suction shut-off valve

### Accessories

#### Rubber vibration dampers

External Water Storage Tank and Pumping Module complete with insulated carbon steel tank, single or twin pump and all hydronic components.

#### Antifreeze electrical heaters for Storage tank

#### Remote controller

#### Serial Interface Modbus on RS 485

#### Programmer clock

#### Phase sequence and voltage controller

#### Water flow switch

**NET NOMINAL performances - Standard plants - EUROVENT certified data**

IR		280.1	320.1	360.1	420.1	480.1	540.1	600.1	710.2	820.2	950.2	1100.2	1200.2	
<b>W30W7</b>	Cooling capacity	280	315	353	409	474	532	587	698	812	927	1056	1159	kW
	Power input	62,6	70,4	79,4	91,1	108	120	133	159	182	215	244	263	kW
	<b>EER</b>	<b>4,47</b>	<b>4,48</b>	<b>4,45</b>	<b>4,49</b>	<b>4,40</b>	<b>4,42</b>	<b>4,41</b>	<b>4,38</b>	<b>4,45</b>	<b>4,30</b>	<b>4,33</b>	<b>4,41</b>	<b>W/W</b>
	<b>ESEER</b>	<b>4,83</b>	<b>4,77</b>	<b>4,78</b>	<b>4,83</b>	<b>4,84</b>	<b>4,79</b>	<b>4,84</b>	<b>4,82</b>	<b>4,90</b>	<b>4,83</b>	<b>4,86</b>	<b>4,87</b>	<b>W/W</b>
	Water flow rate plant side	13,5	15,1	17,0	19,7	22,8	25,6	28,3	33,6	39,1	44,7	50,9	55,8	l/s
	Pressure drops plant side	46	37	46	44	55	43	54	52	45	57	59	45	kPa
	Water flow rate source side	16,3	18,3	20,6	23,8	27,6	31,1	34,3	40,8	47,3	54,2	61,8	67,7	l/s
	Pressure drops source side	29	25	26	28	38	27	25	26	28	38	27	25	kPa
<b>IW</b>		280.1	320.1	360.1	420.1	480.1	540.1	600.1	710.2	820.2	950.2	1100.2	1200.2	
<b>W30W7</b>	Cooling capacity	280	315	353	409	474	532	587	698	812	927	1056	1159	kW
	Power input	62,6	70,4	79,4	91,1	108	120	133	159	182	215	244	263	kW
	<b>EER</b>	<b>4,47</b>	<b>4,48</b>	<b>4,45</b>	<b>4,49</b>	<b>4,40</b>	<b>4,42</b>	<b>4,41</b>	<b>4,38</b>	<b>4,45</b>	<b>4,30</b>	<b>4,33</b>	<b>4,41</b>	<b>W/W</b>
	<b>ESEER</b>	<b>4,83</b>	<b>4,77</b>	<b>4,78</b>	<b>4,83</b>	<b>4,84</b>	<b>4,79</b>	<b>4,84</b>	<b>4,82</b>	<b>4,90</b>	<b>4,83</b>	<b>4,86</b>	<b>4,87</b>	<b>W/W</b>
	Water flow rate plant side	13,5	15,1	17,0	19,7	22,8	25,6	28,3	33,6	39,1	44,7	50,9	55,8	l/s
	Pressure drops plant side	46	37	46	44	55	43	54	52	45	57	59	45	kPa
	Water flow rate source side	16,3	18,3	20,6	23,8	27,6	31,1	34,3	40,8	47,3	54,2	61,8	67,7	l/s
	Pressure drops source side	29	25	26	28	38	27	25	26	28	38	27	25	kPa
<b>W10W45</b>	Heating capacity	311	350	395	455	534	592	659	783	908	1055	1184	1304	kW
	Power input	72,8	82,7	93,4	104	128	139	155	186	213	256	279	311	kW
	<b>COP</b>	<b>4,28</b>	<b>4,23</b>	<b>4,24</b>	<b>4,36</b>	<b>4,16</b>	<b>4,26</b>	<b>4,25</b>	<b>4,20</b>	<b>4,27</b>	<b>4,12</b>	<b>4,25</b>	<b>4,19</b>	<b>W/W</b>
	Water flow rate plant side	14,8	16,7	18,8	21,7	25,4	28,2	31,4	37,3	43,2	50,2	56,4	62,1	l/s
	Pressure drops plant side	24	21	22	23	32	22	21	22	23	33	22	21	kPa
	Water flow rate source side	16,3	18,3	20,6	23,8	27,6	31,1	34,3	40,8	47,3	54,2	61,8	67,7	l/s
Pressure drops source side	29	25	26	28	38	27	25	26	28	38	27	25	kPa	

Data declared according to **EN 14511**. The values are referred to units without options and accessories.  
**EER** (Energy Efficiency Ratio) = ratio of the total cooling capacity to the effective power input of the unit  
**COP** (Coefficient Of Performance) = ratio of the total heating capacity to the effective power input of the unit

**ESEER** (European Seasonal Energy Efficiency Ratio)  
 = Unit in **A CLASS**.  
**W30W7** = source : water in 30°C out 35°C / plant : water in 12°C out 7°C  
**W10W45** = source : water in 10°C / plant : water in 40°C out 45°C

**Acoustic performances**

<b>Base setting up (AB)</b>	280.1	320.1	360.1	420.1	480.1	540.1	600.1	710.2	820.2	950.2	1100.2	1200.2	
Sound power level <sup>(E)</sup>	97	97	97	98	98	98	98	99	100	100	100	100	dB(A)
Sound pressure level at 1 meter	79	79	79	80	80	80	80	80	81	81	81	81	dB(A)
Sound pressure level at 5 meters	70	70	70	72	72	72	71	72	73	73	73	73	dB(A)
Sound pressure level at 10 meters	65	65	65	67	67	67	66	67	68	68	68	68	dB(A)
<b>Low noise setting up (AS)</b>	280.1	320.1	360.1	420.1	480.1	540.1	600.1	710.2	820.2	950.2	1100.2	1200.2	
Sound power level <sup>(E)</sup>	92	93	92	93	93	94	94	94	95	95	96	96	dB(A)
Sound pressure level at 1 meter	74	75	74	75	75	76	76	75	76	76	77	77	dB(A)
Sound pressure level at 5 meters	65	66	65	66	66	67	67	67	68	68	69	69	dB(A)
Sound pressure level at 10 meters	60	61	60	61	61	62	62	62	63	63	64	64	dB(A)

**(E): EUROVENT certified data**  
 The acoustic performances are referred to units operating in cooling mode at nominal conditions W30/W7.  
 Unit placed in free field on reflecting surface (directional factor equal to 2).  
 The sound power level is measured according to ISO 9614 standard.  
 The sound pressure level is calculated according to ISO 3744 and is referred to a distance of 1/5/10 metres from the external surface of the unit.

**Technical data**

TECHNICAL DATA	280.1	320.1	360.1	420.1	480.1	540.1	600.1	710.2	820.2	950.2	1100.2	1200.2	
Power supply	400 - 3 - 50												V-ph-Hz
Compressor type	twin-screw												-
N° compressors / N° refrigerant circuits	1 / 1						2 / 2						n°
Part load	25 / 100% continuous						12.5 / 100% continuous						-
Plant side heat exchanger type / N°	shell and tube / 1						shell and tube / 2						-
Source side heat exchanger type / N°	shell and tube / 1						shell and tube / 2						-
IN/OUT Plant hydraulic fittings (victaulic)	DN125	DN125	DN125	DN150	DN150	DN150	DN200	DN150	DN200	DN200	DN200	DN200	-
IN/OUT Source hydraulic fittings (victaulic)	DN100	DN100	DN100	DN100	DN100	DN125	DN125	DN100	DN100	DN100	DN125	DN125	-

**Electrical data**

Standard unit	280.1	320.1	360.1	420.1	480.1	540.1	600.1	710.2	820.2	950.2	1100.2	1200.2	
<b>FLA</b> - Full load current at maximum tolerated conditions	162	181	211	232	270	309	340	422	464	540	618	680	A
<b>FLI</b> - Full load power input at maximum tolerated conditions	99	110	129	144	169	190	209	257	287	339	380	418	kW
<b>MIC</b> - Maximum instantaneous current of the unit	520	612	665	436	465	586	650	876	668	735	895	990	A

**Operative range**

Temperature	Tipo Unità	Cooling		Heating		
		min	max	min	max	
Water inlet temperature source side	IR, IW, BR	20 (5*)	50	10	25 (40*)	(°C)
Water outlet temperature plant side	IR, IW	5	15	25	55	(°C)
Water outlet temperature plant side	BR	-8	5	25	55	(°C)
Water outlet temperature Desuperheater (VD)	IR, BR	35	50	-	-	(°C)
Water outlet temperature total Recovery (VR)	IR, BR	25	55	-	-	(°C)

\* with fans modulating control option (condensation / evaporation control)

**CONTROL SYSTEM**

The units are equipped with a controller designed to ensure energy saving and unit efficiency. Available functions :

- Double Set Point
- Demand Limit
- Dinamic set point
- Integrative heating
- Condensation / evaporation control
- Remote stand by
- Remote cooling-heating



### VD and VR versions

These units allow to recover the heating power through an additional heat exchanger.

#### DESUPERHEATERS VERSION VD

Allows the production of cold water as in the base version and, simultaneously, of hot water at temperatures from 35 to 50 °C. This is achieved by inserting, between the compressor and condenser, a heat exchanger water-gas cooler which allows for heat recovery from 15 to 20% of thermal power.

#### TOTAL RECOVERY VERSION VR

Allows the production of cold water and simultaneously of hot water at temperatures from 25 to 55 °C. This is achieved using a suitable heat exchanger that has a double water circuit: one for condensation and a second for heat recovery. The management to the two hydraulic circuits is in charge of the user.

#### Desupeheater Version (VD) - NET NOMINAL performances

IR	Base setting up (AB)	280.1	320.1	360.1	420.1	480.1	540.1	600.1	710.2	820.2	950.2	1100.2	1200.2	
W30W7 - W45	Cooling capacity	291	328	367	425	493	553	610	725	844	963	1097	1204	kW
	Total power input	61	69	77	89	105	118	130	156	178	210	238	257	kW
	<b>EER</b>	<b>4,76</b>	<b>4,77</b>	<b>4,74</b>	<b>4,78</b>	<b>4,68</b>	<b>4,71</b>	<b>4,70</b>	<b>4,66</b>	<b>4,74</b>	<b>4,58</b>	<b>4,61</b>	<b>4,69</b>	<b>W/W</b>
	<b>HRE</b>	<b>5,65</b>	<b>5,67</b>	<b>5,63</b>	<b>5,68</b>	<b>5,56</b>	<b>5,60</b>	<b>5,59</b>	<b>5,55</b>	<b>5,64</b>	<b>5,45</b>	<b>5,49</b>	<b>5,59</b>	<b>W/W</b>
	Water flow rate plant side	14,0	15,8	17,7	20,5	23,8	26,6	29,4	35,0	40,6	46,5	53,0	58,0	l/s
	Water pressure drop plant side	50	40	50	48	59	47	58	56	49	62	64	49	kPa
	Water flow rate source side	16,3	18,3	20,6	23,8	27,6	31,1	34,3	40,8	47,3	54,2	61,8	67,7	l/s
	Water pressure drop source side	29	25	26	28	38	27	25	26	28	38	27	25	kPa
	Heating recovery capacity	54,4	61,7	69,1	79,2	92,2	105	115	138	158	184	210	229	kW
	Water flow rate recovery	2,60	2,95	3,30	3,79	4,40	5,02	5,50	6,60	7,57	8,81	10,0	11,0	l/s
Water pressure drop recovery	6	8	7	10	9	7	9	7	10	9	7	9	kPa	

#### Total Recovery Version (VR) - NET NOMINAL performances

IR	Base setting up (AB)	280.1	320.1	360.1	420.1	480.1	540.1	600.1	710.2	820.2	950.2	1100.2	1200.2	
W30W7 - W45	Cooling capacity	250	281	317	364	426	475	527	625	724	833	943	1039	kW
	Total power input	72	82	92	104	126	138	155	186	210	251	278	308	kW
	<b>EER</b>	<b>3,47</b>	<b>3,45</b>	<b>3,44</b>	<b>3,49</b>	<b>3,39</b>	<b>3,44</b>	<b>3,40</b>	<b>3,37</b>	<b>3,44</b>	<b>3,32</b>	<b>3,39</b>	<b>3,38</b>	<b>W/W</b>
	<b>HRE</b>	<b>7,90</b>	<b>7,86</b>	<b>7,83</b>	<b>7,93</b>	<b>7,74</b>	<b>7,83</b>	<b>7,74</b>	<b>7,68</b>	<b>7,84</b>	<b>7,58</b>	<b>7,73</b>	<b>7,71</b>	<b>W/W</b>
	Water flow rate plant side	12,0	13,5	15,2	17,5	20,5	22,8	25,3	30,0	34,8	40,1	45,4	49,9	l/s
	Water pressure drop plant side	36	29	37	35	44	34	43	42	36	46	47	36	kPa
	Heating recovery capacity	318	359	404	464	546	607	674	801	925	1072	1208	1332	kW
	Water flow rate recovery	15,2	17,2	19,3	22,2	26,1	29,0	32,2	38,3	44,2	51,2	57,7	63,6	l/s
	Water pressure drop recovery	25	22	23	24	34	24	22	23	24	34	24	22	kPa

Data declared according to **EN 14511**. The values are referred to units without options and accessories.  
**EER** (Energy Efficiency Ratio) = ratio of the total cooling capacity to the effective power input of the unit  
**HRE** (Heat Recovery Efficiency) = ratio of the total capacity of the system (heating plus cooling capacity) to the effective power input  
**W30W7 - W45** = source : water in 30°C d.b. out 35°C / plant : water in 12°C out 7°C / Recovery : water in 40°C out 45°C

### DIMENSIONS - MINIMUM OPERATING AREA - WEIGHT

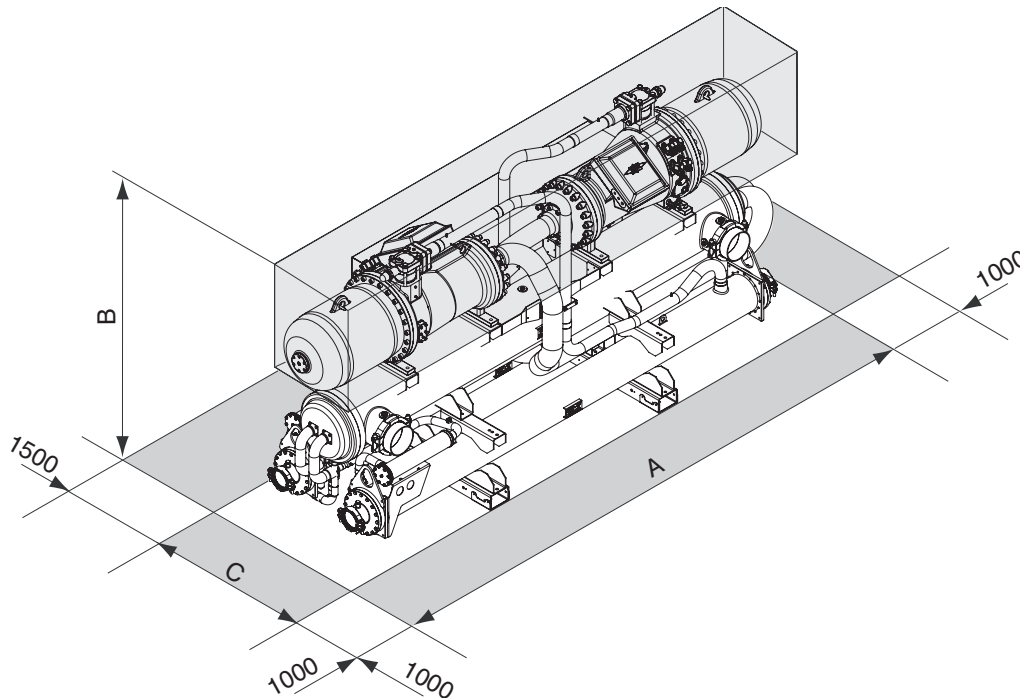

Modello	280.1	320.1	360.1	420.1	480.1	540.1	600.1	710.2	820.2	950.2	1100.2	1200.2	
A	4084	4084	4084	4084	4084	4114	4114	4320	4463	4463	4463	4463	mm
B	1878	1878	1878	1904	1904	2002	2089	1932	1993	1993	2090	2090	mm
C	1043	1043	1043	1118	1118	1118	1118	1218	1218	1218	1256	1256	mm
Operating maximum weight	1929	1947	1984	2585	2618	2785	3134	3747	5042	5059	5512	5682	kg



# > CMA - CMA HE

CONDENSING UNITS  
FOR OUTDOOR INSTALLATION



## Available range

### Unit type

- SR Condensing unit
- SP Reversible condensing unit (reversible on the refrigerant side)

### Versions

- VB Base Version

### Acoustic setting up

- AB Base setting up
- AS Low noise setting up

## Unit description

This series of condensing units satisfies the cooling and heating requirements of residential plants of small and medium size.

All the units are suitable for outdoor installation and can be connected to a remote heat exchanger properly designed in order to transfer to the plant all the cooling (and heating for reversible units) power generated.

It is possible for example to connect direct expansion coils placed inside air handling units or remote plate heat exchangers placed inside technical rooms. In both cases the lack of outdoor hydraulic pipes eliminates the freezing problems and avoids brine solutions to be used.

The refrigerant circuit, contained in a compartment protected from the air flow to simplify the maintenance operations, is

equipped with scroll compressor mounted on damper supports, axial fans with safety protection grilles, finned coil made of copper pipes and aluminium louvered fins and shut off valves on the liquid line and on the gas line. The reversible units are moreover supplied with reverse cycle valve, thermostatic expansion valve (working in heating mode) and liquid receiver.

The circuit is protected by high and low pressure switches.

All the units can be equipped with variable speed fans control that allows the units to operate with low outdoor temperatures in cooling and high outdoor temperature in heating and permits to reduce noise emissions in such operating conditions.

The low noise acoustic setting up (AS) is obtained, starting from the base setting up (AB), reducing the rotational speed of the fans and mounting sound jackets on the compressors.

All the units are supplied with an outdoor temperature sensor, already installed on the unit, in order to realize the climatic control.

All the units are provided with a phase presence and correct sequence controller device.

All the units are accurately built and individually tested in the factory.

All the units are supplied with refrigerant charge inside.

Only electric and refrigerant connections (between condensing unit and remote heat exchanger) are required for installation.

## Options

### Compressor starting

- standard (contactors)
- soft starter

### Fans control

- on-off control
- modulating control (condensation / evaporation control)

### Electrical loads protection

- fuses
- thermal magnetic circuit breakers

### Compressor power factor correction

## Accessories

Rubber vibration dampers

Coil protection grille

Remote control

Modbus serial interface on RS485

Programmer clock

Phase sequence and voltage controller

Remote plate heat exchanger

Liquid line

**NET NOMINAL performances - CMA**

SR	Base setting up (AB)	19.1	22.1	26.1	30.1	35.1	40.1	
A35E5	Cooling capacity	21,6	24,0	28,0	33,5	38,7	43,6	kW
	Power input	6,79	7,45	8,72	10,7	12,2	13,8	kW
	EER	3,18	3,21	3,20	3,13	3,17	3,16	W/W
SR	Low noise setting up (AS)	19.1	22.1	26.1	30.1	35.1	40.1	
A35E5	Cooling capacity	20,7	23,0	26,9	32,2	37,2	41,9	kW
	Power input	7,33	8,05	9,40	11,5	13,2	14,9	kW
	EER	2,83	2,86	2,86	2,80	2,82	2,81	W/W
SP	Base setting up (AB)	19.1	22.1	26.1	30.1	35.1	40.1	
A35E5	Cooling capacity	21,2	23,5	27,4	32,8	37,9	42,8	kW
	Power input	6,72	7,38	8,63	10,6	12,1	13,7	kW
	EER	3,15	3,19	3,18	3,11	3,14	3,12	W/W
A7C50	Heating capacity	20,1	22,3	25,9	31,0	35,9	40,4	kW
	Power input	6,72	7,37	8,62	10,6	12,1	13,8	kW
	COP	2,99	3,03	3,00	2,92	2,97	2,93	W/W
A7C45	Heating capacity	22,2	24,6	28,6	34,2	39,6	44,6	kW
	Power input	5,92	6,49	7,59	9,34	10,6	12,1	kW
	COP	3,75	3,79	3,77	3,66	3,74	3,69	W/W
SP	Low noise setting up (AS)	19.1	22.1	26.1	30.1	35.1	40.1	
A35E5	Cooling capacity	20,3	22,6	26,4	31,5	36,4	41,0	kW
	Power input	7,26	7,97	9,31	11,4	13,1	14,8	kW
	EER	2,80	2,83	2,83	2,76	2,78	2,78	W/W
A7C50	Heating capacity	19,0	21,2	24,7	29,6	34,2	38,5	kW
	Power input	6,45	7,08	8,27	10,2	11,7	13,2	kW
	COP	2,94	3,00	2,98	2,90	2,93	2,91	W/W
A7C45	Heating capacity	21,0	23,4	27,2	32,6	37,7	42,5	kW
	Power input	5,68	6,23	7,29	8,98	10,3	11,7	kW
	COP	3,69	3,76	3,74	3,63	3,68	3,64	W/W

**NET NOMINAL performances - CMA HE**

SR	Base setting up (AB)	19.1	22.1	26.1	30.1	35.1	40.1	
A35E5	Cooling capacity	21,8	24,2	28,3	34,2	39,7	44,9	kW
	Power input	6,48	7,10	8,25	10,2	11,8	13,3	kW
	EER	3,36	3,41	3,43	3,36	3,38	3,38	W/W
SR	Low noise setting up (AS)	19.1	22.1	26.1	30.1	35.1	40.1	
A35E5	Cooling capacity	21,0	23,2	27,2	32,9	38,2	43,2	kW
	Power input	7,01	7,67	8,91	11,00	12,70	14,30	kW
	EER	2,99	3,03	3,05	3,00	3,01	3,02	W/W
SP	Base setting up (AB)	19.1	22.1	26.1	30.1	35.1	40.1	
A35E5	Cooling capacity	21,4	23,8	27,8	33,6	39,0	44,1	kW
	Power input	6,42	7,03	8,16	10,1	11,7	13,2	kW
	EER	3,33	3,39	3,40	3,34	3,33	3,33	W/W
A7C50	Heating capacity	20,3	22,5	26,2	31,8	36,9	41,8	kW
	Power input	6,43	7,02	8,16	10,1	11,7	13,2	kW
	COP	3,16	3,21	3,21	3,15	3,15	3,17	W/W
A7C45	Heating capacity	22,4	24,8	28,9	35,1	40,7	46,1	kW
	Power input	5,66	6,19	7,19	8,86	10,3	11,7	kW
	COP	3,96	4,01	4,02	3,96	3,95	3,94	W/W
SP	Low noise setting up (AS)	19.1	22.1	26.1	30.1	35.1	40.1	
A35E5	Cooling capacity	20,5	22,8	26,7	32,3	37,5	42,3	kW
	Power input	6,94	7,59	8,82	10,9	12,6	14,2	kW
	EER	2,96	3,00	3,02	2,97	2,98	2,98	W/W
A7C50	Heating capacity	19,2	21,3	25,0	30,2	35,0	39,7	kW
	Power input	6,16	6,75	7,83	9,66	11,2	12,7	kW
	COP	3,12	3,15	3,19	3,13	3,12	3,13	W/W
A7C45	Heating capacity	21,2	23,5	27,6	33,4	38,7	43,9	kW
	Power input	5,43	5,95	6,90	8,51	9,90	11,2	kW
	COP	3,91	3,95	4,00	3,92	3,91	3,92	W/W

The values are referred to units without options and accessories.

**EER** (Energy Efficiency Ratio) = ratio of the total cooling capacity to the effective power input of the unit

**COP** (Coefficient Of Performance) = ratio of the total heating capacity to the effective power input of the unit

**A35E5** = source : air in 35°C d.b. / plant : evaporation temperature (dew point) 5°C - superheating 5°C

**A7C50** = source : air in 7°C d.b. 6°C w.b. / plant : condensation temperature (dew point) 50°C - subcooling 5°C

**A7C45** = source : air in 7°C d.b. 6°C w.b. / plant : condensation temperature (dew point) 45°C - subcooling 5°C

**Acoustic performances**

Base setting up (AB)	19.1	22.1	26.1	30.1	35.1	40.1	
Sound power level	77	77	78	81	82	82	dB(A)
Sound pressure level at 1 meter	61	62	62	65	66	66	dB(A)
Sound pressure level at 5 meters	51	51	52	55	55	56	dB(A)
Sound pressure level at 10 meters	46	46	47	50	50	50	dB(A)
Low noise setting up (AS)	19.1	22.1	26.1	30.1	35.1	40.1	
Sound power level	74	74	75	78	79	79	dB(A)
Sound pressure level at 1 meter	58	59	59	62	63	63	dB(A)
Sound pressure level at 5 meters	48	48	49	52	53	53	dB(A)
Sound pressure level at 10 meters	43	43	44	47	48	48	dB(A)

The acoustic performances are referred to units operating in cooling mode at nominal conditions A35E5.

Unit placed in free field on reflecting surface (directional factor equal to 2).

The sound power level is measured according to ISO 9614 standard.

The sound pressure level is calculated according to ISO 3744 and is referred to a distance of 1/5/10 metres from the external surface of the unit.

**Technical data**

Unit	19.1	22.1	26.1	30.1	35.1	40.1	
Power supply	400 - 3N - 50						V-ph-Hz
Compressor type	scroll						-
N° compressors / N° refrigerant circuits	1 / 1						n°
Source side heat exchanger type	finned coil						-
Fans type	axial						-
N° fans	1						n°
Tank volume	5/8"						-
Hydraulic fittings	1" 1/8						-

**Electrical data**

Standard unit	19.1	22.1	26.1	30.1	35.1	40.1	
<b>FLA</b> - Full load current at maximum tolerated conditions	18,8	20,8	22,9	25,9	29,9	34,0	A
<b>FLI</b> - Full load power input at maximum tolerated conditions	10,8	12,1	13,4	15,8	18,4	21,0	kW
<b>MIC</b> - Maximum instantaneous current of the unit	98	114	121	129	144	178	A
<b>MIC SS</b> - Maximum instantaneous current of the unit with soft starter options	55	64	68	73	82	102	A

**Operating range**

Temperature	Unit type	Cooling		Heating		
		min	max	min	max	
Outdoor air inlet temperature	SR, SP	5	48	-15	42	°C
Evaporating temperature (dew point)	SR, SP	1	20	-	-	°C
Condensing temperature (dew point)	SP	-	-	35	60	°C

### CONTROL SYSTEM

The unit is managed by a microprocessor controller to which, through a wiring board, all the electrical loads and the control devices are connected. The user interface is realized by a display and four buttons that allow to view and, if necessary, modify all the operating parameters of the unit. It's available, as an accessory, a remote control that reports all the functionalities of the user interface placed on the unit.

The main functions available are :

- water or air temperature management (through set point adjustment)
- adaptive function
- climatic control in heating and in cooling mode (automatic set point adjustment according to outdoor air temperature)
- dynamic defrost cycle management according to outdoor air temperature
- alarm memory management and diagnostic

- fans management by means of continuous rotational speed control
- pump or fan management on the plant side
- integrative electrical heaters management in heating mode (2 step logic)
- compressor and pump or fan operating hours recording
- serial communication through Modbus protocol
- remote stand by
- remote cooling-heating
- general alarm digital output



### DIMENSIONS AND MINIMUM OPERATING AREA

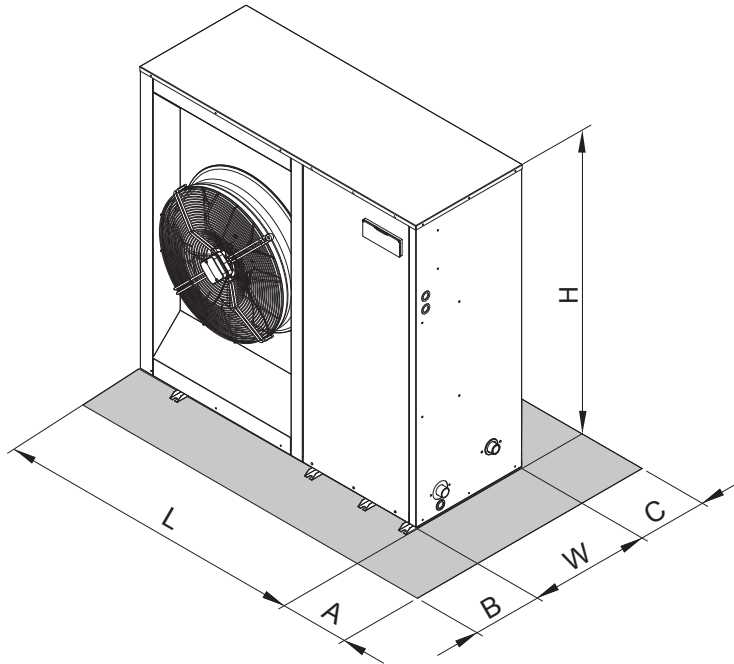

	19.1	22.1	26.1	30.1	35.1	40.1	
L	1494	1494	1494	1704	1704	1704	mm
W	576	576	576	576	576	576	mm
H	1453	1453	1453	1453	1453	1453	mm
A	400	400	400	400	400	400	mm
B	600	600	600	600	600	600	mm
C	200	200	200	200	200	200	mm
CMA unit - maximum weight operation	221	224	239	257	277	279	kg
CMA HE unit - maximum weight operation	236	239	259	279	302	304	kg



# > CMP - CMP HE

CONDENSING UNITS  
FOR INDOOR INSTALLATION



## Available range

### Unit type

- SR Condensing unit
- SP Reversible condensing unit (reversible on the refrigerant side)

### Versions

- VB Base Version

### Acoustic setting up

- AB Base setting up
- AS Low noise setting up

## Unit description

This series of condensing units satisfies the cooling and heating requirements of residential plants of small and medium size.

All the units are suitable for indoor installation and can be connected to a remote heat exchanger properly designed in order to transfer to the plant all the cooling (and heating for reversible units) power generated.

It is possible for example to connect direct expansion coils placed inside air handling units or remote plate heat exchangers placed inside technical rooms. In both cases the lack of outdoor hydraulic pipes eliminates the freezing problems and avoids brine solutions to be used.

The refrigerant circuit, contained in a compartment protected from the air flow to simplify the maintenance operations, is

equipped with scroll compressor mounted on damper supports, centrifugal fans (plug fan), finned coil made of copper pipes and aluminium louvered fins and shut off valves on the liquid line and on the gas line. The reversible units are moreover supplied with reverse cycle valve, thermostatic expansion valve (working in heating mode) and liquid receiver.

The circuit is protected by high and low pressure switches.

All the units are equipped with variable speed fans control that allows the units to operate with low outdoor temperatures in cooling and high outdoor temperature in heating and permits to reduce noise emissions in such operating conditions.

The low noise acoustic setting up (AS) is obtained, starting from the base setting up (AB), reducing the rotational speed of the fans and mounting sound jackets on the compressors.

All the units are supplied with an outdoor temperature sensor, already installed on the unit, in order to realize the climatic control.

All the units are provided with a phase presence and correct sequence controller device.

All the units are accurately built and individually tested in the factory.

All the units are supplied with refrigerant charge inside.

Only electric and refrigerant connections (between condensing unit and remote heat exchanger) are required for installation.

## Options

### Compressor starting

- standard (contactors)
- soft starter

### Electrical loads protection

- fuses
- thermal magnetic circuit breakers

### Compressor power factor correction

## Accessories

### Rubber vibration dampers

### Coil protection grille

### Remote control

### Modbus serial interface on RS485

### Programmer clock

### Phase sequence and voltage controller

### Remote plate heat exchanger

### Liquid line

**NET NOMINAL performances - CMP**

SR	Base setting up (AB)	19.1	22.1	26.1	30.1	35.1	40.1	
A35E5	Cooling capacity	21,6	24,0	28,0	33,5	38,7	43,6	kW
	Power input	6,79	7,45	8,72	10,7	12,2	13,8	kW
	EER	3,18	3,21	3,20	3,13	3,17	3,16	W/W
SR	Low noise setting up (AS)	19.1	22.1	26.1	30.1	35.1	40.1	
A35E5	Cooling capacity	20,7	23,0	26,9	32,2	37,2	41,9	kW
	Power input	7,33	8,05	9,40	11,5	13,2	14,9	kW
	EER	2,83	2,86	2,86	2,80	2,82	2,81	W/W
SP	Base setting up (AB)	19.1	22.1	26.1	30.1	35.1	40.1	
A35E5	Cooling capacity	21,2	23,5	27,4	32,8	37,9	42,8	kW
	Power input	6,72	7,38	8,63	10,6	12,1	13,7	kW
	EER	3,15	3,19	3,18	3,11	3,14	3,12	W/W
A7C50	Heating capacity	20,1	22,3	25,9	31,0	35,9	40,4	kW
	Power input	6,72	7,37	8,62	10,6	12,1	13,8	kW
	COP	2,99	3,03	3,00	2,92	2,97	2,93	W/W
A7C45	Heating capacity	22,2	24,6	28,6	34,2	39,6	44,6	kW
	Power input	5,92	6,49	7,59	9,34	10,6	12,1	kW
	COP	3,75	3,79	3,77	3,66	3,74	3,69	W/W
SP	Low noise setting up (AS)	19.1	22.1	26.1	30.1	35.1	40.1	
A35E5	Cooling capacity	20,3	22,6	26,4	31,5	36,4	41,0	kW
	Power input	7,26	7,97	9,31	11,4	13,1	14,8	kW
	EER	2,80	2,83	2,83	2,76	2,78	2,78	W/W
A7C50	Heating capacity	19,0	21,2	24,7	29,6	34,2	38,5	kW
	Power input	6,45	7,08	8,27	10,2	11,7	13,2	kW
	COP	2,94	3,00	2,98	2,90	2,93	2,91	W/W
A7C45	Heating capacity	21,0	23,4	27,2	32,6	37,7	42,5	kW
	Power input	5,68	6,23	7,29	8,98	10,3	11,7	kW
	COP	3,69	3,76	3,74	3,63	3,68	3,64	W/W

**NET NOMINAL performances - CMP HE**

SR	Base setting up (AB)	19.1	22.1	26.1	30.1	35.1	40.1	
A35E5	Cooling capacity	21,8	24,2	28,3	34,2	39,7	44,9	kW
	Power input	6,48	7,10	8,25	10,2	11,8	13,3	kW
	EER	3,36	3,41	3,43	3,36	3,38	3,38	W/W
SR	Low noise setting up (AS)	19.1	22.1	26.1	30.1	35.1	40.1	
A35E5	Cooling capacity	21,0	23,2	27,2	32,9	38,2	43,2	kW
	Power input	7,01	7,67	8,91	11,00	12,70	14,30	kW
	EER	2,99	3,03	3,05	3,00	3,01	3,02	W/W
SP	Base setting up (AB)	19.1	22.1	26.1	30.1	35.1	40.1	
A35E5	Cooling capacity	21,4	23,8	27,8	33,6	39,0	44,1	kW
	Power input	6,42	7,03	8,16	10,1	11,7	13,2	kW
	EER	3,33	3,39	3,40	3,34	3,33	3,33	W/W
A7C50	Heating capacity	20,3	22,5	26,2	31,8	36,9	41,8	kW
	Power input	6,43	7,02	8,16	10,1	11,7	13,2	kW
	COP	3,16	3,21	3,21	3,15	3,15	3,17	W/W
A7C45	Heating capacity	22,4	24,8	28,9	35,1	40,7	46,1	kW
	Power input	5,66	6,19	7,19	8,86	10,3	11,7	kW
	COP	3,96	4,01	4,02	3,96	3,95	3,94	W/W
SP	Low noise setting up (AS)	19.1	22.1	26.1	30.1	35.1	40.1	
A35E5	Cooling capacity	20,5	22,8	26,7	32,3	37,5	42,3	kW
	Power input	6,94	7,59	8,82	10,9	12,6	14,2	kW
	EER	2,96	3,00	3,02	2,97	2,98	2,98	W/W
A7C50	Heating capacity	19,2	21,3	25,0	30,2	35,0	39,7	kW
	Power input	6,16	6,75	7,83	9,66	11,2	12,7	kW
	COP	3,12	3,15	3,19	3,13	3,12	3,13	W/W
A7C45	Heating capacity	21,2	23,5	27,6	33,4	38,7	43,9	kW
	Power input	5,43	5,95	6,90	8,51	9,90	11,2	kW
	COP	3,91	3,95	4,00	3,92	3,91	3,92	W/W

The values are referred to units without options and accessories.

**EER** (Energy Efficiency Ratio) = ratio of the total cooling capacity to the effective power input of the unit

**COP** (Coefficient Of Performance) = ratio of the total heating capacity to the effective power input of the unit

**A35E5** = source : air in 35°C d.b. / plant : evaporation temperature (dew point) 5°C - superheating 5°C

**A7C50** = source : air in 7°C d.b. 6°C w.b. / plant : condensation temperature (dew point) 50°C - subcooling 5°C

**A7C45** = source : air in 7°C d.b. 6°C w.b. / plant : condensation temperature (dew point) 45°C - subcooling 5°C

### Acoustic performances

Base setting up (AB)	19.1	22.1	26.1	30.1	35.1	40.1	
Sound power level	76	76	77	80	81	81	dB(A)
Sound pressure level at 1 meter	60	60	61	64	65	65	dB(A)
Sound pressure level at 5 meters	50	50	51	54	55	55	dB(A)
Sound pressure level at 10 meters	45	45	46	49	49	50	dB(A)
Low noise setting up (AS)	19.1	22.1	26.1	30.1	35.1	40.1	
Sound power level	74	74	75	78	79	79	dB(A)
Sound pressure level at 1 meter	58	58	59	62	63	63	dB(A)
Sound pressure level at 5 meters	48	48	49	52	53	53	dB(A)
Sound pressure level at 10 meters	43	43	44	47	47	48	dB(A)

The acoustic performances are referred to units operating in cooling mode at nominal conditions A35E5.

Unit placed in free field on reflecting surface (directional factor equal to 2).

The sound power level is measured according to ISO 9614 standard.

The sound pressure level is calculated according to ISO 3744 and is referred to a distance of 1/5/10 metres from the external surface of the unit.

### Technical data

Unit	19.1	22.1	26.1	30.1	35.1	40.1	
Power supply	400 - 3N - 50						V-ph-Hz
Compressor type	scroll						-
N° compressors / N° refrigerant circuits	1 / 1						n°
Source side heat exchanger type	finned coil						-
Fans type	centrifugal (plug fan)						-
N° fans	1						n°
Tank volume	5/8"						-
Hydraulic fittings	1" 1/8						-

### Electrical data

Standard unit	19.1	22.1	26.1	30.1	35.1	40.1	
<b>FLA</b> - Full load current at maximum tolerated conditions	28,9	30,9	33,0	28,0	32,0	36,1	A
<b>FLI</b> - Full load power input at maximum tolerated conditions	13,0	14,3	15,6	16,8	19,4	22,0	kW
<b>MIC</b> - Maximum instantaneous current of the unit	108	124	131	131	146	180	A
<b>MIC SS</b> - Maximum instantaneous current of the unit with soft starter options	65	74	78	75	84	104	A

### Operating range

Temperature	Unit type	Cooling		Heating		°C
		min	max	min	max	
Outdoor air inlet temperature	SR, SP	5	48	-15	42	°C
Evaporating temperature (dew point)	SR, SP	1	20	-	-	°C
Condensing temperature (dew point)	SP	-	-	35	60	°C

## CONTROL SYSTEM

The unit is managed by a microprocessor controller to which, through a wiring board, all the electrical loads and the control devices are connected. The user interface is realized by a display and four buttons that allow to view and, if necessary, modify all the operating parameters of the unit. It's available, as an accessory, a remote control that reports all the functionalities of the user interface placed on the unit.

The main functions available are :

- water or air temperature management (through set point adjustment)
- adaptive function
- climatic control in heating and in cooling mode (automatic set point adjustment according to outdoor air temperature)
- dynamic defrost cycle management according to outdoor air temperature
- alarm memory management and diagnostic

- fans management by means of continuous rotational speed control
- pump or fan management on the plant side
- integrative electrical heaters management in heating mode (2 step logic)
- compressor and pump or fan operating hours recording
- serial communication through Modbus protocol
- remote stand by
- remote cooling-heating
- general alarm digital output



## DIMENSIONS AND MINIMUM OPERATING AREA

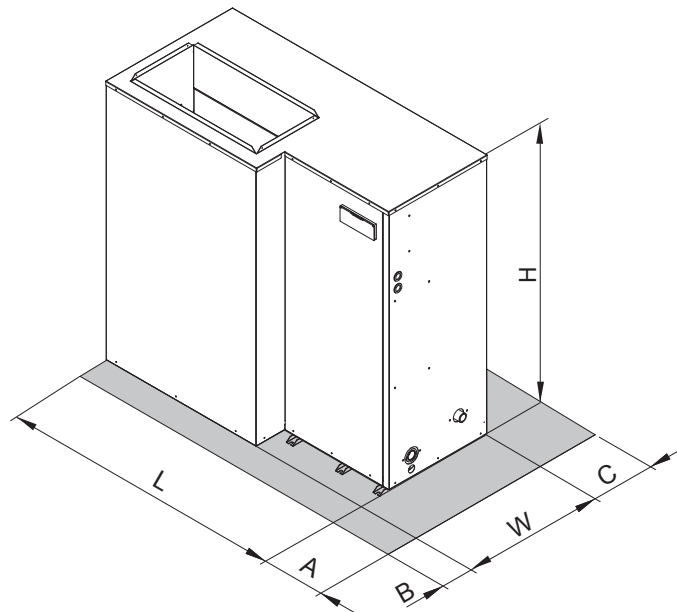



# > CGA

## CONDENSING UNITS FOR OUTDOOR INSTALLATION



### Available range

#### Unit type

- SR Condensing unit
- SP Heat pump condensing unit (reversible on the refrigerant side)

#### Version

- VB Base version
- VD Desuperheater version
- VR Total recovery version

#### Acoustic setting up

- AB Base setting up
- AS Low noise setting up
- AX eXtra low noise setting up

#### Source temperature level

- M Medium temperature level
- A High temperature level

### Unit description

This series of condensing units satisfies the cooling and heating requirements of residential plants of medium size.

All the units are suitable for outdoor installation and can be connected to a remote heat exchanger properly designed in order to transfer to the plant all the cooling (and heating for reversible units) power generated.

The refrigerant circuit, contained in a compartment protected from the air flow to simplify the maintenance operations, is equipped with scroll compressors mounted on damper supports, thermostatic expansion valve (only for SP), reverse

cycle valve, axial fans with safety protection grilles, finned coil made of copper pipes and aluminium louvered fins with sub-cooling section. The circuit is protected by a safety gas valve, high and low pressure switches.

All the units can be equipped with variable speed fans control that allows the units to operate with low outdoor temperatures in cooling and high outdoor temperature in heating and permits to reduce noise emissions in such operating conditions.

The low noise acoustic setting up (AS) is obtained, starting from the base setting up (AB), reducing the rotational speed of the fans and mounting sound jackets on the compressors and the technical compartment is clad with soundproofing material of suitable thickness.

The eXtra low noise acoustic setting up (AX) is obtained, starting from the low noise setting up (AS), further reducing the rotational speed of the fans and using finned coil with bigger surface.

All the units are supplied with a management and control electrical panel containing general switch, phase presence and correct sequence controller, microprocessor controller with display and all the other electrical components with IP54 minimum protection degree.

All the units are accurately built and individually tested in the factory.

All the units are supplied with refrigerant charge inside.

Only electric and refrigerant connections (between condensing unit and remote heat exchanger) are required for installation.

### Options

#### Compressor starting

- standard (contactors)
- soft starter

#### Fans control

- on-off control
- modulating control (condensation / evaporation control)

#### Compressor power factor correction

#### Electrical load protection

- fuses
- thermal magnetic circuit breakers

#### Coil condensate tray

### Accessories

#### Rubber vibration dampers

#### Spring vibration dampers

#### Coil protection grilles

#### Remote control

#### Modbus serial interface on RS485

#### Programmer clock

#### Phase sequence and voltage controller

#### Low temperature kit (standard for SP)

#### High and low pressure gauges

#### High temperature thermostat

#### Coil shut off valves

#### Outdoor air sensor

#### Remote plate heat exchanger

#### Liquid line

**NOMINAL performances**

SR	Base setting up (AB)	40.2	50.2	60.2	70.2	80.2	90.2	100.2	115.2	130.2	145.2	160.2	180.2	200.2	
A35E5	Cooling capacity	48,9	57,8	63,3	74,3	85,0	98,3	110	121	136	154	171	194	216	kW
	Power input	15,5	18,4	20,5	23,7	27,6	32,1	35,5	39,4	44,5	50,8	56,3	63,7	70,6	kW
	EER	3,15	3,14	3,09	3,14	3,08	3,06	3,10	3,07	3,06	3,03	3,04	3,05	3,06	W/W
SR	Low noise setting up (AS)	40.2	50.2	60.2	70.2	80.2	90.2	100.2	115.2	130.2	145.2	160.2	180.2	200.2	
A35E5	Cooling capacity	47,4	56,1	61,3	72,0	82,4	95,3	106	118	132	150	165	189	210	kW
	Power input	16,1	19,2	21,3	24,6	28,8	33,4	36,9	41,0	46,3	52,8	58,6	66,2	73,4	kW
	EER	2,94	2,92	2,88	2,93	2,86	2,85	2,87	2,88	2,85	2,84	2,82	2,85	2,86	W/W
SR	eXtra low noise setting up (AX)	40.2	50.2	60.2	70.2	80.2	90.2	100.2	115.2	130.2	145.2	160.2	180.2	200.2	
A35E5	Cooling capacity	46,3	54,8	59,9	70,4	80,5	93,1	104	114	129	146	162	184	204	kW
	Power input	16,2	19,6	21,9	25,1	29,6	32,5	38,0	42,2	47,7	53,8	59,8	68,1	75,5	kW
	EER	2,86	2,80	2,74	2,80	2,72	2,86	2,74	2,70	2,70	2,71	2,71	2,70	2,70	W/W
SP	Base setting up (AB)	40.2	50.2	60.2	70.2	80.2	90.2	100.2	115.2	130.2	145.2	160.2	180.2	200.2	
A35E5	Cooling capacity	47,3	57,1	62,1	72,6	80,0	96,3	107	119	132	149	166	192	214	kW
	Power input	15,3	18,6	20,4	23,8	26,7	31,9	35,3	39,3	43,9	49,7	55,6	62,7	70,3	kW
	EER	3,09	3,07	3,04	3,05	3,00	3,02	3,03	3,03	3,01	3,00	2,99	3,06	3,04	W/W
A7C50	Heating capacity	47,8	57,5	62,6	73,8	82,3	98,7	109	124	135	153	171	195	214	kW
	Power input	15,3	18,5	20,3	23,7	26,9	32,6	35,0	40,0	43,7	50,5	55,4	63,4	69,8	kW
	COP	3,12	3,11	3,08	3,11	3,06	3,03	3,11	3,10	3,09	3,03	3,09	3,08	3,07	W/W
A7C45	Heating capacity	52,6	63,3	68,9	81,2	90,5	109	120	136	149	168	188	215	235	kW
	Power input	13,5	16,3	17,9	20,9	23,7	28,7	30,8	35,2	38,5	44,4	48,8	55,8	61,4	kW
	COP	3,90	3,88	3,85	3,89	3,82	3,80	3,90	3,86	3,87	3,78	3,85	3,85	3,83	W/W
SP	Low noise setting up (AS)	40.2	50.2	60.2	70.2	80.2	90.2	100.2	115.2	130.2	145.2	160.2	180.2	200.2	
A35E5	Cooling capacity	45,4	54,9	59,6	69,7	76,8	92,4	103	114	126	143	160	185	205	kW
	Power input	15,9	19,8	21,6	25,2	28,3	33,8	37,4	41,6	46,6	52,7	59,0	66,4	74,5	kW
	EER	2,86	2,77	2,76	2,77	2,71	2,73	2,75	2,74	2,70	2,71	2,71	2,79	2,75	W/W
A7C50	Heating capacity	46,6	56,0	61,1	71,9	80,2	96,2	106	121	132	149	167	190	209	kW
	Power input	14,6	17,7	19,4	22,6	25,7	31,1	33,4	38,2	41,7	48,2	52,9	60,5	66,7	kW
	COP	3,19	3,16	3,15	3,18	3,12	3,09	3,17	3,17	3,17	3,09	3,16	3,14	3,13	W/W
A7C45	Heating capacity	51,3	61,6	67,2	79,1	88,2	106	117	133	145	164	184	209	230	kW
	Power input	12,8	15,6	17,1	19,9	22,6	27,4	29,4	33,6	36,7	42,4	46,6	53,2	58,7	kW
	COP	4,01	3,95	3,93	3,97	3,90	3,87	3,98	3,96	3,95	3,87	3,95	3,93	3,92	W/W
SP	eXtra low noise setting up (AX)	40.2	50.2	60.2	70.2	80.2	90.2	100.2	115.2	130.2	145.2	160.2	180.2	200.2	
A35E5	Cooling capacity	44,5	53,7	58,4	68,3	75,3	90,5	101	111	124	140	157	180	201	kW
	Power input	17,0	20,9	22,8	26,6	29,9	35,7	39,5	44,0	49,2	55,6	62,3	70,3	78,7	kW
	EER	2,62	2,57	2,56	2,57	2,52	2,54	2,56	2,52	2,52	2,52	2,52	2,56	2,55	W/W
A7C50	Heating capacity	44,9	54,0	58,9	69,4	77,4	92,8	103	117	127	144	161	183	201	kW
	Power input	13,9	16,8	18,5	21,6	24,5	29,7	31,9	36,4	39,8	46,0	50,4	57,7	63,5	kW
	COP	3,23	3,21	3,18	3,21	3,16	3,12	3,23	3,21	3,19	3,13	3,19	3,17	3,17	W/W
A7C45	Heating capacity	49,4	59,4	64,8	76,3	85,1	102	113	129	140	158	177	201	221	kW
	Power input	12,2	14,8	16,3	19,0	21,6	26,1	28,1	32,0	35,0	40,5	44,4	50,8	55,9	kW
	COP	4,05	4,01	3,98	4,02	3,94	3,91	4,02	4,03	4,00	3,90	3,99	3,96	3,95	W/W

The values are referred to units without options and accessories.  
**EER** (Energy Efficiency Ratio) = ratio of the total cooling capacity to the effective power input of the unit  
**COP** (Coefficient Of Performance) = ratio of the total heating capacity to the effective power input of the unit

**A35E5** = source : air in 35°C d.b. / plant : evaporation temperature (dew point) 5°C - superheating 5°C

**A7C50** = source : air in 7°C d.b. 6°C w.b. / plant : condensation temperature (dew point) 50°C - subcooling 5°C

**A7C45** = source : air in 7°C d.b. 6°C w.b. / plant : condensation temperature (dew point) 45°C - subcooling 5°C

### Acoustic performances

Base setting up (AB)	40.2	50.2	60.2	70.2	80.2	90.2	100.2	115.2	130.2	145.2	160.2	180.2	200.2	
Sound power level	82	82	83	84	84	85	85	85	86	87	87	88	88	dB(A)
Sound pressure level at 1 meter	64	64	65	66	66	67	67	67	68	69	69	69	69	dB(A)
Sound pressure level at 5 meters	55	55	56	57	57	58	58	58	59	60	60	61	61	dB(A)
Sound pressure level at 10 meters	50	50	51	52	52	53	53	53	54	55	55	56	56	dB(A)
Low noise setting up (AS)	40.2	50.2	60.2	70.2	80.2	90.2	100.2	115.2	130.2	145.2	160.2	180.2	200.2	
Sound power level	79	79	80	81	81	82	82	82	83	84	84	85	85	dB(A)
Sound pressure level at 1 meter	61	61	62	63	63	64	64	64	65	66	66	66	66	dB(A)
Sound pressure level at 5 meters	52	52	53	54	54	55	55	55	56	57	57	58	58	dB(A)
Sound pressure level at 10 meters	47	47	48	49	49	50	50	50	51	52	52	53	53	dB(A)
eXtra low noise setting up (AX)	40.2	50.2	60.2	70.2	80.2	90.2	100.2	115.2	130.2	145.2	160.2	180.2	200.2	
Sound power level	77	77	78	79	79	80	80	80	81	82	82	83	83	dB(A)
Sound pressure level at 1 meter	59	59	60	61	61	62	62	62	63	64	64	64	64	dB(A)
Sound pressure level at 5 meters	50	50	51	52	52	53	53	53	54	55	55	56	56	dB(A)
Sound pressure level at 10 meters	45	45	46	47	47	48	48	48	49	50	50	51	51	dB(A)

The values are referred to units without options and accessories.

The acoustic performances are referred to units operating in cooling mode at nominal conditions A35E5.

Unit placed in free field on reflecting surface (directional factor equal to 2).

The sound power level is measured according to ISO 9614 standard.

The sound pressure level is calculated according to ISO 3744 and is referred to a distance of 1/5/10 metres from the external surface of the unit.

### Technical data

Unit	40.2	50.2	60.2	70.2	80.2	90.2	100.2	115.2	130.2	145.2	160.2	180.2	200.2	
Power supply	400 - 3+N - 50					400 - 3 - 50					V-ph-Hz			
Compressor type	scroll													-
N° compressors / N° refrigerant circuits	2 / 1													n°
Source side heat exchanger type	finned coil													-
Fans type	axial													-
N° fans	2	3			2			3	4			n°		
Liquid line connection	7/8"			1 1/8"			1 3/8"						-	
Gas line connection	1 5/8"			2 1/8"									-	

### Electrical data

Standard unit	40.2	50.2	60.2	70.2	80.2	90.2	100.2	115.2	130.2	145.2	160.2	180.2	200.2	
<b>FLA</b> - Full load current at maximum tolerated conditions	40,2	45,7	53,3	58,7	69,6	75,5	90,0	97,9	106	123	136	159	170	A
<b>FLI</b> - Full load power input at maximum tolerated conditions	21,6	24,4	28,4	31,0	36,2	44,0	55,0	60,5	66,0	75,7	83,3	95,4	103	kW
<b>MIC</b> - Maximum instantaneous current of the unit	134	143	149	173	213	264	259	267	267	348	361	355	391	A
<b>MIC SS</b> - Maximum instantaneous current of the unit with soft starter options	89,3	96,3	101	117	143	174	175	183	183	200	246	248	272	A

### Operative range

Temperature	Unit type	Cooling		Heating		°C
		min	max	min	max	
Outdoor air inlet temperature	SR, SP	-10*	48	-10	40*	°C
Evaporating temperature (dew point)	SR, SP	1	20	-	-	°C
Condensing temperature (dew point)	SP	-	-	35	60	°C
Water outlet temperature (VD)	SR, SP	30	70	30	70	(°C)
Water outlet temperature (VR)	SR	30	55	-	-	(°C)

\* with fans modulating control option (condensation / evaporation control)

## VD and VR versions

These units allow to recover the heating power, otherwise wasted on air, through an additional heat exchanger.

The **Desuperheater Version (VD)** allow the hot water production at temperatures between 30 and 70°C through the partial heat recovery of the condensation heat.

The **Total Recovery Version (VR)** allows the cold water production and, at the same time, the hot water production at temperatures between 30 and 55°C through the total recovery of the condensation heat

### Desupeheater Version (VD) - NOMINAL performances

SR	Base setting up (AB)	40.2	50.2	60.2	70.2	80.2	90.2	100.2	115.2	130.2	145.2	160.2	180.2	200.2	
A35E5 - W45	Cooling capacity	50,9	60,1	65,8	77,3	88,4	102	115	126	142	161	177	202	225	kW
	Total power input	15,1	17,9	19,8	23,0	26,8	31,1	34,4	38,2	43,1	49,3	54,7	61,8	68,4	kW
	<b>EER</b>	<b>3,37</b>	<b>3,36</b>	<b>3,32</b>	<b>3,36</b>	<b>3,30</b>	<b>3,28</b>	<b>3,34</b>	<b>3,30</b>	<b>3,29</b>	<b>3,27</b>	<b>3,24</b>	<b>3,27</b>	<b>3,29</b>	W/W
A35E5 - W45	Heating recovery capacity	14,8	17,4	19,1	22,4	25,6	29,6	33,2	36,5	41,0	46,6	51,5	58,6	65,1	kW
	Water flow rate recovery	0,70	0,83	0,91	1,07	1,22	1,42	1,59	1,74	1,96	2,23	2,46	2,80	3,11	l/s
	Water pressure drop recovery	7	11	13	17	22	18	22	12	16	20	24	20	24	kPa
SP	Base setting up (AB)	40.2	50.2	60.2	70.2	80.2	90.2	100.2	115.2	130.2	145.2	160.2	180.2	200.2	
A35E5 - W45	Cooling capacity	49,2	59,4	64,6	75,5	83,2	100	111	124	137	155	173	200	222	kW
	Total power input	14,9	18,1	19,8	23,1	25,9	30,9	34,2	38,1	42,6	48,2	54,0	60,8	68,1	kW
	<b>EER</b>	<b>3,30</b>	<b>3,28</b>	<b>3,26</b>	<b>3,27</b>	<b>3,21</b>	<b>3,24</b>	<b>3,25</b>	<b>3,25</b>	<b>3,22</b>	<b>3,22</b>	<b>3,20</b>	<b>3,29</b>	<b>3,26</b>	W/W
A35E5 - W45	Heating recovery capacity	14,3	17,2	18,7	21,9	24,1	29,1	32,2	35,8	39,7	45,0	50,2	58,0	64,5	kW
	Water flow rate recovery	0,68	0,82	0,89	1,05	1,15	1,39	1,54	1,71	1,90	2,15	2,40	2,77	3,08	l/s
	Water pressure drop recovery	7	11	12	17	20	17	20	12	15	19	23	20	23	kPa

### Total Recovery Version (VR) - NOMINAL performances

SR	Base setting up (AB)	40.2	50.2	60.2	70.2	80.2	90.2	100.2	115.2	130.2	145.2	160.2	180.2	200.2	
A35E5 - W45	Cooling capacity	50,9	60,1	65,8	77,3	88,4	102	115	126	142	161	177	202	225	kW
	Total power input	14,9	17,7	19,6	22,7	26,5	30,8	34,1	37,8	42,7	48,8	54,1	61,2	67,7	kW
	<b>EER</b>	<b>3,42</b>	<b>3,40</b>	<b>3,36</b>	<b>3,41</b>	<b>3,34</b>	<b>3,31</b>	<b>3,37</b>	<b>3,33</b>	<b>3,33</b>	<b>3,30</b>	<b>3,27</b>	<b>3,30</b>	<b>3,32</b>	W/W
A35E5 - W45	Heating recovery capacity	65,0	76,9	84,5	98,9	114	131	147	162	182	207	229	260	289	kW
	Water flow rate recovery	3,11	3,67	4,04	4,73	5,43	6,28	7,02	7,73	8,70	9,89	10,9	12,4	13,8	l/s
	Water pressure drop recovery	41	57	48	53	59	58	62	56	61	61	62	65	65	kPa

Data declared according to EN 14511. The values are referred to units without options and accessories.

**EER** (Energy Efficiency Ratio) = ratio of the total cooling capacity to the effective power input of the unit

**HRE** (Heat Recovery Efficiency) = ratio of the total capacity of the system (heating plus cooling capacity) to the effective power input

**A35W7 - W45** = source : air in 35°C d.b. / plant : water in 12°C out 7°C / Recovery : water in 40°C out 45°C

## CONTROL SYSTEM

The units are equipped with a controller designed to ensure energy saving and unit efficiency. Available functions :

- Adaptive function
- Dynamic defrost
- Sound management
- Climatic control in heating and in cooling mode
- Economy function
- Demand limit
- Integrative heating
- Remote stand by
- Remote cooling-heating



## DIMENSIONS - MINIMUM OPERATING AREA - WEIGHT

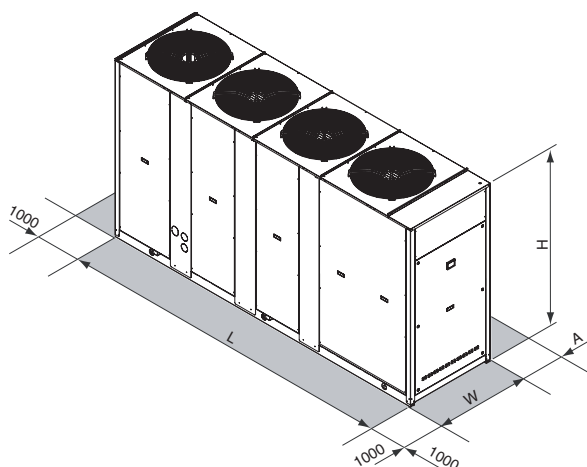

	40.2	50.2	60.2	70.2	80.2	90.2	100.2	115.2	130.2	145.2	160.2	180.2	200.2	
L			2501				3343			3343		4097		mm
W			954				1104			1104		1104		mm
H			1930				1793			2193		2193		mm
A				1600							2000			mm
Operating maximum weight	635	639	639	680	705	953	1034	1065	1181	1240	1292	1435	1481	kg



# > CGA HE

## CONDENSING UNITS FOR OUTDOOR INSTALLATION



ADAPTIVE  
FUNCTION



### Available range

#### Unit type

- SR Condensing unit
- SP Heat pump condensing unit (reversible on the refrigerant side)

#### Version

- VB Base version
- VD Desuperheater version
- VR Total recovery version

#### Acoustic setting up

- AB Base setting up
- AS Low noise setting up
- AX eXtra low noise setting up

#### Source temperature level

- M Medium temperature level
- A High temperature level

### Unit description

This series of condensing units satisfies the cooling and heating requirements of residential plants of medium size.

All the units are suitable for outdoor installation and can be connected to a remote heat exchanger properly designed in order to transfer to the plant all the cooling (and heating for reversible units) power generated.

The refrigerant circuit, contained in a compartment protected from the air flow to simplify the maintenance operations, is equipped with scroll compressors mounted on damper supports, thermostatic expansion valve (only for SP), reverse cycle valve, axial fans with safety protec-

tion grilles, finned coil made of copper pipes and aluminium louvered fins with sub-cooling section. The circuit is protected by a safety gas valve, high and low pressure switches.

All the units can be equipped with variable speed fans control that allows the units to operate with low outdoor temperatures in cooling and high outdoor temperature in heating and permits to reduce noise emissions in such operating conditions.

The low noise acoustic setting up (AS) is obtained, starting from the base setting up (AB), reducing the rotational speed of the fans and mounting sound jackets on the compressors and the technical compartment is clad with soundproofing material of suitable thickness.

The eXtra low noise acoustic setting up (AX) is obtained, starting from the low noise setting up (AS), further reducing the rotational speed of the fans and using finned coil with bigger surface.

All the units are supplied with a management and control electrical panel containing general switch, phase presence and correct sequence controller, microprocessor controller with display and all the other electrical components with IP54 minimum protection degree.

All the units are accurately built and individually tested in the factory.

All the units are supplied with refrigerant charge inside.

Only electric and refrigerant connections (between condensing unit and remote heat exchanger) are required for installation.

### Options

#### Compressor starting

- standard (contactors)
- soft starter

#### Fans control

- on-off control
- modulating control (condensation / evaporation control)

#### Compressor power factor correction

#### Electrical load protection

- fuses
- thermal magnetic circuit breakers

#### Coil condensate tray

### Accessories

#### Rubber vibration dampers

#### Spring vibration dampers

#### Coil protection grilles

#### Remote control

#### Modbus serial interface on RS485

#### Programmer clock

#### Phase sequence and voltage controller

#### Low temperature kit (standard for SP)

#### High and low pressure gauges

#### High temperature thermostat

#### Coil shut off valves

#### Outdoor air sensor

#### Remote plate heat exchanger

#### Liquid line

**NOMINAL performances**

SR	Base setting up (AB)	40.2	50.2	60.2	70.2	80.2	90.2	100.2	115.2	130.2	145.2	160.2	180.2	
A35E5	Cooling capacity	51,2	60,7	68,5	76,7	90,5	103,0	116	131	145	166	188	214	kW
	Power input	14,8	17,0	19,7	21,8	27,0	30,9	34,3	38,3	42,3	49,5	54,8	63,9	kW
	EER	3,46	3,57	3,48	3,52	3,35	3,33	3,38	3,42	3,43	3,35	3,43	3,35	W/W
SR	Low noise setting up (AS)	40.2	50.2	60.2	70.2	80.2	90.2	100.2	115.2	130.2	145.2	160.2	180.2	
A35E5	Cooling capacity	48,8	57,9	65,2	73,1	86,3	98,2	110	124	138	159	179	204	kW
	Power input	15,4	17,7	20,5	22,7	27,5	31,8	35,4	39,6	43,9	51,0	56,8	65,7	kW
	EER	3,17	3,27	3,18	3,22	3,14	3,09	3,11	3,13	3,14	3,12	3,15	3,11	W/W
SR	eXtra low noise setting up (AX)	40.2	50.2	60.2	70.2	80.2	90.2	100.2	115.2	130.2	145.2	160.2	180.2	
A35E5	Cooling capacity	48,0	56,8	64,2	71,8	84,8	96,6	108	122	136	156	176	200	kW
	Power input	15,6	18,0	20,7	23,0	27,8	32,2	35,8	40,2	44,7	51,5	57,4	66,4	kW
	EER	3,08	3,16	3,10	3,12	3,05	3,00	3,02	3,03	3,04	3,03	3,07	3,01	W/W
SP	Base setting up (AB)	40.2	50.2	60.2	70.2	80.2	90.2	100.2	115.2	130.2	145.2	160.2	180.2	
A35E5	Cooling capacity	49,1	58,2	65,9	73,7	88,2	100,2	112	125	139	160	180	207	kW
	Power input	14,5	16,9	19,3	21,5	26,5	30,0	33,6	37,5	41,4	48,1	53,8	62,2	kW
	EER	3,39	3,44	3,41	3,43	3,33	3,34	3,33	3,33	3,36	3,33	3,35	3,33	W/W
A7C50	Heating capacity	49,2	58,0	65,6	73,6	87,9	99,8	112	125	140	160	180	206	kW
	Power input	15,3	17,8	20,4	22,9	27,4	31,0	34,8	39,0	43,5	50,0	55,9	64,2	kW
	COP	3,22	3,26	3,22	3,21	3,21	3,22	3,22	3,21	3,22	3,20	3,22	3,21	W/W
A7C45	Heating capacity	54,1	63,8	72,2	81,0	96,7	110	123	138	154	176	198	227	kW
	Power input	13,5	15,7	18,0	20,2	24,1	27,3	30,6	34,3	38,3	44,0	49,2	56,5	kW
	COP	4,01	4,06	4,01	4,01	4,01	4,03	4,02	4,02	4,02	4,00	4,02	4,02	W/W
SP	Low noise setting up (AS)	40.2	50.2	60.2	70.2	80.2	90.2	100.2	115.2	130.2	145.2	160.2	180.2	
A35E5	Cooling capacity	46,8	55,4	62,7	70,2	84,0	95,5	107	119	133	152	172	198	kW
	Power input	15,1	17,6	20,0	22,4	27,0	30,8	34,6	38,8	43,0	49,5	55,7	63,9	kW
	EER	3,10	3,15	3,14	3,13	3,11	3,10	3,09	3,07	3,09	3,07	3,09	3,10	W/W
A7C50	Heating capacity	47,9	56,5	63,9	71,7	85,6	97,2	109	122	136	156	175	201	kW
	Power input	14,7	17,2	19,7	22,2	26,0	29,6	33,4	37,5	42,0	47,9	53,7	61,4	kW
	COP	3,26	3,28	3,24	3,23	3,29	3,28	3,26	3,25	3,24	3,26	3,26	3,27	W/W
A7C45	Heating capacity	52,7	62,2	70,3	78,9	94,2	107	120	134	150	172	193	221	kW
	Power input	12,9	15,1	17,3	19,5	22,9	26,0	29,4	33,0	37,0	42,2	47,3	54,0	kW
	COP	4,09	4,12	4,06	4,05	4,11	4,12	4,08	4,06	4,05	4,08	4,08	4,09	W/W
SP	eXtra low noise setting up (AX)	40.2	50.2	60.2	70.2	80.2	90.2	100.2	115.2	130.2	145.2	160.2	180.2	
A35E5	Cooling capacity	46,0	54,5	61,7	69,0	82,6	93,9	105	118	131	150	168	194	kW
	Power input	15,3	17,9	20,3	22,7	27,3	31,2	35,1	39,4	43,7	50,0	56,3	64,6	kW
	EER	3,01	3,04	3,04	3,04	3,03	3,01	2,99	2,99	3,00	3,00	2,98	3,00	W/W
A7C50	Heating capacity	47,4	55,8	63,1	70,8	84,6	96,0	108	120	135	154	173	198	kW
	Power input	14,5	16,9	19,3	21,7	25,5	29,0	32,7	36,8	41,2	46,8	52,6	60,1	kW
	COP	3,27	3,30	3,27	3,26	3,32	3,31	3,30	3,26	3,28	3,29	3,29	3,29	W/W
A7C45	Heating capacity	52,1	61,4	69,4	77,9	93,1	106	119	132	149	169	190	218	kW
	Power input	12,8	14,9	17,0	19,1	22,4	25,5	28,8	32,4	36,3	41,2	46,3	52,9	kW
	COP	4,07	4,12	4,08	4,08	4,16	4,16	4,13	4,07	4,10	4,10	4,10	4,12	W/W

The values are referred to units without options and accessories.

**EER** (Energy Efficiency Ratio) = ratio of the total cooling capacity to the effective power input of the unit

**COP** (Coefficient Of Performance) = ratio of the total heating capacity to the effective power input of the unit

**A35E5** = source : air in 35°C d.b. / plant : evaporation temperature (dew point) 5°C - superheating 5°C

**A7C50** = source : air in 7°C d.b. 6°C w.b. / plant : condensation temperature (dew point) 50°C - subcooling 5°C

**A7C45** = source : air in 7°C d.b. 6°C w.b. / plant : condensation temperature (dew point) 45°C - subcooling 5°C

**Acoustic performances**

Base setting up (AB)	40.2	50.2	60.2	70.2	80.2	90.2	100.2	115.2	130.2	145.2	160.2	180.2	
Sound power level	82	82	83	84	85	85	85	85	86	87	87	88	dB(A)
Sound pressure level at 1 meter	64	64	65	66	67	67	67	67	68	69	69	69	dB(A)
Sound pressure level at 5 meters	55	55	56	57	58	58	58	58	59	60	60	61	dB(A)
Sound pressure level at 10 meters	50	50	51	52	53	53	53	53	54	55	55	56	dB(A)
Low noise setting up (AS)	40.2	50.2	60.2	70.2	80.2	90.2	100.2	115.2	130.2	145.2	160.2	180.2	
Sound power level	79	79	80	81	82	82	82	82	83	84	84	85	dB(A)
Sound pressure level at 1 meter	61	61	62	63	64	64	64	64	65	66	66	66	dB(A)
Sound pressure level at 5 meters	52	52	53	54	55	55	55	55	56	57	57	58	dB(A)
Sound pressure level at 10 meters	47	47	48	49	50	50	50	50	51	52	52	53	dB(A)
eXtra low noise setting up (AX)	40.2	50.2	60.2	70.2	80.2	90.2	100.2	115.2	130.2	145.2	160.2	180.2	
Sound power level	77	77	78	79	80	80	80	80	81	82	82	83	dB(A)
Sound pressure level at 1 meter	59	59	60	61	62	62	62	62	63	64	64	64	dB(A)
Sound pressure level at 5 meters	50	50	51	52	53	53	53	53	54	55	55	56	dB(A)
Sound pressure level at 10 meters	45	45	46	47	48	48	48	48	49	50	50	51	dB(A)

The values are referred to units without options and accessories.

The acoustic performances are referred to units operating in cooling mode at nominal conditions A35E5.

Unit placed in free field on reflecting surface (directional factor equal to 2).

The sound power level is measured according to ISO 9614 standard.

The sound pressure level is calculated according to ISO 3744 and is referred to a distance of 1/5/10 metres from the external surface of the unit.

**Technical data**

Unit	40.2	50.2	60.2	70.2	80.2	90.2	100.2	115.2	130.2	145.2	160.2	180.2	
Power supply	400 - 3+N - 50				400 - 3 - 50								V-ph-Hz
Compressor type					scroll								-
N° compressors / N° refrigerant circuits					2 / 1								n°
Source side heat exchanger type					finned coil								-
Fans type					axial								-
N° fans	2	3			2		3	4					n°
Liquid line connection	7/8"				1 1/8"		1 3/8"						-
Gas line connection	1 5/8"				2 1/8"						-		

**Electrical data**

Standard unit	40.2	50.2	60.2	70.2	80.2	90.2	100.2	115.2	130.2	145.2	160.2	180.2	
<b>FLA</b> - Full load current at maximum tolerated conditions	40,2	45,7	53,3	58,7	69,6	75,5	90,0	97,9	106	123	136	159	A
<b>FLI</b> - Full load power input at maximum tolerated conditions	21,6	24,4	28,4	31,0	36,2	44,0	55,0	60,5	66,0	75,7	83,3	95,4	kW
<b>MIC</b> - Maximum instantaneous current of the unit	134	143	149	173	213	264	259	267	267	348	361	355	A
<b>MIC SS</b> - Maximum instantaneous current of the unit with soft starter options	89,3	96,3	101	117	143	174	175	183	183	200	246	248	A

**Operative range**

Temperature	Unit type	Cooling		Heating		
		min	max	min	max	
Outdoor air inlet temperature	SR, SP	-10*	48	-15	40*	°C
Evaporating temperature (dew point)	SR, SP	1	20	-	-	°C
Condensing temperature (dew point)	SP	-	-	35	60	°C
Water outlet temperature (VD)	SR, SP	30	70	30	70	(°C)
Water outlet temperature (VR)	SR	30	55	-	-	(°C)

\* with fans modulating control option (condensation / evaporation control)

## VD and VR versions

These units allow to recover the heating power, otherwise wasted on air, through an additional heat exchanger.

The **Desuperheater Version (VD)** allow the hot water production at temperatures between 30 and 70°C through the partial heat recovery of the condensation heat.

The **Total Recovery Version (VR)** allows the cold water production and, at the same time, the hot water production at temperatures between 30 and 55°C through the total recovery of the condensation heat.

### Desupeheater Version (VD) - NOMINAL performances

SR	Base setting up (AB)	40.2	50.2	60.2	70.2	80.2	90.2	100.2	115.2	130.2	145.2	160.2	180.2	
A35E5 - W45	Cooling capacity	53,2	63,1	71,2	79,7	94,1	107	120	136	151	173	195	222	kW
	Total power input	14,4	16,5	19,1	21,1	26,2	30,0	33,2	37,2	41,1	48,0	53,2	62,0	kW
	<b>EER</b>	<b>3,69</b>	<b>3,82</b>	<b>3,73</b>	<b>3,78</b>	<b>3,59</b>	<b>3,57</b>	<b>3,61</b>	<b>3,66</b>	<b>3,67</b>	<b>3,60</b>	<b>3,67</b>	<b>3,58</b>	W/W
A35E5 - W45	Heating recovery capacity	15,4	18,3	20,7	23,1	27,3	31,1	34,9	39,4	43,6	50,2	56,7	64,5	kW
	Water flow rate recovery	0,74	0,87	0,99	1,10	1,30	1,48	1,67	1,88	2,09	2,40	2,71	3,08	l/s
	Water pressure drop recovery	8	12	15	18	25	20	24	14	18	24	29	24	kPa
SP	Base setting up (AB)	40.2	50.2	60.2	70.2	80.2	90.2	100.2	115.2	130.2	145.2	160.2	180.2	
A35E5 - W45	Cooling capacity	51,1	60,5	68,5	76,6	91,8	104	117	130	145	166	188	216	kW
	Total power input	14,1	16,4	18,7	20,8	25,7	29,1	32,6	36,4	40,2	46,6	52,2	60,3	kW
	<b>EER</b>	<b>3,62</b>	<b>3,69</b>	<b>3,66</b>	<b>3,68</b>	<b>3,57</b>	<b>3,57</b>	<b>3,59</b>	<b>3,57</b>	<b>3,61</b>	<b>3,56</b>	<b>3,60</b>	<b>3,58</b>	W/W
A35E5 - W45	Heating recovery capacity	14,8	17,6	19,9	22,2	26,6	30,2	33,9	37,8	42,0	48,2	54,4	62,5	kW
	Water flow rate recovery	0,71	0,84	0,95	1,06	1,27	1,44	1,62	1,81	2,01	2,30	2,60	2,99	l/s
	Water pressure drop recovery	7	11	14	17	24	19	22	13	17	22	27	23	kPa

### Total Recovery Version (VR) - NOMINAL performances

SR	Base setting up (AB)	40.2	50.2	60.2	70.2	80.2	90.2	100.2	115.2	130.2	145.2	160.2	180.2	
A35E5 - W45	Cooling capacity	53,2	63,1	71,2	79,7	94,1	107	120	136	151	173	195	222	kW
	Total power input	14,2	16,4	18,9	20,9	25,9	29,7	32,9	36,8	40,6	47,5	52,6	61,4	kW
	<b>EER</b>	<b>3,75</b>	<b>3,85</b>	<b>3,77</b>	<b>3,81</b>	<b>3,63</b>	<b>3,60</b>	<b>3,65</b>	<b>3,70</b>	<b>3,72</b>	<b>3,64</b>	<b>3,71</b>	<b>3,62</b>	W/W
A35E5 - W45	Heating recovery capacity	66,8	78,7	89,1	99,6	119	135	151	171	189	218	245	281	kW
	Water flow rate recovery	3,19	3,76	4,26	4,76	5,68	6,47	7,23	8,16	9,03	10,42	11,7	13,4	l/s
	Water pressure drop recovery	43	60	54	53	64	61	65	63	66	67	71	76	kPa

Data declared according to **EN 14511**. The values are referred to units without options and accessories.

**EER** (Energy Efficiency Ratio) = ratio of the total cooling capacity to the effective power input of the unit

**HRE** (Heat Recovery Efficiency) = ratio of the total capacity of the system (heating plus cooling capacity) to the effective power input

**A35W7 - W45** = source : air in 35°C d.b. / plant : water in 12°C out 7°C / Recovery : water in 40°C out 45°C

## CONTROL SYSTEM

The units are equipped with a controller designed to ensure energy saving and unit efficiency. Available functions :

- Adaptive function
- Dynamic defrost
- Sound management
- Climatic control in heating and in cooling mode
- Economy function
- Demand limit
- Integrative heating
- Remote stand by
- Remote cooling-heating



## DIMENSIONS - MINIMUM OPERATING AREA - WEIGHT

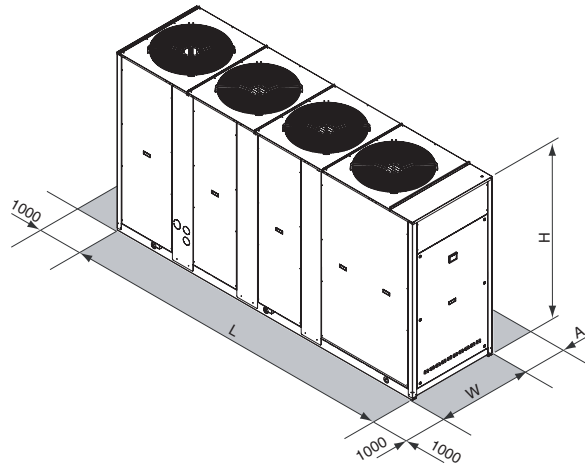

	40.2	50.2	60.2	70.2	80.2	90.2	100.2	115.2	130.2	145.2	160.2	180.2		
L		2501				3343			3343		4097			mm
W		954				1104			1104		1104			mm
H		1930				1793			2193		2193			mm
A		1600							2000					mm
Operating maximum weight	635	639	639	680	705	953	1034	1065	1181	1240	1292	1435	kg	





## CONDENSING UNITS FOR INDOOR INSTALLATION



### Available range

#### Unit type

- SR Condensing unit
- SP Heat pump condensing unit (reversible on the refrigerant side)

#### Version

- VB Base version
- VD Desuperheater version
- VR Total recovery version

#### Acoustic setting up

- AB Base setting up
- AS Low noise setting up

#### Source temperature level

- M Medium temperature level
- A High temperature level

### Unit description

This series of condensing units satisfies the cooling and heating requirements of residential plants of medium size.

All the units are suitable for outdoor installation and can be connected to a remote heat exchanger properly designed in order to transfer to the plant all the cooling (and heating for reversible units) power generated.

The refrigerant circuit, contained in a compartment protected from the air flow to simplify the maintenance operations, is equipped with scroll compressors mounted on damper supports, thermostatic expansion

valve (only for SP), reverse cycle valve, double inlet centrifugal fans with forward curved blades, finned coil made of copper pipes and aluminium louvered fins with subcooling section. The circuit is protected by a safety gas valve, high and low pressure switches.

All the units can be equipped with variable speed fans control that allows the units to operate with low outdoor temperatures in cooling and high outdoor temperature in heating and permits to reduce noise emissions in such operating conditions.

The low noise acoustic setting up (AS) is obtained, starting from the base setting up (AB), mounting sound jackets on the compressors and the technical compartment is clad with soundproofing material of suitable thickness.

All the units are supplied with a management and control electrical panel containing general switch, phase presence and correct sequence controller, microprocessor controller with display and all the other electrical components with IP54 minimum protection degree.

All the units are accurately built and individually tested in the factory.

All the units are supplied with refrigerant charge inside.

Only electric and refrigerant connections (between condensing unit and remote heat exchanger) are required for installation.

### Options

#### Compressor starting

- standard (contactors)
- soft starter

#### Fans control

- on-off control
- modulating control INVERTER (condensation / evaporation control)

#### Compressor power factor correction

#### Electrical load protection

- fuses
- thermal magnetic circuit breakers

#### Coil condensate tray

(standard for SP)

### Accessories

#### Rubber vibration dampers

#### Spring vibration dampers

#### Coil protection grilles

#### Remote control

#### Modbus serial interface on RS485

#### Programmer clock

#### Phase sequence and voltage controller

#### Low temperature kit (standard for SP)

#### High and low pressure gauges

#### High temperature thermostat

#### Coil shut off valves

#### Outdoor air sensor

#### Remote plate heat exchanger

#### Liquid line

**NOMINAL performances**

SR	Base setting up (AB)	40.2	50.2	60.2	70.2	80.2	90.2	100.2	115.2	130.2	145.2	160.2	180.2	200.2	
A35E5	Cooling capacity	48,9	57,8	63,3	74,3	85,0	98,3	110	121	136	154	171	194	216	kW
	Power input	15,5	18,4	20,5	23,7	27,6	32,1	35,5	39,4	44,5	50,8	56,3	63,7	70,6	kW
	EER	3,15	3,14	3,09	3,14	3,08	3,06	3,10	3,07	3,06	3,03	3,04	3,05	3,06	W/W
SR	Low noise setting up (AS)	40.2	50.2	60.2	70.2	80.2	90.2	100.2	115.2	130.2	145.2	160.2	180.2	200.2	
A35E5	Cooling capacity	48,9	57,8	63,3	74,3	85,0	98,3	110	121	136	154	171	194	216	kW
	Power input	15,5	18,4	20,5	23,7	27,6	32,1	35,5	39,4	44,5	50,8	56,3	63,7	70,6	kW
	EER	3,15	3,14	3,09	3,14	3,08	3,06	3,10	3,07	3,06	3,03	3,04	3,05	3,06	W/W
SP	Base setting up (AB)	40.2	50.2	60.2	70.2	80.2	90.2	100.2	115.2	130.2	145.2	160.2	180.2	200.2	
A35E5	Cooling capacity	47,3	57,1	62,1	72,6	80,0	96,3	107	119	132	149	166	192	214	kW
	Power input	15,3	18,6	20,4	23,8	26,7	31,9	35,3	39,3	43,9	49,7	55,6	62,7	70,3	kW
	EER	3,09	3,07	3,04	3,05	3,00	3,02	3,03	3,03	3,01	3,00	2,99	3,06	3,04	W/W
A7C50	Heating capacity	47,8	57,5	62,6	73,8	82,3	98,7	109	124	135	153	171	195	214	kW
	Power input	15,3	18,5	20,3	23,7	26,9	32,6	35,0	40,0	43,7	50,5	55,4	63,4	69,8	kW
	COP	3,12	3,11	3,08	3,11	3,06	3,03	3,11	3,10	3,09	3,03	3,09	3,08	3,07	W/W
A7C45	Heating capacity	52,6	63,3	68,9	81,2	90,5	109	120	136	149	168	188	215	235	kW
	Power input	13,5	16,3	17,9	20,9	23,7	28,7	30,8	35,2	38,5	44,4	48,8	55,8	61,4	kW
	COP	3,90	3,88	3,85	3,89	3,82	3,80	3,90	3,86	3,87	3,78	3,85	3,85	3,83	W/W
SP	Low noise setting up (AS)	40.2	50.2	60.2	70.2	80.2	90.2	100.2	115.2	130.2	145.2	160.2	180.2	200.2	
A35E5	Cooling capacity	47,3	57,1	62,1	72,6	80,0	96,3	107	119	132	149	166	192	214	kW
	Power input	15,3	18,6	20,4	23,8	26,7	31,9	35,3	39,3	43,9	49,7	55,6	62,7	70,3	kW
	EER	3,09	3,07	3,04	3,05	3,00	3,02	3,03	3,03	3,01	3,00	2,99	3,06	3,04	W/W
A7C50	Heating capacity	47,8	57,5	62,6	73,8	82,3	98,7	109	124	135	153	171	195	214	kW
	Power input	15,3	18,5	20,3	23,7	26,9	32,6	35,0	40,0	43,7	50,5	55,4	63,4	69,8	kW
	COP	3,12	3,11	3,08	3,11	3,06	3,03	3,11	3,10	3,09	3,03	3,09	3,08	3,07	W/W
A7C45	Heating capacity	52,6	63,3	68,9	81,2	90,5	109	120	136	149	168	188	215	235	kW
	Power input	13,5	16,3	17,9	20,9	23,7	28,7	30,8	35,2	38,5	44,4	48,8	55,8	61,4	kW
	COP	3,90	3,88	3,85	3,89	3,82	3,80	3,90	3,86	3,87	3,78	3,85	3,85	3,83	W/W

The values are referred to units without options and accessories.  
**EER** (Energy Efficiency Ratio) = ratio of the total cooling capacity to the effective power input of the unit  
**COP** (Coefficient Of Performance) = ratio of the total heating capacity to the effective power input of the unit

**A35E5** = source : air in 35°C d.b. / plant : evaporation temperature (dew point) 5°C - superheating 5°C  
**A7C50** = source : air in 7°C d.b. 6°C w.b. / plant : condensation temperature (dew point) 50°C - subcooling 5°C  
**A7C45** = source : air in 7°C d.b. 6°C w.b. / plant : condensation temperature (dew point) 45°C - subcooling 5°C

### Acoustic performances

Base setting up (AB)	40.2	50.2	60.2	70.2	80.2	90.2	100.2	115.2	130.2	145.2	160.2	180.2	200.2	
Sound power level	88	88	89	89	89	91	91	91	96	97	97	98	98	dB(A)
Sound pressure level at 1 meter	70	70	71	71	71	73	73	73	78	79	79	80	80	dB(A)
Sound pressure level at 5 meters	61	61	62	62	62	65	65	65	69	70	70	71	71	dB(A)
Sound pressure level at 10 meters	56	56	57	57	57	59	59	59	64	65	65	66	66	dB(A)
Low noise setting up (AS)	40.2	50.2	60.2	70.2	80.2	90.2	100.2	115.2	130.2	145.2	160.2	180.2	200.2	
Sound power level	85	85	86	86	86	88	88	88	93	94	94	95	95	dB(A)
Sound pressure level at 1 meter	67	67	68	68	68	70	70	70	75	76	76	77	77	dB(A)
Sound pressure level at 5 meters	58	58	59	59	59	62	62	62	66	67	67	68	68	dB(A)
Sound pressure level at 10 meters	53	53	54	54	54	56	56	56	61	62	62	63	63	dB(A)

The values are referred to units without options and accessories.

The acoustic performances are referred to units operating in cooling mode at nominal conditions A35E5.

Unit placed in free field on reflecting surface (directional factor equal to 2).

The sound power level is measured according to ISO 9614 standard.

The sound pressure level is calculated according to ISO 3744 and is referred to a distance of 1/5/10 metres from the external surface of the unit.

### Technical data

Unit	40.2	50.2	60.2	70.2	80.2	90.2	100.2	115.2	130.2	145.2	160.2	180.2	200.2	
Power supply	400 - 3 - 50													V-ph-Hz
Compressor type	scroll													-
N° compressors / N° refrigerant circuits	2 / 1													n°
Source side heat exchanger type	finned coil													-
Fans type	centrifugal													-
N° fans	1			2			3			4				n°
Liquid line connection	7/8"			1 1/8"						1 3/8"				-
Gas line connection	1 5/8"			2 1/8"										-

### Electrical data

Standard unit	40.2	50.2	60.2	70.2	80.2	90.2	100.2	115.2	130.2	145.2	160.2	180.2	200.2	
<b>FLA</b> - Full load current at maximum tolerated conditions	43,2	48,8	56,7	62,1	73,0	80,5	95,0	103	117	145	158	188	199	A
<b>FLI</b> - Full load power input at maximum tolerated conditions	25,2	28,0	33,0	35,6	40,8	47,3	58,3	63,8	72,8	88,7	96,3	113	120	kW
<b>MIC</b> - Maximum instantaneous current of the unit	137	147	152	177	216	269	264	272	278	370	383	384	420	A
<b>MIC SS</b> - Maximum instantaneous current of the unit with soft starter options	92,4	99,4	105	121	147	179	180	188	194	222	268	277	301	A

### Operative range

Temperature	Unit type	Cooling		Heating		
		min	max	min	max	
Outdoor air inlet temperature	SR, SP	-10*	48	-10	40*	°C
Evaporating temperature (dew point)	SR, SP	1	20	-	-	°C
Condensing temperature (dew point)	SP	-	-	35	60	°C
Water outlet temperature (VD)	SR, SP	30	70	30	70	(°C)
Water outlet temperature (VR)	SR	30	55	-	-	(°C)

\* with fans modulating control option (condensation / evaporation control)

### Aeraulic performance

Unit	40.2	50.2	60.2	70.2	80.2	90.2	100.2	115.2	130.2	145.2	160.2	180.2	200.2	
Available static head	150	150	150	150	150	150	150	150	150	150	150	150	150	Pa

## VD and VR versions

These units allow to recover the heating power, otherwise wasted on air, through an additional heat exchanger.

The **Desuperheater Version (VD)** allow the hot water production at temperatures between 30 and 70°C through the partial heat recovery of the condensation heat.

The **Total Recovery Version (VR)** allows the cold water production and, at the same time, the hot water production at temperatures between 30 and 55°C through the total recovery of the condensation heat.

### Desupeheater Version (VD) - NOMINAL performances

SR	Base setting up (AB)	40.2	50.2	60.2	70.2	80.2	90.2	100.2	115.2	130.2	145.2	160.2	180.2	200.2	
A35E5 - W45	Cooling capacity	50,9	60,1	65,8	77,3	88,4	102	115	126	142	161	177	202	225	kW
	Total power input	15,1	17,9	19,8	23,0	26,8	31,1	34,4	38,2	43,1	49,3	54,7	61,8	68,4	kW
	<b>EER</b>	<b>3,37</b>	<b>3,36</b>	<b>3,32</b>	<b>3,36</b>	<b>3,30</b>	<b>3,28</b>	<b>3,34</b>	<b>3,30</b>	<b>3,29</b>	<b>3,27</b>	<b>3,24</b>	<b>3,27</b>	<b>3,29</b>	<b>W/W</b>
	Heating recovery capacity	14,8	17,4	19,1	22,4	25,6	29,6	33,2	36,5	41,0	46,6	51,5	58,6	65,1	kW
	Water flow rate recovery	0,70	0,83	0,91	1,07	1,22	1,42	1,59	1,74	1,96	2,23	2,46	2,80	3,11	l/s
	Water pressure drop recovery	7	11	13	17	22	18	22	12	16	20	24	20	24	kPa
SP	Base setting up (AB)	40.2	50.2	60.2	70.2	80.2	90.2	100.2	115.2	130.2	145.2	160.2	180.2	200.2	
A35E5 - W45	Cooling capacity	49,2	59,4	64,6	75,5	83,2	100	111	124	137	155	173	200	222	kW
	Total power input	14,9	18,1	19,8	23,1	25,9	30,9	34,2	38,1	42,6	48,2	54,0	60,8	68,1	kW
	<b>EER</b>	<b>3,30</b>	<b>3,28</b>	<b>3,26</b>	<b>3,27</b>	<b>3,21</b>	<b>3,24</b>	<b>3,25</b>	<b>3,25</b>	<b>3,22</b>	<b>3,22</b>	<b>3,20</b>	<b>3,29</b>	<b>3,26</b>	<b>W/W</b>
	Heating recovery capacity	14,3	17,2	18,7	21,9	24,1	29,1	32,2	35,8	39,7	45,0	50,2	58,0	64,5	kW
	Water flow rate recovery	0,68	0,82	0,89	1,05	1,15	1,39	1,54	1,71	1,90	2,15	2,40	2,77	3,08	l/s
	Water pressure drop recovery	7	11	12	17	20	17	20	12	15	19	23	20	23	kPa

### Total Recovery Version (VR) - NOMINAL performances

SR	Base setting up (AB)	40.2	50.2	60.2	70.2	80.2	90.2	100.2	115.2	130.2	145.2	160.2	180.2	200.2	
A35E5 - W45	Cooling capacity	50,9	60,1	65,8	77,3	88,4	102	115	126	142	161	177	202	225	kW
	Total power input	14,9	17,7	19,6	22,7	26,5	30,8	34,1	37,8	42,7	48,8	54,1	61,2	67,7	kW
	<b>EER</b>	<b>3,42</b>	<b>3,40</b>	<b>3,36</b>	<b>3,41</b>	<b>3,34</b>	<b>3,31</b>	<b>3,37</b>	<b>3,33</b>	<b>3,33</b>	<b>3,30</b>	<b>3,27</b>	<b>3,30</b>	<b>3,32</b>	<b>W/W</b>
	Heating recovery capacity	65,0	76,9	84,5	98,9	114	131	147	162	182	207	229	260	289	kW
	Water flow rate recovery	3,11	3,67	4,04	4,73	5,43	6,28	7,02	7,73	8,70	9,89	10,9	12,4	13,8	l/s
	Water pressure drop recovery	41	57	48	53	59	58	62	56	61	61	62	65	65	kPa

Data declared according to EN 14511. The values are referred to units without options and accessories.

**EER** (Energy Efficiency Ratio) = ratio of the total cooling capacity to the effective power input of the unit

**HRE** (Heat Recovery Efficiency) = ratio of the total capacity of the system (heating plus cooling capacity) to the effective power input

**A35W7 - W45** = source : air in 35°C d.b. / plant : water in 12°C out 7°C / Recovery : water in 40°C out 45°C

## CONTROL SYSTEM

The units are equipped with a controller designed to ensure energy saving and unit efficiency. Available functions :

- Adaptive function
- Dynamic defrost
- Sound management
- Climatic control in heating and in cooling mode
- Economy function
- Demand limit
- Integrative heating
- Remote stand by
- Remote cooling-heating



## DIMENSIONS - MINIMUM OPERATING AREA - WEIGHT

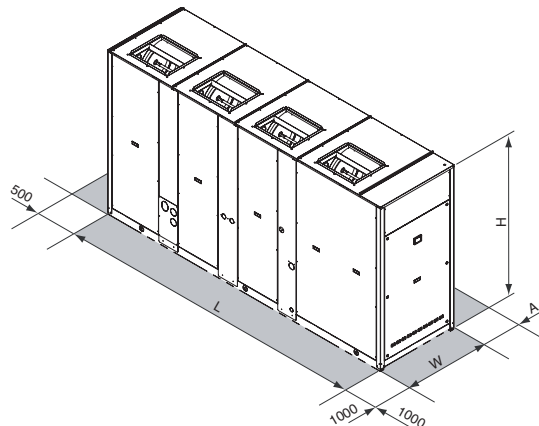

	40.2	50.2	60.2	70.2	80.2	90.2	100.2	115.2	130.2	145.2	160.2	180.2	200.2	
L			2501					3343		3343		4097		mm
W			954					1104		1104		1104		mm
H			1930					1793		2193		2193		mm
A			1600							2000				mm
Operating maximum weight	1078	1082	1102	1143	1168	1684	1765	1825	2000	2042	2094	2423	2467	kg



# > CGC HE

## CONDENSING UNITS FOR INDOOR INSTALLATION



**ADAPTIVE  
FUNCTION**



### Available range

#### Unit type

- SR** Condensing unit  
**SP** Heat pump condensing unit  
(reversible on the refrigerant side)

#### Version

- VB** Base version  
**VD** Desuperheater version  
**VR** Total recovery version

#### Acoustic setting up

- AB** Base setting up  
**AS** Low noise setting up

#### Source temperature level

- M** Medium temperature level  
**A** High temperature level

### Unit description

This series of condensing units satisfies the cooling and heating requirements of residential plants of medium size.

All the units are suitable for outdoor installation and can be connected to a remote heat exchanger properly designed in order to transfer to the plant all the cooling (and heating for reversible units) power generated.

The refrigerant circuit, contained in a compartment protected from the air flow to simplify the maintenance operations, is equipped with scroll compressors mounted on damper supports, thermostatic expansion

valve (only for SP), reverse cycle valve, double inlet centrifugal fans with forward curved blades, finned coil made of copper pipes and aluminium louvered fins with subcooling section. The circuit is protected by a safety gas valve, high and low pressure switches.

All the units can be equipped with variable speed fans control that allows the units to operate with low outdoor temperatures in cooling and high outdoor temperature in heating and permits to reduce noise emissions in such operating conditions.

The low noise acoustic setting up (AS) is obtained, starting from the base setting up (AB), mounting sound jackets on the compressors and the technical compartment is clad with soundproofing material of suitable thickness.

All the units are supplied with a management and control electrical panel containing general switch, phase presence and correct sequence controller, microprocessor controller with display and all the other electrical components with IP54 minimum protection degree.

All the units are accurately built and individually tested in the factory.

All the units are supplied with refrigerant charge inside.

Only electric and refrigerant connections (between condensing unit and remote heat exchanger) are required for installation.

### Options

#### Compressor starting

- standard (contactors)
- soft starter

#### Fans control

- on-off control
- modulating control INVERTER (condensation / evaporation control)

#### Compressor power factor correction

#### Electrical load protection

- fuses
- thermal magnetic circuit breakers

#### Coil condensate tray

(standard for SP)

### Accessories

Rubber vibration dampers

Spring vibration dampers

Coil protection grilles

Remote control

Modbus serial interface on RS485

Programmer clock

Phase sequence and voltage controller

Low temperature kit (standard for SP)

High and low pressure gauges

High temperature thermostat

Coil shut off valves

Outdoor air sensor

Remote plate heat exchanger

Liquid line

**NOMINAL performances**

SR	Base setting up (AB)	40.2	50.2	60.2	70.2	80.2	90.2	100.2	115.2	130.2	145.2	160.2	180.2	
A35E5	Cooling capacity	51,2	60,7	68,5	76,7	90,5	103,0	116	131	145	166	188	214	kW
	Power input	14,8	17,0	19,7	21,8	27,0	30,9	34,3	38,3	42,3	49,5	54,8	63,9	kW
	EER	3,46	3,57	3,48	3,52	3,35	3,33	3,38	3,42	3,43	3,35	3,43	3,35	W/W
SR	Low noise setting up (AS)	40.2	50.2	60.2	70.2	80.2	90.2	100.2	115.2	130.2	145.2	160.2	180.2	
A35E5	Cooling capacity	51,2	60,7	68,5	76,7	90,5	103,0	116	131	145	166	188	214	kW
	Power input	14,8	17,0	19,7	21,8	27,0	30,9	34,3	38,3	42,3	49,5	54,8	63,9	kW
	EER	3,46	3,57	3,48	3,52	3,35	3,33	3,38	3,42	3,43	3,35	3,43	3,35	W/W
SP	Base setting up (AB)	40.2	50.2	60.2	70.2	80.2	90.2	100.2	115.2	130.2	145.2	160.2	180.2	
A35E5	Cooling capacity	49,1	58,2	65,9	73,7	88,2	100,2	112	125	139	160	180	207	kW
	Power input	14,5	16,9	19,3	21,5	26,5	30,0	33,6	37,5	41,4	48,1	53,8	62,2	kW
	EER	3,39	3,44	3,41	3,43	3,33	3,34	3,33	3,33	3,36	3,33	3,35	3,33	W/W
A7C50	Heating capacity	49,2	58,0	65,6	73,6	87,9	99,8	112	125	140	160	180	206	kW
	Power input	15,3	17,8	20,4	22,9	27,4	31,0	34,8	39,0	43,5	50,0	55,9	64,2	kW
	COP	3,22	3,26	3,22	3,21	3,21	3,22	3,22	3,21	3,22	3,20	3,22	3,21	W/W
A7C45	Heating capacity	54,1	63,8	72,2	81,0	96,7	110	123	138	154	176	198	227	kW
	Power input	13,5	15,7	18,0	20,2	24,1	27,3	30,6	34,3	38,3	44,0	49,2	56,5	kW
	COP	4,01	4,06	4,01	4,01	4,01	4,03	4,02	4,02	4,02	4,00	4,02	4,02	W/W
SP	Low noise setting up (AS)	40.2	50.2	60.2	70.2	80.2	90.2	100.2	115.2	130.2	145.2	160.2	180.2	
A35E5	Cooling capacity	49,1	58,2	65,9	73,7	88,2	100,2	112	125	139	160	180	207	kW
	Power input	14,5	16,9	19,3	21,5	26,5	30,0	33,6	37,5	41,4	48,1	53,8	62,2	kW
	EER	3,39	3,44	3,41	3,43	3,33	3,34	3,33	3,33	3,36	3,33	3,35	3,33	W/W
A7C50	Heating capacity	49,2	58,0	65,6	73,6	87,9	99,8	112	125	140	160	180	206	kW
	Power input	15,3	17,8	20,4	22,9	27,4	31,0	34,8	39,0	43,5	50,0	55,9	64,2	kW
	COP	3,22	3,26	3,22	3,21	3,21	3,22	3,22	3,21	3,22	3,20	3,22	3,21	W/W
A7C45	Heating capacity	54,1	63,8	72,2	81,0	96,7	110	123	138	154	176	198	227	kW
	Power input	13,5	15,7	18,0	20,2	24,1	27,3	30,6	34,3	38,3	44,0	49,2	56,5	kW
	COP	4,01	4,06	4,01	4,01	4,01	4,03	4,02	4,02	4,02	4,00	4,02	4,02	W/W

The values are referred to units without options and accessories.  
**EER** (Energy Efficiency Ratio) = ratio of the total cooling capacity to the effective power input of the unit  
**COP** (Coefficient Of Performance) = ratio of the total heating capacity to the effective power input of the unit

**A35E5** = source : air in 35°C d.b. / plant : evaporation temperature (dew point) 5°C - superheating 5°C  
**A7C50** = source : air in 7°C d.b. 6°C w.b. / plant : condensation temperature (dew point) 50°C - subcooling 5°C  
**A7C45** = source : air in 7°C d.b. 6°C w.b. / plant : condensation temperature (dew point) 45°C - subcooling 5°C

### Acoustic performances

Base setting up (AB)	40.2	50.2	60.2	70.2	80.2	90.2	100.2	115.2	130.2	145.2	160.2	180.2	
Sound power level	88	88	89	89	91	91	91	96	96	97	97	98	dB(A)
Sound pressure level at 1 meter	70	70	71	71	73	73	73	78	78	79	79	80	dB(A)
Sound pressure level at 5 meters	61	61	62	62	65	65	65	69	69	70	70	71	dB(A)
Sound pressure level at 10 meters	56	56	57	57	59	59	59	64	64	65	65	66	dB(A)
Low noise setting up (AS)	40.2	50.2	60.2	70.2	80.2	90.2	100.2	115.2	130.2	145.2	160.2	180.2	
Sound power level	85	85	86	86	88	88	88	93	93	94	94	95	dB(A)
Sound pressure level at 1 meter	67	67	68	68	70	70	70	75	75	76	76	77	dB(A)
Sound pressure level at 5 meters	58	58	59	59	62	62	62	66	66	67	67	68	dB(A)
Sound pressure level at 10 meters	53	53	54	54	56	56	56	61	61	62	62	63	dB(A)

The values are referred to units without options and accessories.

The acoustic performances are referred to units operating in cooling mode at nominal conditions A35E5.

Unit placed in free field on reflecting surface (directional factor equal to 2).

The sound power level is measured according to ISO 9614 standard.

The sound pressure level is calculated according to ISO 3744 and is referred to a distance of 1/5/10 metres from the external surface of the unit.

### Technical data

Unit	40.2	50.2	60.2	70.2	80.2	90.2	100.2	115.2	130.2	145.2	160.2	180.2	
Power supply	400 - 3 - 50												V-ph-Hz
Compressor type	scroll												-
N° compressors / N° refrigerant circuits	2 / 1												n°
Source side heat exchanger type	finned coil												-
Fans type	centrifugal												-
N° fans	1			2			3			4			n°
Liquid line connection	7/8"			1 1/8"						1 3/8"			-
Gas line connection	1 5/8"			2 1/8"									-

### Electrical data

Standard unit	40.2	50.2	60.2	70.2	80.2	90.2	100.2	115.2	130.2	145.2	160.2	180.2	
<b>FLA</b> - Full load current at maximum tolerated conditions	43,2	48,8	56,7	62,1	74,9	80,5	95,0	109	117	145	169	188	A
<b>FLI</b> - Full load power input at maximum tolerated conditions	25,2	28,0	33,0	35,6	41,9	47,3	58,3	67,3	72,8	88,7	103	113	kW
<b>MIC</b> - Maximum instantaneous current of the unit	137	147	152	177	218	269	264	278	278	370	394	384	A
<b>MIC SS</b> - Maximum instantaneous current of the unit with soft starter options	92,4	99,4	105	121	148	179	180	194	194	222	279	277	A

### Operative range

Temperature	Unit type	Cooling		Heating		
		min	max	min	max	
Outdoor air inlet temperature	SR, SP	-10*	48	-15	40*	°C
Evaporating temperature (dew point)	SR, SP	1	20	-	-	°C
Condensing temperature (dew point)	SP	-	-	35	60	°C
Water outlet temperature (VD)	SR, SP	30	70	30	70	(°C)
Water outlet temperature (VR)	SR	30	55	-	-	(°C)

\* with fans modulating control option (condensation / evaporation control)

### Aeraulic performance

Unit	40.2	50.2	60.2	70.2	80.2	90.2	100.2	115.2	130.2	145.2	160.2	180.2	
Available static head	150	150	150	150	150	150	150	150	150	150	150	150	Pa

## VD and VR versions

These units allow to recover the heating power, otherwise wasted on air, through an additional heat exchanger.

The **Desuperheater Version (VD)** allow the hot water production at temperatures between 30 and 70°C through the partial heat recovery of the condensation heat.

The **Total Recovery Version (VR)** allows the cold water production and, at the same time, the hot water production at temperatures between 30 and 55°C through the total recovery of the condensation heat.

### Desupeheater Version (VD) - NOMINAL performances

SR	Base setting up (AB)	40.2	50.2	60.2	70.2	80.2	90.2	100.2	115.2	130.2	145.2	160.2	180.2	
A35E5 - W45	Cooling capacity	53,2	63,1	71,2	79,7	94,1	107	120	136	151	173	195	222	kW
	Total power input	14,4	16,5	19,1	21,1	26,2	30,0	33,2	37,2	41,1	48,0	53,2	62,0	kW
	<b>EER</b>	<b>3,69</b>	<b>3,82</b>	<b>3,73</b>	<b>3,78</b>	<b>3,59</b>	<b>3,57</b>	<b>3,61</b>	<b>3,66</b>	<b>3,67</b>	<b>3,60</b>	<b>3,67</b>	<b>3,58</b>	<b>W/W</b>
	Heating recovery capacity	15,4	18,3	20,7	23,1	27,3	31,1	34,9	39,4	43,6	50,2	56,7	64,5	kW
	Water flow rate recovery	0,74	0,87	0,99	1,10	1,30	1,48	1,67	1,88	2,09	2,40	2,71	3,08	l/s
	Water pressure drop recovery	8	12	15	18	25	20	24	14	18	24	29	24	kPa

SP	Base setting up (AB)	40.2	50.2	60.2	70.2	80.2	90.2	100.2	115.2	130.2	145.2	160.2	180.2	
A35E5 - W45	Cooling capacity	51,1	60,5	68,5	76,6	91,8	104	117	130	145	166	188	216	kW
	Total power input	14,1	16,4	18,7	20,8	25,7	29,1	32,6	36,4	40,2	46,6	52,2	60,3	kW
	<b>EER</b>	<b>3,62</b>	<b>3,69</b>	<b>3,66</b>	<b>3,68</b>	<b>3,57</b>	<b>3,57</b>	<b>3,59</b>	<b>3,57</b>	<b>3,61</b>	<b>3,56</b>	<b>3,60</b>	<b>3,58</b>	<b>W/W</b>
	Heating recovery capacity	14,8	17,6	19,9	22,2	26,6	30,2	33,9	37,8	42,0	48,2	54,4	62,5	kW
	Water flow rate recovery	0,71	0,84	0,95	1,06	1,27	1,44	1,62	1,81	2,01	2,30	2,60	2,99	l/s
	Water pressure drop recovery	7	11	14	17	24	19	22	13	17	22	27	23	kPa

### Total Recovery Version (VR) - NOMINAL performances

SR	Base setting up (AB)	40.2	50.2	60.2	70.2	80.2	90.2	100.2	115.2	130.2	145.2	160.2	180.2	
A35E5 - W45	Cooling capacity	53,2	63,1	71,2	79,7	94,1	107	120	136	151	173	195	222	kW
	Total power input	14,2	16,4	18,9	20,9	25,9	29,7	32,9	36,8	40,6	47,5	52,6	61,4	kW
	<b>EER</b>	<b>3,75</b>	<b>3,85</b>	<b>3,77</b>	<b>3,81</b>	<b>3,63</b>	<b>3,60</b>	<b>3,65</b>	<b>3,70</b>	<b>3,72</b>	<b>3,64</b>	<b>3,71</b>	<b>3,62</b>	<b>W/W</b>
	Heating recovery capacity	66,8	78,7	89,1	99,6	119	135	151	171	189	218	245	281	kW
	Water flow rate recovery	3,19	3,76	4,26	4,76	5,68	6,47	7,23	8,16	9,03	10,42	11,7	13,4	l/s
	Water pressure drop recovery	43	60	54	53	64	61	65	63	66	67	71	76	kPa

Data declared according to **EN 14511**. The values are referred to units without options and accessories.

**EER** (Energy Efficiency Ratio) = ratio of the total cooling capacity to the effective power input of the unit

**HRE** (Heat Recovery Efficiency) = ratio of the total capacity of the system (heating plus cooling capacity) to the effective power input

**A35W7 - W45** = source : air in 35°C d.b. / plant : water in 12°C out 7°C / Recovery : water in 40°C out 45°C

## CONTROL SYSTEM

The units are equipped with a controller designed to ensure energy saving and unit efficiency. Available functions :

- Adaptive function
- Dynamic defrost
- Sound management
- Climatic control in heating and in cooling mode
- Economy function
- Demand limit
- Integrative heating
- Remote stand by
- Remote cooling-heating



## DIMENSIONS - MINIMUM OPERATING AREA - WEIGHT

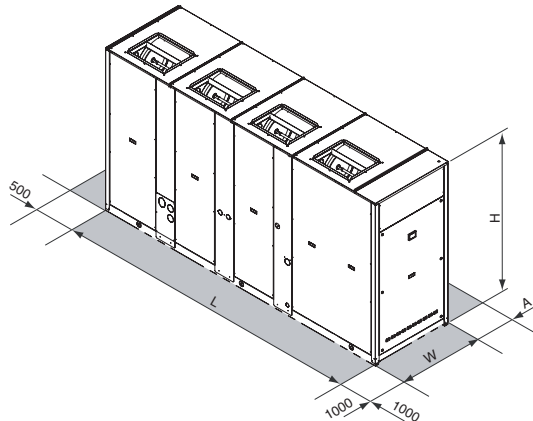

	40.2	50.2	60.2	70.2	80.2	90.2	100.2	115.2	130.2	145.2	160.2	180.2		
L		2501				3343			3343		4097			mm
W		954				1104			1104		1104			mm
H		1930				1793			2193		2193			mm
A		1600							2000					mm
Operating maximum weight	1121	1125	1146	1189	1670	1751	1836	2051	2080	2124	2478	2520	kg	



# > EGW

## CONDENSERLESS UNITS FOR INDOOR INSTALLATION



Unit with closing panels

### Available range

#### Unit type

- IR Condenserless unit
- BR Condenserless unit Brine

#### Version

- VB Base version

#### Acoustic setting up

- AB Base setting up
- AS Low noise setting up
- AX eXtra low noise setting up

### Unit description

This series of condenserless unit satisfies the cooling and heating requirements of commercial and industrial plants of medium size.

All the units are suitable for indoor installation and can be applied to fan coil plants and radiant floor plants.

The refrigerant circuit is equipped with 2 scroll compressors, mounted on rubber vibration-damper supports, plant side heat exchanger brazed plate-type in stainless steel (AISI 316), complete with thermal insulation shell and differential pressure switch, thermostatic expansion valve or electronic expansion valve (as option), dehydrator filter, solenoid valve to shut-

off the liquid line, shut-off ball valves on the discharge and liquid lines, refrigerant circuit protected by refrigerant safety valve, low and high pressure switches, electrical panel for power and control complete with main breaker power supply with door lock function microprocessor controller with keyboard-display, and phase sequence controller (standard). The units can be chosen in Basic setting up (AB) (unit without closing panels), Low noise setting up (AS), featuring closing panels coated with acoustic material, Extra Low noise setting up (AX) featuring closing panels coated with superior acoustic material and soundproofing jackets on the compressors.

The units are suitable to be combined with remote condensers cooled by air (coil and fans) or remote condensers cooled by water (plates or shell and tube heat exchanger). The electronic controller can manage the numerous ways used on the market for the head pressure control for condensation by air and for condensation by water. A wide range of options and accessories completes the commercial offer. All the units are carefully built in compliance with the current regulations and individually tested.

The units are supplied with charge of NITROGEN in order to avoid the entrance of air inside the refrigerant circuit.

### Options

#### Expansion valve

- thermostatic
- electronic

Suitable for outdoor installation

### Accessories

- Rubber vibration dampers
- Remote controller
- Serial Interface Modbus-RS 485
- Programmer clock
- Phase sequence and voltage controller
- Low temperature kit
- High and low pressure gauges
- High temperature thermostat
- Compressors shut-off valves
- Outdoor air sensor
- Water flow switch
- Victaulic hydraulic fittings
- Victaulic bends
- Victaulic water shut-off valves
- Victaulic water filter
- 2-way valve for condensing control
- 3-way valve for condensing control
- Compressors start-up with soft starter
- Compressors power factor correction
- Electrical load protection with thermal magnetic circuit breakers
- Remote condenser cooled by air

### CONTROL SYSTEM

The units are equipped with a controller designed to ensure energy saving and unit efficiency. Available functions :

- Adaptive function
- Climatic control in heating and in cooling mode
- Economy function
- Demand limit
- Condensation control
- Remote stand by



**NET NOMINAL performances - Standard plants**

IR	70.2	80.2	90.2	105.2	120.2	135.2	150.2	170.2	190.2	215.2	240.2		
<b>C45W7</b>	Cooling capacity	64,8	72,1	85,5	97,2	109	123	138	158	178	201	222	kW
	Power input	17,8	19,5	23,5	26,8	30,2	34,2	38,3	43,6	48,9	55,3	61,6	kW
	<b>EER</b>	<b>3,63</b>	<b>3,69</b>	<b>3,64</b>	<b>3,63</b>	<b>3,60</b>	<b>3,59</b>	<b>3,59</b>	<b>3,61</b>	<b>3,63</b>	<b>3,63</b>	<b>3,60</b>	<b>W/W</b>
	Water flow rate source side	3,12	3,46	4,11	4,67	5,24	5,90	6,62	7,58	8,54	9,66	10,7	l/s
	Pressure drops source side	41	32	35	36	38	36	39	40	42	42	42	kPa
<b>C50W7</b>	Cooling capacity	60,7	67,7	80,6	91,5	102,5	115,4	129,3	148,2	167,0	188,9	208,7	kW
	Power input	19,7	21,7	26,2	29,8	33,5	37,8	42,2	48,1	53,9	61,0	68,0	kW
	<b>EER</b>	<b>3,07</b>	<b>3,12</b>	<b>3,08</b>	<b>3,07</b>	<b>3,06</b>	<b>3,05</b>	<b>3,06</b>	<b>3,08</b>	<b>3,10</b>	<b>3,10</b>	<b>3,07</b>	<b>W/W</b>
	Water flow rate source side	2,91	3,25	3,87	4,40	4,92	5,54	6,21	7,12	8,03	9,08	10,0	l/s
	Pressure drops source side	36	28	31	31	34	32	35	35	37	37	38	kPa

Data declared according to **EN 14511**. The values are referred to units without options and accessories.

**EER** (Energy Efficiency Ratio) = ratio of the total cooling capacity to the effective power input of the unit

**C50W7** = condensing temperature (dew point) = 50 °C - subcooling = 5°C - plant : water in 12°C out 7°C

**C45W7** = condensing temperature (dew point) = 45 °C - subcooling = 5°C - plant : water in 12°C out 7°C

**Acoustic performances**

<b>Base setting up (AB)</b>	70.2	80.2	90.2	105.2	120.2	135.2	150.2	170.2	190.2	215.2	240.2	
Sound power level	75	76	77	77	77	78	78	79	79	80	80	dB(A)
Sound pressure level at 1 meter	59	60	61	61	61	62	62	63	63	64	64	dB(A)
Sound pressure level at 5 meters	49	50	51	51	51	52	52	53	53	54	54	dB(A)
Sound pressure level at 10 meters	44	45	46	46	46	47	47	48	48	49	49	dB(A)
<b>Low noise setting up (AS)</b>	70.2	80.2	90.2	105.2	120.2	135.2	150.2	170.2	190.2	215.2	240.2	
Sound power level	71	72	73	73	73	74	74	75	75	76	76	dB(A)
Sound pressure level at 1 meter	55	56	57	57	57	58	58	59	59	60	60	dB(A)
Sound pressure level at 5 meters	45	46	47	47	47	48	48	49	49	50	50	dB(A)
Sound pressure level at 10 meters	40	41	42	42	42	43	43	44	44	45	45	dB(A)
<b>eXtra low noise setting up (AX)</b>	70.2	80.2	90.2	105.2	120.2	135.2	150.2	170.2	190.2	215.2	240.2	
Sound power level	67	68	69	69	69	70	70	71	71	72	72	dB(A)
Sound pressure level at 1 meter	51	52	53	53	53	54	54	55	55	56	56	dB(A)
Sound pressure level at 5 meters	41	42	43	43	43	44	44	45	45	46	46	dB(A)
Sound pressure level at 10 meters	36	37	38	38	38	39	39	40	40	41	41	dB(A)

The acoustic performances are referred to units operating in cooling mode at nominal conditions C50W7.

Unit placed in free field on reflecting surface (directional factor equal to 2).

The sound power level is measured according to ISO 9614 standard.

The sound pressure level is calculated according to ISO 3744 and is referred to a distance of 1/5/10 metres from the external surface of the unit.

**Technical data**

Unit	70.2	80.2	90.2	105.2	120.2	135.2	150.2	170.2	190.2	215.2	240.2	
Power supply	400 - 3 - 50											V-ph-Hz
<b>Max working pressure (HP-PS)</b>	43											bar
Compressor type	scroll											-
N° compressors / N° refrigerant circuits	2 / 1											n°
Plant side heat exchanger type	stainless steel brazed plates											-
IN/OUT Plant side hydraulic fittings	2" 1/2 VICTAULIC											"
Refrigerant liquid line fitting	28 ODS					35 ODS						mm
Refrigerant gas line fitting	42 ODS											mm

**Electrical data**

Standard unit	70.2	80.2	90.2	105.2	120.2	135.2	150.2	170.2	190.2	215.2	240.2	
<b>FLA</b> - Full load current at maximum tolerated conditions	45	51	62	68	74	82	90	105	120	142	164	A
<b>FLI</b> - Full load power input at maximum tolerated conditions	26	29	34	40	45	50	55	63	72	83	93	kW
<b>MIC</b> - Maximum instantaneous current of the unit	141	166	204	256	262	309	317	355	370	454	476	A

**Operating range**

Temperature	Unit type	Cooling	
		min	max
Condensing temp (dew point)	IR, BR	30	60
Water outlet temperature plant side	IR	5	20
Water outlet temperature plant side	BR	-10	5

**DIMENSIONS - MINIMUM OPERATING AREA - WEIGHT**

(reference drawing: unit with closing panel)

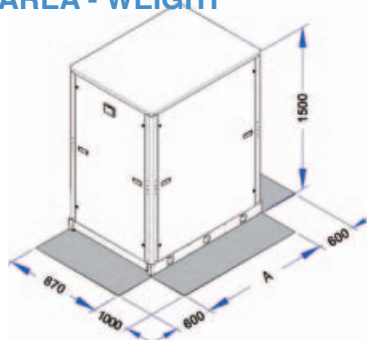

Models	70.2	80.2	90.2	105.2	120.2	135.2	150.2	170.2	190.2	215.2	240.2		
A	880											1175	mm
Operating maximum weight	368	378	385	501	581	607	632	669	694	724	747	kg	

## Remote condenser

This series of remote axial condensers uses copper pipes with special internal riffling and a high efficiency fin.

The fin has been specially designed to guarantee a high thermal exchange coefficient with low air pressure drops. By combining both special tubes and fins the following features can be achieved:

- Maximum capacity related to the heat exchanger's dimensions.
- Minimum refrigerant charge.
- The most strict environment standards for sound pollution can be met.

This new series of axial condensers is equipped with fans with scythe-shaped blades to reduce the sound emission. From the noise level point of view, all models can be supplied as basic version (AB), low noise version (AS) or extra low noise version (AX). To guarantee solidity, strength and the maximum resistance to atmospheric agents the bearing and the casing are manufactured with galvanized steel and oven painted with a polyurethane resin (the standard colour is RAL 7035).

## Options

- Special fins (Copper, Painted Aluminium, ecc.).
- Special motors
- Vertical / Horizontal air flow
- EC fans



## Accessories

All models can be equipped with several accessories as:

- Rubber Vibrations Dampers
  - Modulating control of the fans with cut of phase regulator
  - Modulating control of the fans with inverter regulator
  - Electrical Wiring Box, allows a fast and safe electrical installation of the unit since all wires and thermal protections of the fans are connected inside a waterproof box (IP54) to a terminal block where the installer connect the electrical supply and the fans thermal switches signal.
  - Electrical Panel CE this accessory (like the electrical wiring box) allows a fast and safe electrical installation and moreover simplify the standard and non standard maintenance of the unit.
- The accessory is in fact composed by main electrical switch, fuses and contactors of the fans, transformer to supply an alarm auxiliary relè, terminal block for remote ON-OFF (i.e. sent by the condenserless unit).

## Technical data

Unit	70.2	80.2	90.2	105.2	120.2	135.2	150.2	170.2	190.2	215.2	240.2	
Power supply	400 - 3 - 50											V-ph-Hz
Fan type	axial											-
Max working pressure (PS)	45											bar
Coil exchanger type	Aluminum fins and copper tubes											-

## Acoustic performances

Base setting up (AB)	70.2	80.2	90.2	105.2	120.2	135.2	150.2	170.2	190.2	215.2	240.2	
Sound power level	80	80	82	83	83	83	83	85	85	85	85	dB(A)
Sound pressure level at 1 meter	63	63	65	66	66	66	66	68	68	68	68	dB(A)
Sound pressure level at 5 meters	53	53	55	56	56	56	56	58	58	58	58	dB(A)
Sound pressure level at 10 meters	48	48	50	51	51	51	51	53	53	53	53	dB(A)
Low noise setting up (AS)	70.2	80.2	90.2	105.2	120.2	135.2	150.2	170.2	190.2	215.2	240.2	
Sound power level	75	75	76	76	76	76	76	76	77	77	77	dB(A)
Sound pressure level at 1 meter	58	58	57	57	57	59	59	59	60	60	60	dB(A)
Sound pressure level at 5 meters	48	48	47	47	47	49	49	49	50	50	50	dB(A)
Sound pressure level at 10 meters	43	43	42	42	42	44	44	44	45	45	45	dB(A)
eXtra low noise setting up (AX)	70.2	80.2	90.2	105.2	120.2	135.2	150.2	170.2	190.2	215.2	240.2	
Sound power level	68	68	68	68	70	70	70	71	71	73	73	dB(A)
Sound pressure level at 1 meter	51	51	51	51	53	53	53	54	54	56	56	dB(A)
Sound pressure level at 5 meters	41	41	41	41	43	43	43	44	44	46	46	dB(A)
Sound pressure level at 10 meters	36	36	36	36	38	38	38	39	39	41	41	dB(A)

<b>Base setting up (AB)</b>		<b>70.2</b>	<b>80.2</b>	<b>90.2</b>	<b>105.2</b>	<b>120.2</b>	<b>135.2</b>	<b>150.2</b>	<b>170.2</b>	<b>190.2</b>	<b>215.2</b>	<b>240.2</b>	
Refrigerant connections	Gas	1x42	1x42	1x42	1x42	1x42	1x42	1x42	1x42	1x54	1x54	1x54	n° x Ø
	Liquid	1x35	1x35	1x35	1x28	1x35	1x35	1x35	1x35	1x42	1x42	1x42	n° x Ø
Fan specification	Fan	2	2	3	2	2	2	2	3	3	3	3	n°
	Diameter	630	630	630	800	800	800	800	800	800	800	800	mm
	Air flow rate	5556	5556	8917	11778	10889	10889	10222	17667	16333	15333	15333	l/s
	Power input	1,46	1,46	2,19	4,00	4,00	4,00	4,00	6,00	6,00	6,00	6,00	kW
Standard configuration	Length [L]	2630	2630	3770	3230	3230	3230	3230	4580	4580	4580	4580	mm
	Height [A]	1230	1230	1230	1370	1370	1370	1370	1370	1370	1370	1370	mm
	Depth [P]	600	600	600	800	800	800	800	800	800	800	800	mm
Configuration with support brackets	Length [L]	2630	2630	3770	3230	3230	3230	3230	4580	4580	4580	4580	mm
	Height [A]	990	990	990	1565	1565	1565	1565	1565	1565	1565	1565	mm
	Depth [P]	1230	1230	1230	1370	1370	1370	1370	1370	1370	1370	1370	mm
Weight		166	166	221	279	302	302	324	413	447	481	481	kg

<b>Low noise setting up (AS)</b>		<b>70.2</b>	<b>80.2</b>	<b>90.2</b>	<b>105.2</b>	<b>120.2</b>	<b>135.2</b>	<b>150.2</b>	<b>170.2</b>	<b>190.2</b>	<b>215.2</b>	<b>240.2</b>	
Refrigerant connections	Gas	1x42	1x42	1x42	1x42	1x42	1x42	1x54	1x54	2x42	2x42	2x42	n° x Ø
	Liquid	1x35	1x35	1x28	1x35	1x35	1x35	1x42	1x42	2x35	2x35	2x35	n° x Ø
Fan specification	Fan	3	3	2	2	2	3	3	3	4	4	4	n°
	Diameter	630	630	800	800	800	800	800	800	800	800	800	mm
	Air flow rate	6250	6250	9389	7944	7444	14083	11917	11167	15222	14111	14111	l/s
	Power input	0,99	0,99	1,96	1,96	1,96	2,94	2,94	2,94	3,92	3,92	3,92	kW
Standard configuration	Length [L]	3770	3770	3230	3230	3230	4580	4580	4580	3230	3230	3230	mm
	Height [A]	1230	1230	1370	1370	1370	1370	1370	1370	2390	2390	2390	mm
	Depth [P]	600	600	800	800	800	800	800	800	800	800	800	mm
Configuration with support brackets	Length [L]	3770	3770	3230	3230	3230	4580	4580	4580	3230	3230	3230	mm
	Height [A]	990	990	1565	1565	1565	1565	1565	1565	1565	1565	1565	mm
	Depth [P]	1230	1230	1370	1370	1370	1370	1370	1370	2390	2390	2390	mm
Weight		221	221	279	302	324	413	447	481	502	543	543	kg

<b>eXtra low noise setting up (AX)</b>		<b>70.2</b>	<b>80.2</b>	<b>90.2</b>	<b>105.2</b>	<b>120.2</b>	<b>135.2</b>	<b>150.2</b>	<b>170.2</b>	<b>190.2</b>	<b>215.2</b>	<b>240.2</b>	
Refrigerant connections	Gas	1x42	1x42	1x42	1x42	1x42	1x54	1x54	2x42	2x42	2x42	2x42	n° x Ø
	Liquid	1x28	1x28	1x35	1x35	1x35	1x42	1x42	2x35	2x35	2x35	2x35	n° x Ø
Fan specification	Fan	2	2	2	2	3	3	3	4	4	4	4	n°
	Diameter	800	800	800	800	800	800	800	800	800	800	800	mm
	Air flow rate	6778	6778	6111	5611	10167	9167	8417	11556	10667	19333	19333	l/s
	Power input	1,18	1,18	1,18	1,18	1,77	1,77	1,77	2,36	2,36	2,36	2,36	kW
Standard configuration	Length [L]	3230	3230	3230	3230	4580	4580	4580	3230	3230	4580	4580	mm
	Height [A]	1370	1370	1370	1370	1370	1370	1370	2390	2390	2390	2390	mm
	Depth [P]	800	800	800	800	800	800	800	800	800	800	800	mm
Configuration with support brackets	Length [L]	3230	3230	3230	3230	4580	4580	4580	3230	3230	4580	4580	mm
	Height [A]	1565	1565	1565	1565	1565	1565	1565	1565	1565	1565	1565	mm
	Depth [P]	1370	1370	1370	1370	1370	1370	1370	2390	2390	2390	2390	mm
Weight		279	279	302	324	413	447	481	502	543	680	680	kg

**Standard configuration (horizontal air flow)**

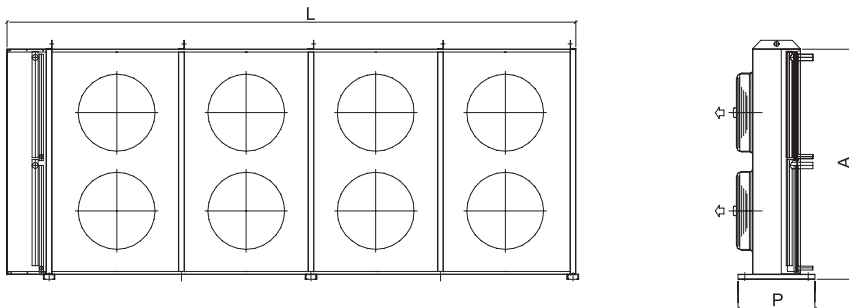

**Configuration with Support Brackets (vertical air flow)**

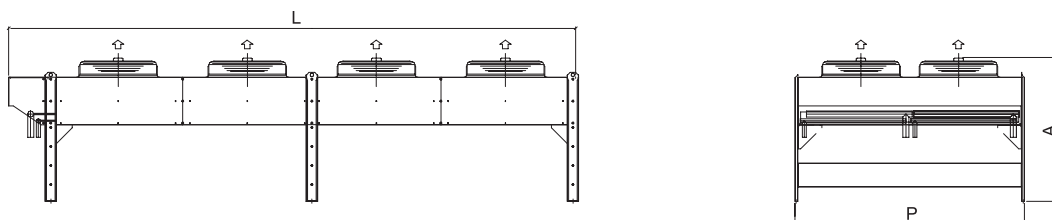



# > EVW

## CONDENSERLESS UNITS FOR INDOOR INSTALLATION



### Available range

#### Unit type

- IR Condenserless unit
- BR Condenserless unit Brine

#### Version

- VB Base version
- VD Desuperheaters version

#### Acoustic setting up

- AB Base setting up
- AS Low noise setting up

### Unit description

This range of condenserless units are designed to meet the climate control and air conditioning needs of large capacity systems in the industrial and commercial sectors. All the units are suitable for indoor installation and can be applied to fan coil plants.

Suitable for indoor installation, as standard the units are equipped with 1 or 2 TWIN-SCREW semihermetic compressors mounted on rubber vibration dampers able to modulate the capacity from minimum 25 (not for all configurations) to 100%, plant side exchanger shell and tube type complete with Victaulic water connections, fitted inside a shell of thermal insulation material to prevent condensation and heat exchange with the outside, optimised for R134a with high efficiency grooved tubes, protected by means of a water differential pressure

switch, 1 or 2 independent refrigerant circuits, complete with electronic expansion valve which optimises unit efficiency at full and partial loads and enables maximum seasonal efficiency, maximum and minimum pressure switch, PED safety valves, dehydrator filter, liquid/moisture indicator, compressor discharge and liquid shut-off valves, high and low pressure transducers, electrical panel with minimum protection IP54 containing the electrical equipment and all the components to control and command the unit complete with main supply breaker with door lock function, phase sequence control device, microprocessor controller with display (4 lines of 20 characters).

The units can be selected as Base setting up (AB) or as Low noise setting up (AS) that provides that compressors are positioned inside a soundproofed cabin, made with profiles and panels insulated with acoustic material.

The units are suitable to be combined with remote condensers cooled by air (coil and fans) or remote condensers cooled by water (plate or shell and tube heat exchanger). The electronic controller can manage the numerous ways used on the market for the head pressure control for condensation by air and for condensation by water. A wide range of options and accessories completes the commercial offer. All the units are carefully built in compliance with the current regulations and individually tested.

The units are supplied with charge of NITROGEN in order to avoid the entrance of air inside the refrigerant circuit.

### Options

#### Compressor starting

- standard (contactors)
- soft starter

#### Compressors power factor correction

#### Electrical load protection

- standard (fuses)
- thermal magnetic circuit breakers

#### Evaporator flow switch (mounted)

#### Evaporator insulation higher thickness

#### Evaporator electrical heater for winter antifreeze

#### High and low pressure gauges

#### Compressor suction shut-off valve

### Accessories

#### Rubber vibration dampers

External Water Storage Tank and Pumping Module complete with insulated carbon steel tank, single or twin pump and all hydronic components.

#### Antifreeze electrical heaters for Storage tank

#### Remote controller

#### Serial Interface Modbus on RS 485

#### Programmer clock

#### Phase sequence and voltage controller

#### Water flow switch

#### Remote condenser cooled by air

### CONTROL SYSTEM

The units are equipped with a controller designed to ensure energy saving and unit efficiency.

Available functions :



**NET NOMINAL performances - Standard plants**

IR		280.1	320.1	360.1	420.1	480.1	540.1	600.1	710.2	820.2	950.2	1100.2	1200.2	
C45W7	Cooling capacity	263	291	330	382	444	502	551	661	764	888	1001	1103	kW
	Power input	67,1	73,7	84,2	97	113	128	142	170	195	227	259	280	kW
	<b>EER</b>	<b>3,92</b>	<b>3,95</b>	<b>3,92</b>	<b>3,95</b>	<b>3,93</b>	<b>3,92</b>	<b>3,89</b>	<b>3,88</b>	<b>3,93</b>	<b>3,92</b>	<b>3,87</b>	<b>3,93</b>	<b>W/W</b>
	Water flow rate source side	12,7	14,0	15,9	18,3	21,4	24,1	26,5	31,8	36,7	42,8	48,3	53,0	l/s
	Pressure drops source side	41	32	40	38	48	38	47	47	40	52	53	41	kPa
C50W7	Cooling capacity	248	275	312	359	420	472	520	623	719	840	943	1042	kW
	Power input	73,4	80,2	91,8	105	124	139	154	185	211	249	281	307	kW
	<b>EER</b>	<b>3,37</b>	<b>3,42</b>	<b>3,40</b>	<b>3,42</b>	<b>3,38</b>	<b>3,39</b>	<b>3,38</b>	<b>3,36</b>	<b>3,41</b>	<b>3,37</b>	<b>3,36</b>	<b>3,40</b>	<b>W/W</b>
	Water flow rate source side	11,9	13,2	15,0	17,2	20,2	22,7	25,0	30,0	34,5	40,4	45,4	50,1	l/s
	Pressure drops source side	36	28	36	34	43	34	42	41	35	47	47	36	kPa

Data declared according to EN 14511. The values are referred to units without options and accessories.  
**EER** (Energy Efficiency Ratio) = ratio of the total cooling capacity to the effective power input of the unit  
**C50W7** = condensing temperature (dew point) = 50 °C - subcooling = 5°C - plant : water in 12°C out 7°C  
**C45W7** = condensing temperature (dew point) = 45 °C - subcooling = 5°C - plant : water in 12°C out 7°C

**Desupeheater Version (VD) - NET NOMINAL performances**

IR		280.1	320.1	360.1	420.1	480.1	540.1	600.1	710.2	820.2	950.2	1100.2	1200.2	
C45W7 - W45	Cooling capacity	274	303	343	397	461	522	573	687	794	923	1041	1147	kW
	Total power input	65	72	82	94	110	125	138	166	189	221	252	273	kW
	<b>EER</b>	<b>4,19</b>	<b>4,22</b>	<b>4,19</b>	<b>4,22</b>	<b>4,19</b>	<b>4,19</b>	<b>4,15</b>	<b>4,14</b>	<b>4,19</b>	<b>4,17</b>	<b>4,12</b>	<b>4,20</b>	<b>W/W</b>
	<b>HRE</b>	<b>5,11</b>	<b>5,15</b>	<b>5,11</b>	<b>5,14</b>	<b>5,10</b>	<b>5,11</b>	<b>5,07</b>	<b>5,06</b>	<b>5,11</b>	<b>5,09</b>	<b>5,04</b>	<b>5,12</b>	<b>W/W</b>
	Water flow rate	13,2	14,5	16,5	19,1	22,2	25,1	27,6	33,1	38,2	44,5	50,2	55,2	l/s
	Water pressure	44	34	43	41	52	41	51	50	43	57	57	44	kPa
	Heating recovery capacity	60,2	66,5	75,7	86,9	101,1	115	127	152	175	202	231	252	kW
	Water flow rate recovery	2,88	3,18	3,61	4,15	4,83	5,50	6,05	7,27	8,35	9,66	11,0	12,0	l/s
	Water pressure drop recovery	8	9	9	12	11	9	11	9	12	11	9	10	kPa
	C50W7 - W45	Cooling capacity	257	286	325	373	437	491	541	647	747	873	980	1083
Total power input		71	78	89	102	121	136	150	180	205	243	274	299	kW
<b>EER</b>		<b>3,60</b>	<b>3,66</b>	<b>3,63</b>	<b>3,65</b>	<b>3,61</b>	<b>3,62</b>	<b>3,60</b>	<b>3,59</b>	<b>3,65</b>	<b>3,59</b>	<b>3,58</b>	<b>3,63</b>	<b>W/W</b>
<b>HRE</b>		<b>4,53</b>	<b>4,59</b>	<b>4,56</b>	<b>4,58</b>	<b>4,53</b>	<b>4,55</b>	<b>4,53</b>	<b>4,52</b>	<b>4,58</b>	<b>4,51</b>	<b>4,50</b>	<b>4,56</b>	<b>W/W</b>
Water flow rate		12,4	13,7	15,6	17,9	21,0	23,6	26,0	31,2	35,9	42,0	47,2	52,1	l/s
Water pressure		39	30	39	37	47	37	46	45	38	50	51	39	kPa
Heating recovery capacity		66,3	72,8	82,9	95,1	111,9	126	139	167	190	224	252	277	kW
Water flow rate recovery		3,17	3,48	3,96	4,54	5,35	6,02	6,63	7,97	9,09	10,71	12,1	13,2	l/s
Water pressure drop recovery		9	11	11	14	13	10	13	11	14	13	10	13	kPa

Data declared according to EN 14511. The values are referred to units without options and accessories.  
**EER** (Energy Efficiency Ratio) = ratio of the total cooling capacity to the effective power input of the unit  
**HRE** (Heat Recovery Efficiency) = ratio of the total capacity of the system (heating plus cooling capacity) to the effective power input  
**C50W7-W45** = condensing temperature (dew point) = 50 °C - subcooling = 5°C - plant : water in 12°C out 7°C / Recovery : water in 40°C out 45°C  
**C45W7-W45** = condensing temperature (dew point) = 45 °C - subcooling = 5°C - plant : water in 12°C out 7°C / Recovery : water in 40°C out 45°C

**Acoustic performances**

Base setting up (AB)	280.1	320.1	360.1	420.1	480.1	540.1	600.1	710.2	820.2	950.2	1100.2	1200.2	
Sound power level	97	97	97	98	98	98	98	99	100	100	100	100	dB(A)
Sound pressure level at 1 meter	79	79	79	80	80	80	80	80	81	81	81	81	dB(A)
Sound pressure level at 5 meters	70	70	70	72	72	72	71	72	73	73	73	73	dB(A)
Sound pressure level at 10 meters	65	65	65	67	67	67	66	67	68	68	68	68	dB(A)
Low noise setting up (AS)	280.1	320.1	360.1	420.1	480.1	540.1	600.1	710.2	820.2	950.2	1100.2	1200.2	
Sound power level	92	93	92	93	93	94	94	94	95	95	96	96	dB(A)
Sound pressure level at 1 meter	74	75	74	75	75	76	76	75	76	76	77	77	dB(A)
Sound pressure level at 5 meters	65	66	65	66	66	67	67	67	68	68	69	69	dB(A)
Sound pressure level at 10 meters	60	61	60	61	61	62	62	62	63	63	64	64	dB(A)

The acoustic performances are referred to units operating in cooling mode at nominal conditions C50W7.  
 Unit placed in free field on reflecting surface (directional factor equal to 2).  
 The sound power level is measured according to ISO 9614 standard.  
 The sound pressure level is calculated according to ISO 3744 and is referred to a distance of 1/5/10 metres from the external surface of the unit.

**Technical data**

Unit	280.1	320.1	360.1	420.1	480.1	540.1	600.1	710.2	820.2	950.2	1100.2	1200.2	
Power supply	400 - 3 - 50												V-ph-Hz
Max working pressure (HP-PS)	20												bar
Compressor type	twin-screw												-
N° compressors / N° refrigerant circuits	1 / 1						2 / 2						n°
Part load	25 / 100% continuous						12.5 / 100% continuous						
Plant side heat exchanger typex	shell and tube												-
IN/OUT Plant side hydraulic fittings	DN125	DN125	DN125	DN150	DN150	DN150	DN200	DN150	DN200	DN200	DN200	DN200	-
Refrigerant liquid line fitting	1x42	1x42	1x42	1x42	1x42	1x54	1x54	2x42	2x42	2x42	2x54	2x54	n° x Ø
Refrigerant gas line fitting	1x67	1x67	1x67	1x67	1x67	1x76	1x76	2x67	2x67	2x67	2x76	2x76	n° x Ø

**Electrical data**

Standard unit	280.1	320.1	360.1	420.1	480.1	540.1	600.1	710.2	820.2	950.2	1100.2	1200.2	
<b>FLA</b> - Full load current at maximum tolerated conditions	162	181	211	232	270	309	340	422	464	540	618	680	A
<b>FLI</b> - Full load power input at maximum tolerated conditions	99	110	129	144	169	190	209	257	287	339	380	418	kW
<b>MIC</b> - Maximum instantaneous current of the unit	520	612	665	436	465	586	650	876	668	735	895	990	A

**Operating range**

Temperature	Unit type	Cooling	
		min	max
Condensing temp (dew point)	IR, BR	30	60
Water outlet temperature plant side	IR	5	15
Water outlet temperature plant side	BR	-8	5

## DIMENSIONS - MINIMUM OPERATING AREA - WEIGHT

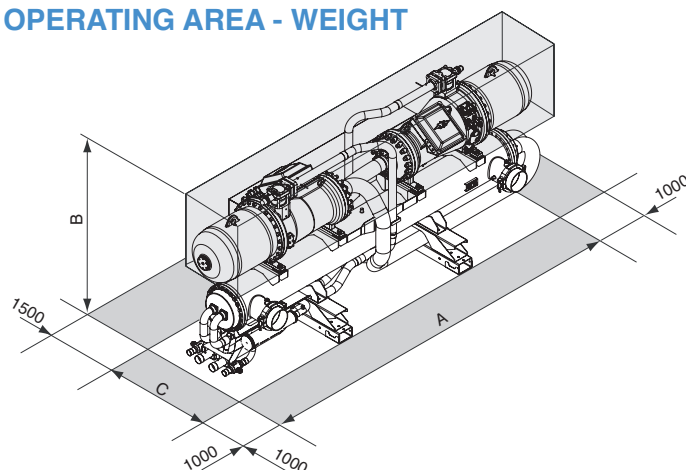

Model	280.1	320.1	360.1	420.1	480.1	540.1	600.1	710.2	820.2	950.2	1100.2	1200.2	
A	3900	3900	3900	3900	3900	3900	3900	4320	4400	4400	4400	4400	mm
B	1845	1845	1845	1880	1880	2045	2045	1845	1880	1880	2045	2045	mm
C	1100	1100	1100	1100	1100	1100	1100	1190	1190	1190	1230	1230	mm
Operating maximum weight	1651	1669	1682	2249	2263	2329	2633	3105	4334	4367	4569	4635	kg

## Remote condenser

This series of Remote Axial Condensers uses copper pipes with special internal rifling and a high efficiency fin.

The fin has been specially designed to guarantee a high thermal exchange coefficient with low air pressure drops. By combining both special tubes and fins the following features can be achieved:

- Maximum capacity related to the heat exchanger's dimensions.
- Minimum refrigerant charge.
- The most strict environment standards for sound pollution can be met.

This new series of axial condensers is equipped with fans with scythe-shaped blades to reduce the sound emission. From the noise level point of view, all models can be supplied as basic version (AB), low noise version (AS) or extra low noise version (AX).

To guarantee solidity, strength and the maximum resistance to atmospheric agents the bearing and the casing are manu-



red with galvanized steel and oven painted with a polyurethane resin (the standard colour is RAL 7035).

### Options

- Special fins (Copper, Painted Aluminium, ecc.).
- Special motors
- Vertical / Horizontal air flow
- EC fans

### Accessories

All models can be equipped with several accessories as:

- Rubber Vibrations Dampers
- Modulating control of the fans with cut of phase regulator
- Modulating control of the fans with inverter regulator
- Electrical Wiring Box, allows a fast and safe electrical installation of the unit since all wires and thermal protections of the fans are connected inside a waterproof box (IP54) to a terminal block where the installer connect the electrical supply and the fans thermal switches signal.
- Electrical Panel CE this accessory (like the electrical wiring box) allows a fast and safe electrical installation and moreover simplify the standard and non standard maintenance of the unit.

The accessory is in fact composed by main electrical switch, fuses and contactors of the fans, transformer to supply an alarm auxiliary relè, terminal block for remote ON-OFF (i.e. sent by the condenserless unit).

### Technical data

Unit	280.1	320.1	360.1	420.1	480.1	540.1	600.1	710.2	820.2	950.2	1100.2	1200.2		
Power supply													400 - 3 - 50	V-ph-Hz
Fan type													axial	-
Max working pressure (PS)													30	bar
Exchanger type													Aluminum fins and copper tubes	-

### Acoustic performances

Base setting up (AB)	280.1	320.1	360.1	420.1	480.1	540.1	600.1	710.2	820.2	950.2	1100.2	1200.2	
Sound power level	86	88	88	88	89	89	90	90	91	91	93	99	dB(A)
Sound pressure level at 1 meter	70	72	72	72	73	73	74	74	74	74	76	82	dB(A)
Sound pressure level at 5 meters	59	61	61	61	62	62	63	63	63	63	65	71	dB(A)
Sound pressure level at 10 meters	54	56	56	56	57	57	58	58	58	58	60	66	dB(A)
Low noise setting up (AS)	280.1	320.1	360.1	420.1	480.1	540.1	600.1	710.2	820.2	950.2	1100.2	1200.2	
Sound power level	81	81	81	82	82	83	83	84	84	86	90	90	dB(A)
Sound pressure level at 1 meter	65	65	65	66	66	67	67	67	67	69	73	73	dB(A)
Sound pressure level at 5 meters	54	54	54	55	55	56	56	56	56	58	62	62	dB(A)
Sound pressure level at 10 meters	49	49	49	50	50	51	51	51	51	53	57	57	dB(A)
eXtra low noise setting up (AX)	280.1	320.1	360.1	420.1	480.1	540.1	600.1	710.2	820.2	950.2	1100.2	1200.2	
Sound power level	74	74	74	75	75	76	76	77	76	76	83	83	dB(A)
Sound pressure level at 1 meter	58	58	58	59	59	59	59	60	59	59	66	66	dB(A)
Sound pressure level at 5 meters	47	47	47	48	48	48	48	49	48	48	55	55	dB(A)
Sound pressure level at 10 meters	42	42	42	43	43	43	43	44	43	43	50	50	dB(A)

**Remote condensers technical data**

<b>Base setting up (AB)</b>		280.1	320.1	360.1	420.1	480.1	540.1	600.1	710.2	820.2	950.2	1100.2	1200.2	
Refrigerant connections	Gas	2x42	2x54	2x54	2x54	2x54	2x54	2x64	2x64	2x76	2x76	2x76	2x76	n° x Ø
	Liquid	2x35	2x42	2x42	2x42	2x35	2x42	2x42	2x42	2x42	2x54	2x54	2x54	n° x Ø
Fan specification	Fan	4	6	6	6	8	8	10	10	12	14	16	12	n°
	Diameter	800	800	800	800	800	800	800	800	800	800	800	900	mm
	Air flow rate	19667	31667	31667	29500	42222	39333	52778	49167	59000	68833	78667	100667	l/s
	Power input	8	12	12	12	16	16	20	20	24	28	32	43.2	kW
Standard configuration	Type	1											2	-
	Length [L]	3230	4580	4580	4580	5930	5930	7280	7280	8630	9980	11330	7990	mm
	Height [A]	2390	2390	2390	2390	2390	2390	2390	2390	2390	2390	2390	2262	mm
	Depth [P]	800	800	800	800	800	800	800	800	800	800	800	2400	mm
	Weight	543	742	742	804	982	1065	1222	1325	1585	1845	2106	2879	kg
Configuration with support brackets	Type	3											-	-
	Length [L]	3230	4580	4580	4580	5930	5930	7280	7280	8630	9980	11330	-	mm
	Height [A]	1565	1565	1565	1565	1565	1565	1565	1565	1565	1565	1565	-	mm
	Depth [P]	2400	2400	2400	2400	2400	2400	2400	2400	2400	2400	2400	-	mm
	Weight	569	768	768	830	1021	1104	1261	1364	1637	1897	2158	-	kg
<b>Low noise setting up (AS)</b>		280.1	320.1	360.1	420.1	480.1	540.1	600.1	710.2	820.2	950.2	1100.2	1200.2	
Refrigerant connections	Gas	2x54	2x54	2x54	2x54	2x54	2x64	2x64	2x76	2x76	2x76	2x76	2x76	n° x Ø
	Liquid	2x42	2x42	2x42	2x35	2x42	2x42	2x42	2x42	2x54	2x54	2x54	2x54	n° x Ø
Fan specification	Fan	6	6	6	8	8	10	10	12	14	16	12	12	n°
	Diameter	800	800	800	800	800	800	800	800	800	800	900	900	mm
	Air flow rate	24667	24667	22500	32889	30000	41111	37500	45000	52500	60000	87000	82333	l/s
	Power input	12	12	7.62	10.16	10.16	12.7	12.7	15.24	17.78	20.32	29.4	29.4	kW
Standard configuration	Type	1											2	-
	Length [L]	4580	4580	4580	5930	5930	7280	7280	8630	9980	11330	7990	7990	mm
	Height [A]	2390	2390	2390	2390	2390	2390	2390	2390	2390	2390	2262	2262	mm
	Depth [P]	800	800	800	800	800	800	800	800	800	800	2400	2400	mm
	Weight	742	742	804	982	1065	1222	1325	1585	1845	2106	2879	3056	kg
Configuration with support brackets	Type	3											-	-
	Length [L]	3230	4580	4580	4580	5930	5930	7280	7280	8630	9980	-	-	mm
	Height [A]	1565	1565	1565	1565	1565	1565	1565	1565	1565	1565	-	-	mm
	Depth [P]	2400	2400	2400	2400	2400	2400	2400	2400	2400	2400	-	-	mm
	Weight	768	768	830	1021	1104	1261	1364	1637	1897	2158	-	-	kg
<b>eXtra low noise setting up (AX)</b>		280.1	320.1	360.1	420.1	480.1	540.1	600.1	710.2	820.2	950.2	1100.2	1200.2	
Refrigerant connections	Gas	2x42	2x54	2x54	2x64	2x64	2x76	2x76	2x76	2x76	2x76	2x76	2x76	n° x Ø
	Liquid	2x35	2x35	2x42	2x42	2x42	2x42	2x54	2x54	2x64	2x64	2x64	2x64	n° x Ø
Fan specification	Fan	8	8	8	10	10	12	14	14	14	14	14	14	n°
	Diameter	800	800	800	800	800	800	800	800	800	900	900	900	mm
	Air flow rate	25778	23111	21333	28889	26667	32000	40444	46222	56389	52500	70000	70000	l/s
	Power input	4.7	4.7	4.7	5.9	5.9	7.1	8.3	9.4	9.5	9.5	15.5	15.5	kW
Standard configuration	Type	1											2	-
	Length [L]	5930	5930	5930	7280	7280	8630	9980	11380	9240	9240	9240	9240	mm
	Height [A]	2390	2390	2390	2390	2390	2390	2390	2390	2262	2262	2262	2262	mm
	Depth [P]	800	800	800	800	800	800	800	800	800	2400	2400	2400	mm
	Weight	900	982	1065	1222	1325	1585	1702	1942	3309	3515	3515	3515	kg
Configuration with support brackets	Type	3											-	-
	Length [L]	5930	5930	5930	7280	7280	8630	9980	11380	9240	9240	-	-	mm
	Height [A]	1565	1565	1565	1565	1565	1565	1565	1565	1565	1565	-	-	mm
	Depth [P]	2400	2400	2400	2400	2400	2400	2400	2400	2400	2400	-	-	mm
	Weight	939	1021	1104	1261	1364	1637	1754	1994	-	-	-	-	kg

**Standard configuration type 1 (horizontal air flow)**

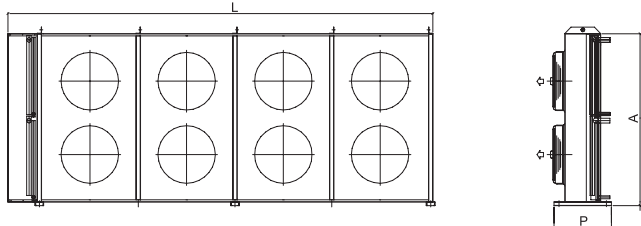

**Standard configuration type 2 (vertical air flow)**

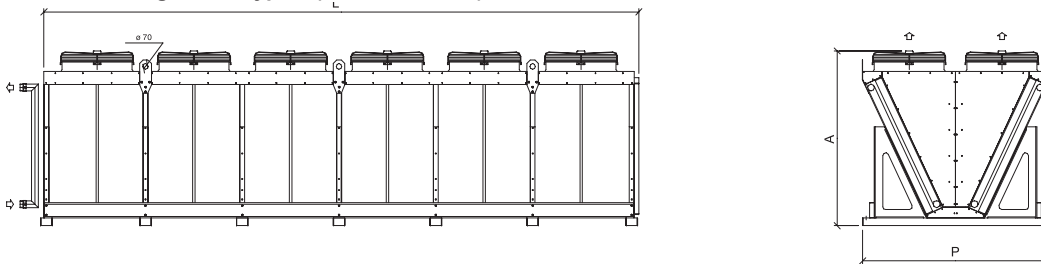

**Configuration with Support Brackets Type 3 (vertical air flow)**

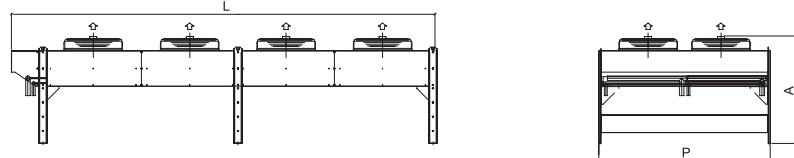



# > Main characteristics terminal units

## 4XUT TERMINAL UNIT MANAGEMENT

The Ferrol team has developed a relay card enabling the management of up to 4 terminal units with a single control.

This is a relay card complete with single multiple contacts to feed the three speeds of the load with the option of controlling the valves for systems with 2 or 4 pipes through another two relays.

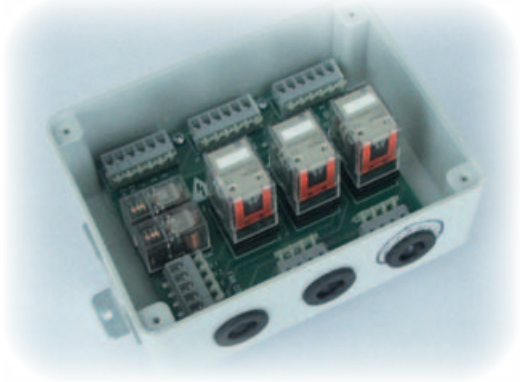

### Technical characteristics

- **ENCLOSURE BOX** : made in plastic suitable for indoor installation.
- **ELECTRONIC BOARD** : positioned on a base, the relay card consists of 2 +3 relays, 6 terminal blocks and cable glands.
- **RELAYS** :
  - 2 single-contact relays for controlling valves (systems with 2 pipes and systems with 4 pipes),
  - 3 multiple-contact type relays for controlling the three fan speeds.
- **TERMINAL BLOCKS** : made in plastic and are complete with a spring device for clamping the electrical wires. To prevent installation errors, the names of the single contacts are given on the board (fig. b).
- **FIXING BRACKET** : The box comes complete with a bracket suitable for fixing to the structure of the Fan Coil TOP FAN (fig. a). Not suitable for other loads or uses.

### 4XUT System Operation

A 4XUT System card can control

- 2, 3, 4 exposed fan coil units VM-B, VM-F with 2 or 4 pipes,
- 2, 3, 4 recessed-mounted units VN-3V, VN or VHF3 with 2 or 4 pipes,
- 2, 3, 4 cassette-type fan coil units FCS with 2 or 4 pipes
- 2, 3, 4 Ducted-type fan coils MERCURY SP, or TCX type.

Each output terminal block must be used for a single load. The control voltage signal from the control, is repeated for a max. of 4 and sent to the loads connected. The electrical connections between control-card and card-terminal units (indicated with dashes in the diagram opposite) are the installer's responsibility.

Fig.a

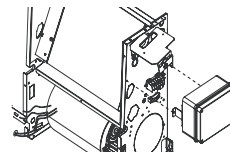
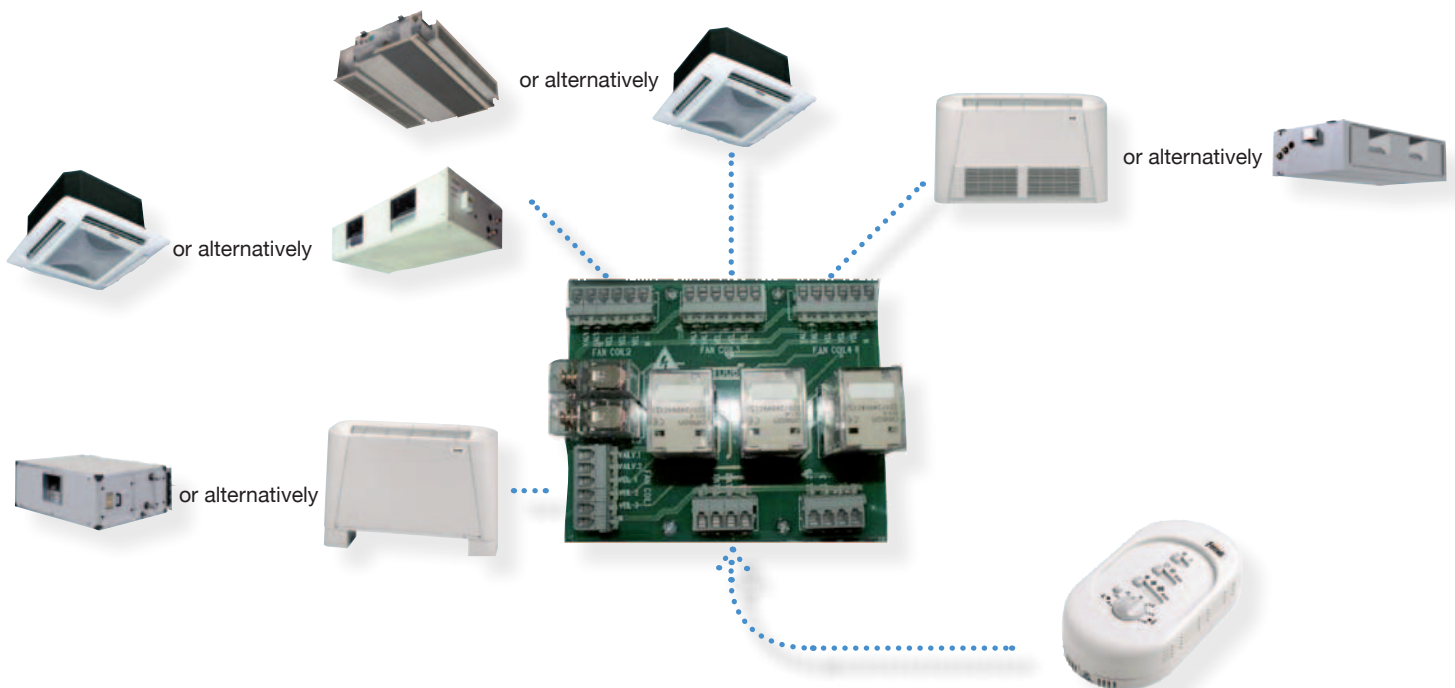

Fig.b



**NB:** To connect more than 4 units, several 4XUT SYSTEM cards must be used. In this case the cards will be connected in parallel, and not the units. For more than 2 cards, the valve control must be taken from the relay of the first card.

# > Main characteristics terminal units

## 8SF MASTER - SLAVE UNIT MANAGEMENT



The electronic thermostat 8SF is widely used in residential and commercial type applications due to the clear adjustment logic and the quick connection between various modules (only 2 wires in dedicated channel).

The 8SF system consists of a room MASTER terminal, a power module to be installed in each unit, an expansion for systems with 4 pipes or with electrical resistance and a further expansion for including a group of 8 units in a central system through KNX language.

### Technical characteristics of components

#### ROOM MASTER

The thermostat 8SF is the UNIT CONTROL and performs the function of MASTER (fig. a).

Wall-mounting is provided for and it is suitable for combining with wall electrical boxes normally available on the market.

Its careful design features a display, showing the manually programmable functions. Using the side buttons the following operations are possible:

- Room set point adjustment,
- Operation mode (heat-cool-Auto) management,
- Fan speed selection (max-med-min-Auto),
- Display of date and time and weekly timer setting.

The connection to the MAIN board is via two screened wires.

Attention must be paid to the installation of these wires and the polarity of the connection terminals.

#### MAIN POWER MODULE

This is the main control of the system and must be installed on every unit (fig. b).

The setting of the parameters done from the wall control is analysed by each power board for a maximum of 8 units.

Using Dip-switches the fan coil units can be configured for:

- System with 2 pipes (and thermostating on valve),
- System with 2 pipes (and thermostating on fan),
- System with 2 pipes + electrical resistance,
- System with 4 pipes.

The functions managed by the power module are:

- Control of 3-speed fan,
- Control of electrothermal-type valves in on/off mode,
- Control of electrical resistance in PWM to optimise energy consumption,
- Monitoring water temperature to define summer/winter change over,
- On/st-by switching via the door/window digital input.

Automatic adjustment Set points

- systems with 2 pipes and seasonal S/W change-over; set point 20°C in heating and 25°C in cooling,
- systems with 4 or 2 pipes + resistance and seasonal S/W change over; set point 21°C in heating and 23°C in cooling,
- antifreeze protection (set point 8°C).

An expansion (Fig. c) can be included in the MAIN power module, for configuration in systems with 4 or 2 pipes+Electrical resistance. The system can be integrated with a further expansion (fig. d), enabling the exchange of information with a centralised plant management system through KNX or MODBUS protocol language. The electrical connections between modules are made with quick connectors, whereas screw-type connections are minimised.

#### LOCAL UNIT

This thermostat, for installation on the unit or wall mounting (to be connected at a max. distance of 3 m) is the SLAVE terminal (fig. e). It enables modification of the parameters set from the MASTER only on the unit to which it is connected, making it partly independent for the choice of Set Point or fan speed with respect to the others. The functions managed are:

- Fan On/off/ speed selection Auto-Low-Medium-High; Auto speed is equivalent to the speed selected by the MASTER,
- Set Point variation cursor (+ or -6°C with respect to the value set in the Master),
- Standby/ON indicator LED
- Availability LEDs for heating (red) and cooling (blue).

Fig.a



Fig.d

Fig.c

Fig.b

Fig.e



## Technical characteristics of components

### AIR PROBE and WATER PROBE

The PROBES (NTC type) read the air or water temperature, depending on where they are placed.

They are connected to the MAIN power module by a quick connector.

In detail:

#### Air PROBE:

- Enables the room temperature of the fan coil on which it is placed to be controlled locally, whereas the others refer to the value read by the MASTER. It is supplied with the SLAVE control.

#### Water PROBE:

- It performs the automatic change-over and HOT START function. It is supplied with the MASTER control (one probe is sufficient for the entire group).

## Operation

### SINGLE UNIT

In OPTION A indicated below, the system is complete with:

- no.1 MASTER control that defines the Set Point values and fan speeds,
- no.1 MAIN power module, installed on the fan coil, which manages the information coming from the control by means of a PI type adjustment algorithm.
- no.1 Water probe, supplied with the MASTER control for the Hot Start function.

### SETTING MAIN BOARD ON EACH SINGLE UNIT

In OPTION B indicated below, the system is complete with

- no.1 - MASTER control that defines the Set Point values and fan speeds,
- no.8 - MAIN power module, installed on the fan coil, which manages the information coming from the control by means of a PI type adjustment algorithm.

Using the Dip-Switches on the MAIN power board it is possible to configure each fan coil in a univocal way:

- FCF 01 configured for system with 2 pipes and thermostating on fan;
- FCF 02 configured for system with 2 pipes and thermostating on valve;
- FCF 03 configured for system with 2 pipes and electrical resistance;
- FCF 04 configured for system with 4 pipes and thermostating on valve;
- FCF 05 configured for system with 2 pipes and thermostating on valve;
- FCF 06 configured for system with 2 pipes and thermostating on valve;
- FCF07 configured for working independently thanks to the connection with the SLAVE control (air probe supplied standard);
- FCF 08 configured for working independently thanks to the connection with the SLAVE control (supplied standard with air probe).

NB: The electrical connection between modules (indicated in dashes and the installer's responsibility) is made with a two-core cable. Pay attention to the installation of this line and the polarity of the connection terminals.

Option A



Option B



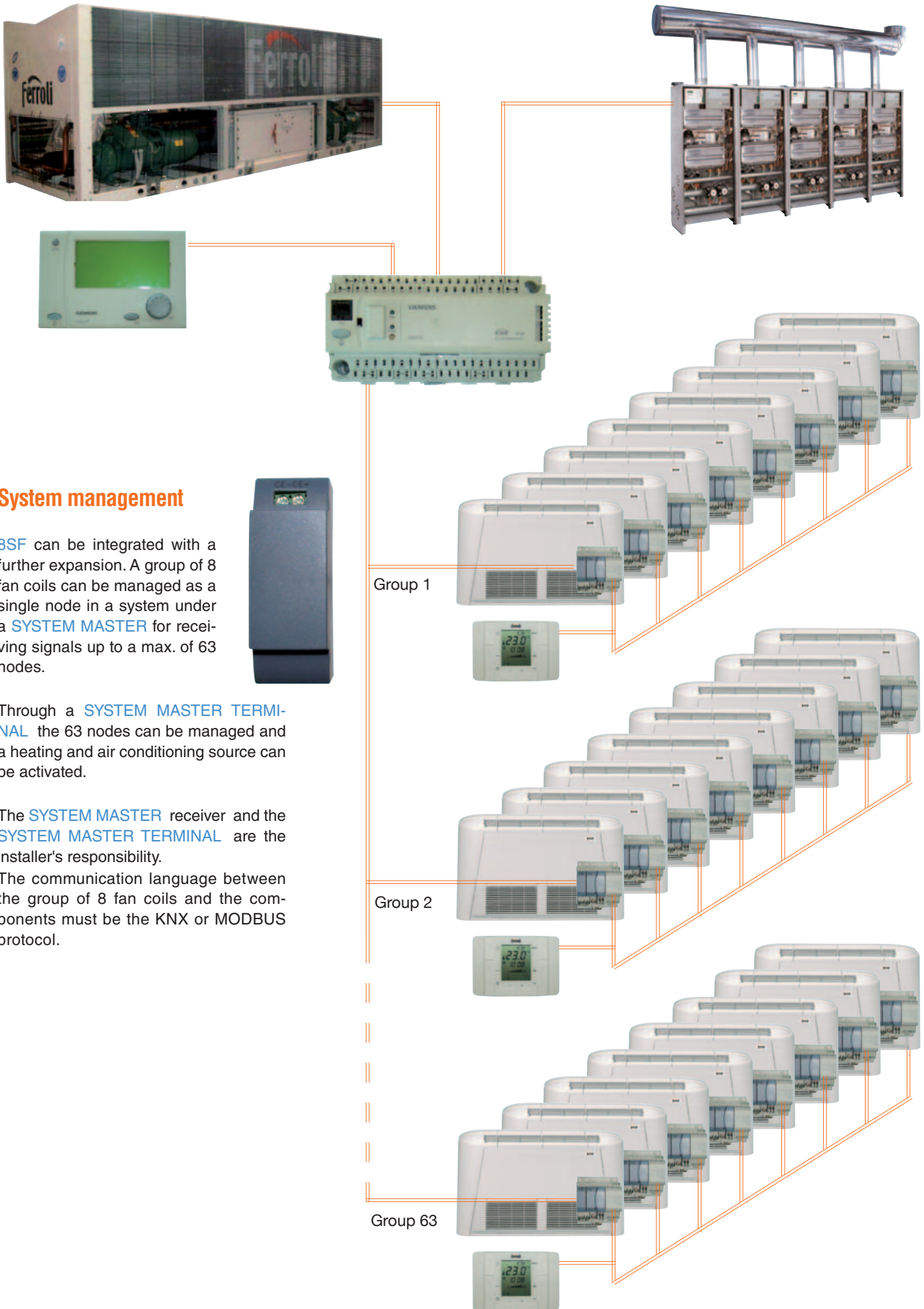

### System management

8SF can be integrated with a further expansion. A group of 8 fan coils can be managed as a single node in a system under a **SYSTEM MASTER** for receiving signals up to a max. of 63 nodes.

Through a **SYSTEM MASTER TERMINAL** the 63 nodes can be managed and a heating and air conditioning source can be activated.

The **SYSTEM MASTER** receiver and the **SYSTEM MASTER TERMINAL** are the installer's responsibility.

The communication language between the group of 8 fan coils and the components must be the KNX or MODBUS protocol.



# > TOP FAN PLUS

## FAN COIL

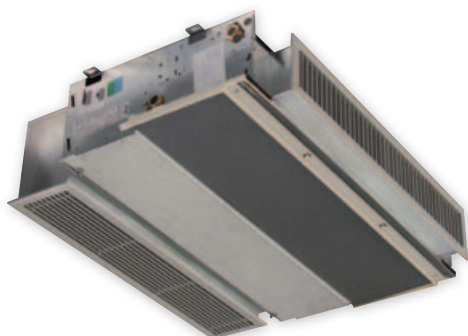
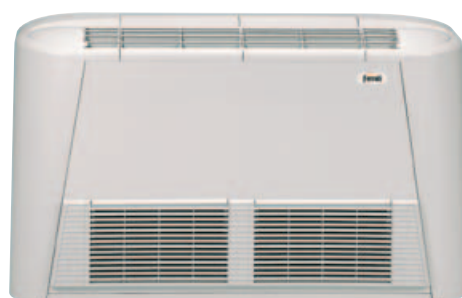

### Units Series

#### Available versions

- VM-B bottom air intake
- VM-F frontal air intake
- VN ceiling concealed 6-speed
- VN-3V ceiling concealed 3-speed

#### Exchangers

- 3R with 3 rows
- 4R with 4 rows

### VB unit specifications

Fan coil unit complying with Machine Directive 89/392 EEC and amendments 91/368 EEC, 93/44 EEC, 93/68 EEC, Low-Voltage Directives 72/23 EEC and Electromagnetic Compatibility Directives EMC 89/36 EEC. The fan coil unit is a terminal for the treatment of room air in the summer season (coil supplied with cold water) and in winter (coil supplied with hot water). These units are suitable for indoor installation, very compact and amply configurable to meet the requirements of highly qualified designers. The customer or the designer can find version with cabinet and with air intake from bottom (VM-B version) or with frontal air intake and version without cabinet ceiling concealed type with 6 speed fan for a short duct (VN version) or with 3 speed fan. The careful design of the main components, refined styling and the versatility of the product make it suitable for any type of installation in the residential, commercial or industrial context. Installation therefore only requires the electrical and hydraulic connections.

#### Construction characteristics

- **SUPPORT STRUCTURE:** in galvanised sheet metal of suitable thickness. There are slots at the back for fixing the unit.
- **HEAT EXCHANGE COIL:** copper pipe type arranged in staggered rows to increase heat exchange and aluminium finning in 3 or 4 rows, locked by mechanical expansion of the pipes. The manifolds have air vents, water drain holes and housing for the supply water temperature probe. The connections are located on the left side panel (facing the unit). The possibility of turning the coil is provided for.
- **CONDENSATE TRAY:** in thermoplastic material to prevent corrosion, it enables either vertical and horizontal unit installation. The drain hole is present on both sides.
- **3-speed FAN-MOTOR (versions VM-B VM-F and VN-3V):** the electric motor, protected against overloads, has three speeds with running condenser always on, directly coupled to the fans and cushioned by elastic supports. The dual-intake centrifugal fans have long blades in order to obtain high air flow-rates with reduced revolutions.
- **6-speed FAN-MOTOR (versions VN):** the electric motor has 6 speeds one or three of which selectable during installation to adjust flow-rate and head to the system's characteristics and enable a short ducting in line with the product's characteristics.

- **AIR FILTER:** regenerable simply by washing with water.  
For the VM-B version it is provided with a continuous guide in plastic material to facilitate extraction operations.  
For the VM-F version it is positioned in the front bottom air inlet grill.  
For the VN and VN-3V version it is complete with frame and wire screen.
- **CABINET (only VM-B and VM-F):** partly in epoxy powder coated steel sheet to ensure high protection against corrosion, and partly in anti-UV thermoplastic material. In the upper part there are air vents and the door for accessing the control panel, both in anti-UV thermoplastic material. The VM-F version also has a front grill in anti-UV thermoplastic material for the air inlet.

## Main accessories/Options

### ADJUSTMENT CONTROLS

#### INSTALLATION ON UNIT

- Cabinet [switch](#)
- Cabinet [standard thermostat](#)
- Cabinet [advanced thermostat](#)

#### REMOTE INSTALLATION

- Remote [switch](#)
- Remote [standard thermostat](#)
- Remote [advanced thermostat](#)

### COMMON ACCESSORIES

- [Hot-start consent thermostat](#)
- [4XUT system](#)
- [8SF Zone Master control](#)
- [8SF main power module](#)
- [8SF Local unit](#)
- [Expansion](#) for systems with 4 pipes
- [Expansion electrical heater management](#)
- [KNX expansion](#)
- [Supplementary tray](#) vertical installation
- [Supplementary tray](#) horizontal installation
- [3-way valve](#) main coil 3-4 R
- [2-way valve](#) main coil 3-4 R
- [Supplementary coil](#) heating only
- [3-way valve](#) supplementary coil
- [2-way valve](#) supplementary coil
- [Single-phase electrical heater](#)
- [Condensate drain pump](#)

### VM-B and VM-F ACCESSORIES

- [Support feet](#) (VM-B only)
- [Adjustable fins](#)
- [Outside air inlet damper](#) with front grill (VM-B only)
- [Damper motor](#) with single-phase power supply (VM-B only)
- [Rear closing panel](#)

### VN and VN-3V ACCESSORIES

- [Inlet grill](#)
- [Straight inlet flange](#)
- [Perpendicular inlet flange](#)
- [Straight outlet flange](#)
- [Perpendicular outlet flange](#)
- [Inlet plenum](#)
- [Outlet plenum](#)
- [Outlet grill](#)

Common Data		15	20	30	40	50	60	80	100	120	
N° fan		1	1	1	1	2	2	2	2	2	N°
Air flow rate	max.	215	280	410	515	615	750	1050	1200	1350	m³/h
	med.	170	210	310	400	510	600	850	970	1070	m³/h
	min	110	140	220	290	350	410	570	670	720	m³/h
VN-3V external static pressure		0	0	0	0	0	0	0	0	0	Pa
VN external static pressure		20	20	40	40	40	50	50	30	30	Pa
Heating capacity electrical heater		800	800	1500	1500	2200	2200	2200	2600	2600	W
VM-B unit weight	3 rows	15	15	21	21	28	28	28	36	36	kg
VM-F unit weight	3 rows	14	14	20	20	27	27	27	34	34	kg
VN e VN-3V unit weight	3 rows	11	11	15	15	22	22	22	29	29	kg
VM-B unit weight	4 rows	15,8	15,8	22,5	22,5	30	30	30	39	39	kg
VM-F unit weight	4 rows	14,8	14,8	21,5	21,5	29	29	29	37	37	kg
VN unit weight	4 rows	11,8	11,8	16,5	16,5	24	24	25	32	32	kg
Condensation draining connections		16	16	16	16	16	16	16	16	16	Ø

## Dimensions

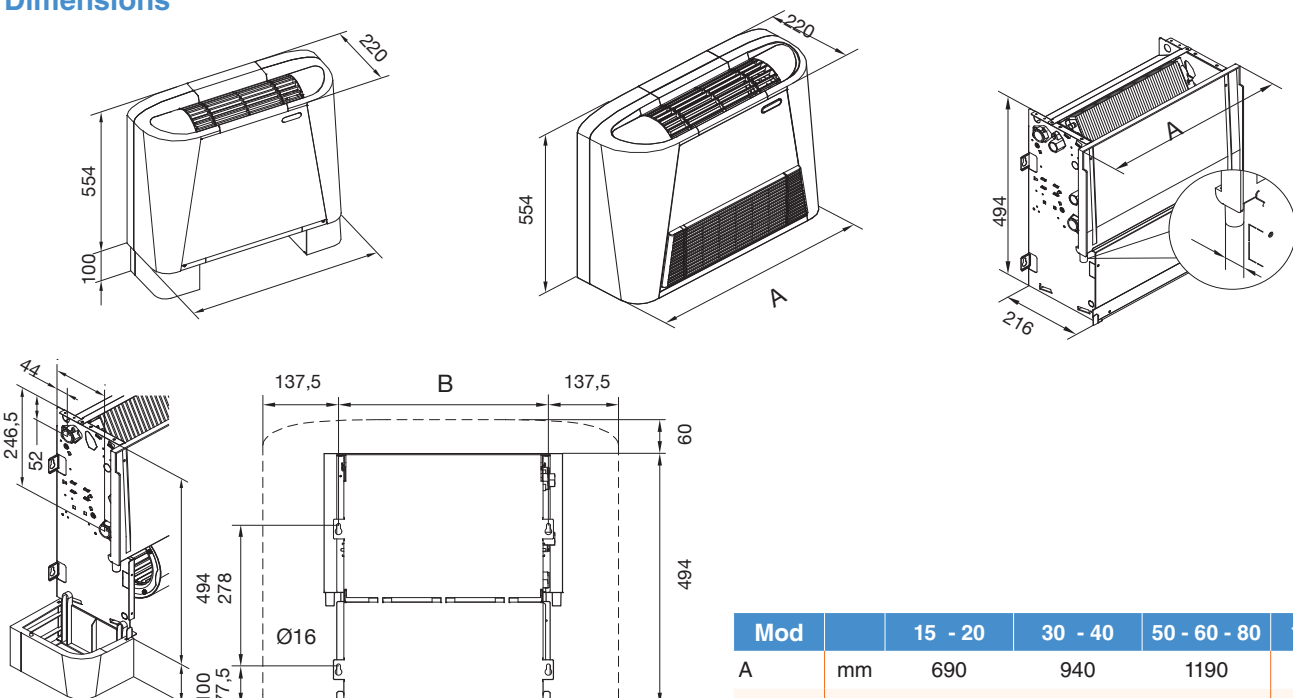

Mod		15 - 20	30 - 40	50 - 60 - 80	100 - 120
A	mm	690	940	1190	1440
B	mm	415	665	915	1165

**3 rows coil data**

		15	20	30	40	50	60	80	100	120	
Total Cooling Capacity *	max. (E)	1100	1400	2100	2800	3400	4000	4900	6100	6850	W
	med.	980	1200	1850	2450	3010	3550	4350	5500	6100	W
	min	770	950	1450	1900	2390	2800	3600	4400	5000	W
Sensible Cooling Capacity *	max. (E)	850	1060	1620	2060	2420	2900	3800	4630	5300	W
	med.	735	910	1400	1780	2245	2550	3350	4045	4630	W
	min	560	705	1090	1390	1710	1985	2735	3155	3720	W
Dehumidifying max speed		350	490	670	1050	1150	1550	1600	2100	2200	g/h
Water flow rate * (E)		189	241	361	482	585	688	843	1049	1178	l/h
Water pressure drop (E)		4,4	6,9	14,6	23	14	18	19,1	9,9	12,5	Kpa
Heating Capacity **	max. (E)	2800	3650	5500	6500	7800	9400	12500	14900	15800	W
	med.	2400	3150	4550	5450	6600	7900	10800	12500	13270	W
	min	1800	2250	3400	4000	4930	5800	8300	9600	10000	W
Water flow rate **		241	314	473	559	671	808	1075	1281	1359	l/h
Water pressure drop **		5,1	8,6	17,6	24,2	14	18,1	17,7	10,8	12,1	Kpa
Heating Capacity *** (E)		1700	2050	3200	3850	4300	5100	7200	8080	9300	W
Water pressure drop ***(E)		3,6	5,3	9,6	15,2	13	14,6	15	8	10,1	Kpa
Heating capacity of supplementary coil	max. (E)	1250	1650	2550	3150	3690	4100	5050	6200	6950	W
	med.	1070	1420	2110	2640	3150	3440	4360	5200	6190	W
	min	860	1130	1750	2150	2320	2820	3480	4250	4800	W
Water flow rate		108	142	219	271	317	353	434	533	598	l/h
Water pressure drop		1,8	3	8,7	13,2	4	4,1	6,88	12,8	16,1	Kpa
N° fan		1	1	1	1	2	2	2	2	2	N°
Max power input motor (E)		30	38	33	60	40	70	120	120	160	W
Sound power level (E)	max.	43	47	50	54	51	55	62	61	64	dB(A)
	med.	39	42	43	48	44	49	57	57	59	dB(A)
	min	32	35	36	41	36	38	48	49	51	dB(A)
Sound pressure level	max.	34	38	41	45	42	46	53	52	55	dB(A)
	med.	30	33	34	39	35	40	48	48	50	dB(A)
	min	23	26	27	32	27	29	39	40	42	dB(A)
Water connection 3R	F	3/4"	3/4"	3/4"	3/4"	3/4"	3/4"	3/4"	3/4"	3/4"	Ø
Water connection 1R	F	1/2"	1/2"	1/2"	1/2"	1/2"	1/2"	1/2"	1/2"	1/2"	Ø
Water content 3R coil		0,82	0,82	1,26	1,26	1,88	1,88	1,88	2,42	2,42	l
Water content 1R coil		0,22	0,22	0,36	0,36	0,5	0,5	0,5	0,64	0,64	l

NOTES:

\* Room Air T=27°C D.B. / 19°C W.B. , IN/OUT water 7°/12°C, nominal air flow-rate; For medium and minimum fan speed, water delivery as in maximum speed.

\*\* Room Air T=20°C D.B. , IN/OUT water 70°/60°C, nominal air flow-rate; for medium and minimum fan speed, water delivery as in maximum speed.

\*\*\* Room Air T=20°C D.B. , inlet water 50°C, water delivery as in cooling; Values referred to nominal air flow-rate.

SWL : Sound power levels, referred to 1x10-12 W in dB(A), measured in accordance with Standard ISO 9614 and certified according to the Eurovent certification programme.

Eurovent certification (E) only refers to the Total Sound Power in dB(A) which is therefore the only binding acoustic data.

SPL : sound pressure in a 100 m3 place with reverberation time of 0.5 seconds.

(E) Declared data according to the certification programme LCP EUROVENT

4 rows coil data

		15-4	20-4	30-4	40-4	50-4	60-4	80-4	100-4	120-4	
Total Cooling Capacity *	max.	1400	1760	2790	3580	4050	4890	6450	7450	8200	W
	med.	1220	1460	2290	2940	3510	4020	5680	6620	7160	W
	min	900	1090	1700	2200	2500	2980	4000	5020	5250	W
Sensible Cooling Capacity *	max.	1050	1305	2060	2580	2950	3540	4950	5580	6210	W
	med.	890	1050	1640	2070	2510	2900	4200	4850	5330	W
	min	620	770	1200	1560	1770	2130	2910	3600	3820	W
Dehumidifying max speed		500	650	1050	1450	1580	1930	2330	2650	2850	g/h
Water flow rate *		240,8	302,72	479,88	615,76	696,6	841,08	1109,4	1281,4	1410,4	l/h
Water pressure drop		6	9	9	14	14	21	36	19	23	Kpa
Heating Capacity **	max.	3050	3950	5880	6950	8350	10100	13200	15800	16900	W
	med.	2580	3300	4730	5750	7260	8270	11300	13400	14310	W
	min	1900	2400	3600	4430	5460	6080	8450	10250	10500	W
Water flow rate **		262,3	339,7	505,68	597,7	718,1	868,6	1135,2	1358,8	1453,4	l/h
Water pressure drop **		5	8	7	10	11	16	27	15	18	Kpa
Heating Capacity ***		1850	2380	3460	4250	5000	5800	8100	9300	10500	W
Water pressure drop ***		5	8	8	13	12	18	32	16	20	Kpa
N° fans		1	1	1	2	2	2	2	2	2	N°
Max power input motor		35	38	55	76	75	85	144	163	200	W
Sound power level	max.	45	48	52	54	53	55	61	63	65	dB(A)
	med.	39	42	45	47	46	50	58	59	60	dB(A)
	min	32	35	39	41	37	39	48	51	52	dB(A)
Sound pressure level	max.	36	39	43	45	44	46	52	54	56	dB(A)
	med.	30	33	36	38	37	41	49	50	51	dB(A)
	min	23	26	30	32	28	30	39	42	43	dB(A)
Water connection 4R		F	3/4"	3/4"	3/4"	3/4"	3/4"	3/4"	3/4"	3/4"	"
Water content 4R coil		1,09	1,09	1,68	1,68	2,51	2,51	2,51	3,23	3,23	l

NOTES:

\* Room Air T=27°C D.B. / 19°C W.B. , IN/OUT water 7°/12°C, nominal air flow-rate; For medium and minimum fan speed, water delivery as in maximum speed.

\*\* Room Air T=20°C D.B. , IN/OUT water 70°/60°C, nominal air flow-rate; for medium and minimum fan speed, water delivery as in maximum speed.

\*\*\* Room Air T=20°C D.B. , inlet water 50°C, water delivery as in cooling; Values referred to nominal air flow-rate.

SWL : Sound power levels, referred to 1x10-12 W in dB(A), measured in accordance with Standard ISO 9614 and certified according to the Eurovent certification programme.

Eurovent certification (E) only refers to the Total Sound Power in dB(A) which is therefore the only binding acoustic data.

SPL : sound pressure in a 100 m3 place with reverberation time of 0.5 seconds.



# > FCS

## FAN COIL CASSETTE TYPE



### Units Series

#### Unit type

- 2T 2 pipes systems
- 4T 4 pipes systems

#### Unit version

- Standard control wire
- Rem infrared control

### Unit specifications

Fan coil cassette type unit complying with Machine Directive 89/392 EEC and amendments 91/368 EEC, 93/44 EEC, 93/68 EEC, Low-Voltage Directives 72/23 EEC and Electromagnetic Compatibility Directives EMC 89/36 EEC.

The cassette type fan coil unit is a terminal for the treatment of room air in the summer season (coil supplied with cold water) and in winter (coil supplied with hot water). These units are suitable for indoor installation, very compact and amply configurable to meet the requirements of highly qualified designers.

The centrifugal-axial fan allows the intake and outlet side of the 4 outputs contained to reduce the noise levels.

The careful design of the main components, refined styling and the versatility of the product make it suitable for any type of installation in the residential, commercial or industrial context.

Installation therefore only requires the electrical and hydraulic connections.

### Construction characteristics of versions

- **SUPPORT STRUCTURE:** in galvanised steel sheet, insulated externally and internally to prevent heat loss and condensation.
- **HEAT EXCHANGE COIL:** made with copper pipes arranged in staggered rows and with corrugated aluminium finning, locked by mechanical expansion of the pipes.
- **FRONT GRILL:** in thermoplastic material, consisting of an attractively designed inlet grill complete with filter and four air-flow diverting fins. Intake occurs in the middle part of the grill, whereas delivery occurs through the manually-adjustable perimeter slots.
- **AIR FILTER:** situated inside the inlet grill and easily removed, it is made from regenerable materials, cleanable simply by washing.
- **CONDENSATE TRAY:** in plastic material, of considerable capacity complete with condensate drain pipe sized for elimination of the water even in critical conditions. A device that raises the condensate from the collection tray to the drain level is fitted standard.
- **FAN MOTOR:** no.1 directly coupled type, the unit is equipped with a three-speed motor with internal thermal protection and a mixed flow fan (axial-centrifugal) in plastic material. Single-phase power supply T=230V.
- **ELECTRIC BOARD:** fitted inside the unit for easy access during installation, complete with connectors for quick electrical connections.

### Installation options

The units have pre-cut side openings allowing the unit to be connected by means of a intake duct to a grill for external air change, or conveying treated air to an adjoining room.

### Main accessories/Options

- Remote switch
- Remote standard thermostat
- Remote advanced thermostat
- Hot-start consent thermostat
- 4XUT system
- Main coil 3-way valve
- Supplementary coil 3-way valve

MODELLO		04	08	10	12	16	20	04-4T	10-4T	20-4T		
Versione		2 Tubi						4 Tubi				
Potenza frigorifera (1)	max	2400	4000	4700	6300	7600	10000	1900	4000	9800	W	
	med	1800	2850	3500	4500	5100	7100	1430	3050	7300	W	
	min	1550	1900	2850	3400	3170	3900	1230	2500	4100	W	
Portata acqua (2)		0,11	0,19	0,22	0,30	0,36	0,48	0,09	0,19	0,47	l/s	
Perdite di carico lato acqua (1)(2)		9	12	20	22	14	24	10,8	19,7	30	kPa	
	max	3800	5000	6600	8700	10800	13900	-	-	-	W	
	med	3000	4090	4800	6300	7300	10000	-	-	-	W	
Portata acqua (3)	min	2600	2410	4050	4700	4300	5400	-	-	-	W	
		0,11	0,19	0,22	0,30	0,36	0,48	-	-	-	l/s	
	max	7110	9770	11760	14600	18000	24500	1900	4610	9000	W	
Potenza Termica (4)	med	5600	8000	8500	10800	13200	17500	1440	3500	7900	W	
	min	4850	4700	7200	8200	8400	9850	1240	2730	5100	W	
		0,17	0,23	0,28	0,35	0,43	0,6	0,05	0,11	0,22	l/s	
Alimentazione		230-1-50						V-F-Hz				
Portata d'aria ventilatore interno	max	660	700	850	1100	1300	1750	660	850	1750	m <sup>3</sup> /h	
	med	450	490	600	770	910	1220	450	600	1220	m <sup>3</sup> /h	
	min	360	300	470	550	550	700	360	470	700	m <sup>3</sup> /h	
Potenza sonora	max	49	54	57	49	56	63	49	58	63	dB(A)	
	med	38	45	48	40	49	55	38	50	55	dB(A)	
	min	33	32	42	34	40	42	33	42	42	dB(A)	
Pressione sonora (5)	max	41	46	49	41	48	55	41	50	55	dB(A)	
	med	30	37	40	32	41	47	30	42	47	dB(A)	
	min	25	24	34	26	32	34	25	34	34	dB(A)	
Potenza assorbita	max	70	85	95	85	120	200	70	110	200	W	
	med	45	55	75	51	75	140	45	75	140	W	
	min	35	35	55	33	40	70	35	55	70	W	
N° ventilatori		1						n°				
Peso unità completa di kit griglia		21,5	22,5	22,5	46	48	51	21,5	22,5	51	kg	
Attacchi idraulici		3/4	3/4	3/4	1	1	1	3/4	3/4	1	"	
Attacchi scarico condensa(6)		25	25	25	25	25	25	25	25	25	mm	

**NOTES:**

- \* Room Air T=27°C D.B. / 19°C W.B. , IN/OUT water 7°/12°C, nominal air flow-rate; For medium and minimum fan speed, water delivery as in maximum speed.
- \*\* Room Air T=20°C D.B. , IN/OUT water 70°/60°C, nominal air flow-rate; for medium and minimum fan speed, water delivery as in maximum speed.
- \*\*\* Room Air T=20°C D.B. , inlet water 50°C, water delivery as in cooling; Values referred to nominal air flow-rate.
- SWL : Sound power levels, referred to 1x10-12 W in dB(A), measured in accordance with Standard ISO 9614 and certified according to the Eurovent certification programme. Eurovent certification (E) only refers to the Total Sound Power in dB(A) which is therefore the only binding acoustic data.
- SPL : sound pressure in a 100 m<sup>3</sup> place with reverberation time of 0.5 seconds.
- (E) Declared data according to the certification programme LCP EUROVENT

**Overall dimensions**

Mod. 04-08-10

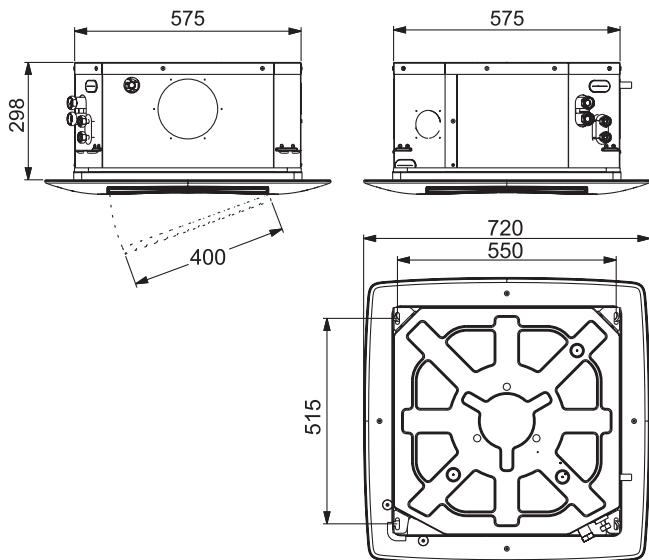

Mod. 12-16-20

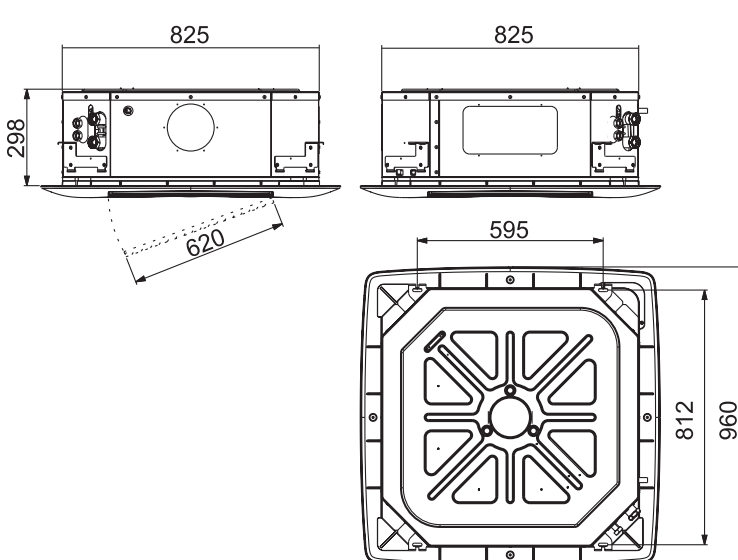



## STANDARD VERSION

The accessories available for this category are:

### · Command and Control panels

A number of panels are available for remote wall-mounting, comprising three different types of control, switch, basic thermostat and evolved thermostat.

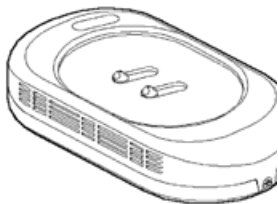
The table gives the various control panels available, with their main functions.

	CMR-F - Remote switch	TAR-F - Remote standard thermostat	TER-F - Remote advanced thermostat
Panel type			
Main Functions	<ul style="list-style-type: none"> <li>- Unit On/Off</li> <li>- Speed manual selection</li> </ul>	<ul style="list-style-type: none"> <li>- Unit On/Off</li> <li>- Fan speed manual selection (3 speeds)</li> <li>- Heating/cooling mode manual/automatic selection</li> <li>- Set point</li> </ul>	<ul style="list-style-type: none"> <li>- Unit On/Off</li> <li>- Fan speed manual selection (3 speeds)</li> <li>- Heating/cooling mode manual/automatic selection</li> <li>- Set point</li> </ul>

### · VTV - 3-way valve (compulsory for operation in cooling mode)

The valve is necessary for controlling the room temperature, and for shutting off the flow of chilled water to the coil in case of an anomalous rise in the condensation water level.

The use of this valve is compulsory if the unit is used in summer Cooling mode, to avoid excessive cooling of the unit when the fan is stopped and therefore prevent condensate forming on the casing of the machine.

The kit is complete with copper fittings and 3-way valves with ON/OFF electrothermal actuator, arranged for 230V power supply and thermal insulator.

The valve is controlled by the above-mentioned series of thermostats.

Two 3-way valves are necessary for the version with 4 Tubes.

### · TC-F - Consent thermostat

This accessory must be combined with the "switch" control panel and allows fan activation to be disabled whenever the coil temperature has not reached acceptable working values during operation in heating mode.

## ACCESSORIES COMBINATION

Version		2 PIPE SYSTEM						4 PIPE SYSTEM		
ACCESSORY		04	08	10	12	16	20	04-4T	10-4T	20-4T
CONTROLS	CMR-F	•	•	•	•	•	•			
	TAR-F	•	•	•	•	•	•			
	TER-F							•	•	•
3-WAY VALVE	VTV 1 B	•	•	•				•	•	
	VTV 2 B				•	•	•			•
	VTV 3 B(1)							•	•	
	VTV 2 B									•
HOT-START CONSENT THERMOSTAT	TC-F (NB)	•	•	•	•	•	•			

(1): 3-way valve for Secondary Coil of versions with 4 pipes.

(NB): Combinable only with Remote Switch (CMR-F).

**REM B VERSION**

Fig. 1

The remote control (Fig. 1) has a series of keys and a display which visualizes all the activated functions and the various parameters the user and installer need in order to correctly use the unit itself

1) Display. Display the setting condition

Keys functions Fig 1 descriptions

- A. key to select the operating mode
- B. key to turn the air conditioner on and off
- C. keys to adjust ambient temperature and the timer: (▲) to increase
- D. keys to adjust ambient temperature and the timer: (▼) to decrease
- E. key to set the fan speed by the choosing Automatic - low - mid - high.
- F. Personalised control button
- G. Personalised settings button
- H. Louvre control button
- I. ON timer button
- J. daily timer button (Everyday)
- K. Cancel timer button
- L. OFF timer button
- M. overnight button to set/cancel the Sleep mode regardless of the operating mode of the conditioner
- N Current time adjusting button
- O. Reset Key

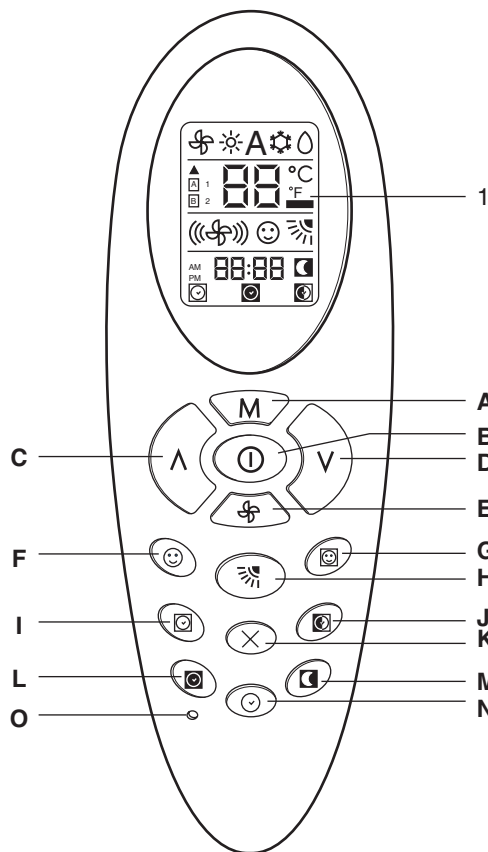

**Display of selected functions Fig 2**

1. Operating mode (from left to right):

- Ventilation (fan only)
  - Heating (According to the unit configuration)
  - Automatic (According to the unit configuration)
  - Cooling and dehumidification
  - Dehumidification only
2. Signal transmission symbol
3. Temperature selected
4. Address selector
5. Temperature unit of measurement (°C or °F)
6. Unit configuration
7. Batteries exhausted indicator
8. Louvre positioning (Flap)
9. Fan speed
10. Personalisation active
11. ON timer selected
12. Night timer active
13. Daily timer active (Everyday)
14. ON timer, OFF timer and current time
15. OFF timer selected

Fig. 2

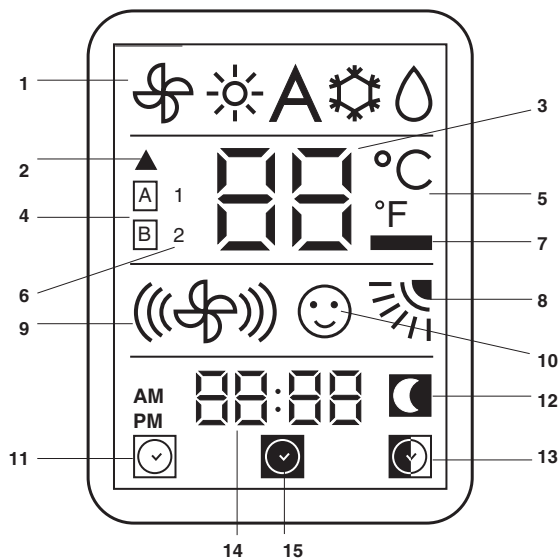

**ACCESSORIES COMBINATION**

Version		2 PIPE SYSTEM						4 PIPE SYSTEM		
ACCESSORY		04	08	10	12	16	20	04-4T	10-4T	20-4T
3-WAY VALVE	VTV 1 B	•	•	•				•	•	
	VTV 2 B				•	•	•			•
	VTV 3 B (1)							•	•	
	VTV 2 B									•

(1): 3-way valve for Secondary Coil of versions with 4 pipes.





### TOP FAN remote control specifications

Remote control with LCD display complete with support bracket for wall fixing. enabling the following functions:

- Unit ON/OFF
- Operation mode selection
  - Auto, Heat, Cool, Fan (only if the valve accessory is present)
- Ventilation speed
  - Max, Med, Min, Auto
- Set Point
- Timer

The remote control display shows:

- Operation mode
- Selected fan speed
- Set point value
- Timer activation
- Time setting



Also available for VHF3

### FCS remote control specifications

Remote control with LCD display complete with support bracket for wall fixing. enabling the following functions:

- Unit ON/OFF
- Operation mode selection
  - Auto, Heat, Cool, Fan (only if valve accessory is present)
- Ventilation speed
  - Max, Med, Min, Auto
- Set-Point
- Air Sweep for air flow adjustment
- Timer

The remote control display shows:

- Operation mode
- Selected fan speed
- Set point value
- Timer activation
- Time setting
- Signal sent symbol
- Fin position



### Exposed TOP FAN fan coil receiver

Positioned on the front panel of the unit, it is complete with Timer LED (yellow), On LED (green) and emergency ON/OFF button and reception zone.

The system is completed with the board inside the unit. The system is supplied already factory-tested and installed.



### Ceiling concealed TOP FAN wall receiver

The receiver is supplied in case of ceiling concealed units and is positioned exposed on the false ceiling. It is complete with Timer LED (yellow), On LED (green) and emergency ON/OFF button and reception zone.

It comes with a multicore cable (max. length 0.8 m) for quick connection and electronic board for installing on the unit. The system is factory-tested, whereas positioning the receiver is up to the installer.





# > VHF3

## CEILING CONCEALED FAN COIL



### Units Series

Type unit	
VHF3 2T	2 pipes systems
VHF3 4T	4 pipes systems

### Unit specifications

Ceiling concealed fan coil, complying with Machine Directive 89/392 EEC and amendments 91/368 EEC, 93/44 EEC, 93/68 EEC, Low-Voltage Directives 72/23 EEC and Electromagnetic Compatibility Directives EMC 89/36 EEC.

The ceiling concealed fan coil unit terminal for the treatment of room air in the summer season (coil supplied with cold water) and in winter (coil supplied with hot water).

These units are suitable for indoor installation, very compact and are built to adapt to the various types of system design and meet the requirements of highly qualified designers.

The careful design of the main components, refined styling and the flexibility of the product make it suitable for any type of installation in residential, commercial or industrial applications.

Installation therefore only requires the electrical and hydraulic connections.

### Construction characteristics of versions

- **SUPPORT STRUCTURE:** in aluzink sheet, lined with a suitable thickness of polyethylene and polyester to prevent heat loss, condensation and for soundproofing.
- **AIR FILTER:** easily removed from bottom or side, it can be cleaned simply by washing with water.
- **HEAT EXCHANGE COIL:** made with copper pipes arranged in staggered rows to increase heat exchange efficiency along with aluminium fins, locked by the expansion of the pipes during production. Complete with water inlet/outlet manifolds.
- **CONDENSATE TRAY:** made in galvanized sheet steel, complete with section for connection to the discharge line.
- **FAN MOTOR:** direct drive type, the unit is equipped with a three-speed fan motor assembly with internal thermal protection and a startup capacitor always on, with a blade that is statically and dynamically balanced to minimise noise and vibration.
- **ELECTRICAL CONNECTIONS:** The unit comes complete with a protected electrical terminal block for making the connection to the various available adjustment controls.

### Main accessories/Options

- Remote switch
- Remote standard thermostat
- Remote advanced thermostat
- Hot-start consent thermostat
- 4XUT system
- Relay Kit
- 8SF Zone Master control
- 8SF main power module
- 8SF local unit
- Expansion for systems with 4 pipes
- Expansion for electrical resistance management
- KNX expansion
- Supplementary tray
- Main coil 3-way valve
- Outlet plenum
- Inlet grill
- Inlet plenum
- Outlet grill
- Standard air filter
- Air filter Class G2
- REM

NB: In case of electrical connection of the unit to Ferrolti thermostats, the unit must be fitted with the relay kit accessory (KR).

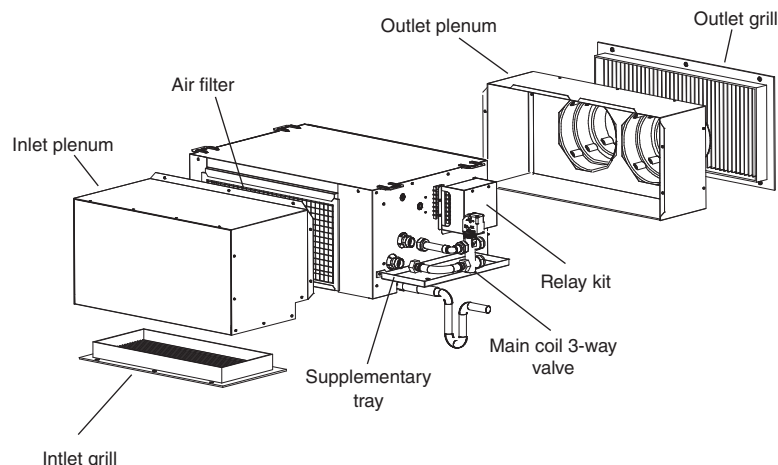



Common data		05	08	10	12	14	19	21	28	
		2T - 4T	2T - 4T	2T - 4T	2T - 4T	2T - 4T	2T - 4T	2T - 4T	2T - 4T	
Air flow rate	Max	800	1.100	1.300	1.750	1.800	2.700	3.400	4.000	m³/h
	Med	630	850	950	1.100	1.150	2.250	2.700	3.400	m³/h
	Min	430	630	730	750	800	1.700	2.100	2.900	m³/h
External static pressure****		50	50	50	50	50	50	50	50	Pa
Supply		230-150								V-Ph-Hz
N° fans		1	2	2	2	2	2	2	2	N°
N° motor		1	1	1	1	1	1	1	1	N°
n° speed		3	3	3	3	3	3	3	3	N°
Power input motor		100	109	115	220	225	345	450	730	W
2 - PIPES		05-2T	08-2T	10-2T	12-2T	14-2T	19-2T	23-2T	28-2T	
Heating Capacity *	Max	5.800	9.900	10.900	14.300	16.100	22.300	27.200	32.600	W
	Med	4.850	7.850	8.550	9.650	10.500	19.200	23.400	29.900	W
	Min	3.600	6.050	6.700	6.900	7.200	15.700	20.200	26.200	W
Water flow rate*		826	1.393	1.703	2.116	2.356	3.285	3.922	4.799	l/h
Water pressure drop *		29	32	40	46	34	42	37	38	kPa
Cooling Capacity ***	Total	4.800	8.100	9.900	12.300	13.700	19.100	22.800	27.900	W
	Sensible	3.460	5.600	6.800	8.590	9.540	13.400	16.400	19.700	W
	Total	4.200	7.150	7.800	9.100	9.800	16.800	20.100	25.600	W
	Sensible	2.950	4.830	5.240	6.100	6.650	11.550	14.100	17.900	W
	Total	3.250	5.700	6.150	6.500	6.950	14.200	17.800	23.700	W
	Sensible	2.200	3.780	4.050	4.280	4.550	9.560	12.250	16.330	W
Water flow rate		826	1.393	1.703	2.116	2.356	3.285	3.922	4.799	l/h
Water pressure drop		35	39	49	56	42	52	45	47	kPa
N° Rows coil		3	4	4	4	4	4	4	4	N°
Water content		1,11	2,63	3,11	3,34	4,45	4,67	6	7,51	l
Water connection		F 3/4"	3/4"	3/4"	3/4"	3/4"	3/4"	3/4"	3/4"	"
Weight unit		20	32	35	48	52	61	68	81	kg
4 - PIPES		05-4T	08-4T	10-4T	12-4T	14-4T	19-4T	23-4T	28-4T	
Heating Capacity **	Max	4.050	6.100	7.450	9.450	11.550	14.000	17.900	21.300	W
	Med	3.400	4.950	5.800	6.700	8.200	12.300	15.400	18.800	W
	Min	2.600	3.900	4.600	4.800	5.900	10.100	12.600	16.800	W
Water flow rate **		348	525	641	813	993	1.204	1.539	1.832	l/h
Water pressure drop **		34	11	20	10	24	11	30	24	kPa
Cooling Capacity ***	Total	3.450	6.700	7.950	9.850	11.700	14.800	18.400	22.100	W
	Sensible	2.850	5.180	6.050	7.700	9.050	11.750	14.520	17.250	W
	Total	3.100	5.700	6.500	7.500	9.000	13.300	16.200	20.300	W
	Sensible	2.450	4.300	4.840	5.540	6.700	10.350	12.480	15.520	W
	Total	2.500	4.720	5.400	5.500	6.900	11.250	14.050	18.600	W
	Sensible	1.940	3.450	3.940	4.100	4.980	8.450	10.450	14.050	W
Water flow rate***		593	1.152	1.367	1.694	2.012	2.546	3.165	3.801	l/h
Water pressure drop **		36	38	28	48	34	34	36	34	kPa
N° Rows heating coil		1	1	1	1	1	1	1	1	N°
Water content heating coil		0,37	0,66	0,78	0,84	1,11	1,17	1,5	1,88	l
Water connection heating coil		F 3/4"	3/4"	3/4"	3/4"	3/4"	3/4"	3/4"	3/4"	"
N° Rows cooling coil		2	3	3	3	3	3	3	3	N°
Water content cooling coil		0,74	1,97	2,33	2,51	3,34	3,5	4,5	5,63	l
Water connection cooling coil		F 3/4"	3/4"	3/4"	3/4"	3/4"	3/4"	3/4"	3/4"	"
Weight unit		21	33	36	49	53	63	70	83	kg

NOTES:

- \*\*\* Room Air T=27°C D.B. / 19°C W.B. , IN/OUT water 7°/12°C, nominal air flow-rate; For medium and minimum fan speed, water delivery as in maximum speed.
- \*\* Room Air T=20°C D.B. , IN/OUT water 70°/60°C, nominal air flow-rate; for medium and minimum fan speed, water delivery as in maximum speed.
- \* Room Air T=20°C D.B. , inlet water 50°C, water delivery as in cooling; Values referred to nominal air flow-rate.
- \*\*\*\* Units at various speeds without filter

Dimensions

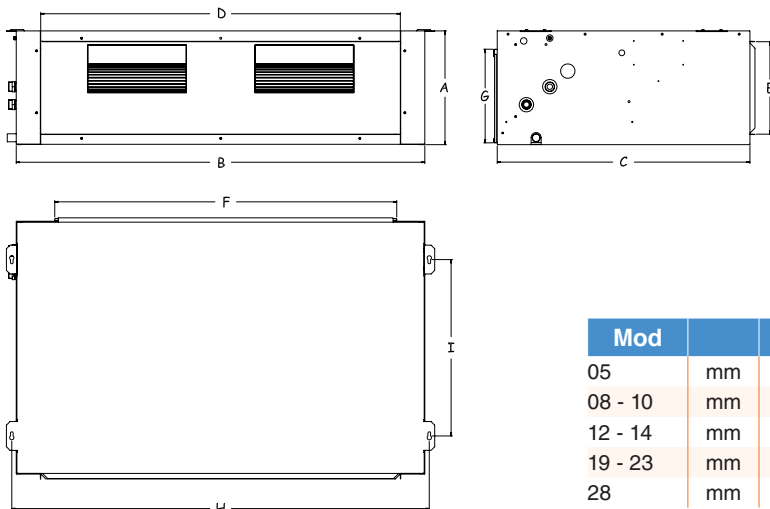

Mod		A	B	C	D	E	F	G	H	I
05	mm	290	640	475	550	235	475	260	665	320
08 - 10	mm	290	1005	650	915	235	950	260	1030	430
12 - 14	mm	319	1135	700	1000	260	950	260	1160	480
19 - 23	mm	360	1330	765	1200	300	1300	320	1355	540
28	mm	360	1635	765	1200	300	1300	320	1660	540



# > MERCURY SP

## DUCTED FAN COIL



### Units Series

Type unit  
**MERCURY SP** horizontal unit

### Unit specifications

Ducted fan coil complying with Machine Directive 89/392 EEC and amendments 91/368 EEC, 93/44 EEC, 93/68 EEC, Low-Voltage Directives 72/23 EEC and Electromagnetic Compatibility Directives EMC 89/36 EEC.

The ducted fan coil unit is a terminal for the treatment of room air in the summer season (coil supplied with cold water) and in winter (coil supplied with hot water).

These units are suitable for indoor installation, very compact and amply configurable to meet the requirements of highly qualified designers.

The careful design of the main components, refined styling and the versatility of the product make it suitable for any type of installation in the residential, commercial or industrial context.

Installation therefore only requires the electrical and hydraulic connections.

### Construction characteristics

- **SUPPORT STRUCTURE:** in aluzink sheet, lined with a suitable thickness of polyethylene and polyester to prevent heat loss, condensation and for soundproofing.
- **AIR FILTER:** easily removed from bottom or side, it can be cleaned simply by washing with water.
- **HEAT EXCHANGE COIL:** made with copper pipes arranged in staggered rows to increase heat exchange efficiency along with aluminium fins, locked by the expansion of the pipes during production. Complete with water inlet/outlet manifolds.
- **CONDENSATE TRAY:** made in galvanised sheet steel, complete with section for connection to the discharge line.
- **FAN MOTOR:** direct drive type, the unit is equipped with a three-speed fan motor assembly with internal thermal protection and a startup capacitor always on, with a blade that is statically and dynamically balanced to minimise noise and vibration.
- **ELECTRICAL CONNECTIONS:** The unit comes complete with protected electrical terminal block for making the connection to the various available adjustment controls.

### Main accessories/Options

- Remote switch
- Remote standard thermostat
- Remote advanced thermostat
- Hot-start consent thermostat
- 4XUT system
- Relay Kit
- 8SF Zone Master control
- 8SF main power module
- 8SF local unit
- Expansion for systems with 4 pipes
- Expansion for electrical resistance management
- KNX expansion
- Supplementary tray
- Main coil 3-way valve
- Post heating section
- Post-heating 3-way valve
- Outlet plenum
- Inlet grill
- Inlet plenum
- Outlet grill
- Standard air filter
- Air filter Class G2

NB: In case of electrical connection of the unit to Ferroli thermostats, the unit must be fitted with the relay kit accessory (KR).

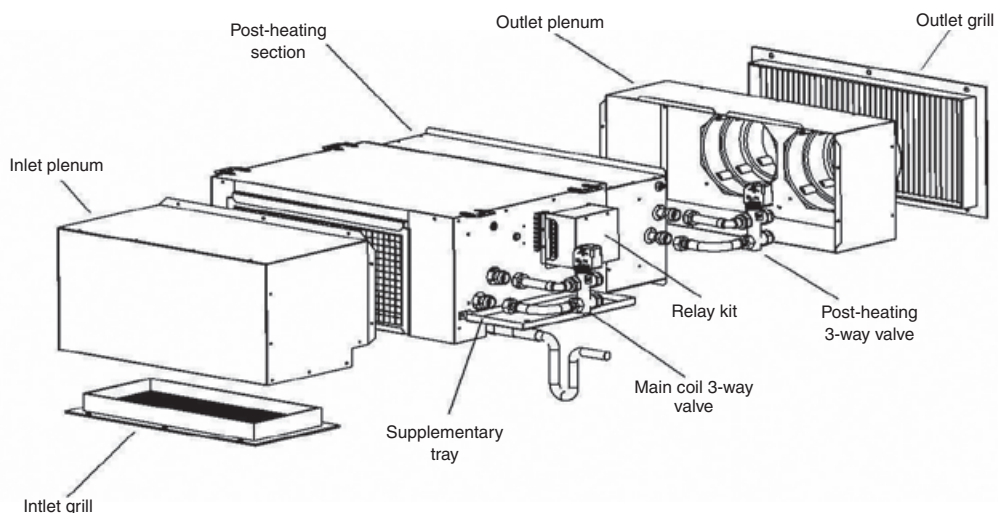

		05	07	11	13	17	19	21	23		
Cooling Capacity *	Max.	5.042	7.909	9.111	10.326	13.327	16.375	20.943	23.118	W	
	Med.	4.882	7.423	8.667	9.393	11.847	12.839	20.472	22.502	W	
	Min.	4.478	6.208	7.171	8.302	10.163	9.369	19.355	21.063	W	
Water flow rate*		870	1.364	1.573	1.782	2.304	2.826	3.613	3.988	L/h	
Water pressure drop *		39	38	34	40	40	39	38	34	Kpa	
Heating Capacity **	Max.	5.598	8.158	9.379	10.598	13.571	17.222	22.037	23.950	W	
	Med.	5.330	7.643	8.766	9.403	11.769	12.440	21.376	23.095	W	
	Min.	4.981	6.330	6.855	7.984	9.634	8.508	19.784	21.178	W	
Water flow rate **		963	1.404	1.614	1.823	2.335	2.963	3.791	4.120	L/h	
Water pressure drop **		36	34	28	36	35	35	34	28	Kpa	
Heating Capacity ***	Max.	11.460	16.444	18.906	21.357	27.348	34.741	44.455	48.277	W	
	Med.	10.843	15.399	17.660	18.931	23.693	25.033	43.111	46.542	W	
	Min.	10.201	12.736	13.785	16.057	19.367	17.082	39.876	42.652	W	
Water flow rate ***		986	1.414	1.626	1.837	2.352	2.988	3.823	4.152	L/h	
Water pressure drop ***		33	28	26	33	32	33	29	26	Kpa	
N° row coil		3	4	4	4	4	4	4	4	N	
Supply		230/1/50								V-F-Hz	
Air flow rate	Max.	840	1.200	1.260	1.430	1.700	2.400	3.050	3270	m³/h	
	Med.	780	1.016	1.153	1.233	1.436	1.606	2.932	3115	m³/h	
	Min.	724	807	868	1.015	1.130	1.039	2.667	2790	m³/h	
External static pressure	Max.	90	90	90	90	90	90	90	90	Pa	
N° fans		1					2				n°
n° fan speed							3				n°
Power input motor		230	240	290	332	348	652	683	698	W	
Max input current		1,8	1,8	1,8	2,1	2,1	3,7	4,8	4,8	A	
SPL - Sound pressure level	Max.	46	49	50	52	53	55	57	58	dB(A)	
	Med.	42	45	46	47	48	50	52	53	dB(A)	
	Min.	36	38	39	41	41	43	45	45	dB(A)	
Connexions de l'eau		3/4	3/4	3/4	3/4	3/4	3/4	3/4	3/4	"	
Water content		1,11	2,63	3,11	3,34	4,45	4,67	6	7,51	l	
Weight		24	44	47	52	56	66	73	81	kg	

NOTES:

\* Room Air T=27°C D.B. / 19°C W.B. , IN/OUT water 7°/12°C, nominal air flow-rate; For medium and minimum fan speed, water delivery as in maximum speed.

\*\* Room Air T=20°C D.B. , IN/OUT water 70°/60°C, nominal air flow-rate; for medium and minimum fan speed, water delivery as in maximum speed.

\*\* lace with reverberation time of 0.5 seconds.

**Dimensions**

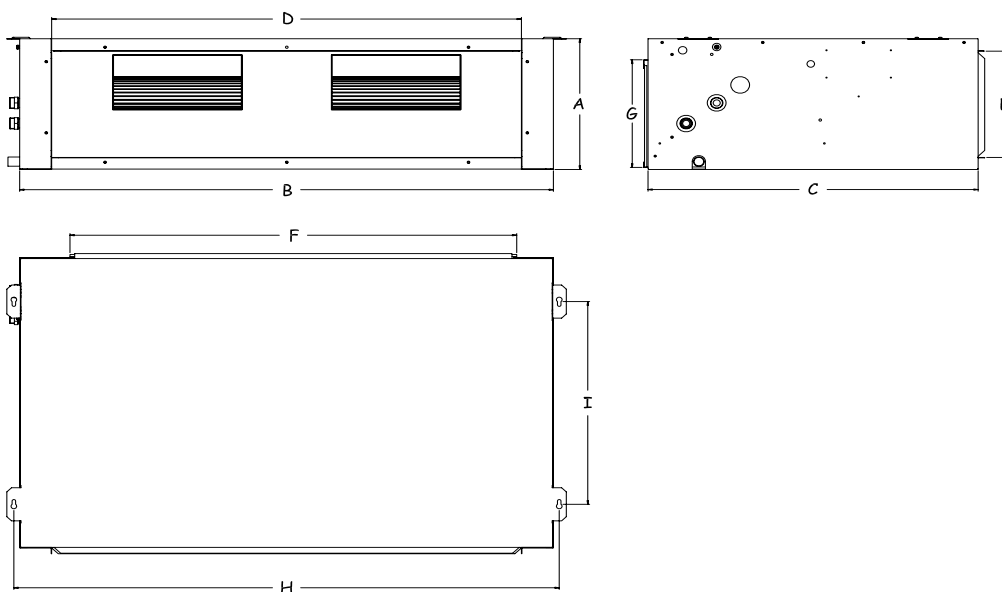

Mod		A	B	C	D	E	F	G	H	I
05	mm	290	640	475	550	235	475	260	665	320
07 - 11	mm	290	1005	650	915	235	950	260	1030	430
13 - 17	mm	315	1135	700	1000	260	950	260	1160	480
19 - 21	mm	360	1330	765	1200	300	1300	320	1355	540
23	mm	360	1635	765	1200	300	1300	320	1660	540

# > TCD

## HIGH HEAD, DOUBLE PANEL DUCTED FAN COIL



### Units Series

#### Unit type

**TCD-H** horizontal unit

**TCD-V** vertical unit

#### Configuration

**2R** with 2-row coil

**4R** with 4-row coil

**6R** with 6-row coil

**4-2R** for 4 pipes system with 4+2-row coil

**6-2R** for 4 pipes system with 6+2-row coil

### Unit specifications

High head, double panel ducted fan coil units, complying with Machine Directive 89/392 EEC and amendments 91/368 EEC, 93/44 EEC, 93/68 EEC, Low-Voltage Directives 72/23 EEC and Electromagnetic Compatibility Directives EMC 89/36 EEC.

Unit terminal for the treatment of room air in the summer season (coil supplied with cold water) and in winter (coil supplied with hot water).

These units are suitable for indoor installation, very compact and amply configurable to meet the requirements of highly qualified designers.

The careful design of the main components, refined styling and the versatility of the product make it suitable for any type of installation in the residential, commercial or industrial context.

Installation therefore only requires the electrical and hydraulic connections.

### Construction characteristics of versions

■ **SUPPORT STRUCTURE:** the frame of the units is in UNI9006/1 Anticorodal 63 extruded aluminium alloy profiles, connected with three-way joints in preloaded nylon and sandwich closure panels, with exposed side in white-grey pre-painted steel and internal side in galvanised steel sheet; unit thermal insulation/soundproofing is obtained through the injection of polyurethane of density not less than 45 kg/m<sup>3</sup>.

■ **AIR FILTER:** easily removed from side, it can be cleaned simply by washing with water, and is G3 efficiency class.

■ **HEAT EXCHANGE COIL:** made with copper pipes arranged in staggered rows to increase heat exchange and aluminium fins, locked by mechanical expansion of the pipes. Complete with water inlet/outlet manifolds.

■ **CONDENSATE TRAY:** in stainless steel sheet, complete with section for connection to the discharge line.

■ **FAN MOTOR:** a directly coupled type, the unit is equipped with dual-intake centrifugal fans and directly coupled three-speed motor with internal thermal protection and startup capacitor always on, with wheel statically and dynamically balanced to minimise noise and vibration. All the electric fans are removable by removing the side panel.

■ **ELECTRICAL CONNECTIONS:** The unit comes complete with protected electrical terminal block for making the connection to the various available adjustment controls.

### Main accessories/Options

Remote [switch](#)

Remote [standard thermostat](#)

Remote [advanced thermostat](#)

[Hot-start](#) consent thermostat

[4XUT system](#)

[Relay Kit](#)

[Air inlet damper](#)

[Inlet plenum](#) for vertical execution

[Inlet grill](#)

[Plenum with 1 damper](#)

[Plenum with 2 damper](#)

[Outlet plenum](#)

[Remote COM3 switch](#)

[Remote PCO thermostat](#)

NB: In case of electrical connection of the unit to Ferroli thermostats, the unit must be fitted with the relay kit accessory (KR).

Model	11	21	31	41	
Air flow rate (max speed)	1150	2100	3100	4100	m <sup>3</sup> /h
External static pressure (Δ)	185	320	330	280	Pa
Sound pressure level (***)	45	55	51	67	dB(A)
Horizontal unit weight TCD-H	97	102	129	168	kg
Vertical unit weight TCD-V	102	106	134	173	kg
<b>Fan</b>					
Power input	240	370	550	550	W
Max input current	2,3	3,5	4,7	4,7	A
n° speed / poles/ Poli	3 / 4	3 / 4	3 / 4	3 / 4	n°
Enclosure protection / Insulation class	20 - B				IP
Power supply	230 / 1 / 50				V / ph / Hz
<b>Filter</b>					
Filter medium pressure drop	G3	G3	G3	G3	classe
<b>TCD 2R</b>					
Heating capacity (**)	8,64	13,8	20,9	27,7	kW
Water flow rate	0,76	1,21	1,84	2,44	m <sup>3</sup> /h
Water pressure drop	9,4	4,5	4,7	9,8	kPa
Air pressure drop	17	27	25	27	Pa
Water connections	1/2"	3/4"	3/4"	1"	Gas
<b>TCD 4R</b>					
<b>Heating mode</b>					
Heating capacity (**)	13,3	21,5	32,9	43,9	kW
Water flow rate	1,17	1,89	2,9	3,86	m <sup>3</sup> /h
Water pressure drop	5,9	3,2	3,6	6,5	kPa
Air pressure drop	35	56	51	55	Pa
<b>Cooling mode</b>					
Cooling capacity total/sensible	6,40 / 4,73	8,54 / 7,25	14,4 / 11,5	20,1 / 15,7	kW
Water flow rate	1,1	1,46	2,47	3,44	m <sup>3</sup> /h
Water pressure drop	7,3	3	3,2	7,3	kPa
Air pressure drop	42	60	60	62	Pa
Water connections	3/4"	1"	1"	1" 1/4	Gas
<b>TCD 6R</b>					
Cooling capacity total/sensible	8,18 / 5,72	13,2 / 9,63	19,2 / 14,2	26,5 / 19,0	kW
Water flow rate	1,4	2,26	3,29	4,54	m <sup>3</sup> /h
Water pressure drop	5,5	4,4	2,6	5,9	kPa
Air pressure drop	49	78	72	83	Pa
Water connections	1"	1" 1/4"	1" 1/4	1" 1/2	Gas

NOTE:

(\*) Cooling capacity Room air 27°C D.B. UR 48% - water IN/OUT 7/12°C - Nominal air flow rate

(\*\*) Heating capacity Room air 20°C D.B. - water IN/OUT 70/60°C - Nominal air flow rate

(\*\*\*) Sound pressure level referred to 1 metre from inlet in free field

## Dimensions

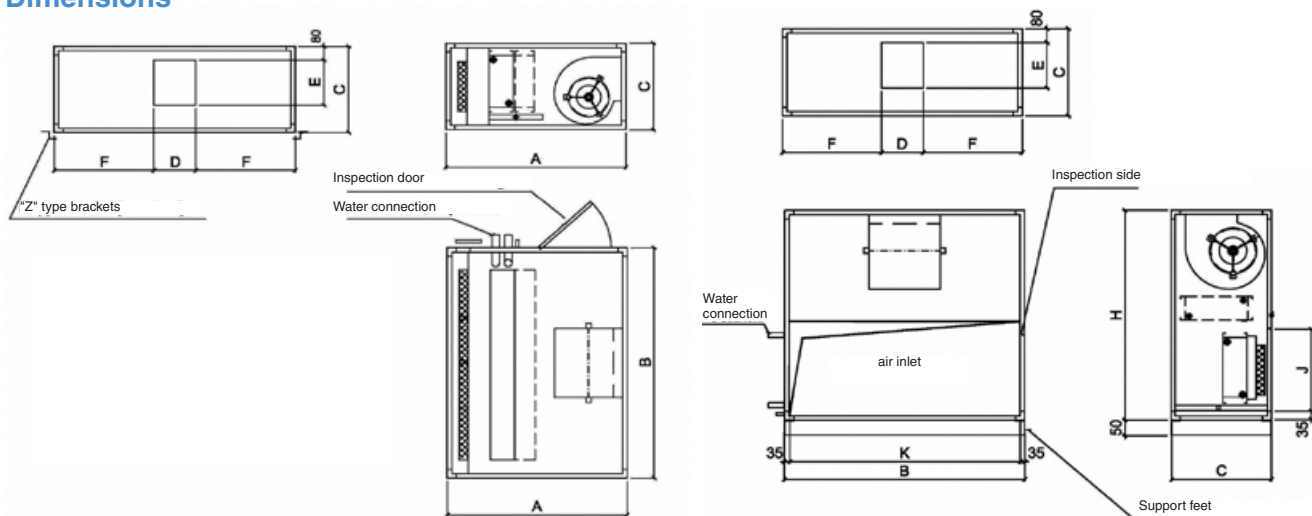

Modell	A	B	C	D	E	F	Model	B	C	D	E	F	H	K	J		
TCD-H 11	mm	1000	850	500	232	261	309	TCD-V 11	mm	850	500	232	261	309	1100	780	430
TCD-H 21	mm	1000	1100	500	232	261	434	TCD-V 21	mm	1100	500	232	261	434	1100	1030	430
TCD-H 31	mm	1100	1350	560	265	289	542	TCD-V 31	mm	1350	560	265	289	542	1200	1280	490
TCD-H 41	mm	1100	1700	560	232	261	320	TCD-V 41	mm	1700	560	232	261	309	1200	1630	490
TCD-H 54	mm	1100	1700	560	265	289	292	TCD-V 54	mm	1700	560	265	289	292	1200	1630	490



# > TCX

## MODULAR HIGH HEAD DUCTED FAN COIL



### Units Series

#### Unit type

**TCX** horizontal unit

#### Configuration

**TCX 2R** only heat with 2-row coil (fig. A)

**TCX 4R** heat and cool with 4-row coil (fig. A)

**TCX 6R** heat and cool with 6-row coil (fig. A)

**TCX 4+2R** 4 pipes systems with 4+2-row coil (fig. B)

**TCX 6+2R** 4 pipes systems with 6+2-row coil (fig. B)

**TCX 6R+S\*** 4 pipes systems with 6+4-row coil (fig. B)

**TCX 4R+S\*** with 4-row coil + drop separator (fig. C)

### Unit specifications

Modular high head ducted fan coil, complying with Machine Directive 89/392 EEC and amendments 91/368 EEC, 93/44 EEC, 93/68 EEC, Low-Voltage Directives 72/23 EEC and Electromagnetic Compatibility Directives EMC 89/36 EEC.

Fan coil unit terminal for the treatment of room air in the summer season (coil supplied with cold water) and in winter (coil supplied with hot water).

These units are suitable for indoor installation, very compact and amply configurable to meet the requirements of highly qualified designers. The careful design of the main components, refined styling and the versatility of the product make it suitable for any type of installation in the residential, commercial or industrial context.

Installation therefore only requires the electrical and hydraulic connections.

#### Construction characteristics of versions

■ **STRUCTURE:** in steel profiles and panels with double shell in prepainted steel sheet, insulated internally with 10 mm thick sound-absorbing material for versions 10 to 40 and 20 mm thick for versions 50 and 60. Inspection and servicing are guaranteed by the door located in the bottom part of the unit.

■ **FILTER:** made with corrugated synthetic septum cells class G3 (ponderal efficiency 85% - EU3).

■ **HEAT EXCHANGER:** copper/aluminium type and copper manifolds.

■ **CONDENSATE TRAY:** in galvanised steel, equipped with a system enabling very easy removal directly from the inspectionable side, without having to disassemble the unit.

■ **FANS:** dual-intake centrifugal and forward wheel blades, statically and dynamically balanced, directly coupled to three-speed single-phase motor and mounted on vibration-mounting hard rubber supports.

■ **ELECTRICAL CONNECTION PANEL:** positioned on the unit, it comes fully wired and complete with relay card for power control of electric fans.

### Main accessories/Options

Remote COM3 switch

Remote PE+PC thermostat

Inlet grill

Air inlet damper

Mixing chamber 2 dampers

Air inlet silencer

Soft pocket filter

Pack humidification thick. 100 mm, complete with water distributor and drip separator

Prearrangement for steam humidification

Water post-heating coil

Electric post-heating coil

Air outlet silencer

Air outlet plenum with circular connections

Air outlet plenum

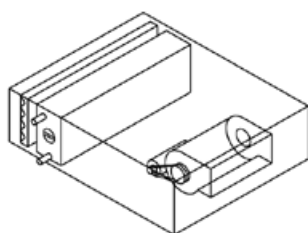

fig. A

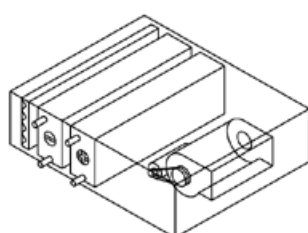

fig. B

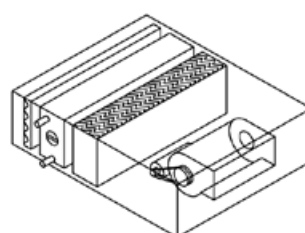

fig. C

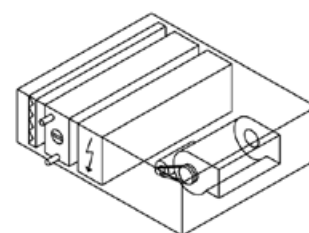

fig. D

	10	20	25	30	40	50	60	
Air flow rate	1040	2150	2740	3360	3950	5070	6450	m³/h
Sound pressure level(****)	51	55	55	57	58	57	59	dB(A)
Power input motor	147	350	700	700	700	840	1260	W
Power supply	230 / 1 / 50							V/ph/Hz
Fan speed / Poles	3/4	3/4	3/4	3/4	3/4	3/4	3/4	
Enclosure protection / Insulation class	20 / B	55 / F	55 / F	55 / F	55 / F	20 / B	20 / B	IP /
<b>TCX 2R</b>	10	20	25	30	40	50	60	
Air flow rate	1040	2150	2740	3360	3950	5070	6450	m³/h
External static pressure	174	183	179	191	188	175	181	Pa
<b>Heating</b>								
Heating Capacity (**)	9,5	18,5	24,2	27,7	33,3	34,9	41,2	kW
<b>TCX 4R</b>	10	20	25	30	40	50	60	
Air flow rate	1040	2150	2740	3360	3950	5070	6450	m³/h
External static pressure	150	150	150	150	150	150	150	Pa
<b>Cooling</b>								
Cooling capacity Total(*)	6,04	12,1	15,7	18,2	21,6	24,1	32,5	kW
Sensible cooling capacity (*)	4,45	8,9	11,6	13,6	16,1	19,7	25,6	kW
<b>Heating</b>								
Heating Capacity (**)	13,8	27,7	35,8	42,5	50,3	58,1	71,3	kW
Heating Capacity (***)	8,04	16,1	20,9	24,6	29,2	33,4	41,5	kW
<b>TCX 6R</b>	10	20	25	30	40	50	60	
Air flow rate	1040	2150	2740	3360	3950	5070	6450	m³/h
External static pressure	125	119	125	115	121	128	123	Pa
<b>Cooling</b>								
Cooling capacity Total(*)	7,08	14,3	18,5	21,9	26,2	34,3	42,1	kW
Sensible cooling capacity (*)	5,04	10,2	13,2	15,7	18,7	24,6	30,6	kW
<b>Heating</b>								
Heating Capacity (**)	14,9	30,5	39,1	47,1	55,7	67	83,3	kW
Heating Capacity (***)	8,85	18	23,2	27,8	33	39,7	49,4	kW

**NOTE:**

- (\*) Cooling capacity Room air 27°C D.B. RH 48% - water IN/OUT 7/12°C - Nominal air flow rate
- (\*\*) Heating capacity Room air 20°C D.B. - water IN/OUT 70/60°C - Nominal air flow rate
- (\*\*\*) Heating capacity Room air 20°C D.B. - water IN/OUT 50°C wtare flow rate like cooling mode - Nominal air flow rate
- (\*\*\*\*) Sound pressure level referred to 1 metre from inlet in free field

**Dimensions**

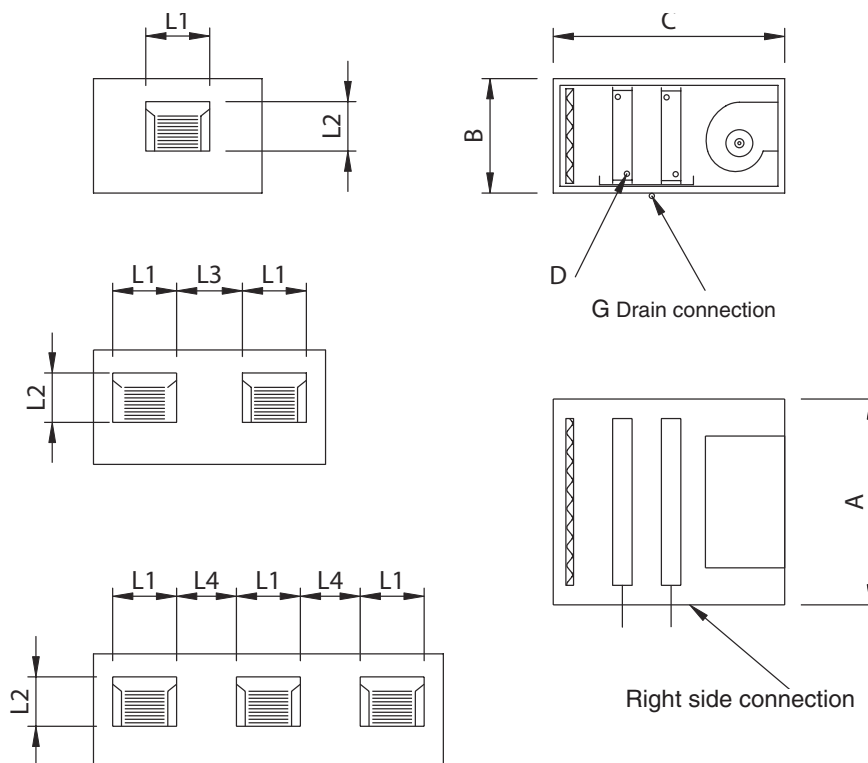

Model	10	20	25	30	40	50	60
<b>A</b>	710	1070	1400	1400	1680	1780	2000
<b>B</b>	390	390	390	390	390	480	480
<b>C</b>	850	850	850	850	850	960	960
<b>D 2 R</b>	3/4"	3/4"	3/4"	3/4"	1"	1"	1"
<b>D 4 R</b>	3/4"	3/4"	1"	1"	1"	1"	1 1/4"
<b>D 6 R</b>	3/4"	1"	1"	1"	1 1/4"	1 1/4"	1 1/4"
<b>G</b>	20	20	20	20	20	20	20
<b>L1</b>	240	306	240	240	306	306	306
<b>L2</b>	216	270	216	270	270	270	270
<b>L3</b>	-	-	400	300	400	435	-
<b>L4</b>	-	-	-	-	-	-	285
<b>N1</b>	670	1030	1360	1360	1640	1720	1940
<b>N2</b>	350	350	350	350	350	420	420



### Units Series

#### Unit type

**TCT-H** horizontal unit

**TCT-V** vertical unit

#### Configuration

**2R** with 2-row coil

**4R** with 4-row coil

**6R** with 6-row coil

**4-2R** 4 pipes systems with 4+2-row coil

**6-2R** 4 pipes systems with 6+2-row coil

### Unit specifications

Large capacity fan coil, complying with Machine Directive 89/392 EEC and amendments 91/368 EEC, 93/44 EEC, 93/68 EEC, Low-Voltage Directives 72/23 EEC and Electromagnetic Compatibility Directives EMC 89/36 EEC.

Fan coil unit terminal for the treatment of room air in the summer season (coil supplied with cold water) and in winter (coil supplied with hot water).

These units are suitable for indoor installation, very compact and amply configurable to meet the requirements of highly qualified designers. The careful design of the main components, refined styling and the versatility of the product make it suitable for any type of installation in commercial or industrial context.

Installation therefore only requires the electrical and hydraulic connections.

#### Construction characteristics of versions

■ **SUPPORT STRUCTURE:** the frame of the units is in UNI9006/1 Anticorodal 63 extruded aluminium alloy profiles, connected with three-way joints in preloaded nylon and sandwich closure panels, with exposed side in white-grey pre-painted steel and internal side in galvanised steel sheet; unit thermal insulation/soundproofing is obtained through the injection of polyurethane of density not less than 45 kg/m<sup>3</sup>.

■ **AIR FILTER:** removable sideways, it can be regenerated simply by washing, and is G3 efficiency class.

■ **HEAT EXCHANGE COIL:** made with copper pipes arranged in staggered rows and with corrugated aluminium finning, locked by mechanical expansion of the pipes. Complete with water inlet/outlet manifolds. The coil holding section provided for on the TCT units is arranged to house heating and/or cooling coils: the section is designed to hold two coils in horizontal and vertical models. The hot water coils are 2-row or 4-row whereas for cooling they can be 4-row or 6-row with chilled water. The standard executions provide for oblique fitting of the cooling coil in vertical models and horizontal fitting of the heating coil, and vertical fitting of both coils in horizontal models.

■ **CONDENSATE TRAY:** in stainless steel sheet, complete with section for connection to the discharge line.

■ **FAN MOTOR:** ventilating section designed to limit fan noise as much as possible. The motor-fan assembly is isolated from the structure by means of suitable shock-absorbers on the base and is complete with neoprene vibration-mounting joint. The centrifugal fans installed are dual-intake with forward blades, statically and dynamically balanced. Coupled-type fans are installed for sizes 100, 130 and 175. Motor-fan coupling is by means of variable-pitch pulleys and V belts for all sizes. Careful selection has enabled high efficiencies to be obtained. The electric motors are 4-pole, externally ventilated and class F isolated with IP55 protection rating, fixed on special guides enabling belt tension adjustment. The use of variable-pitch drive pulleys enables the number of revolutions and therefore the pressure to be adjusted to system requirements.

### Main accessories/Options

Inlet grill

Air inlet damper

Inlet plenum for vertical execution

Plenum with 1 damper

Plenum with 2 dampers

Outlet plenum

UNIT TCT/H - TCT/V	30	50	70	100	130	180	
Air flow (MIN – MAX)	2300-3800	3900-6700	6300-8100	8200-11000	11000-15000	15000-20000	m³/h
Air flow rate nominal	3000	5300	7200	9600	13000	17500	m³/h
Total static pressure (Δ)	150-370	180-350	250-340	250-375	260-350	250-400	Pa
Sound pressure level(*)	58	73	70	68	71	69	dB(A)
Horizontal unit weight TCT-H	197	240	260	360	380	580	kg
Vertical unit weight TCT-V	220	268	290	380	410	550	kg
<b>Fan</b>							
Power input	0,75	1,5	2,2	2,2	4	5,5	kW
N° Fans / Poles	1/4	1/4	1/4	1/4	1/4	1/4	n°
Power supply	400 / 3 / 50						V/ph/Hz
<b>TCT 2R</b>							
Heating Capacity (*)	35,2	53	69,9	95,8	130	178	kW
Water flow rate	3,09	4,66	6,13	8,42	11,3	15,6	m³/h
Water pressure drop	9	4	8	10	12	23	kPa
Air pressure drop	18	32	38	35	35	39	Pa
Water connection	1"1/2	1"1/2	1"1/2	1"1/2	1"1/2	1"1/2	Gas
<b>TCT 4R</b>							
<b>Heating</b>							
Heating Capacity (*)	52,7	84,8	112	153	206	283	kW
Water flow rate	4,63	7,44	9,91	13,4	18,1	24,8	m³/h
Water pressure drop	15	15	27	33	41	45	kPa
Air pressure drop	32	52	57	51	53	58	Pa
<b>Cooling</b>							
Cooling capacity total/sens (**)	31,2 / 17,8	46,5 / 27	62,7 / 36,4	86,9 / 50,5	117 / 68,1	161 / 91,8	kW
Water flow rate	5,2	7,8	10,5	14,5	19,6	26,9	m³/h
Water pressure drop	24	20	35	40	45	80	kPa
Air pressure drop	51	75	90	82	85	86	Pa
Water connection	1" 1/2	1" 1/2	1" 1/2	1" 1/2	1" 1/2	1" 1/2	Gas
<b>TCT 6R</b>							
Cooling capacity total/sens (**)	36,2 / 19,9	60,7 / 34	78,3 / 43,9	108 / 60,6	146 / 81,8	200 / 110	kW
Water flow rate	6	10,1	13,1	18,1	24,4	33,5	m³/h
Water pressure drop	15	42	27	35	44	71	kPa
Air pressure drop	60	90	95	95	96	90	Pa
Water connection	1" 1/2	1" 1/2	1" 1/2	1" 1/2	1" 1/2	2"	Gas

(•) Inlet air 0 °C, water IN/OUT 70/60 °C. max speed air flow.  
 (\*\*) Inlet air 32 °C, RH 50%. water IN/OUT 7/12 °C. max speed air flow.  
 (\*) Referred to the fan: deduct the pressure drop of the selected components in order to get the external static pressure.

(\*\*) Sound pressure level: data referred to 1,5 metres from inlet in free field. The actual operation noise level generally differs from the values shown in the table, depending on operating conditions, reflected noise and surrounding noise.

### Dimensions

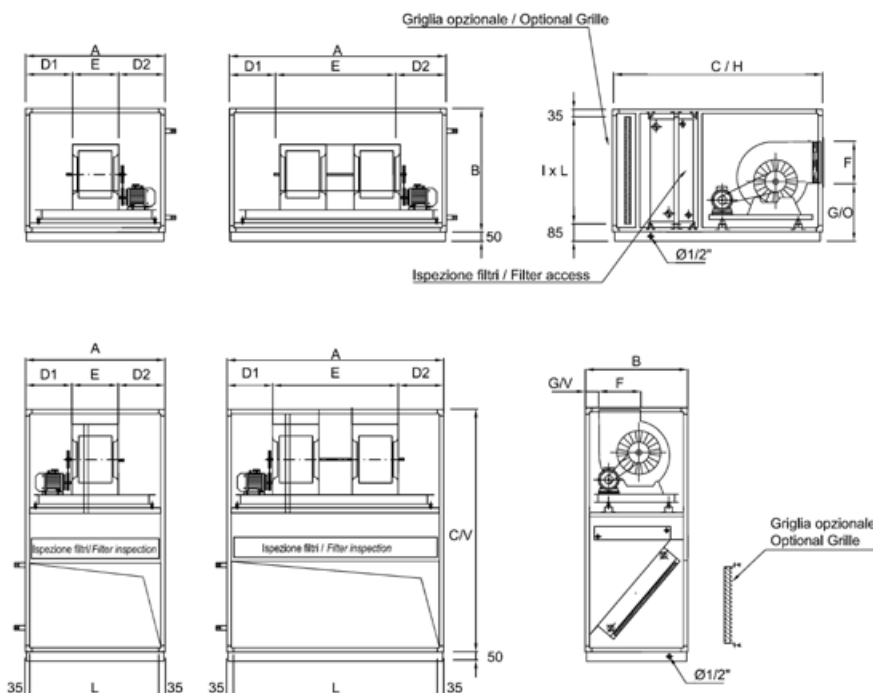

Model	30	50	70	100	130	180
A	mm 1180	1420	1660	1780	1940	2300
B	mm 770	770	770	920	1100	1100
C/H	mm 1290	1290	1290	1290	1290	1290
C/V	mm 1540	1540	1540	1830	2010	2090
D1	mm 418	505	625	222	383	392
D2	mm 418	505	625	428	427	568
E	mm 344	410	410	1130	1130	1340
F	mm 304	354	354	354	354	417
G/H	mm 360	390	390	390	390	410
G/V	mm 150	150	150	105	105	105
I	mm 700	700	700	850	1030	1030
L	mm 1110	1350	1590	1710	1870	2230



The FTP-type handling units represent an important contribution to improving our working environments.

The result of FERROLI's professionalism and many years' experience, they make an important reference point.

The Quality of construction and the components guarantees reliability, functionality and efficiency. Designed to work at low, medium and high pressure, FERROLI FTP units are built with a modular system providing for 18 sizes for a wide range of capacities.

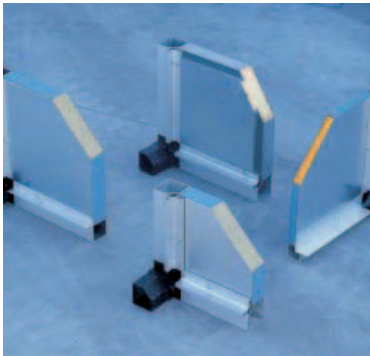

- **STRUCTURE:** Made with strong framework in extruded UNI 9006 anodised aluminium sections, joined with angle joints in die-cast aluminium or nylon panels with double shell and insulated with high density (80-100 kg/m<sup>3</sup>) mineral wool or polyurethane foam with thickness 23 or 50 mm, with normal profiles or a heat barrier. The panels can be:
  - galvanised steel sheet
  - prepainted
  - peraluman
  - AISI 304 stainless steel sheet.

The panels are fixed to the frame with galvanised steel or stainless steel screws and are equipped with self-adhesive type seals. The inspection panels are fitted on hinges and provided with double closing handles (internal and external).

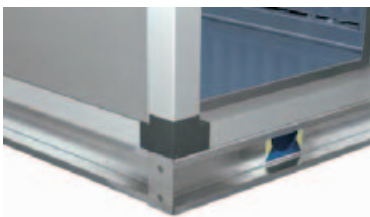

- **BASE:** With a continuous beam in heavy galvanised steel sheet, press bent with sections with a high structural rigidity which ensure safe transport and handling on site.



- **ELECTRIC COILS:** The electric coils have immersion-type heaters with one or more stages, complete with connection panel and safety thermostat.

- **COLLECTION TRAYS:** These can be in galvanised steel or AISI 304 stainless steel sheet, provided with one or more threaded load/discharge manifolds.

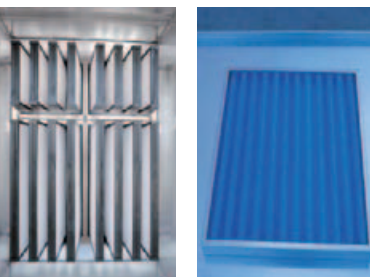

- **AIR FILTERS:** This selection is all-important to ensure the high Quality of the treated air. The types available:
  - roll filters
  - pleated filter cells
  - soft or rigid pocket filters
  - absolute filters
  - activated carbon filters

Efficiency certified in conformity with the main standards (EUROVENT, AFI, ASHRAE, NSB etc.).

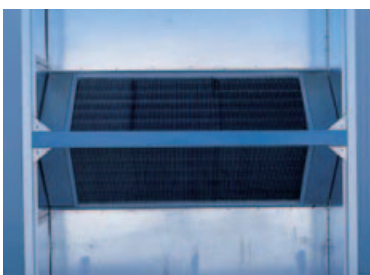

- **RECUPERATOR:** static-type cross flow with sealed aluminium (or stainless steel) plates in order to guarantee no contact between the expelled air and that introduced inside the plant, so as to enable easy servicing. Complete with equalising dampers for creating mixing chambers or bypass for operation with outside air introduction, re-circulation or free-cooling. Rotary type, with rotating drum, are available on request complete with devices for controlling rotation speed.

- **DAMPERS:** As a standard version they have a galvanised sheet frame and extruded aluminium fins, complete with seal, moved by nylon wheels located inside the damper and provided with shaft for applying the servo control. Single dampers for outside air intake, mixing chambers with two dampers and mixing chambers with three dampers can be specified.

## Service

# AIR FTP

The FERROLI design engineers team have prepared the FTP 2010 AIR selection and design software to quickly and easily obtain an operational, construction layout and financial data of the air treatment system.

There is also the selected choice of accessories the printing of the description of the units specifications and a complete technical data sheet.

A sales tool much appreciated by professionals for its easy use and prompt answers.

For further information, contact your local Ferrolì Industrial Climate Control Branch.

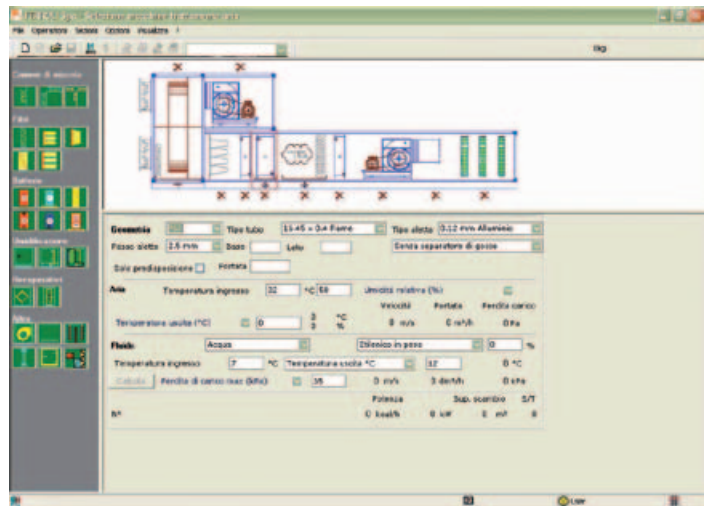

- **HEAT EXCHANGE COILS:** Removable-type for operation with water, mixture with glycol, direct expansion or steam, made with frame in pressed steel sheet, tested at a pressure of 30 Ate. In the standard version they are made with copper pipes and aluminium finned pack, mechanically expanded. Available on request:
  - steel pipe
  - stainless steel pipe
  - copper finned pack
  - tinned copper finned pack.

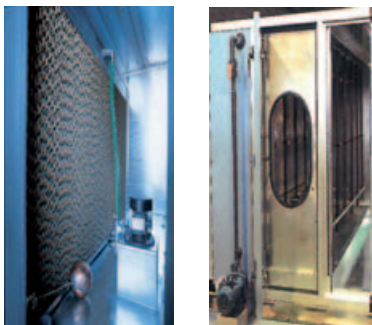

- **HUMIDIFICATION:** Sections for humidification systems are provided for as follows:
  - **WITH STEAM:** created through the installation of an independent steam producer or the assembly of distributors for system steam.
  - **WITH NOZZLES:** commonly called "washer", humidification is created with a system of self-cleaning spray nozzles, fitted on one or two trains. The system provides for a double sealed chamber and can be supplied with expendable water or with a recirculating pump.
  - **WITH PACK:** created with a honeycomb pack in cellulose impregnated with phenolic resins of thickness 100 or 200 mm, complete with metal holding frame and distributor for water in the upper part. It can be with expendable water or with a recirculating pump with filler valve, overflow or bleed-off.



- **FANS:** Dual-intake centrifugal type with forward or backward blades, with the wheel statically and dynamically balanced manufactured to the values required by the specification. They normally use bearings lubricated for a service life of at least 50,000 hours.

- **MOTORS:** Three-phase induction with cage rotor, IP55 protection rating and class F windings. Conforming to Standards IEC 34-1 and IEC 72 (CEI 2 - 3 no. 355 - UNEL 131132-71-B3 UNEL 13118-71); they also meet the national prescriptions (VDE, NFC, NBNC, BS, SEV, NEN, etc.). Mounted on a slide enabling fixing of the drive belt tension. The motor-fan assembly is mounted on hard rubber supports to absorb rotation vibrations.



- **DRIVES:** By means of belts and V pulleys with taper lock bush. All the pulleys, with one or more races, balanced, are in cast iron with galvanic surface treatment. Variable diameter pulleys can be fitted on request.

- **VIBRATION-MOUNTING JOINTS:** They are normally fitted between the fan mouth and the delivery panel, but can also be arranged on all the channel connection flanges; the fabric used is "class 1" self-extinguishing.

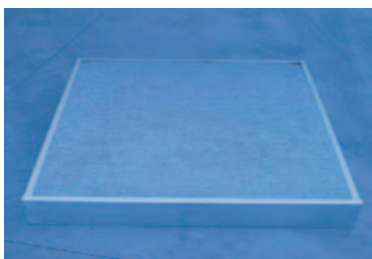

- **SILENCERS:** They can be installed inside or outside the unit located in delivery or intake and are essential for suppressing the noise mainly produced by the fan. Supplied in different lengths of 750 to 2000 mm, they have sound-absorbing septums, made with multiple layers of mineral wool held by a perforated metal sheet; the outer surfaces of the septums (in direct contact with the air) are covered with a glass fibre film to prevent flaking.

# > RFA

## PACKAGED AIR CONDITIONERS AND HEAT PUMPS ROOF TOP FOR OUTDOOR INSTALLATION



### Available range

#### Unit type

PC Heat pump  
(reversible on the refrigerant side)

#### Constructive configurations

VB Base version  
V1 1 damper version  
V2 2 dampers version  
V2 3 dampers version

#### Acoustic setting up

AB Base setting up  
AS Low noise setting up

### Unit description

This series of packaged air conditioners and heat pumps (roof top) satisfies the cooling and heating requirements of medium and large buildings (commercial centres, supermarkets, cinemas, outlets, offices, canteens, restaurants ...)

All the units are suitable for outdoor installation and can be applied to plants realized with various type of air ducts.

Each model is available in various constructive configurations and can be equipped with a large range of accessories in order to fit the different installation requirements.

The region in contact with the treated air, easily accessible, is realized with perfectly washable metal surfaces, externally insulated in order to minimize the thermal losses and to avoid condensate generation both on the internal part and the external part of the structure.

The refrigerant circuit, contained in a compartment protected by the air flow to

simplify the maintenance operations, is equipped with scroll compressors mounted on damper supports. Each compressor is placed on an independent refrigerant circuit in order to keep a constant ratio between the sensible cooling power and total cooling power also at partial loads and to guarantee a better treatment of the air besides a greater reliability.

Each refrigerant circuit is equipped with thermostatic expansion valves, reverse cycle valve, axial fans with safety protection grilles, finned coils made of copper pipes and aluminium louvered fins and high and low pressure switches.

All the units can be equipped with variable speed fans control that allows the units to operate with low outdoor temperatures in cooling and high outdoor temperature in heating and permits to reduce noise emissions in such operating conditions.

The low noise acoustic setting up (AS) is obtained, starting from the base setting up (AB), mounting sound jackets on the compressors and the technical compartment is clad with soundproofing material of suitable thickness.

All the units are supplied with an outdoor temperature sensor, already installed on the unit.

All the units are provided with a phase presence and correct sequence controller device.

All the units are accurately built and individually tested in the factory. Only electric, aerologic and hydraulic connections are required for installation.

### Options

#### Air flow position

- upwards / frontal
- downwards

#### Internal fan

- standard
- upsized
- reduced

#### Heating integration

- hot water coil  
(2 or 3 rows with pipes or 3 way valve)
- electrical heater coil  
(standard or upsized)
- condensing gas heating module  
(standard or upsized)

#### Air flow silencers

#### External fans control

- on-off control
- modulating control (condensation / evaporation control)

#### Enthalpic free cooling

#### Air quality control (CO<sub>2</sub>)

#### Special filters

- rigid pockets filters (F6 - F7 - F8 - F9)
- rigid pocket filters with active carbons

#### Filters differential pressure switch

#### Droplets separator

### Accessories

#### Spring vibration dampers

#### External coils protection grilles

#### High and low pressure gauges

#### Remote thermostat

#### Remote control

#### Modbus serial interface on RS485

#### Programmer clock

#### Phase sequence and voltage controller

#### Roof curb



**NOMINAL performances**

PC	Base setting up (AB)										
	35.1	45.1	55.1	70.2	90.2	110.2	140.2	180.2	220.2		
A35A27	Low noise setting up (AS)										
	Total cooling capacity	35,5	46,3	57,7	71,0	92,3	113	142	184	226	kW
	RST *	0,70	0,70	0,70	0,70	0,70	0,70	0,70	0,70	0,70	-
	Power input	10,9	14,0	17,7	22,5	28,8	36,6	46,6	59,5	73,7	kW
	EER	<b>3,26</b>	<b>3,31</b>	<b>3,26</b>	<b>3,16</b>	<b>3,20</b>	<b>3,09</b>	<b>3,05</b>	<b>3,09</b>	<b>3,07</b>	-
	Air flow rate plant side	6200	8100	10000	11000	14500	17000	22500	29000	35000	m <sup>3</sup> /h
	Available static head plant side	200	200	200	200	200	200	200	200	200	Pa
A7A20	Heating capacity	36,7	47,8	59,5	73,9	95,9	118	148	192	236	kW
	Power input	11,2	14,4	18,2	23,0	29,5	37,5	47,7	60,9	75,5	kW
	COP	<b>3,28</b>	<b>3,32</b>	<b>3,27</b>	<b>3,21</b>	<b>3,25</b>	<b>3,15</b>	<b>3,10</b>	<b>3,15</b>	<b>3,13</b>	-
	Air flow rate plant side	6200	8100	10000	11000	14500	17000	22500	29000	35000	m <sup>3</sup> /h
	Available static head plant side	200	200	200	200	200	200	200	200	200	Pa

Data declared according to EN 14511. The values are referred to units without options and accessories operating with 100% return air.

\* RST = ratio between sensible cooling capacity and total cooling capacity.

A35A27 = source : air in 35°C d.b. / plant : air in 27°C d.b. 19°C w.b.

A7A20 = source : air in 7°C d.b. 6°C w.b. / plant : air in 20°C d.b.

**Acoustic performances**

	Base setting up (AB)										
	35.1	45.1	55.1	70.2	90.2	110.2	140.2	180.2	220.2		
Sound power level	84	85	85	87	87	88	90	92	93		dB(A)
Sound pressure level at 1 metre	67	67	68	69	69	70	71	73	74		dB(A)
Sound pressure level at 5 metres	58	58	59	60	61	61	63	65	66		dB(A)
Sound pressure level at 10 metres	53	53	54	55	56	56	58	60	61		dB(A)
	Low noise setting up (AS)										
	35.1	45.1	55.1	70.2	90.2	110.2	140.2	180.2	220.2		
Sound power level	81	82	82	84	84	85	87	89	90		dB(A)
Sound pressure level at 1 metre	64	64	65	66	66	67	68	70	71		dB(A)
Sound pressure level at 5 metres	55	55	56	58	58	59	60	62	63		dB(A)
Sound pressure level at 10 metres	50	50	51	53	53	54	55	57	58		dB(A)

Performances referred to units with VB constructive configuration (base version) operating in cooling mode at NOMINAL conditions A35A27 with STANDARD air flow rate and available static head.

Unit placed in free field on reflecting surface (directional factor equal to 2) with air inlet and outlet connections ducted for 2 metres.

The sound power level is measured according to ISO 3744 standard.

The sound pressure level is calculated according to ISO 3744 and is referred to a distance of 1/5/10 metres from the external surface of the unit.

OPERATING LIMITS	Unit type	Cooling		Heating		
		min	max	min	max	
Outdoor air inlet temperature	PC	10	50	-10	22	°C
Return air inlet temperature	PC	15	37	5	22	°C

TECHNICAL DATA	35.1	45.1	55.1	70.2	90.2	110.2	140.2	180.2	220.2	
Power supply	400 - 3N - 50	400 - 3N - 50	400 - 3N - 50	400 - 3N - 50	400 - 3N - 50	400 - 3N - 50	400 - 3N - 50	400 - 3N - 50	400 - 3N - 50	V-ph-Hz
Compressor type	scroll	scroll	scroll	scroll	scroll	scroll	scroll	scroll	scroll	-
N° compressors / N° refrigerant circuits	1 / 1	1 / 1	1 / 1	2 / 2	2 / 2	2 / 2	2 / 2	2 / 2	2 / 2	n°
Plant side heat exchanger type	finned coil	finned coil	finned coil	finned coil	finned coil	finned coil	finned coil	finned coil	finned coil	-
Source side heat exchanger type	finned coil	finned coil	finned coil	finned coil	finned coil	finned coil	finned coil	finned coil	finned coil	-
External fans type	axial	axial	axial	axial	axial	axial	axial	axial	axial	-
N° external fans	2	2	2	4	4	4	4	4	4	n°
Internal fans type	centrifugal	centrifugal	centrifugal	centrifugal	centrifugal	centrifugal	centrifugal	centrifugal	centrifugal	-
N° internal fans	2	2	2	2	2	2	2	2	2	n°

HEATING INTEGRATION		35.1	45.1	55.1	70.2	90.2	110.2	140.2	180.2	220.2	
Electrical heater coil	standard	9,0	9,0	9,0	18,0	18,0	18,0	36,0	36,0	36,0	kW
	upsized	18,0	18,0	18,0	31,5	31,5	31,5	63,0	63,0	63,0	kW
Condensing gas heating module	standard	44,8	44,8	44,8	93,4	93,4	93,4	186,8	186,8	186,8	kw
	upsized	54,0	54,0	54,0	145,0	145,0	145,0	290,0	290,0	290,0	kW



## CONSTRUCTIVE CONFIGURATIONS

Each model can be supplied in different constructive configurations in order to satisfy the application requirements that can be necessary for the plants. The various versions, obtained adding to the base version some modules, are always supplied already assembled, wired and tested in the factory. All the versions can be arranged with standard air flow position (frontal for the models of frame 1 and 2 and upwards for the models of frame 3) or with downwards air flow position. The dotted components are accessories.

### VB - Base version

It only allows to operate with all return air. It contains the standard filtering section and the air-refrigerant exchange coil that allows the heating, cooling and dehumidification processes to be performed.

It is possible to add a further heating section (hot water coil or electrical heater coil) and the droplets separator. Instead of such heating section it is possible to add a gas heating module, placed between the filtering section and the air-refrigerant exchange coil.

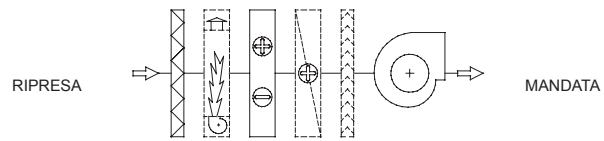

### V1 - 1 damper version

It allows to operate with a percentage of outdoor fresh air, adjustable manually setting the damper placed on the adding module. The outdoor air inlet is equipped with a rain protection cap and a metal safety grille. The expulsion from the conditioned ambient of an air flow rate equal to the outdoor fresh air flow rate must be realized independently from the unit by means of overpressure openings or other extraction devices.

In the adding module can be placed various type of special filters in order to complete the standard filtering section.

Also in this version it is possible to add a further heating section (hot water coil or electrical heater coil) and the droplets separator.

Instead of such heating section it is possible to add a gas heating module, placed between the filtering section and the air-refrigerant exchange coil.

Downstream the internal fans, air flow silencers can be installed to reduce the noise transmitted to the conditioned ambients through the air ducts (only for the models of frame 1 and 2).

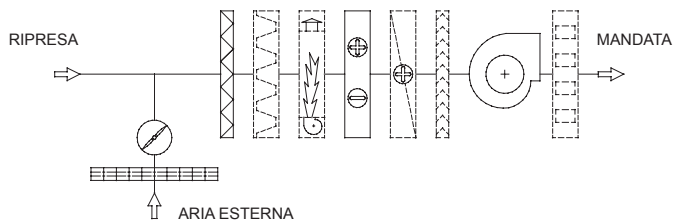

### V2 - 2 dampers version

The presence of two motorized dampers managed by the controller of the unit allows to operate with a minimum percentage of outdoor fresh air (adjustable through the user interface) and to perform thermal free cooling.

The outdoor air inlet, equipped with a rain protection cap and a metal safety grille, is designed for 100% of the total air flow rate and allows to operate in free cooling with all outdoor air.

The expulsion from the conditioned ambient of an air flow rate equal to the outdoor fresh air flow rate must be realized independently from the unit by means of overpressure openings or other extraction devices.

In the adding module can be placed various type of special filters in order to complete the standard filtering section.

It is possible to add a further heating section (hot water coil or electrical heater coil) and the droplets separator. Instead of such heating section it is possible to add a gas heating module, placed between the filtering section and the air-refrigerant exchange coil.

It is also possible to perform enthalpic free cooling by means of the installation of the humidity sensors. Downstream the internal fans, air flow silencers can be installed to reduce the noise transmitted to the conditioned ambients through the air ducts (only for the models of frame 1 and 2).

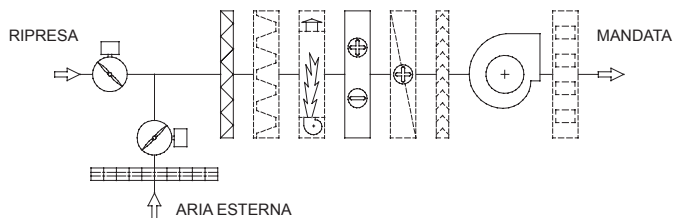

### V3 - 3 dampers version

The presence of three motorized dampers managed by the controller of the unit allows to operate with a minimum percentage of outdoor fresh air (adjustable through the user interface), to perform thermal free cooling and to manage the air expulsion.

The outdoor air inlet, equipped with a rain protection cap and a metal safety grille, is designed for 100% of the total air flow rate and allows to operate in free cooling with all outdoor air.

The expulsion from the conditioned ambient of an air flow rate equal to the outdoor fresh air flow rate is realized through the return air fan and the expulsion damper placed inside the unit.

In the adding module can be placed various type of special filters in order to complete the standard filtering section.

Also in this version it is possible to add a further heating section (hot water coil or electrical heater coil) and the droplets separator. Instead of such heating section it is possible to add a gas heating module, placed between the filtering section and the air-refrigerant exchange coil. It is also possible to perform enthalpic free cooling by means of the installation of the humidity sensors.

Downstream the internal fans, air flow silencers can be installed to reduce the noise transmitted to the conditioned ambients through the air ducts (only for the models of frame 1 and 2).

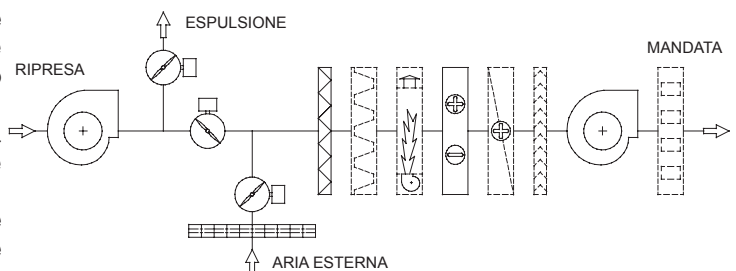

### CONTROL SYSTEM

The unit is managed by a microprocessor controller to which, through a board placed inside the electrical panel, all the electrical loads and the control devices are connected. The user interface, accessible removing the protection panel of the electrical board, is realized by a display and two buttons that allow to view and, if necessary, modify all the operating parameters of the unit.

Are available, as accessories, a remote control, that reports all the functionalities of the user interface placed on the unit, or a remote thermostat.

The main functions available are :

- treated air temperature management (through set point adjustment)
- treated air humidity management (only with enthalpic free cooling option)
- treated air quality management (CO<sub>2</sub>)
- thermal or enthalpic (option) free cooling
- external fan management by means of continuous rotational speed control (option)
- internal fan management
- return air fan management

- integrative heating sources management (electrical heater coil, hot water coil, gas heating module)
- defrost cycle management
- dampers management (outdoor air, return air and expulsion air)
- compressor and internal fan operating hours recording
- serial communication through Modbus protocol
- remote on-off
- remote cooling-heating
- active alarms visualization
- general alarm digital output



### DIMENSIONS AND MINIMUM OPERATING AREA

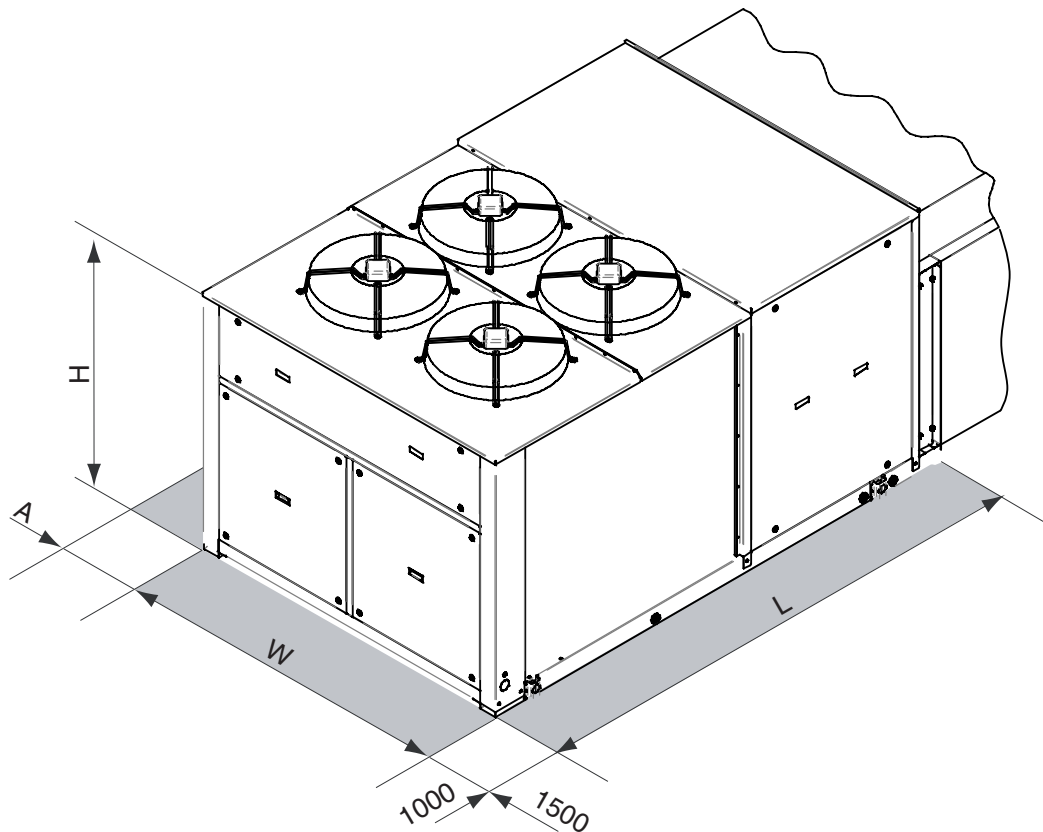

	35.1	45.1	55.1	70.2	90.2	110.2	140.2	180.2	220.2		
L	VB	2900	2900	2900	3100	3100	3100	3900	3900	3900	mm
	VB with gas heating module	3830	3830	3830	4300	4300	4300	5100	5100	5100	mm
	V1 e V2	4000	4000	4000	4200	4200	4200	5000	5000	5000	mm
	V1 e V2 with gas heating module	4930	4930	4930	5400	5400	5400	6200	6200	6200	mm
	V3	4800	4800	4800	5000	5000	5000	6600	6600	6600	mm
	V3 with gas heating module	5730	5730	5730	6200	6200	6200	7800	7800	7800	mm
W	1400	1400	1400	2000	2000	2000	2200	2200	2200	mm	
H	1600	1600	1600	1600	1600	1600	2350	2350	2350	mm	
A	1000	1000	1000	1500	1500	1500	1500	1500	1500	mm	

# > Main specification of heat recovery terminal units

UT REC / UT REC C

UT REC R

UT REC DP / UT REC DP F

RECOVERY EFFICIENCY IN WINTER MODE

RECOVERY EFFICIENCY IN SUMMER MODE

FERROLI offers a complete range of heat recovery terminal units, to meet all system requirements.

## > UT REC

available in two versions:

**UT REC** with static heat recuperator in ALUMINIUM; enables recovery of the sensible heat otherwise lost.

**UT REC C** with PAPER PACK static heat recuperator: in special treated self-extinguishing stiff paper. The structure consists of a pair of sheets with an interposed corrugated third sheet separating these and creating a triangular air channel (drawing opposite). The paper sheets are permeable to steam, enabling recovery of the sensible as well as latent heat. In this way limited air side pressure losses are obtained, as well as a high exchange area and therefore higher recovery are achieved to values higher than 55-60%.

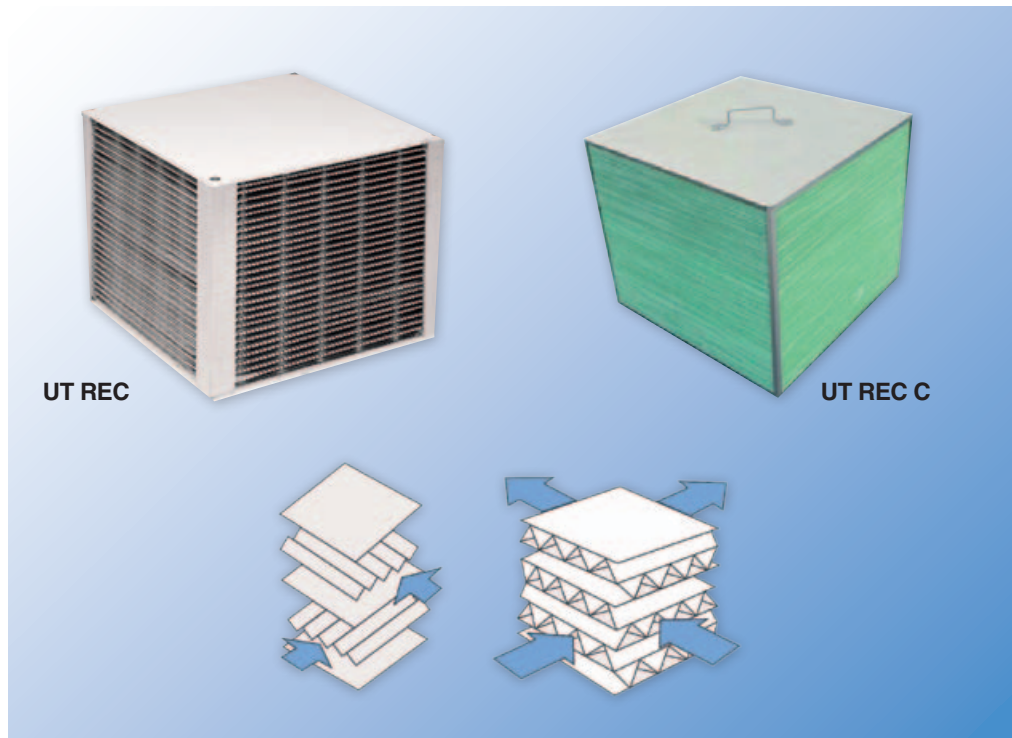

## > UT REC R

Available with a high efficiency rotary-type heat recuperator.

Made in aluminium with a hygroscopic surface.

Exchange efficiency is guaranteed by the quality of the seals that isolate the two air flows.

The rotor consists of alternate flat and corrugated aluminium sheets wrapped around each other.

This creates a "honeycomb" structure in whose channels the two air flows run in an opposed direction.

The surface, made porous by special treatments, allows the humidity to be absorbed, enabling recovery of the sensible and latent heat of the expelled air, resulting in recovery efficiency values above 85-90%.

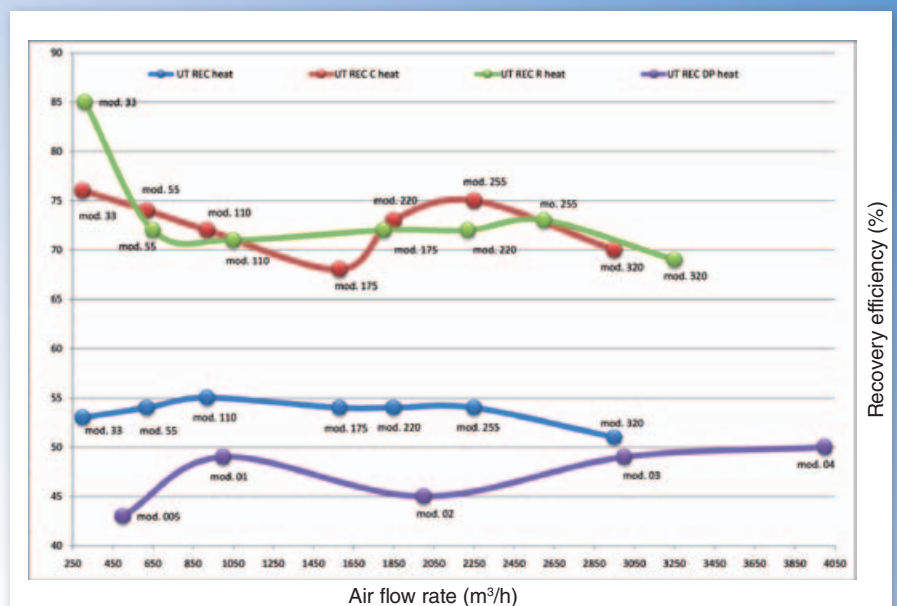

# >>> INDUSTRIAL AIR-CONDITIONING <<<



## > UT REC DP and DP F

Available with static-type heat recuperator in ALUMINIUM enabling recovery of the sensible heat otherwise lost. These units have a structure that enables outdoor installation, after application of a covering and suitable positioning.

The **UT REC DP** range features compact sizes < and the available accessories include a 2-row exchanger for heating only (acc. fitted).

The **UT REC DP F** range comes complete with a 4-row exchanger for cooling the air coming out the recovery exchanger. It therefore has larger dimensions than the previous version to enable lower speeds through the coil.

**NB:** The unit is designed to integrate the room air and ensure its change in a system. Cooling only, and not conditioning, is guaranteed.

## > RECOVERY EFFICIENCY IN WINTER MODE

The graphs clearly show how recovery efficiency varies according to the period of operation and even of the type of recuperator.

Graph A shows how recovery efficiency increases according to the type of exchanger.

Reference conditions:  
Outside Air T= - 5°C 80% R.H.  
Room air T= 20°C 50% R.H.  
max. speed.

## > RECOVERY EFFICIENCY IN SUMMER MODE

In particular, Graph B shows how rotary heat recovery exchangers and paper pack heat recovery exchangers make an important contribution to energy-saving even in summer mode and therefore all year.

Reference conditions:  
Outside Air T= 32°C 50% R.H.  
Room air T= 26°C 50% R.H.  
max. speed.

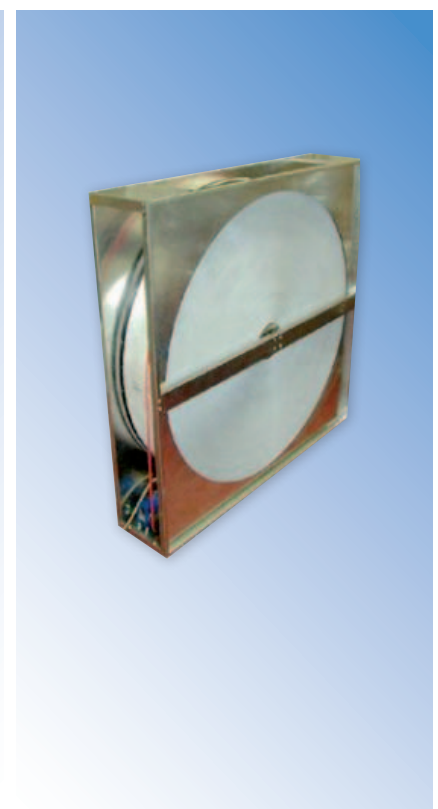
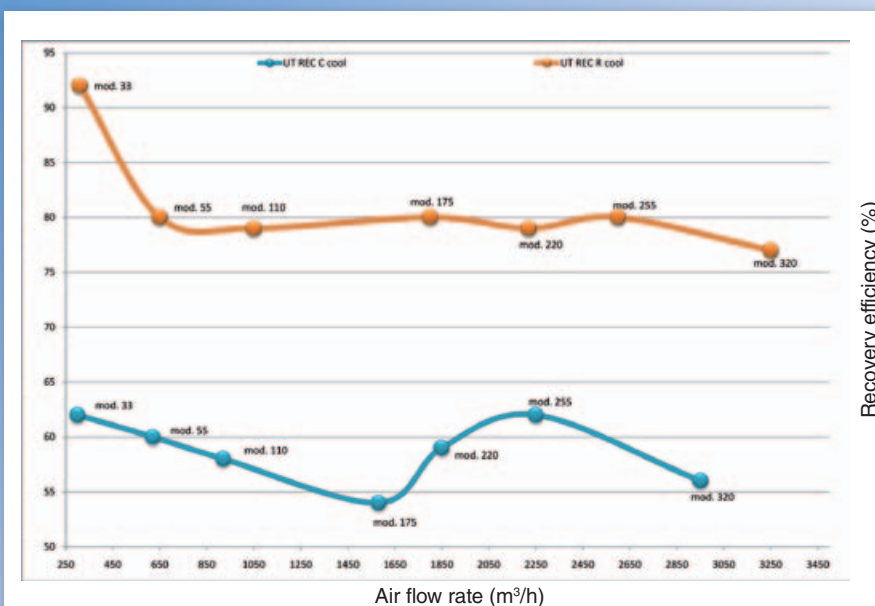



# > UT REC

## SINGLE-PANEL HEAT RECOVERY UNITS



### Units Series

#### Unit type

- UT REC** with recuperator in aluminium
- UT REC C** with paper pack recuperator

### Unit specifications

- STRUCTURE:** in strong aluzink sheet, lined with a suitable thickness of polyethylene and polyester to prevent heat loss, condensation and for increased soundproofing.
- CONDENSATE TRAY:** in ABS, it is placed under the recuperator to collect condensate during summer and winter operation.
- AIR FILTER:** situated inside the unit, it is easily removed from side and made from recyclable materials, cleanable by washing.
- FAN MOTOR:** a directly coupled type, the unit is equipped with a three-speed motor/fan assembly (single-speed for models 33 and 55) with internal thermal protection and startup capacitor always on, with wheel statically and dynamically balanced to reduce noise and vibration.

- ELECTRIC BOARD:** situated on the unit, it consists of a relay power board to facilitate electrical connections and the control of fans with possible remote controls (not present for models 33 and 55).

#### HEAT RECUPERATOR:



**ALUMINIUM:** static-type, it only enables recovery of the sensible heat otherwise lost (picture below).

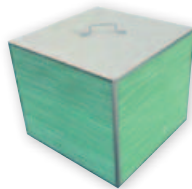

**WITH PAPER PACK:** Static-type, it enables recovery of the sensible heat and latent heat. In this way a high efficiency is obtained.

### Main accessories/Options

- Servo motor for damper motorisation
- Pressure switch for dirty filter signalling
- Antifreeze thermostat
- Hot water post-heating coil providing for the use of a 2-row coil.
- External section with 3-row water coil for heating or cooling
- Equalising damper with fins, arranged for servo control.
- 1-stage electric post-heating section.
- Remote COM3 switch
- Remote PE+PC thermostat
- Single-phase speed variator

### CONFIGURATION

Depending on the configuration of the plant duct are available four possible configuration of recovery.

CONFIGURATION 01

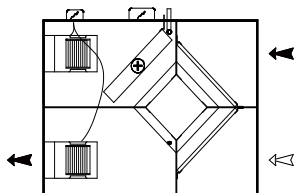

CONFIGURATION 02

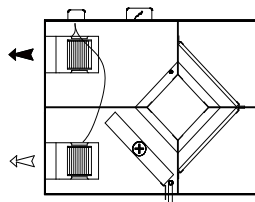

CONFIGURATION 03

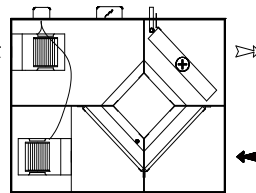

CONFIGURATION 04

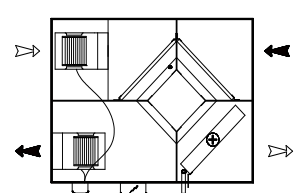

Supply fan	33	55	110	175	220	255	320	410	
Power supply	230 / 1 / 50								400 / 3 / 50 V/ph/Hz
Air flow rate	300	620	920	1580	1850	2250	2950	3920	m³/h
External static pressure	45	55	65	70	77	80	100	100	Pa
Sound pressure level 1,5m	40	48	47	46	50	48	50	54	dB(A)
max. input current	0,75	1,8	2,2	4,4	4,8	5,2	8,3	5	A
n° speed	3	3	3	3	3	3	3	1	n°
Performance UT-REC	33	55	110	175	220	255	320	410	
Recovery type/ Recuperator	cross flow and static / Aluminum plate exchanger								
<b>Winter</b>									
P.A.I. (Room air)	20	20	20	20	20	20	20	20	°C
P.A.E. (Ambient air)	-5/80	-5/80	-5/80	-5/80	-5/80	-5/80	-5/80	-5/80	°C/%
MAND (Fresh air)	8,3	8,5	8,8	8,15	8,5	8,5	7,8	9,3	°C
REC (Heating recovery capacity)	1,50	3,10	4,70	7,90	9,20	11,2	13,9	20,6	kW
Efficiency recovery (sensible/latent)	53	54	55	54	54	54	51	57	%
Performance UT-REC C	33	55	110	175	220	255	320	410	
Recovery type/ Recuperator	cross flow and static / hygroscopic paper pack								
<b>Winter</b>									
P.A.I. (Room air)	20 / 50	20 / 50	20 / 50	20 / 50	20 / 50	20 / 50	20 / 50	20 / 50	°C
P.A.E. (Ambient air)	-5/80	-5/80	-5/80	-5/80	-5/80	-5/80	-5/80	-5/80	°C
MAND (Fresh air)	14,0/39,5	13,5/39,7	13,0/36,7	12,0/42,0	13,3/49,4	13,8/48,8	12,5/50,2	11,0/47,6	°C/%
REC (Heating recovery capacity)	2,60	5,20	7,20	12,2	16,9	21,1	25,6	30,8	kW
Efficiency recovery (sensible/latent)	76/62	74/60	72/56	68/55	73/65	75/67	70/62	66/56	%
<b>Summer</b>									
P.A.I. (Room air)	26 / 50	26 / 50	26 / 50	26 / 50	26 / 50	26 / 50	26 / 50	26 / 50	°C/%
P.A.E. (Ambient air)	32 / 50	32 / 50	32 / 50	32 / 50	32 / 50	32 / 50	32 / 50	32 / 50	°C/%
MAND (Fresh air)	28,3/51,2	28,4/51,2	28,5/51,5	28,8/50,8	28,5/50,5	28,3/50,5	28,6/51,0	28,9/50,9	°C/%
REC (Heating recovery capacity)	1	2	2,9	4,7	6,1	7,9	9,1	11,3	kW
Efficiency recovery (sensible/latent)	62/60	60/58	58/55	54/53	59/59	62/62	56/55	52/51	%
<b>Accessories</b>									
BW	33	55	110	175	220	255	320	410	
Coil type	N.A.		Cu/Al						
n° rows			2	2	2	2	2	2	n°
Coil connection			3/4"	3/4"	3/4"	3/4"	3/4"	3/4"	"
<b>Winter</b>									
Inlet/outlet air temperature			8,0 / 33,4	8,0 / 30,8	8,0 / 30,2	8,0 / 33,2	8,0 / 31,3	8,0 / 29,7	°C
Water temperature IN/OUT			70 / 60	70 / 60	70 / 60	70 / 60	70 / 60	70 / 60	°C
Heating capacity			8,2	12,2	14,4	20,3	24,2	29,9	kW
Air pressure drop			25	32	35	24	36	36	Pa
BFW	33	55	110	175	220	255	320	410	
Coil type	N.A.		Cu/Al						
n° rows			3	3	3	3	3	3	n°
Coil connection			3/4"	3/4"	3/4"	3/4"	3/4"	3/4"	"
<b>Winter</b>									
Inlet/outlet air temperature			8,0 / 45	8,0 / 43,4	8,0 / 45	8,0 / 46,5	8,0 / 43,7	8,0 / 41,5	°C
Water temperature IN/OUT			70 / 60	70 / 60	70 / 60	70 / 60	70 / 60	70 / 60	°C
Heating capacity			12	19,6	23,7	30,5	37	46,2	kW
Air pressure drop			28	41	39	27	40	53	Pa
<b>Summer</b>									
Inlet air / UR			30 / 50	30 / 50	30 / 50	30 / 50	30 / 50	30 / 50	°C / %
Outlet air temperature			19,2	18,9	18,2	17,3	18,3	19,1	°C
Water temperature IN/OUT			7 / 12	7 / 12	7 / 12	7 / 12	7 / 12	7 / 12	°C
Cooling capacity total/sensible			5/3,3	8,8/5,8	11,1/7,2	14,7/9,4	17,4/11,4	20,9/13,9	kW
Air pressure drop			38	50	53	45	48	60	Pa

**Dimensions**

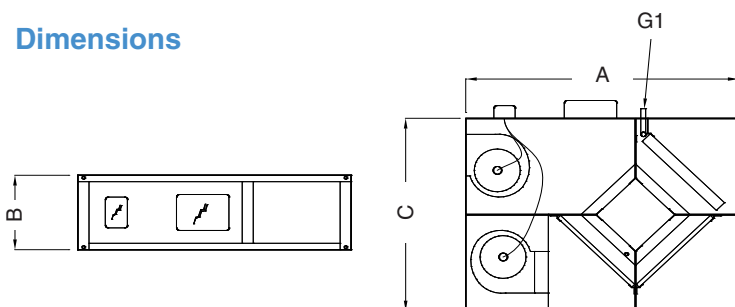

Mod.	33	55	110	175	220	255	320	400	
A	990	990	1140	1300	1380	1650	1650	1750	mm
B	290	290	410	500	500	600	600	600	mm
C	750	750	860	860	960	1230	1230	1230	mm
G1 BW			3/4"	3/4"	3/4"	3/4"	3/4"	3/4"	"
Connection BFW			3/4"	3/4"	3/4"	3/4"	3/4"	3/4"	"

# > UT REC R

## SINGLE PANEL ROTARY HEAT RECOVERY UNITS



### Units Series

Unit type

**UT REC R** Horizontal unit

### Unit specifications

- **STRUCTURE:** in strong aluzink sheet, lined with polyethylene and polyester sheets of 20 mm average thickness to prevent heat loss, condensation and for increased soundproofing.
- **HEAT RECUPERATOR:** high-efficiency rotary type, enabling recovery of the sensible and latent heat of the expelled air. Complete with condensate tray.
- **AIR FILTER:** situated inside the unit, it is easily removed from side and made from recyclable materials, cleanable by washing (efficiency EU3).

- **FAN MOTOR:** a directly coupled type, the unit is equipped with a three-speed fan/motor assembly with internal thermal protection and startup capacitor always on, with wheel statically and dynamically balanced to minimise noise and vibration.
- **ELECTRIC BOARD:** situated on the unit, it consists of a relay power board to facilitate electrical connections and the control of fans and wheel motor with remote controls.

### Main accessories/Options

- Servo motor for damper motorisation
- Pressure switch for dirty filter signalling
- Antifreeze thermostat
- Hot water post-heating coil providing for the use of a 2-row coil.
- External section with 3-row water coil for heating or cooling
- Equalising damper with fins, arranged for servo control.
- 1-stage electric post-heating section.
- Remote COM3 switch
- Remote PE+PC thermostat
- Single-phase speed variator

### CONFIGURATION

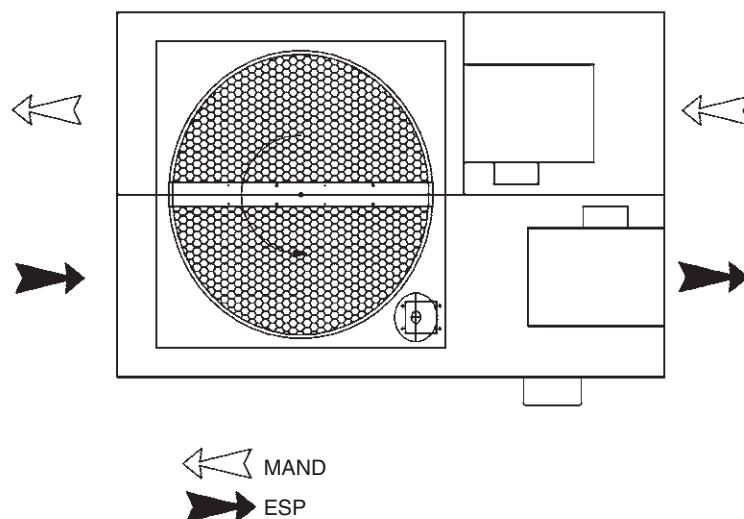

Supply fan	33	55	110	175	220	255	320	410	
Power supply	230 / 1 / 50							400 / 3 / 50	V/ph/Hz
Air flow rate	310	650	1050	1800	2220	2600	3250	4290	m³/h
External static pressure	50	65	80	130	100	110	125	130	Pa
Sound pressure level 1,5m	40	48	47	46	50	48	50	54	dB(A)
Motor input power	92	170	147	350	350	350	550	750	W
max. input current	1	2	2,5	4,8	5,2	5,6	8,7	5,4	A
n° speed / Poles	1/4	1/4	3/4	3/4	3/4	3/4	3/4	2/4	n°
Enclosure protection / Insulation class	44 / F	44 / F	44 / F	44 / F	44 / F	55 / F	44 / F	55 / F	IP

Performance UT-REC R	33	55	110	175	220	255	320	410	
Recovery type/ Recuperator	Hentalpic rotary / Aluminium hygroscopic								

**Winter**

P.A.I. (Room air)	20 / 50	20 / 50	20 / 50	20 / 50	20 / 50	20 / 50	20 / 50	20 / 50	°C/%
P.A.E. (Ambient air)	-5/80	-5/80	-5/80	-5/80	-5/80	-5/80	-5/80	-5/80	°C/%
MAND (Fresh air)	16,3 / 52,5	13 / 57,6	12,7 / 58,5	13 / 57,6	13,0 / 58,3	13,1 / 57,2	12,3 / 60,5	10,8/67,4	°C/%
REC (Heating recovery capacity)	3,6	6,3	10	17,4	21,5	25,2	30,5	37,8	kW
Efficiency recovery (sensible/latent)	85/82	72/69	71/68	72/69	72/69	73/69	69/67	63/63	%

**Summer**

P.A.I. (Room air)	26 / 50	26 / 50	26 / 50	26 / 50	26 / 50	26 / 50	26 / 50	26 / 50	°C/%
P.A.E. (Ambient air)	32 / 50	32 / 50	32 / 50	32 / 50	32 / 50	32 / 50	32 / 50	32 / 50	°C/%
MAND (Fresh air)	26,5 / 56,0	27,2 / 53,7	27,3 / 53,4	27,2 / 53,7	27,3 / 53,4	27,2 / 53,7	27,4 / 53,1	27,8/51,9	°C/%
REC (Heating recovery capacity)	1,3	2,5	4	6,9	8,6	10	12,4	15,7	kW
Efficiency recovery (sensible/latent)	92/73	80/69	79/69	80/69	79/69	80/69	77/68	70/66	%

**Accessories**

BFW	33	55	110	175	220	255	320	410	
Coil type	N.A.		Cu/Al						
n° rows			3	3	3	3	3	3	n°
Coil connection			3/4"	3/4"	3/4"	3/4"	3/4"	3/4"	"

**Winter**

Inlet/outlet air temperature			12 / 45,2	12 / 43,2	12 / 43,8	12 / 46,5	12 / 43,9	12 / 42,4	°C
Water temperature IN/OUT			70 / 60	70 / 60	70 / 60	70 / 60	70 / 60	70 / 60	°C
Heating capacity			10,8	19,2	22,9	30,8	38,1	45,4	kW
Air pressure drop			28	41	39	27	40	53	Pa

**Summer**

Inlet air / UR			30 / 50	30 / 50	30 / 50	30 / 50	30 / 50	30 / 50	°C / %
Outlet air temperature			19,2	19,3	18,9	17,9	18,8	18,8	°C
Water temperature IN/OUT			7 / 12	7 / 12	7 / 12	7 / 12	7 / 12	7 / 12	°C
Cooling capacity total			4,7	9,8	12,2	15,7	20,5	22,1	kW
Cooling capacity sensible			3,3	6,5	8	10,2	13,3	14,7	kW
Air pressure drop			38	50	53	45	48	60	Pa

BE-R	33	55	110	175	220	255	320	410	
Power supply	230 - 1 - 50				400 - 3 - 50				V-ph-Hz
Power input	1,5	3	3	6	6	12	12	12	kW
n° steps	1	1	1	1	1	1	1	1	n°
Inlet air temperature	12	12	12	12	12	12	12	12	°C
Outlet air temperature	26,2	26,4	21,6	29,5	20,6	26,4	22,4	20,4	°C

**Dimensions**

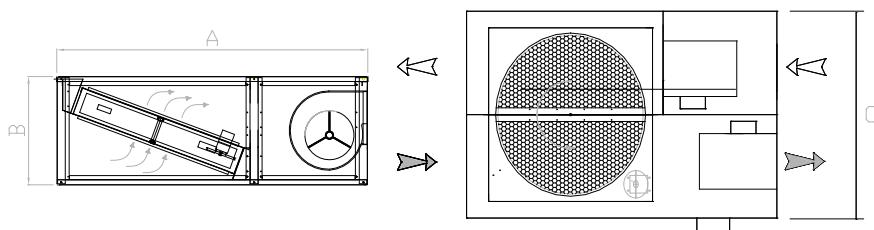

Mod.	33	55	110	175	220	255	320	400	
A	1075	1075	1205	1400	1540	1720	1720	1720	mm
B	425	425	460	530	560	600	600	600	mm
C	750	750	860	860	960	1230	1230	1230	mm
G1 BW			3/4"	3/4"	3/4"	3/4"	3/4"	3/4"	"
Connection BFW			3/4"	3/4"	3/4"	3/4"	3/4"	3/4"	"



# > UT REC DP

## DOUBLE PANEL HEAT RECOVERY UNITS



### Units Series

Unit type

**UT-REC DP H**    **Horizontal unit**  
**UT-REC DP V**    **vertical unit**

### Unit specifications

■ **SUPPORT STRUCTURE:** in strong extruded aluminium profiles and double panel in galvanised steel sheet inside and prepainted galvanised sheet steel outside, with thermal insulation and soundproofing in hot-injected polyurethane foam, thick. 23 mm.

- **HEAT RECUPERATOR:** static-type in aluminium enabling recovery of the heat otherwise lost. Efficiency is guaranteed by the quality of the insulation.
- **CONDENSATE TRAY:** in sheet steel, it is placed under the recuperator for the condensate in summer mode.
- **AIR FILTER:** made with pleated filter cells, class G4 (ponderal eff. 90.1%), metal frame and electrowelded screen, easily removed from side.
- **FAN MOTOR:** a directly coupled type, three-speed with internal thermal protection and startup capacitor always on, with wheel statically and dynamically balanced to minimise noise and vibration.

### Main accessories/Options

- Hot water post-heating coil providing for the use of a 2-row coil.
- 1-stage electric post-heating section.
- Safety microswitch
- Speed selector CV3
- Protection roof

### Layout

Unit are available in horizontal and vertical layout

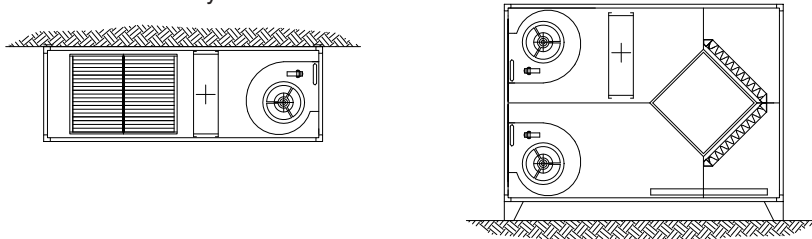

### Configuration

Depending on the configuration of the plant duct are available six possible configuration of recovery.

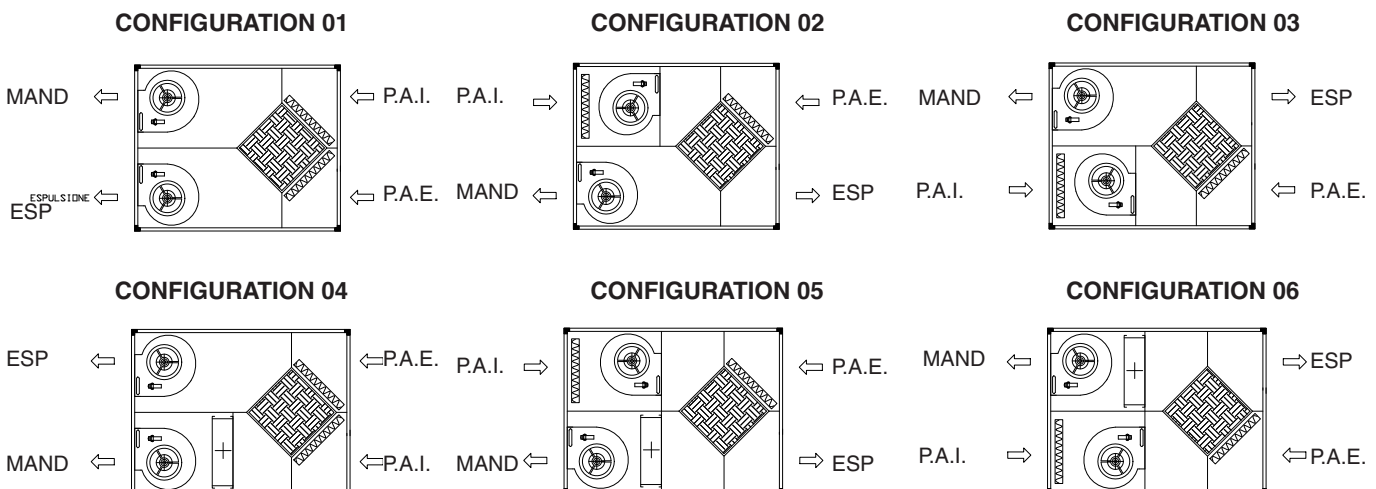

**Note:** Always indicate layout and configuration when ordering

Supply fan	005	01	02	03	04	
Air flow rate	500	1.000	2.000	3.000	4.000	m³/h
External static pressure	80	122	105	153	130	Pa
Power input	45	184	350	550	736	W
n° speed	3	3	3	3	3	n°
Return fan	005	01	02	03	04	
Air flow rate	500	1.000	2.000	3.000	4.000	m³/h
External static pressure	77	119	93	140	120	Pa
Power input	45	184	350	550	736	W
n° speed	3	3	3	3	3	n°
Performance UT REC DP	005	01	02	03	04	
Recovery type	cross flow and static type					
Recuperator	High efficiency aluminium plate exchanger					
P.A.I. (Room air)	22 / 50	22 / 50	22 / 50	22 / 50	22 / 50	°C/%
ESP (Exhaust air)	11,0 / 89	9,8 / 93	10,5 / 91	9,7 / 93	11,0 / 87	°C/%
P.A.E. (Ambient air)	-5 / 80	-5 / 80	-5 / 80	-5 / 80	-5 / 80	°C/%
MAND (Fresh air)	8,3 / 28	10,2 / 25	9,1 / 27	10,4 / 25	8,7 / 28	°C/%
REC (Heating recovery capacity)	2,2	5,1	9,5	15,5	18,4	kW
Efficiency recovery (sensible/latent)	49	57	52	57	51	%
Accessories BW	005	01	02	03	04	
Coil type	Cu/Al					
n° rows	2	2	2	2	2	n°
Coil connection	1/2"	3/4"	3/4"	3/4"	1"	ø
Inlet air / UR	8,4 / 28	10,0 / 25	9,1 / 27	10,0 / 25	8,7 / 28	°C/%
Outlet air / UR	27,5 / 8	31,9 / 11	25,4 / 13	25,6 / 13	24,9 / 15	°C/%
Water temperature IN/OUT	70 / 60	70 / 60	70 / 60	70 / 60	70 / 60	°C
Heating capacity	3,2	7,4	11,4	15,8	21,8	kW
Air pressure drop	10	17	45	53	55	Pa
Accessories BE	005	01	02	03	04	
Power supply	400 - 3 - 50					
Power input	2,5	5	10	15	15	kW
n° steps	1	1	2	2	2	n°

## Dimensions

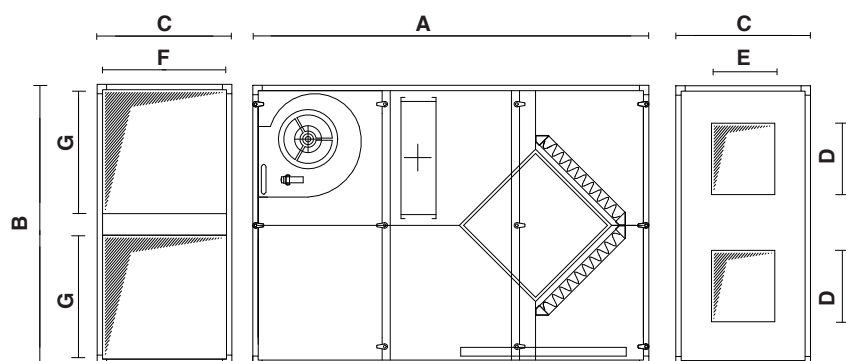

Mod.	UM	005	01	02	03	04
<b>A</b>	mm	1290	1310	1310	1660	1840
<b>B</b>	mm	1040	1040	1040	1250	1400
<b>C</b>	mm	400	500	500	600	650
<b>D</b>	mm	135	205	265	295	395
<b>E</b>	mm	225	235	235	265	341
<b>F</b>	mm	320	460	460	560	570
<b>G</b>	mm	380	380	380	470	555

# > UT REC DP F

DOUBLE PANEL HEAT RECOVERY UNIT  
WITH 4 ROWS EXCHANGER



## Units Series

Unit type

**UT-REC DP F** Horizontal unit

## Unit specifications

- **SUPPORT STRUCTURE:** in strong extruded aluminium profiles and double panel in galvanised steel sheet inside and prepainted galvanised steel sheet outside, with thermal insulation and soundproofing in hot-injected polyurethane foam, thick. 23 mm.
- **HEAT RECUPERATOR:** static-type in aluminium enabling recovery of the heat otherwise lost. Efficiency is guaranteed by the quality of the insulation.

- **CONDENSATE TRAY:** in steel sheet, it is placed under the recuperator for the condensate in summer mode.
- **AIR FILTER:** made with pleated filter cells, class G4 (ponderal eff. 90.1%), metal frame and electrowelded screen, easily removed from side.
- **FAN MOTOR:** a directly coupled type, three-speed with internal thermal protection and startup capacitor always on, with wheel statically and dynamically balanced to minimise noise and vibration.
- **HEAT EXCHANGER:** made with copper pipes arranged in staggered rows to increase heat exchange and aluminium fins locked by mechanical expansion of the pipes, with 4 rows for air conditioning and heating.

## Main accessories/Options

- Single-phase speed variator
- Safety microswitch
- Speed selector CV3
- Protection roof

## Layout

Unit are available in horizontal layout

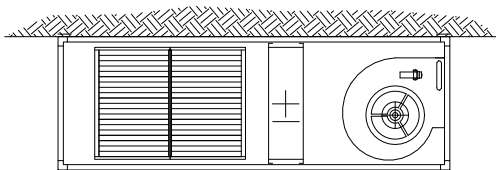

## Configuration

Depending on the configuration of the plant duct are available three possible configuration of recovery.

**CONFIGURATION 01**

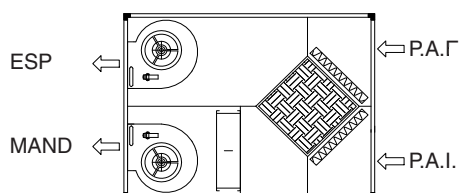

**CONFIGURATION 02**

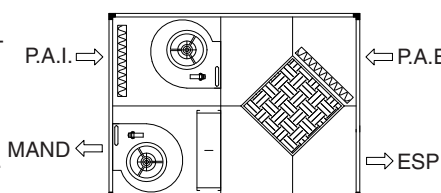

**CONFIGURATION 03**

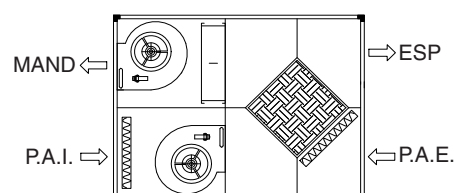

**Note:** Always indicate configuration when ordering

Supply fan	005	01	02	03	04	
Air flow rate	500	1.000	2.000	3.000	4.000	m³/h
External static pressure	55	155	75	95	65	Pa
Power input	45	350	550	550	1.100	W
n° speed	3	3	3	3	1	n°
Return fan	005	01	02	03	04	
Air flow rate	500	1.000	2.000	3.000	4.000	m³/h
External static pressure	90	116	125	142	104	Pa
Power input	45	184	550	550	1.100	W
n° speed	3	3	3	3	1	n°
Performance UT REC DP F	005	01	02	03	04	
Recovery type	cross flow and static type					
Recuperator	High efficiency aluminium plate exchanger					
P.A.I. (Room air)	27 / 48	28 / 50	28 / 50	28 / 50	28 / 50	°C/%
ESP (Exhaust air)	29,4 / 45	29,9 / 44	29,8 / 44	29,9 / 44	30 / 44	°C/%
P.A.E. (Ambient air)	32 / 50	32 / 50	32 / 50	32 / 50	32 / 50	°C/%
MAND (Fresh air)	30 / 57	30 / 55	30 / 55	30 / 55	30 / 56	°C/%
REC (Heating recovery capacity)	0,3	0,7	1,2	2	2,7	kW
Efficiency recovery (sensible/latent)	43	49	45	49	50	%
Performance 4R coil	005	01	02	03	04	
Coil type	Cu/Al					
n° rows	4	4	4	4	4	n°
Coil connection	1/2 "	3/4"	3/4"	1"	1"	ø
Inlet air / UR	30 / 57	30 / 55	30 / 55	30 / 55	30 / 56	°C/%
Outlet air / UR	16,4 / 97	18,8 / 94	19,1 / 92	18,9 / 92	18,5 / 93	°C/%
Water temperature IN/OUT	07/12	07/12	07/12	07/12	07/12	°C
Cooling capacity	4	5,5	11,4	17,1	24,8	kW

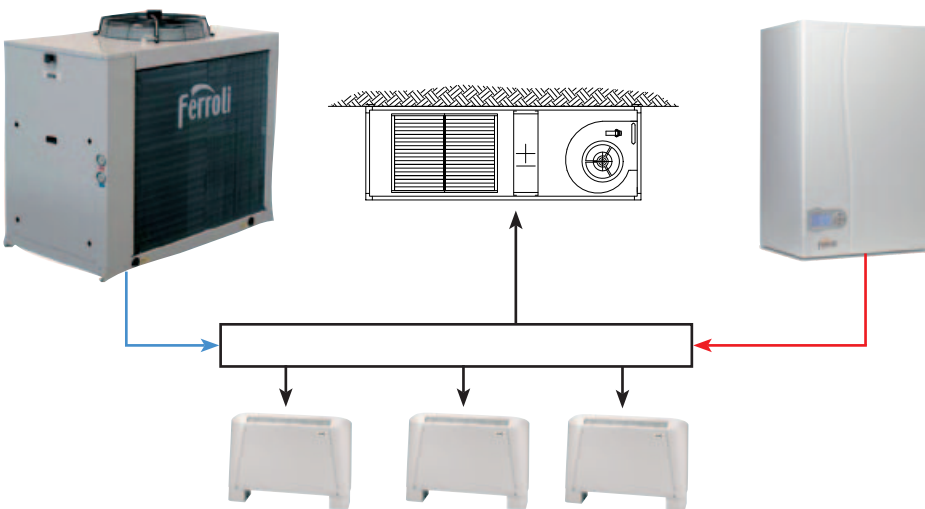

**NB:** For correct operation of the unit in heating, maximum delivery water temperatures up to T=50°C are acceptable. Therefore connection to a condensing-type boiler, as indicated in the diagram opposite, is advisable. If the unit is connected to a conventional boiler, the use of a 3-way valve with adjustment on the temperature of delivery to the system is indispensable.

**NB:** The unit is designed to integrate the primary air and therefore guarantee the air change in an existing system. It only guarantees cooling, and not conditioning (see example above).

**Dimensions**

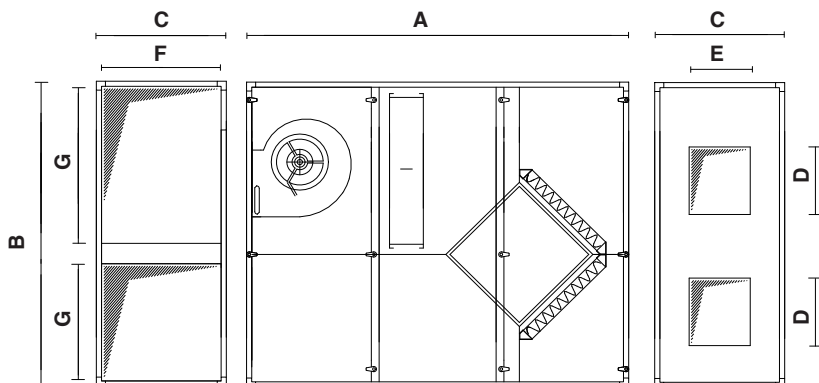

Mod.	UM	005	01	02	03	04
<b>A</b>	mm	1290	1540	1540	1790	2040
<b>B</b>	mm	1040	1040	1400	1790	2040
<b>C</b>	mm	400	500	500	600	650
<b>D</b>	mm	135	205	265	295	395
<b>E</b>	mm	225	235	235	265	341
<b>F</b>	mm	320	420	420	520	570
<b>G</b>	mm	380	380	380	640	640



# > EOLO

## EXHAUST AIR UNITS



### Units Series

Unit type  
**EOLO FK** direct drive

### Unit specifications

■ **CONSTRUCTION CHARACTERISTICS:** in aluzink sheet, with soundproofing interposed in the unit, guaranteed by an adequate thickness of polyester.

■ **ELECTRIC FANS:** the fans are dual-intake centrifugal type with statically and dynamically balanced wheels. EOLO FK Series 1 models have centrifugal electric fans with motor directly coupled. Vibration dampers are interposed between the structure and the fan to attenuate the transmission of any vibrations. The working temperature must be between -20°C and +40°C.

### Main accessories/Options

- Single-phase speed variator
- Three-phase speed variator
- Protection roof
- Bird net shroud
- Overpressure damper
- Support feet

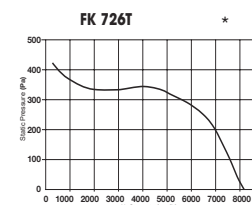
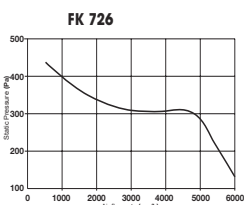
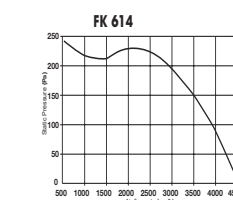
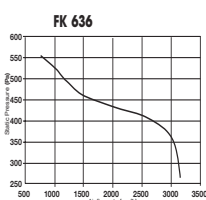
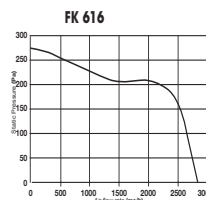
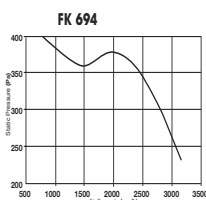
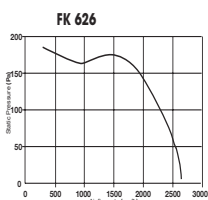
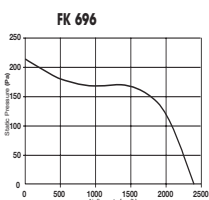
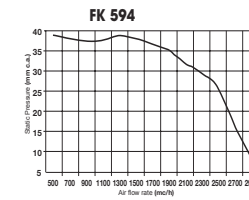
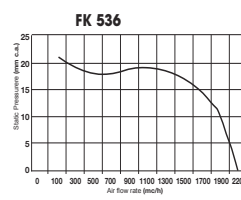
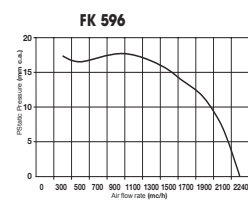
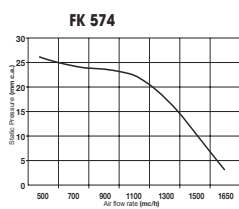
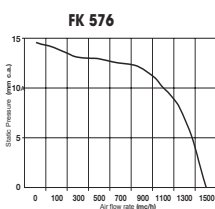

\* three-phases unit

### Dimensions

Mod.	UM	FK 576-574	FK 596-536-594	FK 696-626-694	FK 616-636-614	FK 726-726T*
A	mm	500	500	600	600	700
C	mm	171	179	179	208	234
D	mm	111	49	149	93	115
E	mm	129	129	146	129	147
F	mm	242	242	308	342	406
G	mm	218	272	272	299	351
Weight	kg	25-30	28-33	35-40	40-45	60

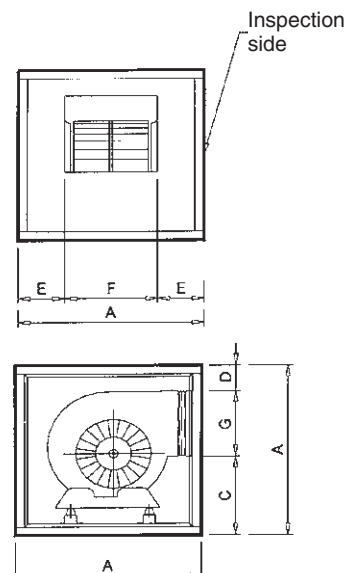

A series of horizontal dashed lines for writing, spanning the width of the page.



A series of horizontal dashed lines spanning the width of the page, providing a template for text entry.





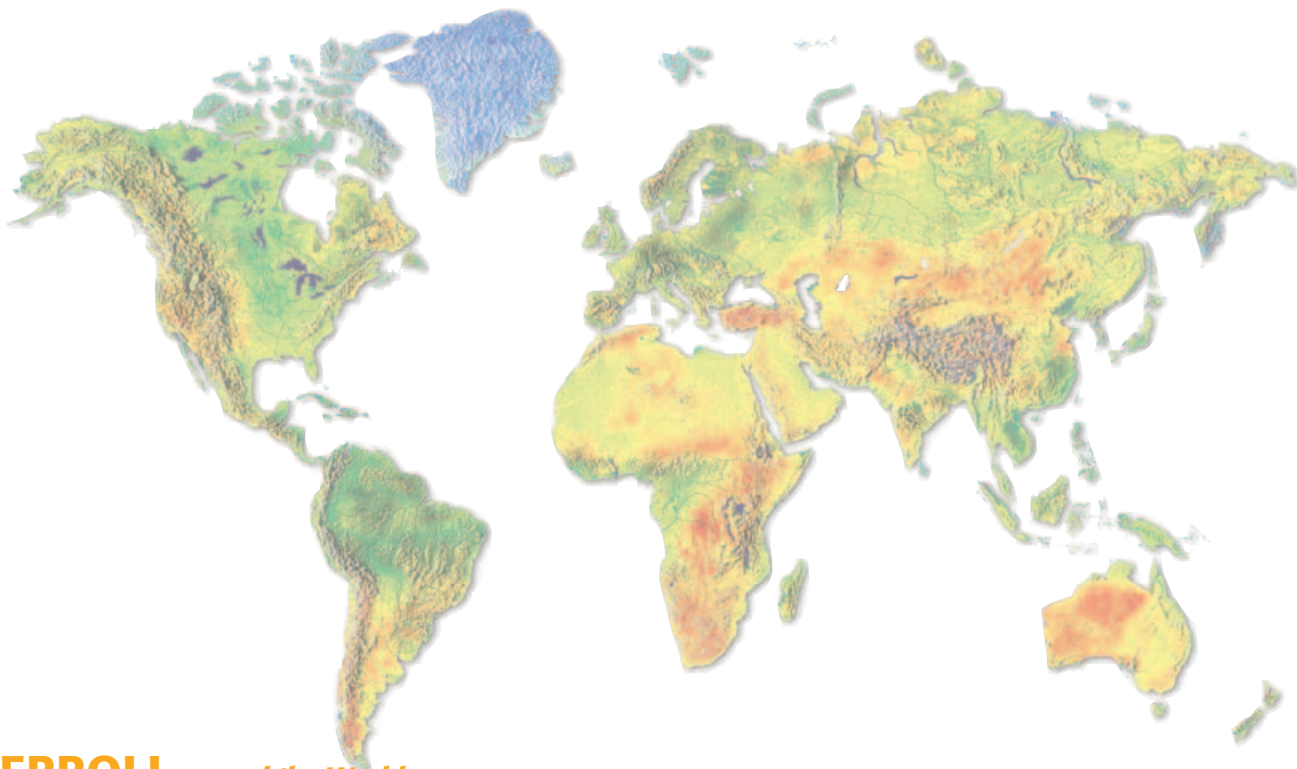

cod. 89CG0007/02 - 02.2012

## **FERROLI** *around the World*

**ITALY** [www.ferroli.it](http://www.ferroli.it)

**SPAIN** [www.ferroli.es](http://www.ferroli.es)

**FRANCE** [www.ferroli.fr](http://www.ferroli.fr)

**GERMANY** [www.ferroli.de](http://www.ferroli.de)

**UNITED KINGDOM** [www.dpac.co.uk](http://www.dpac.co.uk)

**NETHERLANDS** [www.ferroli.nl](http://www.ferroli.nl)

**ROMANIA** [www.ferroli.ro](http://www.ferroli.ro)

**TURKEY** [www.ferroli.com.tr](http://www.ferroli.com.tr)

**CROATIA** [www.ferroli.hr](http://www.ferroli.hr)

**HUNGARY** [www.ferroli.hu](http://www.ferroli.hu)

**POLAND** [www.ferroli.com.pl](http://www.ferroli.com.pl)

**UKRAINE** [www.ferroli.ua](http://www.ferroli.ua)

**RUSSIA** [www.ferroli-ac.ru](http://www.ferroli-ac.ru)

**BELARUS** [www.ferroli.klimatoff.com](http://www.ferroli.klimatoff.com)

**IRAN** [www.ferroli.ir](http://www.ferroli.ir)

**CHINA** [www.ferroli.com.cn](http://www.ferroli.com.cn)

**VIETNAM** [www.ferroli.com.vn](http://www.ferroli.com.vn)

WARNING FOR TRADERS: As part of its efforts to constantly improve its range of products, with the aim of increasing the level of Customer satisfaction, the Company stresses that the appearance, dimensions, technical data and accessories may be subject to variation. Consequently, ensure that the Customer is provided with updated documents.



Ferroli spa - 37047 San Bonifacio (Verona) Italy - Via Ritonda 78/A  
tel. +39.045.6139411 - fax +39.045.6103595  
[www.ferroli.it](http://www.ferroli.it)