

Ferrolli

October 2018

Hot Water Cylinders and Storage Tanks



CLIMA&COMFORT | RESIDENTIAL

HOT WATER CYLINDERS AND STORAGE TANKS



PRODUCT IN COMPLIANCE WITH EU REGULATIONS ON ECODSIGN* AND ENERGY LABELLING

* Minimum efficiency limits on global primary energy consumption for product & onboard heating system circulators

ECOGEO H-1 P
ECOGEO H-2 PC
ECOGEO H-2 SP
ECOUNTIT F 100-500
ECOUNTIT H 200-3000
ECOUNTIT H-1 200-3000
ECOUNTIT H-2 200-3000
ECOTANK H
ECOMULTI H
ECOMULTI H-1
ECOMULTI H-2
ECOPUFFER H 500-5000
ECOPUFFER H-1 500-5000

ECOGEO H-1 P VERTICAL HOT WATER STORAGE TANK FOR HEAT PUMP APPLICATION WITH ONE COIL



> GENERAL CHARACTERISTICS

ECOUNT H-1 P is a vertical hot water storage tank. This unit is designed for heating domestic hot water in combination with a Heat Pump. The units can be equipped by a series of electrical heaters as additional heating source. Steel (S235JR) tanks with enameled steel, that can be inspected through a flange placed on the lower part of the tank and equipped with a single fixed heat exchanger. The tank is protected by a layer of porcelain enamel that guarantees a long life. The enamel process and sizing of magnesium anodes (supplied as standard) are made according to DIN 4753 p.3. The thermal insulation is obtained by direct foamed PU, 50 mm thickness. The exterior jacket is made of coupled PVC

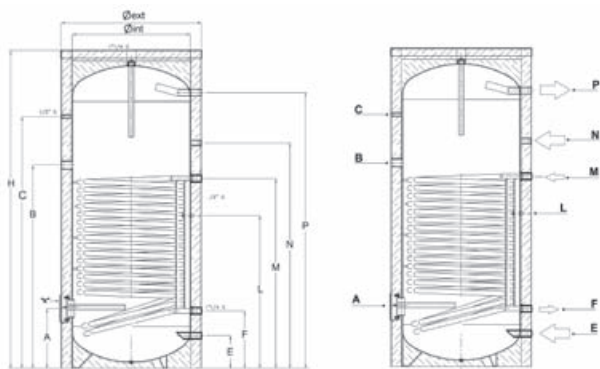

CONNECTIONS		200-1	300-1	500-1
A	Flange	mm 257	270	360
B	Electrical heaters connection	mm 940	1150	1335
C	Probe pocket	mm 1040	1430	1475
E	Water IN	mm 67	67	175
F	To heat pump	mm 210	230	295
L	Probe pocket	mm 593	653	825
M	From heat pump	mm 890	1080	1235
N	Ricirculation	mm 990	1200	1375
P	Water OUT	mm 1164	1609	1595
			type 1 1/2" G	1" G

TECHNICAL DATA		200-1	300-1	500-1
ERP Class	(F - A+ Class)	C	C	C
Total volume	l	192	276	473
Heat loss	W	66	81	102
External diameter	mm	605	605	750
Total height	mm	1265	1710	1785
Heat exchanger surface	m ²	3,0	3,8	5,9
Heat exchanger volume	l	18,5	23,1	36,3
Heating capacity	kW	47	59	92
DHW production	m ³ /h	1,1	1,4	2,2
Water flow	m ³ /h	4,1	5,1	7,9
Water pressure drop	kPa	0,74	0,94	1,42
DHW pressure	bar		10	
Max exchanger pressure	bar		10	
Max heating pressure	°C		95	
Max temperature tank	°C		110	
Weight	Kg	105	130	230
CODE		20Z14A00	20Z14A10	20Z14A20

ECOGEO H-2 PC VERTICAL HOT WATER STORAGE TANK FOR HEAT PUMP AND APPLICATION WITH TWO COILS

ERP



> GENERAL CHARACTERISTICS

ECOUNT H-2 PC is a vertical hot water storage tank.

This unit is designed for heating domestic hot water production in combination between an Heat Pump and a traditional heating source like a gas boiler.

The units can be equipped by an electric heating element as additional heating source.

Steel (S235JR) tanks with enameled steel, that can be inspected through a flange placed on the lower part of the tank and equipped with a double fixed heat exchanger.

The tank is protected by a layer of porcelain enamel that guarantees a long life.

The enamel process and sizing of magnesium anodes (supplied as standard) are made according to DIN 4753 p.3.

The thermal insulation is obtained by direct foamed PU for models 50 mm thickness.

The exterior jacket is made of coupled PVC

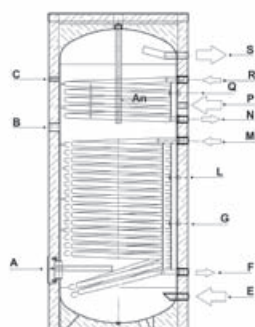
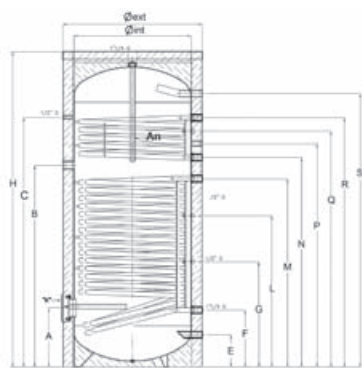

CONNECTIONS		350-2	500-2
A	Flange	mm 360	380
B	Electrical heaters connection	mm 950	1205
		type 1 1/2 G	
C	Probe pocket	mm 1295	1495
		type 1/2" G	
E	Water IN	mm 175	175
		type 1 1/4 G	
F	Heat pump out	mm 295	295
		type 1 1/4 G	
G	Sensor position	mm 490	575
		type 1/2" G	
L	Sensor position	mm 690	865
		type 1/2" G	
M	To heat pump	mm 885	1130
		type 1 1/4 G	
N	To auxiliary heat source	mm 1035	1265
		type 1 1/4 G	
P	Rircirculation	mm 1140	1420
		type 1" G	
Q	Sensor position	mm 1175	1405
		type 1/2" G	
R	From auxiliary heat source	mm 1245	1475
		type 1 1/4 G	
S	Water OUT	mm 1395	1595
		type 1 1/4 G	

TECHNICAL DATA		350-2	500-2
ERP Class	(F - A+ Class)	C	C
Total volume	l	350	500
Heat loss	W	96	104
External diameter	mm	750	750
Total height	mm	1580	1780
Lower heat exchanger surface	m ²	4,6	5,5
Lower heat exchanger volume	l	24,7	35
Lower coil heating capacity	kW	82	115
Lower coil DHW production	m ³ /h	2	2,8
Water flow at lower heat exchanger	m ³ /h	14	19,8
Water pressure drop at lower heat exchanger	kPa	0,97	1,38
Upper heat exchanger surface	m ²	0,9	0,9
Upper heat exchanger volume	l	5,3	5,3
Upper coil heating capacity	kW	27	27
Upper coil DHW production	m ³ /h	0,7	0,7
Water flow at upper heat exchanger	m ³ /h	1,1	1,1
Water pressure drop at upper heat exchanger	kPa	0,68	0,68
DHW pressure	bar		10
Max exchanger pressure	bar		10
Max heating pressure	°C		95
Max temperature tank	°C		110
Weight	Kg	175	210
CODE		20Z14A30	20Z14A40

ECOGEO H-2 SP

VERTICAL HOT WATER STORAGE TANK FOR SOLAR SYSTEM AND HEAT PUMP APPLICATION WITH TWO COILS

ERP



> GENERAL CHARACTERISTICS

ECOUNIT H-2 SP is a vertical hot water storage tank.

This unit is designed for heating domestic hot water production in combination between a Solar System and an Heat Pump.

The units can be equipped by an electric heating element as additional heating source.

Steel (S235JR) tanks with enameled steel, that can be inspected through a flange placed on the lower part of the tank and equipped with a double fixed heat exchanger.

The tank is protected by a layer of porcelain enamel that guarantees a long life.

The enamel process and sizing of magnesium anodes (supplied as standard) are made according to DIN 4753 p.3.

The thermal insulation is obtained by direct foamed PU for models 50 mm thickness.

The exterior jacket is made of coupled PVC

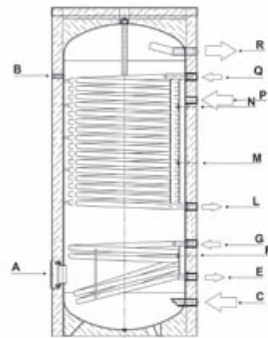
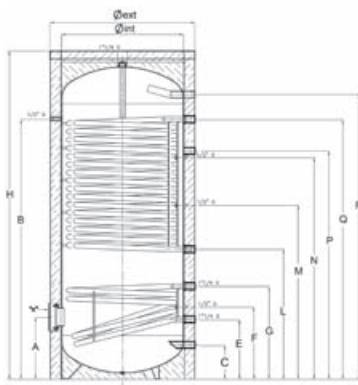

CONNECTIONS		350-2	500-2
A	Flange + Electrical heaters connection	mm	565
		type	1"1/2 G
B	Probe pocket	mm	1295
		type	1/2" G
C	Water IN	mm	175
		type	1"1/4 G
E	Solar circuit OUT	mm	295
		type	1"1/4 G
F	Sensor position for solar	mm	395
		type	1/2" G
G	Solar circuit IN	mm	505
		type	1"1/4 G
L	To heat pump	mm	625
		type	1"1/4 G
P	Ricirculation	mm	1036
		type	1" G
M	Sensor position for heat pump	mm	845
		type	1/2" G
N	Probe pocket	mm	1065
		type	1/2" G
Q	From heat pump	mm	1275
		type	1"1/4 G
S	Water OUT	mm	1395
		type	1"1/4 G

TECHNICAL DATA		350-2	500-2
ERP Class	(F - A+ Class)	C	C
Total volume	l	350	500
Heat loss	W	94	103
External diameter	mm	760	760
Total height	mm	1580	1780
Lower heat exchanger surface	m ²	0,9	0,9
Lower heat exchanger volume	l	5,3	5,3
Lower coil heating capacity transfer	kW	27	27
Lower coil DHW production	m ³ /h	0,7	0,7
Water flow at lower heat exchanger	m ³ /h	1,1	1,1
Water pressure drop at lower heat exchanger	kPa	0,68	0,68
Upper heat exchanger surface	m ²	4,6	5,5
Upper heat exchanger volume	l	25	34
Upper coil heating capacity transfer	kW	72	86
Upper coil DHW production	m ³ /h	1,7	2,1
Water flow at upper heat exchanger	m ³ /h	6,2	7,4
Water pressure drop at upper heat exchanger	kPa	0,97	1,33
DHW pressure	bar		10
Max exchanger pressure	bar		10
Max heating pressure	°C		95
Max temperature tank	°C		110
Weight	Kg	177	215
CODE		20Z14980	20Z14990

ECOUNTIT F 100-500 DOMESTIC HOT WATER STORAGES WITH SINGLE-DOUBLE COIL

ERP



> PRODUCT SPECIFICATIONS

- Vertical storage tanks for DHW, with single heat exchanger/coil (version 1C) or double heat exchanger/coil (version 2C), made by enamelled steel, for solar systems.
- Rigid insulation 50 mm thickness, externally wrapped in white painted steel.
- Supplied as standard with magnesium anode and electrical backup resistor (1500 Watt), adjustable temperature setpoint: 15-75°C
- 3 probe sockets

DIMENSIONS (mm)										
	100-1C	150-1C	200-1C	300-1C	400-1C	500-1C	200-2C	300-2C	400-2C	500-2C
A	500	500	540	620	750	750	540	620	750	750
B	978	1325	1453	1535	1469	1769	1453	1535	1469	1769
C	870	1216	1344	1431	1326	1626	1344	1431	1326	1626
D	736	1088	1084	1161	985	1261	1234	1311	1174	1474
E	636	988	984	1061	885	1161	1134	1211	1074	1374
F	536	888	884	961	785	1061	1034	1111	974	1274
G	336	336	334	361	441	441	934	961	852	1152
H	236	236	234	261	341	341	834	861	752	1052
I	126	126	124	131	155	155	734	761	661	898
J	-	-	-	-	-	-	234	261	391	398
K	-	-	-	-	-	-	124	131	291	298
L	-	-	-	-	-	-	324	351	155	155
M	400	400	440	520	650	650	440	520	650	650
N	326	326	324	351	418	418	324	351	418	418

HYDRAULIC CONNECTIONS										
	100-1C	150-1C	200-1C	300-1C	400-1C	500-1C	200-2C	300-2C	400-2C	500-2C
DHW	3/4"	3/4"	3/4"	1"	1"	1"	3/4"	1"	1"	1"
Heat exchanger/coil(s)	3/4"	3/4"	3/4"	1"	1"	1"	3/4"	3/4"	1"	1"
DHW recirculation feed	3/4"	3/4"	3/4"	1"	1"	1"	3/4"	3/4"	3/4"	3/4"

> NOMENCLATURE

- hot water outlet
- boiler inlet
- temperature probe
- DHW recirculation feed
- thermal probe
- boiler outlet
- cold water inlet
- temperature probe
- solar circuit inlet
- solar circuit outlet

ECOUNTIT F VERSION 1C

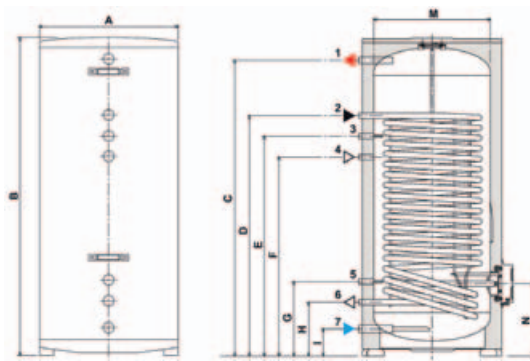

ECOUNTIT F VERSION 2C

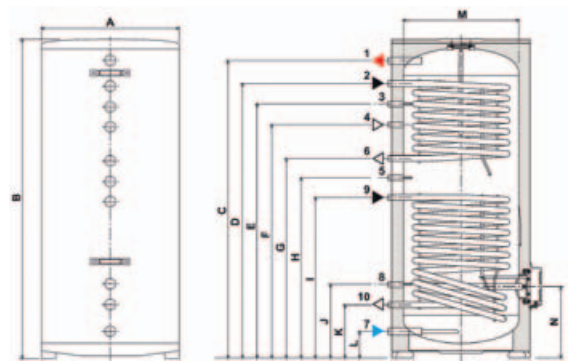

MODEL		SINGLE COIL						DOUBLE COIL			
		100-1C	150-1C	200-1C	300-1C	400-1C	500-1C	200-2C	300-2C	400-2C	500-2C
ERP Class	(F - A+ Class)	C	C	C	C	C	C	C	C	C	C
Total capacity	l	89	129	173	261	335	460	174	262	356	461
Nominal power of the coil (Δt 35°C, upp/low)	m²	0,74	1,25	1,4	1,83	2,37	3,39	0,5/0,83	0,72/1	1,19/1,52	1,19/2,2
Coil surface (upp/low)	KW	18,5	31,25	35	45,75	59,25	84,75	12,5/20,75	18/25	29,6/38,1	29,6/55
Hydraulic losses of the coil (upp/low)	mbar	228	386	432	565	118	167	155/254	220/308	58/75	58/109
Thermal losses with water temp. 65°C	m²	0,74	1,25	1,4	1,83	2,37	3,39	0,5 / 0,83	0,72 / 1	1,19 / 1,52	1,19 / 2,2
Max operating temperature	kWh/24h	1,6	1,8	2,2	2,7	2,9	3,5	2,2	2,7	2,9	3,5
Primary circuit flow	°C	95	95	95	95	95	95	95	95	95	95
Max operating pressure	m³/h	2	2	2	2	2	2	2	2	3	3
Weight (empty)	bar	8	8	8	8	8	8	8	8	8	8
Weight of the tank	kg	45	64	73	103	126	155	73	102	126	155
CODE		GRZ1010A	GRZ3010A	GRZ4110A	GRZ6310A	GRZ7410A	GRZ8410A	GRZ4120A	GRZ6320A	GRZ7420A	GRZ8420A

ECOUNTIT H 200-3000 VERTICAL HOT WATER STORAGE TANK



> GENERAL CHARACTERISTICS

ECOUNTIT H is a vertical hot water storage tank.

This unit is designed for heating domestic hot water to a temperature below boiling point at atmospheric pressure.

The units can be equipped by a series of electrical heaters as heating source.

Steel (S235JR) tanks with enameled steel, with capacities from 200 to 3000 liters, that can be inspected through a flange placed on the lower part of the tank and equipped with a double fixed heat exchanger.

The tank is protected by a layer of porcelain enamel that guarantees a long life.

The enamel process and sizing of magnesium anodes (supplied as standard) are made according to DIN 4753 p.3.

The thermal insulation is obtained by direct foamed PU for models up to 500 lt.

Rigid PU shells are used for the 750 and 1000 lt models and polyester fiber for models from 1500 to 3000 lt.

The exterior jacket is made of coupled PVC

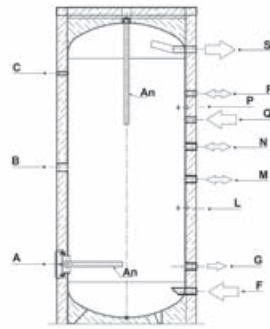
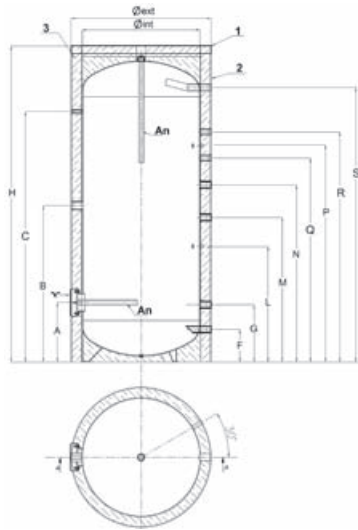

CONNECTIONS		200	300	400	500	750	1000	1500	2000	2500	3000
A	Flange	mm 257	257	268	335	400	400	520	550	640	640
B	Electrical heaters connection	mm 629	914	891	949	890	890	1255	1310	1400	1400
C	Probe pocket	mm 929	1384	1411	1480	1460	1680	1825	2090	2130	2430
F	Water IN	mm 110	110	120	175	220	220	315	340	430	430
G	Free connection	mm 264	264	286	305	385	385	470	460	550	550
L	Probe pocket	mm 474	654	660	685	685	685	945	985	1075	1075
M	Free connection	mm 579	849	846	865	835	835	1180	1160	1250	1300
N	Free connection	mm 679	979	1011	985	990	990	1330	1450	1540	1790
Q	Ricirculation	mm 884	1141	1163	1235	1235	1235	1460	1650	1740	2040
P	Probe pocket	mm 914	1214	1245	1285	1340	1340	1600	1825	1905	2205
R	Free connection	mm 994	1294	1361	1335	1440	1440	1735	2000	2040	2340
S	Water OUT	mm 1120	1565	1540	1595	1590	1840	1935	2210	2250	2550

MODEL		200	300	400	500	750	1000	1500	2000	2500	3000
ERP Class	(F - A+ Class)	C	C	C	C	N.D.	N.D.	N.D.	N.D.	N.D.	N.D.
Total volume	l	212	297	420	513	763	885	1494	2013	2408	2841
Heat loss	W	74	88	105	116	115	125	146	172	330	354
External diameter	ø mm	600	600	700	750	950	950	1200	1300	1400	1400
Total height	mm	1265	1710	1655	1785	1845	2095	2285	2550	2680	2980
Weight	Kg	58	76	91	103	173	194	322	396	524	579
Max tank pressure	bar	10									
Max tank temperature	°C	95									
CODE		OYHA3AXA	OYHA4AXA	OYHA5AXA	OYHA6AXA	OYHA8AXA	OYHA9AXA	OYHABAXA	OYHACAXA	OYHAEAXA	OYHADAXA

ECOUNT H-1 200-3000 VERTICAL HOT WATER STORAGE TANK WITH SINGLE COIL

ERP



> GENERAL CHARACTERISTICS

ECOUNT H-1 is a vertical DHW storage tank with single coil.

This unit is designed for heating domestic hot water to a temperature below boiling point at atmospheric pressure.

Enamelled steel (S235JR) tanks, with capacities from 200 to 3000 liters. It can be inspected through a flange placed on the lower part of the tank.

The tank is protected by a layer of porcelain enamel that guarantees a long life.

The enamel process and sizing of magnesium anodes (supplied as standard) are made according to DIN 4753 p.3.

The thermal insulation is obtained by direct foamed PU for models up to 500 lt.

Rigid PU shells are used for the 750 and 1000 lt models and polyester fiber for models from 1500 to 3000 lt.

The exterior jacket is made of coupled PVC

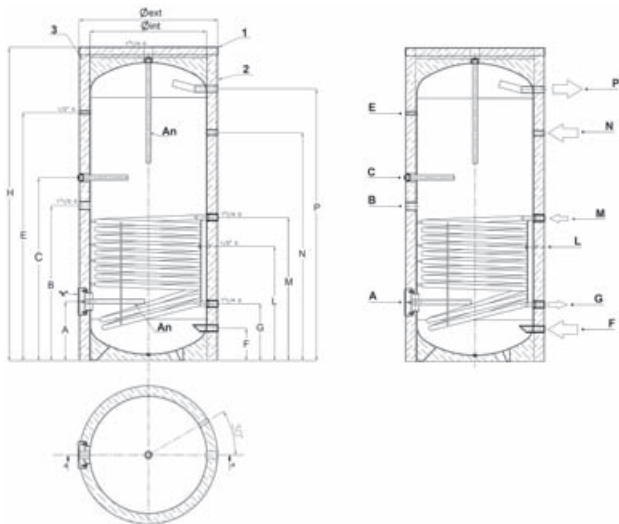

CONNECTIONS		200	300	400	500	750	1000	1500	2000	2500	3000	
A	Flange	mm 257	257	268	335	400	400	520	550	640	640	
B	Electric heater	mm 797	986	980	1150	1050	1050	1255	1310	1500	1400	
		type 1"1/2 G										
C	Anode connection	mm \	\	\	\	\	\	\	\	\	1640	
E	Probe pocket	mm 997	1431	1385	1400	1430	1680	1825	2090	2130	2430	
		type 1/2" G										
F	Water IN	mm 67	67	79	175	220	220	315	340	430	430	
		type 1" G		1"1/4 G			2" G					
G	Coil OUT	mm 263	263	314	320	385	385	470	460	550	550	
		type 1"1/4 G										
L	Sensor position for heating	mm 593	653	689	825	775	870	943	985	1075	1075	
		type 1/2" G										
M	Coil IN	mm 758	848	874	1075	970	970	1180	1160	1250	1300	
		type 1"1/4 G										
N	Circulation connection	mm 915	1140	1204	1315	1350	1545	1460	1650	1740	2040	
		type 3/4" G		1" G								
P	Water OUT	mm 1164	1609	1541	1595	1590	1840	1935	2210	2250	2550	
		type 1" G		1"1/4 G			2" G					

MODEL		200-1	300-1	400-1	500-1	750-1	1000-1	1500-1	2000-1	2500-1	3000-1
ERP Class	(F - A+ Class)	C	C	C	C	N.D.	N.D.	N.D.	N.D.	N.D.	N.D.
Total volume	l	204	286	396	500	748	868	1466	1977	2479	2809
External diameter	ø mm	610	610	710	760	950	950	1200	1300	1400	1400
Total height	mm	1265	1710	1655	1785	1845	2095	2285	2550	2680	2980
Heat exchanger surface	m ²	1,1	1,5	1,8	2,0	2,5	2,5	4,2	4,5	4,8	5,2
Heat exchanger volume	l	7,4	8,8	11,2	12,4	15,0	15,0	25,4	28,0	29,5	31,6
Heating capacity	KW	32,6	44,5	53,4	59,3	74,1	74,1	124,5	133,4	142,3	154,2
DHW production	m ³ /h	0,8	1,09	1,3	1,46	1,8	1,8	3,06	3,3	3,5	3,8
Water flow	m ³ /h	1,4	1,9	2,3	2,6	3,2	3,2	5,4	5,7	6,1	6,6
Water pressure drop	kPa	0,94	1,12	1,42	1,58	1,90	1,90	3,23	3,56	3,76	4,03
Weight	kg	75	97	118	135	206	227	380	458	593	653
Heat loss	W	67	81	96	102	113	121	153	180	282	304
DHW pressure	bar	10									
Max exchanger pressure	bar	10									
Max heating pressure	°C	110									
Max temperature tank	°C	95									
CODE		OYH03AXA	OYH04AXA	OYH05AXA	OYH06AXA	OYH08AXA	OYH09AXA	OYH0BAXA	OYH0CAXA	OYH0EAXA	OYH0DAXA

ECOUNTIT H-2 200-3000 VERTICAL HOT WATER STORAGE TANK WITH DOUBLE COIL



> GENERAL CHARACTERISTICS

ECOUNTIT H-2 is a vertical DHW storage tank with double coil.

This unit is designed for heating domestic hot water to a temperature below boiling point at atmospheric pressure. Indirect heating by two energy sources.

Enamelled steel (S235JR) tanks, with capacities from 200 to 3000 liters. It can be inspected through a flange placed on the lower part of the tank.

These models are used for the production of domestic hot water through solar thermal and a boiler.

The tank is protected by a layer of porcelain enamel that guarantees a long life.

The enamel process and sizing of magnesium anodes (supplied as standard) are made according to DIN 4753 p.3.

The thermal insulation is obtained by direct foamed PU for models up to 500 lt.

Rigid PU shells are used for the 750 and 1000 lt models and polyester fiber for models from 1500 to 3000 lt.

The exterior jacket is made of coupled PVC

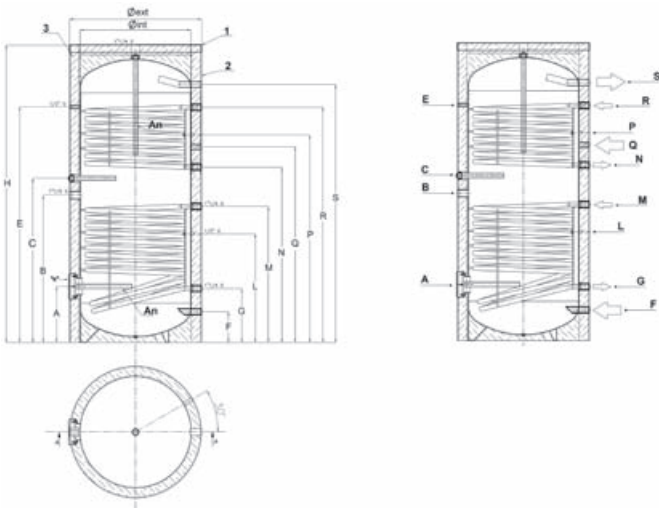

CONNECTIONS		200	300	400	500	750	1000	1500	2000	2500	3000
A	Flange	mm 257	257	268	335	400	400	520	550	640	640
B	Electrical heaters connection	mm 629	914	891	949	890	890	1255	1310	1400	1400
		type 1"1/2 G									
C	Anode connection	mm \	\	\	\	\	\	\	\	\	1640
E	Probe pocket	mm 929	1384	1411	1480	1460	1680	1825	2090	2130	2430
		type 1/2" G									
F	Water IN	mm 67	67	79	175	220	220	315	340	430	430
		type 1" G		1"1/4 G			2" G				
G	Solar circuit OUT	mm 264	264	286	305	385	385	470	460	550	550
		type 1"1/4 G									
L	Sensor position for Solar	mm 474	654	660	685	685	685	945	985	1075	1075
		type 1/2" G									
M	Solar circuit IN	mm 579	849	846	865	835	835	1180	1160	1250	1300
		type 1"1/4 G									
N	Heating circuit OUT	mm 679	979	1011	985	990	990	1330	1450	1540	1790
		type 1"1/4 G									
Q	Recirculation	mm 884	1141	1163	1235	1235	1235	1460	1650	1740	2040
		type 3/4" G		1" G							
P	Sensor position for heating	mm 914	1214	1245	1285	1340	1340	1600	1825	1905	2205
		type 1/2" G									
R	Heating circuit IN	mm 994	1294	1361	1335	1440	1440	1735	2000	2040	2340
		type 1"1/4 G									
S	Water OUT	mm 1164	1609	1541	1595	1590	1840	1935	2210	2250	2550
		type 1" G		1"1/4 G			2" G				

MODEL		200-2	300-2	400-2	500-2	750-2	1000-2	1500-2	2000-2	2500-2	3000-2
ERP Class	(F - A+ Class)	C	C	C	C	N.D.	N.D.	N.D.	N.D.	N.D.	N.D.
Total volume	l	201	282	401	495	734	853	1451	1959	2458	2786
Heat loss	W	67	81	96	102	113	121	153	180	284	305
External diameter	mm	610	610	710	760	950	950	1200	1300	1400	1400
Total height	mm	1265	1710	1655	1785	1845	2095	2285	2550	2680	2980
Lower heat exchanger surface	m ²	0,8	1,5	1,9	1,9	2,4	2,5	4,2	4,5	4,8	5,2
Lower heat exchanger volume	l	4,9	8,8	11,2	11,6	15,0	15,0	25,4	28,0	29,5	31,6
Lower coil heating capacity transfer	kW	32,6	44,5	53,4	59,3	74,1	74,1	124,5	133,4	142,3	154,2
Lower coil DHW production	m ³ /h	0,8	1,09	1,3	1,46	1,8	1,8	3,06	3,3	3,5	3,8
Water flow at lower heat exchanger	m ³ /h	1,4	1,9	2,3	2,6	3,2	3,2	5,4	5,7	6,1	6,6
Water pressure drop at lower heat exchanger	kPa	0,63	0,63	0,78	0,78	1,90	1,90	1,94	2,37	2,68	2,95
Upper heat exchanger surface	m ²	0,8	0,9	0,9	0,9	2,4	2,5	2,5	3,0	3,5	3,8
Upper heat exchanger volume	l	4,9	4,9	6,1	6,1	15,0	15,0	15,2	18,7	21,1	23,2
Upper coil heating capacity transfer	kW	23,7	23,7	26,7	56,3	71,2	71,2	71,2	89,0	103,8	112,7
Upper coil DHW production	m ³ /h	0,58	0,58	0,66	1,38	1,75	1,75	1,75	2,2	2,55	2,77
Water flow at upper heat exchanger	m ³ /h	1,0	1,0	1,1	2,4	3,1	3,1	3,1	3,8	4,5	4,8
Water pressure drop at upper heat exchanger	kPa	0,63	1,12	1,42	1,47	1,90	1,90	3,23	3,56	3,76	40,3
Max tank/coil pressure	bar	10 / 10									
Max tank/coil temperature	°C	95 / 110									
Weight	Kg	75	97	118	135	206	227	380	458	593	653
CODE		OYH53AXA	OYH54AXA	OYH55AXA	OYH56AXA	OYH58AXA	OYH59AXA	OYH5BAXA	OYH5CAXA	OYH5EAXA	OYH5DAXA

ECOTANK H BOILER DUPLEX SERIES

CARBON-STEEL TANKS OF THE TANK-IN-TANK TYPE

ERP



> GENERAL CHARACTERISTICS

Carbon-steel tanks for DHW storage tank-in-tank type, capacity 800/200, 1500/300 equipped with single fixed exchanger.

Second internal tank for DHW storage of enamelled carbon-steel in compliance with the DIN 4753 p.3 Standard.

Special extended shape for significant temperature stratification.

Externally insulated by a soft polyurethane blanket, (100mm thickness)

Ecotank H is used for producing domestic hot water and for heating

CONNECTIONS	800/1500
A	Coil OUT 1" G
B	Free connection 1" G
C	Free connection 1" G
E	Electric heater 1 1/2" G
F	Free connection 1" G
G	Coil IN 1" G
L	Draining 1" G
M	Return heat exchanger 1" G
N	Solar Probe 1/2" G
P	Solar Probe 1/2" G
Q	Supply heat exchanger 1" G
R	Probe 1/2" G
S	Probe 1/2" G
T	Thermometer 1/2" G
V	Electric heater 1 1/2" G
1	Cold water (external thread) 1" G
2	Recirculation (external thread) 1" G
3	Hot water (external thread) 1" G
4	Draining (internal thread) 1/2" G

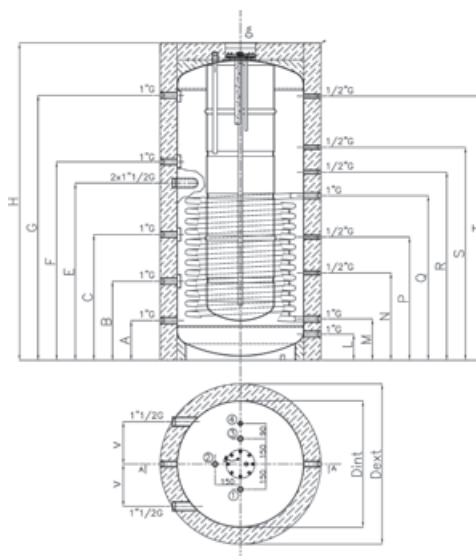

DIMENSIONS (mm)	800	1500
A	235	390
B	468	665
C	745	940
D ext	950	1200
D int	750	1000
E	1050	1200
F	1050	1500
G	1570	1710
H total	1880	2100
L	155	205
M	245	380
N	--	630
P	730	875
Q	975	1125
R	1115	1310
S	1262	1500
T	1565	1710
V	250	300

MODEL		800	1500
Total volume (Heating + DHW)	l	750	1500
Volume for inner tank	l	200	300
Volume of the buffer tank	l	550	1200
Heat exchanger surface	m ²	2,5	3,9
Heat exchanger volume	l	15,9	24,7
Solar coil power	kW	74	116
Heat exchanger	m ³ /h	3,2	5
Water production 80/60°C	m ³ /h	1,8	2,8
Heat exchanger (flow 1m ³ /h)	kPa	3,55	5,17
Weight	kg	217	307
Total heat loss	W	116	149
DHW pressure	bar	10	10
Max exchanger pressure	bar	10	10
Max heating pressure	bar	3	3
Max temperature tank	°C	95	95
CODE		OYH28AXA	OYH2BAXA

ECOMULTI H MULTI-ENERGY BUFFER WITH SEMI-INSTANT DHW COIL

ERP



> GENERAL CHARACTERISTICS

Carbon-steel tank of the pipe-in-tank type, capacity 500-800-1000 litres.

Equipped with an AISI 316L stainless steel corrugated coil that acts.

Possibility to use the system as a multi-energy "buffer" with parallel connection of several sources (Boiler + solar + heat pump or biomass boiler)

The tanks are insulated externally by a soft polyurethane blanket (100 mm thickness)

6 probe wells + 1 for electrical resistance

No consumption of sacrificial anode (the production of DHW is obtained with the internal semi-rapid exchanger in stainless steel AISI 316)

These models are used for producing hot water for domestic use (semi-fast), and storage of system hot water for heating.

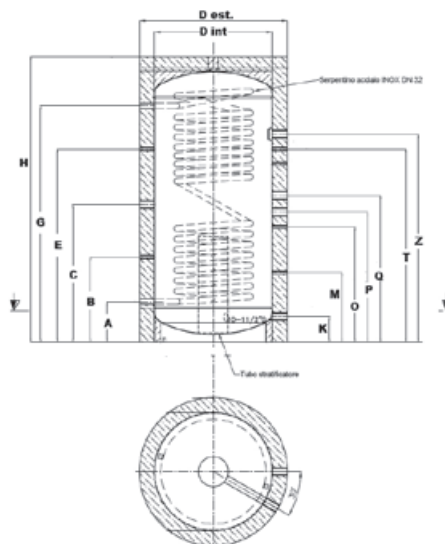

CONNECTIONS	500-800	1000	
1. (A)	Tap water IN	1" G	1" G
2. (B)	Probe	1/2" G	1/2" G
3. (C)	Electric heater	1" 1/2 G	1" 1/2 G
4.(E)	Boiler probe	1/2" G	1/2" G
6. (G)	DHW OUT	1" G	1" G
7. (K)	Coil OUT	1" 1/4 G	1" 1/2 G
8. (K)	Coil IN	1" 1/4 G	1" 1/2 G
11. (N)	Supply solar exchanger	1" G	1" G
12. (O)	Heater probe	1/2" G	1/2" G
13. (P)	Connections	1" 1/2 G	1" 1/2 G
14. (Q)	Connection	1" 1/2 G	1" 1/2 G
17. (T)	Thermometer	1/2" G	1/2" G
20. (Z)	Coil IN	1" 1/2 G	1" 1/2 G

DIMENSIONS (mm)	500	800	1000
A	240	270	270
B	440	570	580
C	820	920	1130
D ext	850	990	990
D int	650	790	790
E	1150	1290	1500
G	1420	1580	1760
H tot	1720	1910	2090
K	150	170	170
N	640	670	730
O	--	770	840
P	810	870	950
Q	--	870	950
T	1170	1190	1330
Z	1400	1390	1520

MODEL		500	800	1000
ERP Class	(F - A+ Class)	C	N.D.	N.D.
Total volume	l	500	800	1000
Heat exchanger volume	m ²	5,64	5,64	5,64
Inside enamelled tank volume	l	35	35	35
Water production	m ³ /h	0,417	0,660	1,230
80/60°C - 10/45°C	KW	17	27	50
Weight	kg	113	159	171
Total heat loss	W	88	115	122
DHW pressure	bar	6	6	6
Max exchanger pressure	bar	10	10	10
Max heating pressure	bar	3	3	3
Max temperature tank	°C	95	95	95
CODE		OYH76AXA	OYH78AXA	OYH79AXA

ECOMULTI H-1 MULTI-ENERGY BUFFER WITH SEMI-INSTANT DHW COIL AND ONE SOLAR COIL

ERP

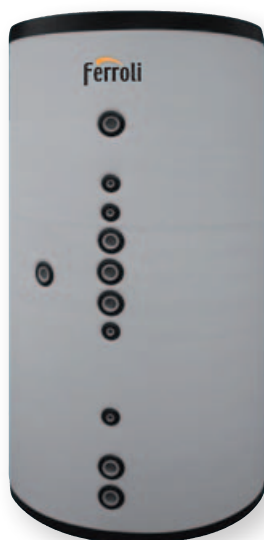

> GENERAL CHARACTERISTICS

Carbon-steel tank of the pipe-in-tank type, capacity 500-800-1000 litres.

Equipped with a fixed single exchanger for connection to solar thermal. Additionally an AISI 316L stainless steel corrugated coil acts as a water tank for domestic use.

Possibility to use the system as a multi-energy "buffer" with parallel connection of several sources (Boiler + solar + heat pump or biomass boiler)

The tanks are insulated externally by a soft polyurethane blanket (100mm thickness)

6 probe wells + 1 for electrical resistance

No need of sacrificial anode (the production of DHW is obtained with the internal semi-rapid exchanger in stainless steel AISI 316) .

These models are used for producing hot water for domestic use (semi-fast), and storage of system hot water for heating.

CONNECTIONS	500-1 / 800-1	1000-1
1. (A) Water IN	1" G	1" G
2. (B) Probe	1/2" G	1/2" G
3. (C) Electric heater	1" 1/2 G	1" 1/2 G
4. (E) Boiler probe	1/2" G	1/2" G
6. (G) DHW inlet	1" G	1" G
7. (K) Coil OUT	1" 1/4 G	1" 1/2 G
8. (K) Coil IN	1" 1/4 G	1" 1/2 G
9. (L) Return solar exchanger	1" G	1" G
10. (M) Solar probe	1/2" G	1/2" G
11. (N) Supply solar exchanger	1" G	1" G
12. (O) Probe heater	1/2" G	1/2" G
13. (P) Connections	1" 1/2 G	1" 1/2 G
14. (Q) Connection	1" 1/2 G	1" 1/2 G
17. (T) Thermometer	1/2" G	1/2" G
18. (Z) Connection	1" 1/2 G	1" 1/2 G

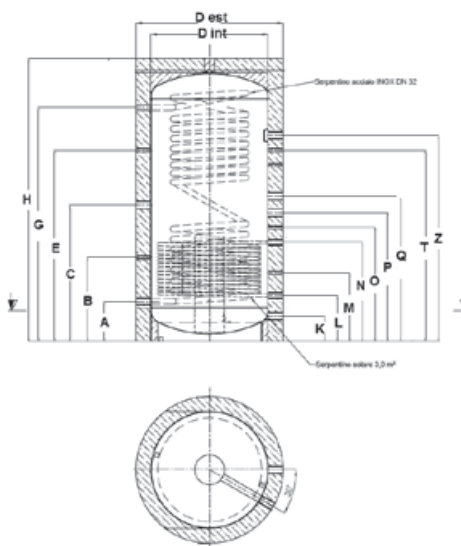

DIMENSIONS (mm)	500-1	800-1	1000-1
A	240	270	270
B	440	570	580
C	820	920	1130
D est	850	990	990
D int	650	790	790
E	1150	1290	1500
G	1420	1580	1760
H tot	1720	1910	2090
K	150	170	170
L	280	310	310
M	490	465	495
N	640	670	730
O	--	770	840
P	810	870	950
Q	--	870	950
T	1170	1190	1330
Z	1400	1390	1520

MODEL		500-1	800-1	1000-1
ERP Class	(F - A+ Class)	C	N.D.	N.D.
Total volume	l	500	800	1000
DHW coil surface	m ²	5,64	5,64	5,64
DHW coil water content	l	35	35	35
Heat exchanger surface	m ²	2,3	3,0	3,0
Heat exchanger volume	l	12,4	14,9	14,9
Heat exchanger power	KW	68	89	89
Necessary flow heat exchanger	m ³ /h	2,9	3,8	3,8
Water production 80/60°C	m ³ /h	1,7	2,2	2,2
Pressure drop heat exchanger (flow 1m ³ /h)	kPa	1,71	2,14	2,14
Water production 80/60°C - 10/45°C	m ³ /h	0,417	0,660	1,230
	KW	17	27	50
Weight	kg	141	194	206
Total heat loss	W	90	116	122
DHW pressure	bar	6	6	6
Max exchanger pressure	bar	10	10	10
Max heating pressure	bar	3	3	3
Max temperature tank	°C	95	95	95
CODE		OYH86AXA	OYH88AXA	OYH89AXA

ECOMULTI H-2 MULTI-ENERGY BUFFER WITH DOUBLE SYSTEM COIL AND SEMI-INSTANT DHW EXCHANGER

ERP



> GENERAL CHARACTERISTICS

Double exchanger for DHW exchanger purpose and an AISI 316L stainless steel corrugated coil that acts as a semi-instant producer of DHW.

Possibility to use the system as a multi-energy "buffer" with parallel connection of several sources (Boiler + solar + heat pump or biomass boiler)

The tanks are insulated externally by a soft polyurethane blanket (100mm thickness)

6 probe wells + 1 for electrical resistance

No need of sacrificial anode (the production of DHW is obtained with the internal semi-rapid exchanger in stainless steel AISI 316)

These models are used for producing hot water for domestic use (semi-fast) and storage of system hot water for heating.

CONNECTIONS		500-2/800-2	1000-2
1. (A)	Water IN	1" G	1" G
2. (B)	Probe	1/2" G	1/2" G
3. (C)	Electric heater	1" 1/2 G	1" 1/2 G
4. (E)	Boiler probe	1/2" G	1/2" G
6. (G)	DHW inlet	1" G	1" G
7. (K)	Coil OUT	1" 1/4 G	1" 1/2 G
8. (K)	Coil IN	1" 1/4 G	1" 1/2 G
9. (L)	Return solar exchanger	1" G	1" G
10. (M)	Solar probe	1/2" G	1/2" G
11. (N)	Supply solar exchanger	1" G	1" G
12. (O)	Probe heater	1/2" G	1/2" G
13. (P)	Connections	1" 1/2 G	1" 1/2 G
14. (Q)	Connection	1" 1/2 G	1" 1/2 G
15. (R)	Return alternative exchanger	1" G	1" G
17. (T)	Thermometer	1/2" G	1/2" G
19. (V)	Supply alternative exchanger	1" G	1" G
20. (Z)	Coil IN	1" 1/2 G	1" 1/2 G

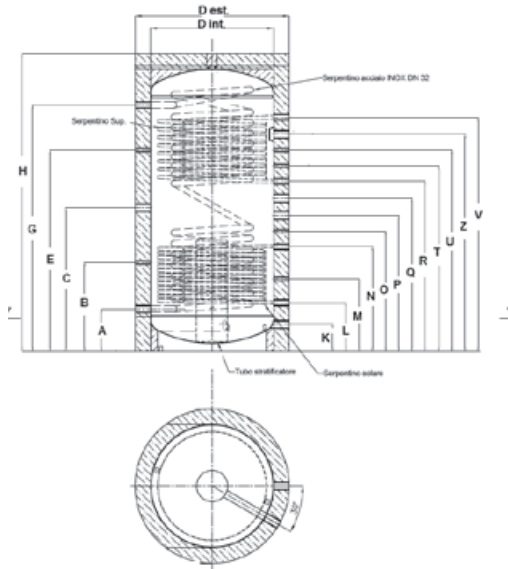

DIMENSIONS (mm)	500-2	800-2	1000-2
A	240	270	270
B	440	570	580
C	820	920	1130
D ext	850	990	990
D int	650	790	790
E	1150	1290	1500
G	1420	1580	1760
H tot	1720	1910	2090
K	150	170	170
L	280	310	310
M	490	465	495
N	640	670	730
O	--	770	840
P	810	870	950
Q	--	980	1060
R	930	1090	1210
S	1050	--	--
T	1170	1190	1330
U	--	1290	1450
V	1290	1500	1680
Z	1400	1390	1520

MODEL		500-2	800-2	1000-2
ERP Class	(F - A+ Class)	C	N.D.	N.D.
Total volume	l	500	800	1000
DHW coil surface	m ²	5,64	5,64	5,64
DHW coil water content	l	35	35	35
Heat exchanger surface	m ²	2,3 / 2,3	2,0 / 3	3,0 / 3,0
Heat exchanger volume	l	12,4 / 12,4	14,9 / 14,9	14,9 / 14,9
Heat exchanger power	kW	68 / 68	60 / 89	89 / 89
Necessary flow heat exchanger	m ³ /h	2,9 / 2,9	2,6 / 3,8	3,8 / 3,8
Water production 80/60°C	m ³ /h	1,7 / 1,7	1,5 / 2,2	2,2 / 2,2
Charge loss heat exchanger (flow 1m ³ /h)	kPa	1,71 / 1,71	1,34 / 2,14	2,14 / 2,14
Water production 80/60°C - 10/45°C	m ³ /h	0,417	0,660	1,230
	kW	17	27	50
Weight	kg	169	217	250
Total heat loss	W	90	117	123
DHW pressure	bar	6	6	6
Max exchanger pressure	bar	10	10	10
Max heating pressure	bar	3	3	3
Max temperature tank	°C	95	95	95
CODE		OYH96AXA	OYH98AXA	OYH99AXA

ECOPUFFER H 500-5000 LARGE CAPACITY BUFFER

ERP



> GENERAL CHARACTERISTICS

ECOPUFFER H is a raw carbon steel tanks S235JR with a storage capacity from 500 to 5000 lt. The thermal insulation is obtained by a coat in Polyester wadding (VLIES) thickness 100mm.

The exterior jacket is made of coupled PVC.

Maximum working pressure 3 bar.

Maximum temperature 95°C

These tanks are used for the storage of non-sanitary water.

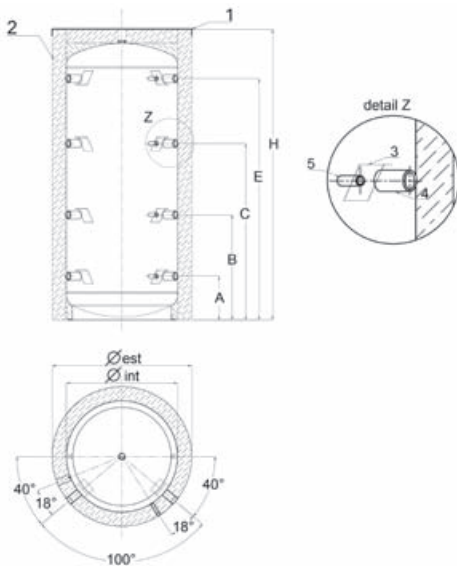

CONNECTIONS	500 / 2000	3000 - 5000
A Connection 1	1" ½ G	2" G
B Connection 2	1" ½ G	2" G
C Connection 3	1" ½ G	2" G
E Connection 4	1" ½ G	2" G
Sensors	½" G	½" G

DIMENSIONS (mm)	500	800	1000	1500	2000	3000	5000
A (soft insulation)	210	260	310	372	328	390	495
B (soft insulation)	605	630	745	817	885	1950	1120
C (soft insulation)	995	1030	1250	1342	1441	1510	1745
E (soft insulation)	1345	1430	1710	1752	1998	1070	2375
A (hard insulation)	235	-	-	-	-	-	-
B (hard insulation)	630	-	-	-	-	-	-
C (hard insulation)	1020	-	-	-	-	-	-
E (hard insulation)	1370	-	-	-	-	-	-

MODEL		500	800	1000	1500	2000	3000	5000
ERP Class	(F - A+ Class)	C	N.D.	N.D.	N.D.	N.D.	N.D.	N.D.
Total volume	l	471	736	888	1474	2012	2673	4978
Heat loss	W	88	111	123	163	173	284	418
External diameter (soft insulation)	mm	850	990	990	1200	1300	1450	1800
Total height (soft insulation)	mm	1640	1750	2050	2150	2480	2515	2895
Max tank pressure	bar	3						
Max tank temperature	°C	95						
Weight	Kg	88	106	133	180	250	320	630
CODE		OYH16AXA	OYH18AXA	OYH19AXA	OYH1BAXA	OYH1CAXA	OYH1DAXA	OYH1GAXA

ECOPUFFER H-1 500-5000 VERTICAL WATER STORAGE WITH COIL

ERP



> GENERAL CHARACTERISTICS

ECOPUFFER H-1 is a raw carbon steel tanks S235JR, equipped with a coil, with a storage capacity from 500 to 5000 lt.

The thermal insulation is obtained by coating in Polyester wadding (VLIES) thickness 100mm.

The exterior jacket is made of coupled PVC.

Maximum working pressure 3 bar

Maximum temperature 95°C

These tanks are used for the storage of non-sanitary water

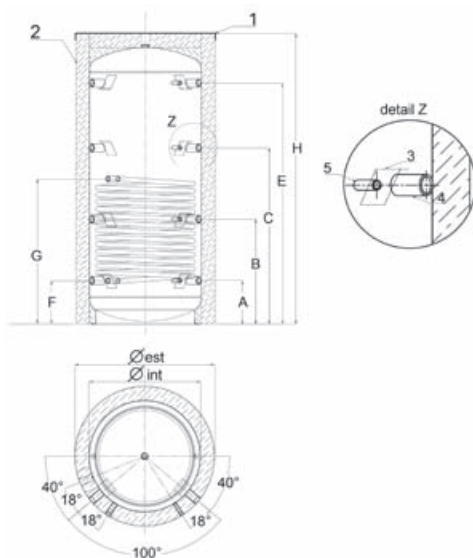

CONNECTIONS	500 / 2000	3000 - 5000
A Connection	1" ½ G	2" G
B Connection	1" ½ G	2" G
C Connection	1" ½ G	2" G
E Connection	1" ½ G	2" G
F Exchanger IN	1" G	1" G
G Exchanger OUT	1" G	1" G
Sensors	½" G	½" G

DIMENSIONS (mm)	500	800	1000	1500	2000	3000	5000
A (soft insulation)	210	260	310	372	328	390	495
B (soft insulation)	605	630	745	817	885	1950	1120
C (soft insulation)	995	1030	1250	1342	1441	1510	1745
E (soft insulation)	1345	1430	1710	1752	1998	1070	2375
F Exchanger IN	210	260	310	372	328	390	495
G Exchanger OUT	1105	930	1030	1172	1131	1140	1265
A (hard insulation)	235	-	-	-	-	-	-
B (hard insulation)	630	-	-	-	-	-	-
C (hard insulation)	1020	-	-	-	-	-	-
E (hard insulation)	1370	-	-	-	-	-	-

MODEL		500-1	800-1	1000-1	1500-1	2000-1	3000-1	5000-1
ERP Class	(F - A+ Class)	C	N.D.	N.D.	N.D.	N.D.	N.D.	N.D.
Total volume	l	471	736	888	1474	2012	2673	4978
Heat loss	W	88	111	123	163	173	284	418
External diameter	mm	850	990	990	1200	1300	1450	1800
Total height	mm	650	790	790	1000	1100	1250	1600
Heat exchanger surface	m²	1,8	2,4	3,0	3,6	4,2	5,0	5,0
Heat exchanger volume	l	11,4	15,2	19,0	22,8	26,6	31,1	31,1
Coil heating capacity	kW	53	72	89	107	125	148	148
Coil DHW production	m³/h	1,3	1,8	2,2	2,6	3,1	3,6	3,6
Water flow on heat exchanger	m³/h	2,3	3,1	3,8	4,6	5,4	6,4	6,4
Water pressure drop on heat exchanger	kPa	1,48	1,88	2,38	2,88	3,37	3,99	3,85
DHW pressure	bar	3						
Max exchanger pressure	bar	3						
Max heating pressure	°C	95						
Max temperature tank	°C	110						
Weight	Kg	88	106	133	180	250	320	630
CODE		OYH66AXA	OYH68AXA	OYH69AXA	OYH6BAXA	OYH6CAXA	OYH6DAXA	OYH6GAXA

NOTES

A series of horizontal dotted lines for writing notes, spanning the width of the page.



■ In accordance with the constant efforts to improve its range of products and thus raise the level of customer satisfaction, the Company stresses that the appearance and/or size, technical specifications and accessories may be subject to variation.

Ferroli spa

37047 San Bonifacio (VR) Italy - Via Ritonda 78/A

tel. +39.045.6139411

fax +39.045.6100233

www.ferroli.com

export@ferroli.com