



Product catalogue

March **2018**

CLIMA&COMFORT | PROFESSIONAL

SUMMARY

Ferrol production plant	4
Laboratory R&D	6
References	8
AIR CONDITIONING	11
HEAT PUMPS	105

> Ferroli production plant

THE PRODUCTION PLANT OF THE INDUSTRIAL AIR CONDITIONING AN AREA OF 20,000 M² AND IS LOCATED IN VILLANOVA, NEAR SAN BONIFACIO (VR) CLOSE TO THE HEAD QUARTERS. RECENT IMPORTANT INVESTMENTS HAVE BEEN MADE TO IMPROVE AND UPGRADE THE PRODUCTION PROCESS STAGES.

A MICRO-FACTORY WITHIN THE MAIN PRODUCTION FACILITIES WITH **LEAN PRODUCTION** KANBAN SYSTEM PRODUCES HIGH SPECIFICATION FAN COIL TERMINALS.



> FAN COIL PRODUCTION

The production process begins with the production of the finned coil in copper and aluminium, complete with a welding and testing line.

The assembly cell (picture opposite) assembles the components such as fan-motor, condensate tray and heat exchanger along with the main structure.

The final assembling and packaging cell assembles the cabinets and all components, such as valves, supplementary trays, and the controls.





fig. a



fig. b

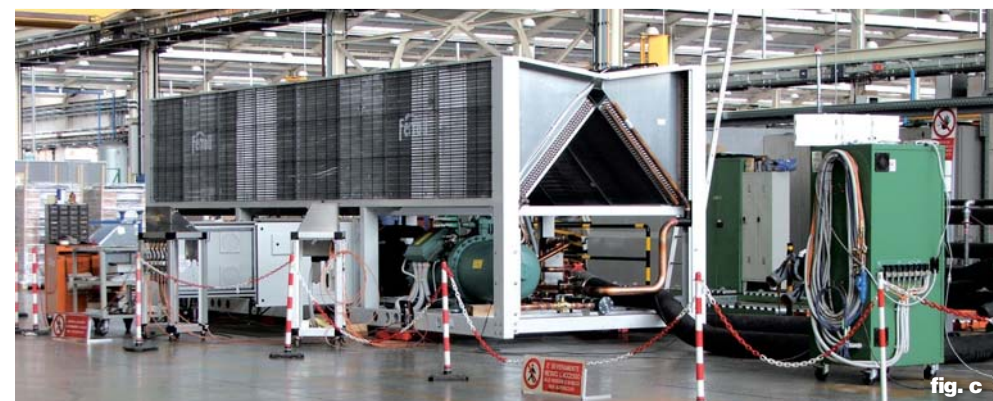

fig. c



fig. d

> ASSEMBLY LINE FOR CHILLERS AND HEAT PUMPS

The different production lines located in the factory are tailored for the manufacturing of equipments according to their type and size. Every unit is assembled with care and 100% verified. It is univocal identified by a serial number.

Test is carried out by skilled and trained staff. It is based on clear operational instructions, in compliance to european rules.

Test results for each machine (operational and performance report, tightness, pressure, electric controls) are automatically stored inside the company's servers.

Charts and reports for monitoring production schedules, efficiency, construction and the safety within the departments are updated and displayed (fig. d) inside the plant are available to all, as well as visiting customers and professionals.

> Laboratory R&D

THE RESEARCH & DEVELOPMENT LABORATORIES ARE THE PRESTIGIOUS AREAS OF FERROLI PRODUCTION FACILITIES. INDIVIDUAL R & D LABORATORIES OPERATING INSIDE THE PRODUCTION PLANT ARE DEDICATED TO INDUSTRIAL AIR CONDITIONING TOTALLING AN AREA OF 1400 M².

ITS MAIN DUTIES INCLUDE DESIGNING PROTOTYPES FOR THE TECHNICAL DEPARTMENT AND CARRYING OUT FUNCTIONAL TESTS IN D.B. AND W.B.

TEMPERATURE CONDITIONS ACCORDING TO CURRENT EUROPEAN STANDARDS.

LABORATORY IS EQUIPPED OF:

> A calibrated-type calorimeter **C1** (with double chamber without cavity separated chambers where losses are taken into account) for checking units up to $P=16.5$ kW and to a temperature of -10°C , equipped inside with an enthalpy tunnel for calculating the performance of internal split or fan coil units up to $Q=1,500$ m³/h, built to AMCA 210 specifications (**fig. a**).

A compensated-type calorimeter **C2**, with a cavity separated chambers, for checking units up to $P=16.5$ kW with the capability of testing units to a temperature of -10°C (**fig. a**).

A semi anechoic chamber **C3** for sound power and pressure tests. The chamber is suitable for units up to $P=50$ kW and therefore for the whole range of terminal units and chillers up to the powers conditions;

C4 climatic chamber, qualified for testing of units up to $P=185$ kW, until -10°C temperature. The said room has been especially studied to perform checks on machines equipped with centrifugal fans or roof-top types (**fig. b**);





fig. b



fig. c

> All the chambers allow our technicians to control cooling only or heat pump units, with heat recovery in the de-superheating phase or total heat recovery and In addition process units for leaving water temperature down to -12°C . The financial investment in R&D in recent years have enabled the production of systems that meet individual market demands needs in terms of performance (efficiency, quiet operation, reliability).

> The most significant and largest financial investment is certainly the climatic chamber C5, which is one of the largest in Italy and able to test units for powers up to 1800 kW (fig. c-d). The total internal volume (approx. 1200 m³) is controlled by a system of water and re circulated air circuits with inverter control and a smart software system enabling testing without personnel for temperatures to -10°C , with the option of dividing the chamber into separate zones for testing two units at the same time under different conditions.

> The steam for test some unit is produced by a boiler at low pressure, specially designed by the industrial heating division technical department.

REFERENCES

ITALY

HOSPITAL AUTHORITIES

Milazzo (ME) RHA + RGA + UTA	Sarcone (BA) RGA	Manduria (TA) RXA + RMA + FAN COIL + TERMOVENTILANTI	ASL di Frosinone (FR) RLA + CENTRALI TRATTAMENTO ARIA
Piemonte (ME) RLA + FAN COIL	S. Anna (CO) UTA	Moscato (TA) RXA + TERMOVENTILANTI	Casa di Cura Columbus (MI) CENTRALI TRATTAMENTO ARIA
S. Filippo Neri Roma RMA + FAN COIL	Belcolle (VT) UTA	S. Vito al Tagliamento (UD) UTA + TERMOVENTILANTI	Istituto Zooprofilattico (SS) RLA + RHA
Militare Celio (RM) UTA + FAN COIL	Maggiore (BO) UTA	Niguarda (MI) TERMOVENTILANTI	Regione Lazio (RM) CENTRALI TRATTAMENTO ARIA
Opera Pia (VB) RMA + FAN COIL	S.Martino (GE) RGA	Maggiore della Carità (NO) UTA + RLA + RGA	Clinica Villa Sandra (RM) CENTRALI TRATTAMENTO ARIA
Cotugno (NA) RGA + UTA + FAN COIL	Barcellona (ME) UTA	Gubbio (PG) RGA + FAN COIL	Casa di Cura S. Lorenzino (FC) RGA
Vecchio Palmanova (UD) FAN COIL	G. Rummo (BN) RGA	Presidio Ospedaliero ASL n. 4 APICELLA (NA) RGA	Laboratorio TUV Scarmagno (TO) RGA + FCS
V. Emanuele Gela (RG) RHA + UTA	Cà Foncello (TV) UTA	Azienda Ospedaliera Senese (SI) RXA	I.P.A.B. Ist. Giovanni XXIII (BO) RHA + CENTRALI TRATTAMENTO ARIA
Borghesiasia (VC) RHV + UTA	Vittorio Emanuele III (CL) UTA	Policlinico di Monza (MI) RGA	Centro Sterilizzazione "Steril Piemonte" (VC) RHV + RLA + CENTRALI TRATTAMEN- TO ARIA
Misericordia (GR) FAN COIL	Vincenzo dell'Erba (BA) RMA + UTA	USL 4 di Prato (PO) CENTRALI TRATTAMENTO ARIA + RGA + VENTILCONVETTORI	Ingegneria Biomedica S. Lucia (NO) RGA + VENTILCONVETTORI
Silvestrini (PG) FAN COIL	Santhià (TO) RLA + FCF		
Villa San Pietro (RM) UTA	Borgomanero (NO) RHA + UTA		
San Bonifacio (VR) UTA	Bambin Gesù Roma UTA + FANCOIL		
C. Poma (MN) FAN COIL	Sandro Pertini (RM) RGA + FAN COIL	USL 13 (BA) CENTRALI TRATTAMENTO ARIA	
Monaldi (NA) RLA + UTA		ASL NAPOLI 2 (NA) CENTRALI TRATTAMENTO ARIA	

SCHOOLS, UNIVERSITIES, LIBRARIES / HOTEL / CATERING

SCHOOLS, UNIVERSITIES, LIBRARIES

Liceo Classico S.M. Legnani (VA) RGA + UTA	IPSIA di Gallarate (VA) UTA	Hotel Baco da Seta (AQ) RGA	CATERING / RESTAURATION Ristorante "Mare Rosso" (MI) HSW
Biblioteca di Palazzo Chigi (RM) FAN COIL	Università di Bari (BA) RGA + UTA	Hotel Torricella (PG) RGA	Cantine le Cionce (GR) RLA
Biblioteca Com. Macomer (SS) ROOF TOP	Università di Salerno (SA) ROOF TOP	Hotel Tilibas (SS) UTA	Cantina Zaccagnini (PE) ROOF TOP
Biblioteca Com. Caserta (CE) RLA	Palazzo Reale (NA) RGC	Hotel Tiberio Palace (NA) RHA + RHV + FCF + UTA + UT REC	Castello di Radda (SI) UTA
Università Magna Grecia (CZ) UTA	Politecnico di Bari UTA	Hotel Incanto (PI) RGA	Ristorante Santo Spirito (SA) RLA + UTA
	Campus Universitario (PI) UTA + FAN COIL	Hotel Hilton (MT) UT REC + TCX	Villaggio turistico Casalvelino (SA) RLA + FAN COIL
	HOTEL / HOTEL Hotel San Marco (VR) UTA	Residence "La Giurlita" (LE) RMA + FCF + TCX	Best Western Soave Hotel (VR) RLA + FAN COIL + UT REC
	Hotel Mediterraneo (RG) RLA		

BANKS / OFFICES / SALES OUTLETS

BANKS

Monte dei Paschi di Siena UTA + TERMOVENTILANTI	OFFICES Regione Puglia (LE) RGA	Direzione compartimentale Ferrovie Italiane (AN) FCF + FCS	Carrefour (NO) RLA
CMP - Poste Italiane (PG) RLA + RGA + RMA	Telecom S.P.A. (AQ) FAN COIL	Fiat Group - Ingest Facility (TO) RGA + RLA + UTA	Brico Center (PV) ROOF TOP
Poste Italiane CMP (AN) UT REC	Telecom S.p.A. (RM) FAN COIL	Autostrade Italiane Direzione tronco 2 (MI) UTA	Carrefour (CE) CX + FAN COIL
Poste Italiane (RM) UTA	Pirelli R.E. (TO) RVW		Concessionaria AUDI (VC) RGA
Banca Finconsumo RSA + RPC + FAN COIL	Olivetti Multiservices SpA (TO) UTA	SALES OUTLETS Luisa Spagnoli S.P.A. (PG) POLAR	Concessionaria AUDI (NO) RLA
Banca d'Italia (BS) RXA	Sede Municipale S. Teresa di Riva (ME) RGA	LIDL Cairo Montenotte (SV) RGA	Caliese Centrum (CE) RLA + FTP + MERCURY ST + VEC

REFERENCES

MILITARY SECTOR / SECTEUR MILITAIRE

MILITARY SECTOR

Caserma Guardia di Finanza
"Cefalonia Corfù" (PG)

FCF

Scuola di Polizia Ministero
Infrastrutture (RM)

RFA + RMA + RGA + RLA

Esercito Italiano (RM)

CARRELLABILI

Comando Guardia di Finanza
(TP)

RLA

Caserma U. Polonio (GO)

RGA + FAN COIL + UTA

Caserma Guardia di Finanza
(RA)

RGA + FCS

Arsenale di Taranto (TA)

RHA + FAN COIL + UTA

Scuola Militare di Cavalleria
(TO)

CENTRALI TRATTAMENTO ARIA

Caserma Carabinieri
S. Bonifacio (VR)

RGA + RMA

LARGE AREAS

Centro Congressi (AR)

UTA + RLA + RGA

Museo delle Scienze Naturali
(BN)

RGA + FAN COIL

Piscina Intercomunale Fucecchio
(FI)

UTA

Museo Etnografico Caravel
(AO)

RGA + UTA

Museo Comunale (RN)

RLA + UTA

Centro Comm.le Ortuso (RC)

UTA

Centro Comm.le Corolla
(ME)

UTA

De Martini Shipping (GE)

UTA

Teatro San Carlo (NA)

UTA

Teatro Diana (SA)

RLA

Mercato Tartini (BO)

UTA

Multisala Impero (VA)

ROOF TOP

Sala Bingo di Gallipoli (LE)

ROOF TOP

Palazzo INAIL (VC)

RGA

EUROMA (RM)

RHV

Auditorium di Mantova (MN)

RGA + UTA

Conservatorio Musicale (SA)

RMA + FCS

Centro Natatorio (MN)

RLA + UTA

CUS Campo Hockey (PI)

UTA

Palacilento (SA)

RHA + UTA

INDUSTRIES / INDUSTRIE

INDUSTRIES

Stabilimento Versace S.P.A.
(NO)

RHA

Stab. Artema S.P.A. Zegna
(BI)

RGA

Stabilimento AIA (VR)

RHA

Gruppo Fendi S.P.A. (MI)

UTA

Stab. Doimo City Line (TV)

RLA

Stabilimento LIOLà Spa (NO)

RGA

Stab. TYCO VALVES (PC)

RGA

Riseria Stroppiana (VC)

RLA

Finmeccanica (RM)

RGA

Stabilimento Ferrero (CN)

UTA + RLA

Concerie Settebello (PI)

RHA + RGA

Stabilimento Unoaerre (AR)

RHV + UTA

Stabilimento Ericsson (NA)

UTA + FAN COIL

Stabilimento Ansaldo (TO)

RGA + UTA + FAN COIL

Cantiere S. Paolo (BA)

RGA + FAN COIL + UT REC

Stab. Missano S.p.A. (SA)

RLA + RGA + UTA

AIRPORTS

Militare Base Nato (BR)

RLA

Fiumicino L. da Vinci (RM)

UTA

Militare "F. Baracca" (RM)

RGA

Militare Pratica di Mare (RM)

RLA + UTA + FAN COIL



OSPEDALE DI SAN BONIFACIO (VR)



TIBERIO PALACE, HOTEL & CONFERENCE CENTER - NAPOLI



TEATRO SAN CARLO - NAPOLI



PALACILENTO - SALERNO

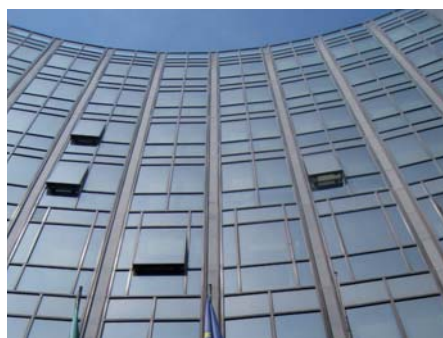

SEDE FINMECCANICA - ROMA



COMPLEJO HOTELERO TERRALTA - ALICANTE, SPAGNA

REFERENCES

SPAIN

Hospital de Alta Resolución de Loja
Hospital de Sagrado Corazón
Hospital Meixorio de Vigo
Hospital de Enfermedades Raras
Hospital Benito Menni
Hospital Xanit
Centro Salud Manzanares
Clínica Cefer

Rehabilitación oficinas
Mercado Municipal
Museo de Calahorra
Colegio Corazonistas
Edificio Presidencia de la Generalitat
Edificio banco España
Polideportivo Parque Coimbra
Polideportivo Siec

Facultad de Derecho
Centro Cultural Bembrive
Edificio Banco Espana
Ayuntamiento
Complejo Hotelero Terralta
Hotel Carlton
Hotel Fuente Las Piedras
Hotel San Francisco
Hotel El Espinar
Hotel Acosta

Hotel Parador
Hotel Villa de Benavente
Hotel Meridional
Hotel Benidorm
Hotel Balneario de Orio
Hotel Abando
Juzgados de Olot

ROMANIA

Rsi Electro Office Building
Office Building Vitan
Office Building Pipera
Hotel Floreasca
Hotel Rodna
Hotel Maxim
Ness Service - Dvd Factory
Sediu Galmopan

Sediu Arabesque
Moticica Grup
Mmm Automotive
Climatherm Center
Frigoglass Romania
Teo Center
Amma Print
Rh Printing

Reamedia
S.C.Delphi Romania S.R.L.
Club Office
Cazino
Aeroport SIBIU
ODS Business Service-DVD
Manoil Mall
Bazin OLIMPIC

Sala Sporturilor
Stabilus
Stella Building/ Jules Verne
Sempo SA
Loial

RUSSIA & REPUBLIC OF BELARUS

RUSSIA

Commercial Center "ARMA-DA"
Moscow,
RHV + VHF3
"Kuba Commercial Center"
Chelabinsk,
RHV + FCS
Medical Center of Tamographics
Chelabinsk,
RGA + FCS + TOP FAN
Commercial center
"Moscow prospect",
RGA + TOP FAN VB-M + VHF3, RHV
"SBER-BANK Russia" Moscow office.
Moscow,
RGA + CMA + TOP FAN
Bank "URASLIV" Moscow,
Russia
RGA

Factory of Technical line production
Frazevo,
RGA
JEWELLER Department store
Krasnodar,
RGA + TOP FAN
"Kvaevitskiy Museum" Krasnodar,
RGA + TOP FAN
"Medical center branch" Moscow,
RGA + FCP
Business Hotel – Krasnodar,
RGA + RLA
"Historical – Archeological Museum-Felizina"
FCS

REPUBLIC OF BELARUS

The Skating Ring "Ice Palace"
Baranovichi,
Republican theoretical and practical
Center "Mother and Child"
Minsk,
9- th municipal clinical hospital
Minsk,
Research and Production Corporation "Integral" Minsk,
Business Center "BME BUSINESS CENTER" Minsk,
Republican theoretical and practical

Center of oncology and medical radiology Minsk,
BMW offices and service center
Minsk,
Business Center "Europe" Minsk,
Unitary enterprise
"Mucipal Bathhouses" Minsk,
BELMICROSYSTEMS RESEARCH & DESIGN CENTER Minsk,
Organizations of the NASB
Department of Chemical and Earth Sciences Minsk

TURKEY & REST OF THE WORLD

TURKEY

Turkmenistan Projeleri
Bs Press
Cemdag Plastik
Plasko Plastik
Izmit Ticaret Odasi
Izmit Skoda Plaza
Lady Diana Hotel
Lidersan
Samandira

Aksoy Plaza
Nizip Diyyaliliz Merkezi
Yasam Hastanesi
Van Hastenesi
Corlu Belediye Binasi
Gebze Oteli
Kultur Merkezi
Unsal Radyator Fabrikasi

REST OF THE WORLD

Centro Commerciale FC BIH
Dedinje 3.Objekat
New Nork Shopping Center
Srbija Beograd, Dedinje
Ceek

AIR CONDITIONING

> Product range Air Conditioning.....	12
> Chillers.....	14
RMA ² HE.....	14
RGA.....	18
RGA HE.....	22
RLA.....	26
RLA HE.....	30
RMP ² HE.....	34
RGC.....	38
RGC HE.....	42
RGW.....	46
> Condensing unit.....	50
CMA ² - CMA ² HE.....	50
CMP ² - CMP ² HE.....	54
CGA.....	58
CGA HE.....	62
CGC.....	66
CGC HE.....	70
EGW.....	74
> Fan coil units.....	78
TOP FAN ^{PLUS}	80
JOLLY PLUS 2.....	84
SUPER FAN.....	88
FCM.....	90
MERCURY ST.....	92
> Air handling units.....	94
FAHU.....	94
FTP.....	94
> Heat recovery units.....	96
UT REC micro E.....	96
UT REC +.....	98
UT REC C+.....	100
UT REC R+.....	102

Product range AIR CONDITIONING

AIR COOLED WATER CHILLER WITH AXIAL FANS

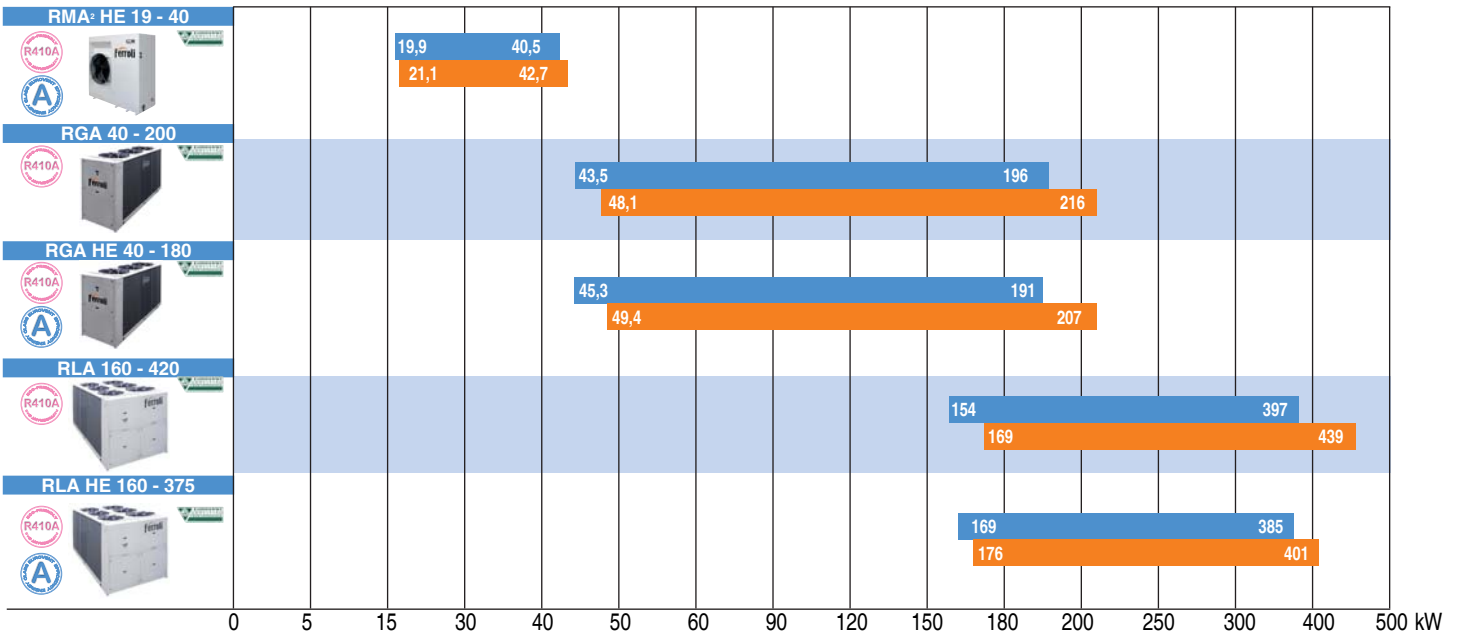

AIR COOLED WATER CHILLER WITH CENTRIFUGAL FANS

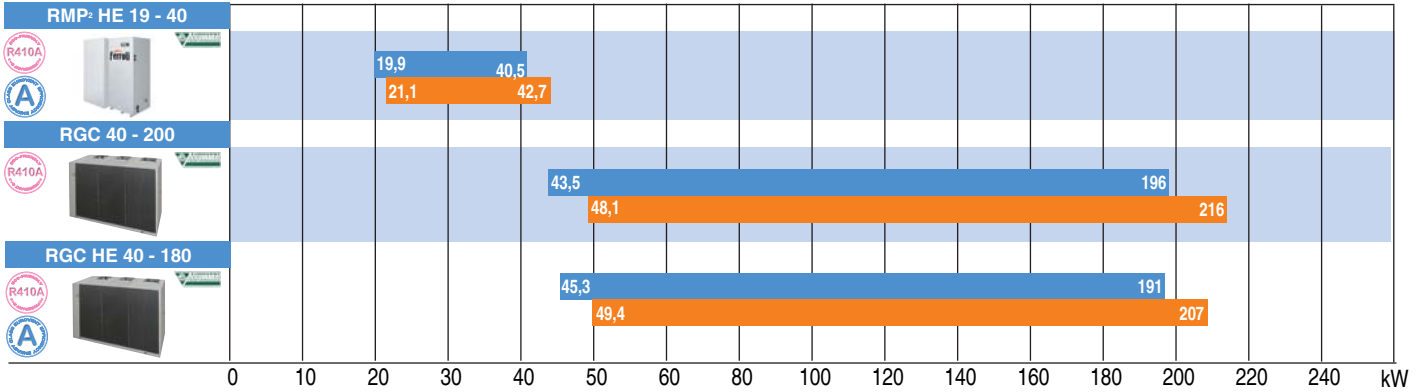

WATER COOLED WATER CHILLERS

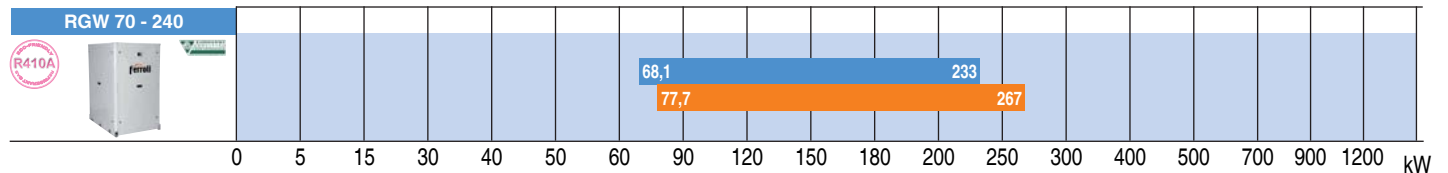

CONDENSERLESS UNITS FOR INDOOR INSTALLATION

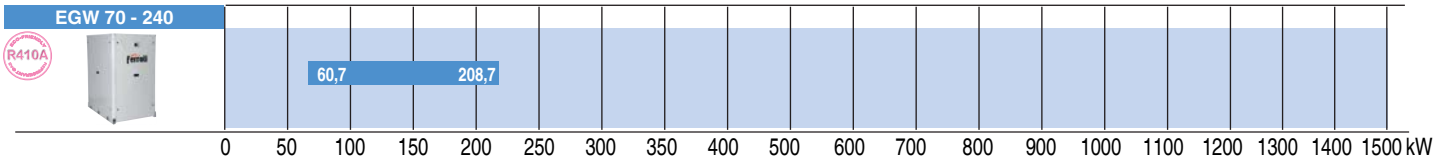

AIR HANDLING UNITS

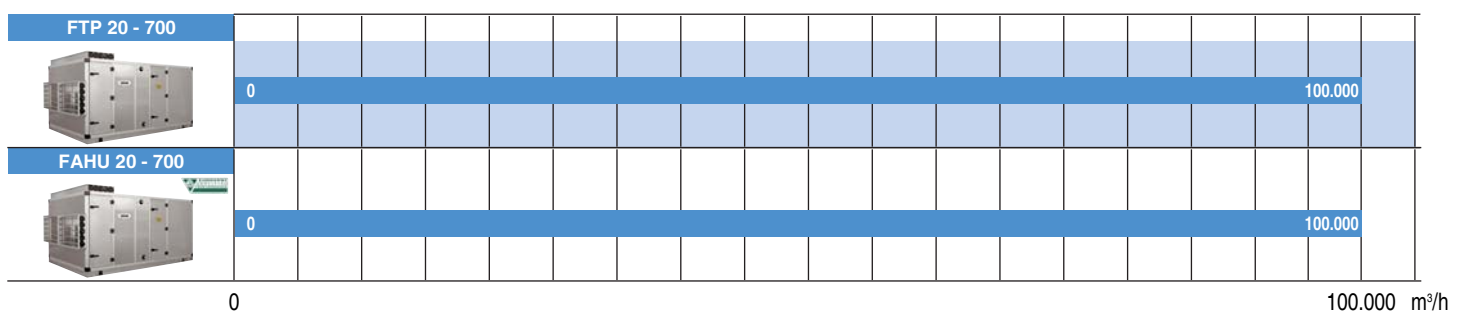

The list of certified products is available on the website www.eurovent-certification.com.
The Eurovent certification program LCP-HP shall apply to air cooled water chillers with nominal cooling capacity up to 600 kW and water cooled chillers with nominal cooling capacity up to 1500 kW.

DIRECT EXPANSION CONDENSING UNITS

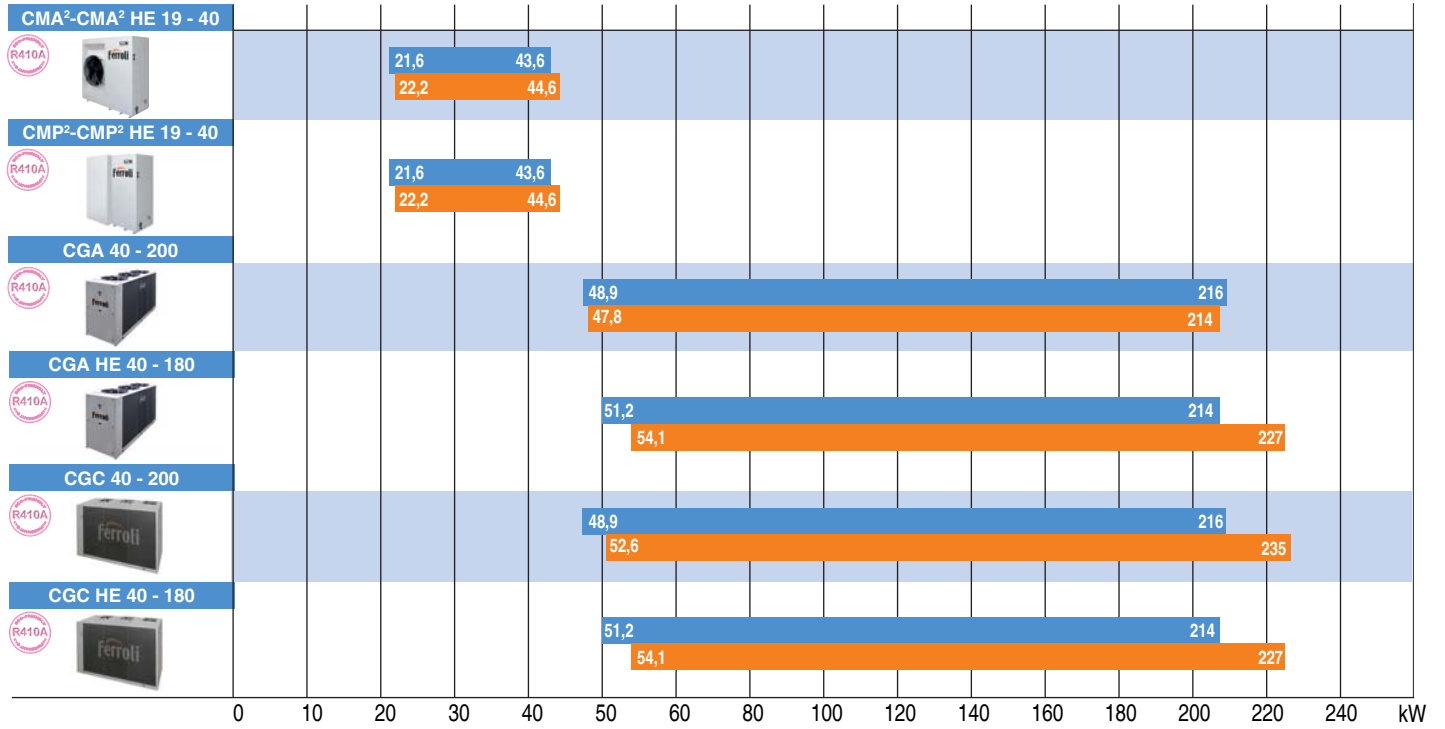

FAN COIL UNITS

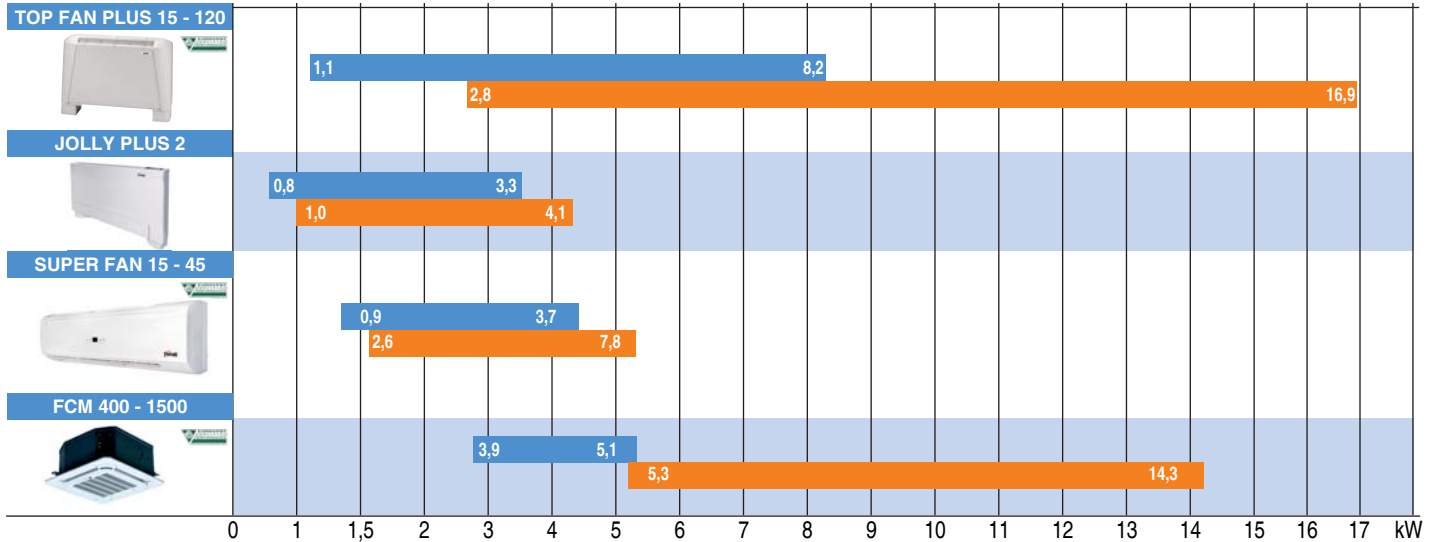

DUCTED FAN COIL UNITS

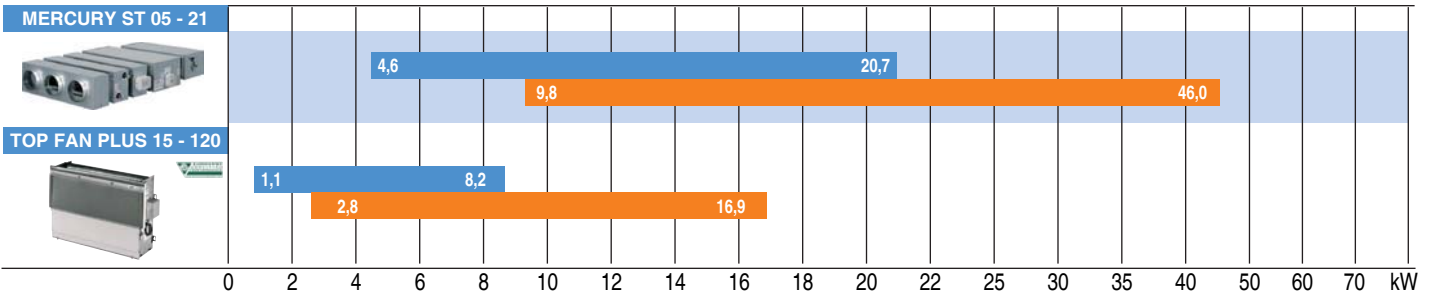

HEAT RECOVERY UNITS

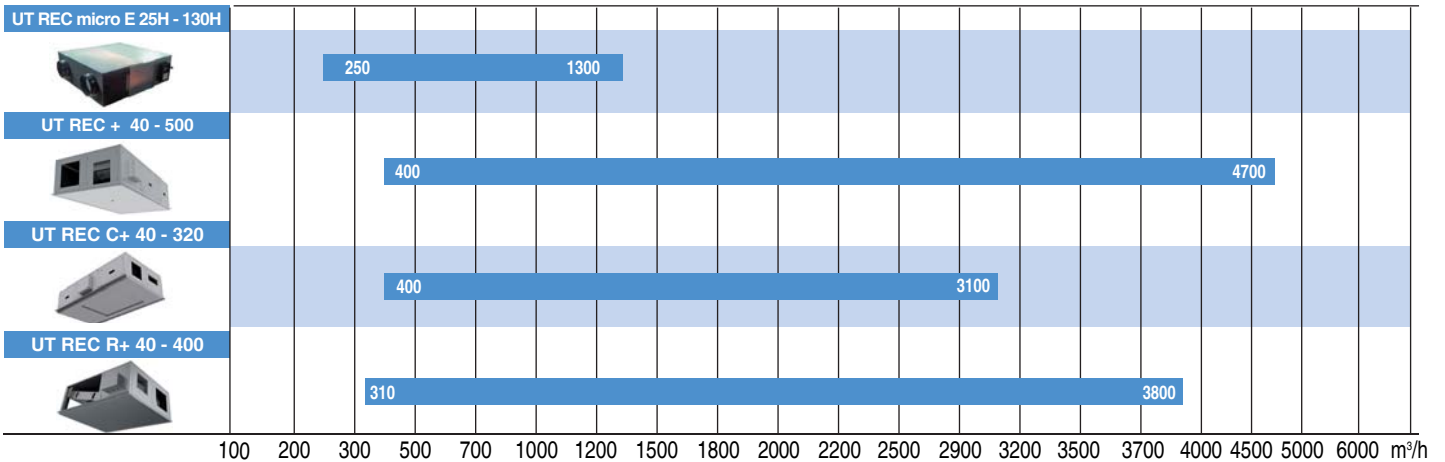

> RMA² HE

AIR-WATER HEAT PUMPS FOR OUTDOOR INSTALLATION



Efficiency capacity in heating mode - Heat pump low temperature - Medium temperature level

Acoustic setting up	19.1	22.1	26.1	30.1	35.1	40.1
AB	A+	A+	A+	A	A+	A+
AS	A+	A+	A+	A	A+	A+

NOTA: Declared according to European regulation 811/2013. The values are referred to units without options and accessories.

Available range

Unit type

IP	Heat pump (reversible on the refrigerant side)
BP	Heat pump Brine (reversible on the refrigerant side)

Versions

VB	Base Version
VP	Pump version
VA	Tank version

Acoustic setting up

AB	Base setting up
AS	Low noise setting up

Unit description

This series of air-water heat pumps satisfies the cooling and heating requirements of residential plants of small and medium size.

All the units are suitable for outdoor installation and can be applied to fan coil plants, radiant floor plants and high efficiency radiators plants.

The refrigerant circuit, contained in a compartment protected from the air flow to simplify the maintenance operations, is equipped with scroll compressor mounted on damper supports, brazed plate heat exchanger, thermostatic expansion valve, reverse cycle valve, axial fans with safety protection grilles, finned coil made of cop-

per pipes and aluminium louvered fins. The circuit is protected by high and low pressure switches and differential pressure switch on the plate heat exchanger.

The plate heat exchanger and all the hydraulic pipes are thermally insulated in order to avoid condensate generation and to reduce thermal losses.

All the units can be equipped with variable speed fans control that allows the units to operate with low outdoor temperatures in cooling and high outdoor temperature in heating and permits to reduce noise emissions in such operating conditions.

The low noise acoustic setting up (AS) is obtained, starting from the base setting up (AB), reducing the rotational speed of the fans and mounting sound jackets on the compressors.

All the units are provided with a phase presence and correct sequence controller device.

All the units are accurately built and individually tested in the factory. Only electric and hydraulic connections are required for installation.

Options

Storing and pumping module

- not present (VB - base version)
- standard, high head or modulating pump (VP - pump version)
- tank and standard, high head or modulating pump (VA - tank version)

Integrative electrical heaters

- not present
- standard in the tank

Compressor starting

- standard (contactors)
- soft starter

Fans control

- on-off control
- modulating control (condensation / evaporation control)

Electrical loads protection

- fuses
- thermal magnetic circuit breakers

Compressor power factor correction

Accessories

Rubber vibration dampers

Coil protection grille

Remote control

Modbus serial interface on RS485

Programmer clock

Phase sequence and voltage controller

Water flow switch

Manometer

Oil crankcase electrical heater

Pressure transducer

Coil protection kit for shipment

Outdoor air sensor

NET NOMINAL performances - Standard plants - EUROVENT certified data

IP	Allestimento Base (AB)	19.1	22.1	26.1	30.1	35.1	40.1	
A35W7	Cooling capacity	19,9	22,3	25,9	30,9	34,8	40,5	kW
	Power input	6,42	7,17	8,25	9,96	11,20	12,95	kW
	EER	3,10	3,11	3,14	3,10	3,11	3,13	W/W
	SEER	3,44	3,47	3,59	3,36	3,36	3,42	W/W
	Water flow rate	3442	3859	4478	5337	6020	7008	l/h
	Pressure drops	26	24	23	27	28	26	kPa
A7W45	Heating capacity	21,1	24,0	27,8	32,3	37,0	42,7	kW
	Power input	6,42	7,14	8,25	10,01	11,21	12,83	kW
	COP	3,29	3,36	3,37	3,22	3,29	3,33	W/W
	Water flow rate	3612	4096	4763	5517	6320	7310	l/h
	Pressure drops	29	27	26	29	31	28	kPa
IP	Allestimento Silenziato (AS)	19.1	22.1	26.1	30.1	35.1	40.1	
A35W7	Cooling capacity	19,1	21,4	24,9	29,7	33,5	39,0	kW
	Power input	6,91	7,74	8,91	10,75	12,06	13,74	kW
	EER	2,76	2,77	2,79	2,76	2,77	2,84	W/W
	SEER	3,20	3,23	3,31	3,21	3,21	3,25	W/W
	Water flow rate	3302	3700	4303	5129	5785	6748	l/h
	Pressure drops	24	22	21	25	26	24	kPa
A7W45	Heating capacity	20,1	22,9	26,6	31,0	35,2	40,8	kW
	Power input	6,23	6,90	8,00	9,70	10,87	12,42	kW
	COP	3,22	3,32	3,32	3,20	3,24	3,28	W/W
	Water flow rate	3422	3902	4533	5261	6016	6963	l/h
	Pressure drops	26	25	23	26	28	26	kPa

The values are referred to units without options and accessories.

Data declared according to **EN 14511**:

EER (Energy Efficiency Ratio) = ratio of the total cooling capacity to the effective power input of the unit

COP (Coefficient Of Performance) = ratio of the total heating capacity to the effective power input of the unit

SEER (Seasonal Energy Efficiency Ratio) dichiarato secondo EN 14825

A35W7 = source : air in 35°C d.b. / plant : water in 12°C out 7°C

A35W18 = source : air in 35°C d.b. / plant : water in 23°C out 18°C

A7W45 = source : air in 7°C d.b. 6°C w.b. / plant : water in 40°C out 45°C

A7W35 = source : air in 7°C d.b. 6°C w.b. / plant : water in 30°C out 35°C

Acoustic performances

Base setting up (AB)	19.1	22.1	26.1	30.1	35.1	40.1	
Sound power level ^(E)	77	77	78	81	82	82	dB(A)
Sound pressure level at 1 meter	61	62	62	65	66	66	dB(A)
Sound pressure level at 5 meters	51	51	52	55	55	56	dB(A)
Sound pressure level at 10 meters	46	46	47	50	50	50	dB(A)
Low noise setting up (AS)	19.1	22.1	26.1	30.1	35.1	40.1	
Sound power level ^(E)	74	74	75	78	79	79	dB(A)
Sound pressure level at 1 meter	58	59	59	62	63	63	dB(A)
Sound pressure level at 5 meters	48	48	49	52	53	53	dB(A)
Sound pressure level at 10 meters	43	43	44	47	48	48	dB(A)

(E): EUROVENT certified data

The acoustic performances are referred to units operating in cooling mode at nominal conditions A35W7.

Unit placed in free field on reflecting surface (directional factor equal to 2).

The sound power level is measured according to ISO 9614 standard.

The sound pressure level is calculated according to ISO 3744 and is referred to a distance of 1/5/10 metres from the external surface of the unit.

Technical data

Unità	19.1	22.1	26.1	30.1	35.1	40.1	
Power supply	400 - 3+N - 50						V-ph-Hz
Compressor type	scroll						-
N° compressors / N° refrigerant circuits	1 / 1						n°
Plant side heat exchanger type	stainless steel brazed plates						-
Source side heat exchanger type	finned coil						-
Fans type	axial						-
N° fans	1						n°
Tank volume	85						l
Hydraulic fittings	1"1/4 GAS						-

Electrical data

Standard unit	19.1	22.1	26.1	30.1	35.1	40.1	
FLA - Full load current at maximum tolerated conditions	15,8	17,6	19,1	24,4	26,8	30,8	A
FLI - Full load power input at maximum tolerated conditions	9,2	10,7	12,0	14,6	16,1	18,4	kW
MIC - Maximum instantaneous current of the unit	106	116	129	156	160	191	A
MIC SS - Maximum instantaneous current of the unit with soft starter options	61	67	74	85	87	106	A
Unit with standard modulating pump	19.1	22.1	26.1	30.1	35.1	40.1	
FLA - Full load current at maximum tolerated conditions	17,3	19,1	20,6	26,0	28,4	32,4	A
FLI - Full load power input at maximum tolerated conditions	9,8	11,3	12,6	15,4	16,9	19,2	kW
MIC - Maximum instantaneous current of the unit	107	117	130	158	162	193	A
MIC SS - Maximum instantaneous current of the unit with soft starter options	62	68	76	86	89	107	A
Unit with high head modulating pump	19.1	22.1	26.1	30.1	35.1	40.1	
FLA - Full load current at maximum tolerated conditions	17,5	19,3	20,8	27,4	29,8	33,8	A
FLI - Full load power input at maximum tolerated conditions	10,1	11,5	12,9	16,2	17,7	20,0	kW
MIC - Maximum instantaneous current of the unit	108	118	131	159	163	194	A
MIC SS - Maximum instantaneous current of the unit with soft starter options	62	68	76	88	90	109	A

Operating range

Temperatura	Unit type	Cooling		Heating		
		min	max	min	max	
Outdoor air inlet temperature	IP, BP	-10*	50	-15	42	(°C)
Water outlet temperature	IP	5	25	30	55	(°C)
Water outlet temperature	BP	-12	5	30	55	(°C)

* with fans modulating control option (condensation / evaporation control)

CONTROL SYSTEM

The unit is managed by a microprocessor controller to which, through a wiring board, all the electrical loads and the control devices are connected. The user interface is realized by a display and four buttons that allow to view and, if necessary, modify all the operating parameters of the unit. It's available, as an accessory, a remote control that reports all the functionalities of the user interface placed on the unit.

The main functions available are :

- water temperature management (through set point adjustment)
- adaptive function
- climatic control in heating and in cooling mode, automatic set point adjustment according to outdoor air temperature (if present "outdoor air sensor" accessory)
- dynamic defrost cycle management according to outdoor air temperature (if present "outdoor air sensor" accessory)
- alarm memory management and diagnostic

- fans management by means of continuous rotational speed control
- pump management
- integrative electrical heaters management in heating mode
- compressor and pump operating hours recording
- serial communication through Modbus protocol
- remote stand by
- remote cooling-heating
- general alarm digital output



DIMENSIONS AND MINIMUM OPERATING AREA

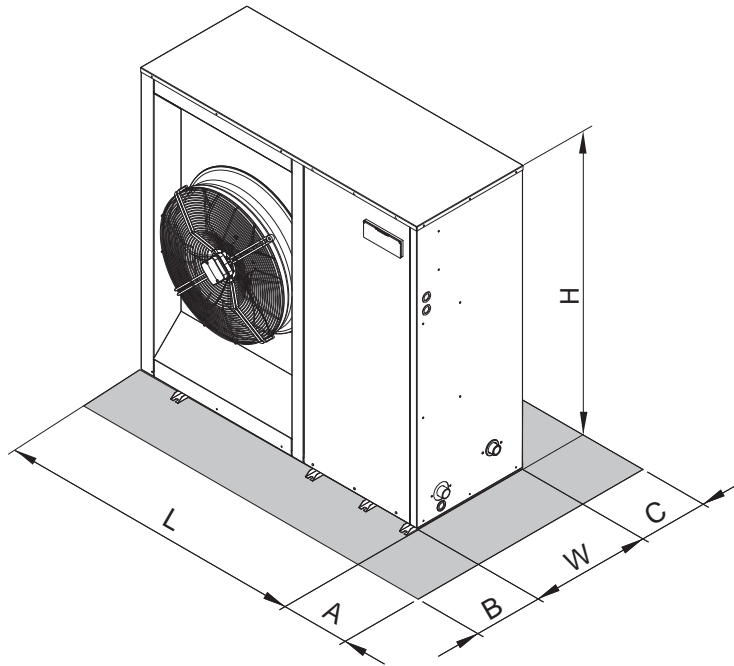

	19.1	22.1	26.1	30.1	35.1	40.1	
L		1494			1704		mm
W		576			576		mm
H		1453			1453		mm
A		400			400		mm
B		600			600		mm
C		200			200		mm
Maximum weight operation (VA Tank version)	364	367	391	412	438	440	kg

> RGA

AIR-WATER CHILLERS AND HEAT PUMPS FOR OUTDOOR INSTALLATION



Efficiency capacity in heating mode - Heat pump low temperature - Medium temperature level

Acoustic setting up	40.2	50.2	60.2	70.2	80.2
AB	A+	A+	A+	A+	A+
AS	A+	A+	A+	A+	A+
AX	A+	A+	A+	A+	A+

NOTA: Declared according to European regulation 811/2013. The values are referred to units without options and accessories.

Available range

Unit type

IR	Chiller
IP	Heat pump (reversible on the refrigerant side)
BR	Chiller Brine
BP	Heat pump Brine (reversible on the refrigerant side)

Version

VB	Base version
VD	Desuperheater version
VR	Total recovery version

Acoustic setting up

AB	Base setting up
AS	Low noise setting up
AX	eXtra low noise setting up

Source temperature level

M	Medium temperature level
A	High temperature level

Unit description

This series of air-water chillers and heat pumps satisfies the cooling and heating requirements of residential plants of medium size.

All the units are suitable for outdoor installation and can be applied to fan coil plants, radiant floor plants and high efficiency radiators plants.

The refrigerant circuit, contained in a compartment protected from the air flow to simplify the maintenance operations, is equipped with scroll compressors mounted on damper supports, brazed plate heat exchanger, thermostatic expansion valve (standard for IR) or electronic expansion valve (standard for IP / option for IR),

reverse cycle valve, dehydrator filter, axial fans with safety protection grilles, finned coil made of copper pipes and aluminium louvered fins with subcooling section. The circuit is protected by a safety gas valve, high and low pressure switches and differential pressure switch on the plate heat exchanger. The plate heat exchanger and all the hydraulic pipes are thermally insulated in order to avoid condensate generation and to reduce thermal losses.

All the units can be equipped with variable speed fans control that allows the units to operate with low outdoor temperatures in cooling and high outdoor temperature in heating and permits to reduce noise emissions in such operating conditions.

The low noise acoustic setting up (AS) is obtained, starting from the base setting up (AB), reducing the rotational speed of the fans and mounting sound jackets on the compressors and the technical compartment is clad with soundproofing material of suitable thickness.

The eXtra low noise acoustic setting up (AX) is obtained, starting from the low noise setting up (AS), further reducing the rotational speed of the fans and using finned coil with bigger surface.

All the units are supplied with a management and control electrical panel containing general switch, phase presence and correct sequence controller, microprocessor controller with display and all the other electrical components with IP54 minimum protection degree.

All the units are accurately built and individually tested in the factory. Only electric and hydraulic connections are required for installation.

Options

Storing and pumping module available in the configurations :

- Storage tank arranged as buffer on the flow or as primary-secondary buffer
- 1 or 2 pumps
- standard or high head pump
- modulating pump

Expansion valve

- thermostatic
- electronic (standard for IP)

Compressor starting

- standard (contactors)
- soft starter

Fans control

- on-off control
- modulating control (condensation / evaporation control)

Compressor power factor correction

Electrical load protection

- fuses
- thermal magnetic circuit breakers

Coil condensate tray

Accessories

Rubber vibration dampers

Spring vibration dampers

Coil protection grilles

Tank antifreeze electrical heater

Remote control

Modbus serial interface on RS485

Programmer clock

Phase sequence and voltage controller

Low temperature kit (standard for IP)

High and low pressure gauges

High temperature thermostat

Outdoor air sensor

Water flow switch

Victaulic hydraulic fittings

NET NOMINAL performances - Standard plants - EUROVENT certified data

IR	Base setting up (AB)	40.2	50.2	60.2	70.2	80.2	90.2	100.2	115.2	130.2	145.2	160.2	180.2	200.2	
A35W7	Cooling capacity	45,0	53,0	58,1	68,2	78,1	90,3	101	111	125	142	157	179	198	kW
	Power input	15,7	18,8	20,8	24,1	28,0	32,5	35,9	39,9	45,1	51,5	57,1	64,6	71,6	kW
	EER	2,87	2,82	2,79	2,83	2,79	2,78	2,81	2,78	2,77	2,76	2,75	2,77	2,77	W/W
	SEER*	3,85	3,86	3,84	3,86	3,88	3,85	3,83	3,85	3,86	3,83	3,85	3,87	3,84	W/W
	Water flow rate	2,16	2,56	2,80	3,29	3,76	4,35	4,87	5,35	6,02	6,83	7,55	8,60	9,56	l/s
	Pressure drops	40	56	55	51	50	48	46	44	48	47	48	48	50	kPa
IR	Low noise setting up (AS)	40.2	50.2	60.2	70.2	80.2	90.2	100.2	115.2	130.2	145.2	160.2	180.2	200.2	
A35W7	Cooling capacity	43,6	51,5	56,3	66,2	75,7	87,6	97,8	108	121	138	152	174	193	kW
	Power input	16,3	19,4	21,6	24,9	29,2	33,7	37,3	41,4	46,8	53,4	59,2	67,0	74,3	kW
	EER	2,67	2,65	2,61	2,66	2,59	2,60	2,62	2,61	2,59	2,58	2,57	2,60	2,60	W/W
	SEER	3,80	3,81	3,80	3,81	3,83	3,81	3,80	3,80	3,80	3,80	3,80	3,81	3,80	W/W
	Water flow rate	2,10	2,48	2,71	3,19	3,65	4,21	4,71	5,21	5,83	6,64	7,31	8,36	9,27	l/s
	Pressure drops	38	53	52	48	47	45	43	42	45	44	45	45	47	kPa
IR	eXtra low noise setting up (AX)	40.2	50.2	60.2	70.2	80.2	90.2	100.2	115.2	130.2	145.2	160.2	180.2	200.2	
A35W7	Cooling capacity	42,7	50,3	55,1	64,7	74,0	85,6	95,6	105	118	134	149	169	188	kW
	Power input	16,3	19,8	22,1	25,4	29,9	32,8	38,3	42,6	48,1	54,3	60,3	68,8	76,2	kW
	EER	2,62	2,54	2,49	2,55	2,47	2,61	2,50	2,46	2,45	2,47	2,47	2,46	2,47	W/W
	SEER	3,81	3,84	3,82	3,83	3,85	3,82	3,82	3,83	3,84	3,82	3,82	3,85	3,82	W/W
	Water flow rate	2,05	2,42	2,65	3,12	3,56	4,12	4,60	5,06	5,69	6,45	7,17	8,12	9,03	l/s
	Pressure drops	36	50	49	46	45	43	41	39	43	42	43	43	45	kPa
IP	Base setting up (AB)	40.2	50.2	60.2	70.2	80.2	90.2	100.2	115.2	130.2	145.2	160.2	180.2	200.2	
A35W7	Cooling capacity	43,5	52,4	57,0	66,7	73,6	88,5	98	109	121	137	153	177	196	kW
	Power input	15,5	19,0	20,7	24,1	27,0	32,3	35,7	39,8	44,5	50,3	56,3	63,5	71,2	kW
	EER	2,81	2,76	2,75	2,77	2,73	2,74	2,75	2,74	2,72	2,72	2,72	2,79	2,75	W/W
	SEER	3,53	3,60	3,46	3,57	3,66	3,45	3,44	3,46	3,50	3,47	3,53	3,50	3,52	W/W
	Water flow rate	2,09	2,53	2,75	3,21	3,54	4,26	4,73	5,26	5,83	6,59	7,36	8,50	9,46	l/s
	Pressure drops	37	55	53	49	44	46	43	43	45	44	46	47	49	kPa
A7W45	Heating capacity	48,1	58,1	63,2	74,5	83,0	99,6	110	125	136	154	173	197	216	kW
	Power input	15,6	19,1	20,9	24,4	27,6	33,5	35,9	41,1	44,9	51,8	56,9	65,1	71,7	kW
	COP	3,08	3,04	3,02	3,05	3,01	2,97	3,06	3,04	3,03	2,97	3,04	3,03	3,01	W/W
	Water flow rate	2,28	2,75	2,99	3,53	3,93	4,72	5,21	5,92	6,45	7,31	8,17	9,32	10,2	l/s
	Pressure drops	45	65	63	59	55	57	53	54	55	54	56	56	57	kPa
IP	Low noise setting up (AS)	40.2	50.2	60.2	70.2	80.2	90.2	100.2	115.2	130.2	145.2	160.2	180.2	200.2	
A35W7	Cooling capacity	41,8	50,4	54,8	64,0	70,6	85,0	94,4	105	116	131	147	170	189	kW
	Power input	16,0	20,0	21,8	25,5	28,6	34,1	37,7	42,0	47,0	53,1	59,5	67,1	75,3	kW
	EER	2,61	2,52	2,51	2,51	2,47	2,49	2,50	2,50	2,47	2,47	2,47	2,53	2,51	W/W
	SEER	3,50	3,56	3,41	3,52	3,60	3,42	3,42	3,43	3,45	3,41	3,48	3,45	3,47	W/W
	Water flow rate	2,01	2,43	2,64	3,08	3,40	4,09	4,54	5,06	5,59	6,31	7,07	8,17	9,08	l/s
	Pressure drops	35	50	49	45	41	42	40	39	41	40	42	43	45	kPa
A7W45	Heating capacity	46,9	56,5	61,7	72,5	80,9	97,0	107	122	133	150	168	192	211	kW
	Power input	14,9	18,2	20,0	23,2	26,4	31,9	34,2	39,2	42,8	49,4	54,3	62,1	68,5	kW
	COP	3,15	3,10	3,09	3,13	3,06	3,04	3,13	3,11	3,11	3,04	3,09	3,09	3,08	W/W
	Water flow rate	2,23	2,68	2,92	3,44	3,83	4,60	5,06	5,78	6,31	7,12	7,98	9,08	9,99	l/s
	Pressure drops	43	61	60	56	52	54	50	51	53	51	54	54	55	kPa
IP	eXtra low noise setting up (AX)	40.2	50.2	60.2	70.2	80.2	90.2	100.2	115.2	130.2	145.2	160.2	180.2	200.2	
A35W7	Cooling capacity	41,0	49,3	53,7	62,8	69,3	83,3	92,5	102	114	129	144	166	185	kW
	Power input	17,1	21,1	23,0	26,8	30,1	35,9	39,8	44,3	49,5	56,0	62,7	70,8	79,4	kW
	EER	2,40	2,34	2,33	2,34	2,30	2,32	2,32	2,30	2,30	2,30	2,30	2,34	2,33	W/W
	SEER	3,52	3,57	3,44	3,55	3,63	3,43	3,43	3,45	3,47	3,44	3,51	3,48	3,51	W/W
	Water flow rate	1,97	2,37	2,58	3,02	3,33	4,00	4,45	4,92	5,49	6,21	6,93	7,98	8,89	l/s
	Pressure drops	33	48	47	43	39	41	38	37	40	39	40	41	43	kPa
A7W45	Heating capacity	45,2	54,5	59,4	70,0	78,0	93,5	104	118	128	145	162	184	203	kW
	Power input	14,2	17,3	19,0	22,2	25,1	30,4	32,7	37,3	40,8	47,1	51,7	59,1	65,1	kW
	COP	3,18	3,15	3,13	3,15	3,11	3,08	3,18	3,16	3,14	3,08	3,13	3,11	3,12	W/W
	Water flow rate	2,15	2,58	2,81	3,32	3,70	4,43	4,92	5,59	6,07	6,88	7,69	8,74	9,60	l/s
	Pressure drops	40	57	55	52	48	50	47	48	49	48	50	50	50	kPa

The values are referred to units without options and accessories.

Data declared according to **EN 14511**:

EER (Energy Efficiency Ratio) = ratio of the total cooling capacity to the effective power input of the unit

COP (Coefficient Of Performance) = ratio of the total heating capacity to the effective power input of the unit

SEER (Seasonal Energy Efficiency Ratio) dichiarato secondo EN 14825

A35W7 = source : air in 35°C d.b. / plant : water in 12°C out 7°C

A7W45 = source : air in 7°C d.b. 6°C w.b. / plant : water in 40°C out 45°C

* Calculated value with option modulating fans regulation

Acoustic performances

Base setting up (AB)	40.2	50.2	60.2	70.2	80.2	90.2	100.2	115.2	130.2	145.2	160.2	180.2	200.2	
Sound power level ^(E)	82	82	83	84	84	85	85	85	86	87	87	88	88	dB(A)
Sound pressure level at 1 meter	64	64	65	66	66	67	67	67	68	69	69	69	69	dB(A)
Sound pressure level at 5 meters	55	55	56	57	57	58	58	58	59	60	60	61	61	dB(A)
Sound pressure level at 10 meters	50	50	51	52	52	53	53	53	54	55	55	56	56	dB(A)
Low noise setting up (AS)	40.2	50.2	60.2	70.2	80.2	90.2	100.2	115.2	130.2	145.2	160.2	180.2	200.2	
Sound power level ^(E)	79	79	80	81	81	82	82	82	83	84	84	85	85	dB(A)
Sound pressure level at 1 meter	61	61	62	63	63	64	64	64	65	66	66	66	66	dB(A)
Sound pressure level at 5 meters	52	52	53	54	54	55	55	55	56	57	57	58	58	dB(A)
Sound pressure level at 10 meters	47	47	48	49	49	50	50	50	51	52	52	53	53	dB(A)
eXtra low noise setting up (AX)	40.2	50.2	60.2	70.2	80.2	90.2	100.2	115.2	130.2	145.2	160.2	180.2	200.2	
Sound power level ^(E)	77	77	78	79	79	80	80	80	81	82	82	83	83	dB(A)
Sound pressure level at 1 meter	59	59	60	61	61	62	62	62	63	64	64	64	64	dB(A)
Sound pressure level at 5 meters	50	50	51	52	52	53	53	53	54	55	55	56	56	dB(A)
Sound pressure level at 10 meters	45	45	46	47	47	48	48	48	49	50	50	51	51	dB(A)

(E): EUROVENT certified data

The acoustic performances are referred to units operating in cooling mode at nominal conditions A35W7.

Unit placed in free field on reflecting surface (directional factor equal to 2).

The sound power level is measured according to ISO 9614 standard.

The sound pressure level is calculated according to ISO 3744 and is referred to a distance of 1/5/10 metres from the external surface of the unit.

Technical data

Unit	40.2	50.2	60.2	70.2	80.2	90.2	100.2	115.2	130.2	145.2	160.2	180.2	200.2	
Power supply	400 - 3+N - 50						400 - 3 - 50						V-ph-Hz	
Compressor type	scroll													-
N° compressors / N° refrigerant circuits	2 / 1													n°
Plant side heat exchanger type	stainless steel brazed plates													-
Source side heat exchanger type	finned coil													-
Fans type	axial													-
N° fans	2	3			2			3	4			n°		
Tank volume	200						400			460				l
Hydraulic fittings	2" VICTAULIC						2" 1/2 VICTAULIC						-	

Electrical data

Standard unit	40.2	50.2	60.2	70.2	80.2	90.2	100.2	115.2	130.2	145.2	160.2	180.2	200.2	
FLA - Full load current at maximum tolerated conditions	40,2	45,7	53,3	58,7	69,6	75,5	90,0	97,9	106	123	136	159	170	A
FLI - Full load power input at maximum tolerated conditions	21,6	24,4	28,4	31,0	36,2	44,0	55,0	60,5	66,0	75,7	83,3	95,4	103	kW
MIC - Maximum instantaneous current of the unit	134	143	149	173	213	264	259	267	267	348	361	355	391	A
MIC SS - Maximum instantaneous current of the unit with soft starter options	89,3	96,3	101	117	143	174	175	183	183	200	246	248	272	A
Unit with high head modulating pump	40.2	50.2	60.2	70.2	80.2	90.2	100.2	115.2	130.2	145.2	160.2	180.2	200.2	
FLA - Full load current at maximum tolerated conditions	46,3	51,8	59,4	64,8	76,0	81,6	96,1	107	115	132	147	169	180	A
FLI - Full load power input at maximum tolerated conditions	25,1	27,9	31,9	34,5	42,1	47,5	58,5	65,1	70,6	80,3	89,6	102	109	kW
MIC - Maximum instantaneous current of the unit	140	150	155	179	219	270	265	276	276	357	372	365	402	A
MIC SS - Maximum instantaneous current of the unit with soft starter options	95,4	102	107	123	150	180	181	192	192	209	257	258	282	A

Operative range

Temperature	Unit type	Cooling		Heating		
		min	max	min	max	
Outdoor air inlet temperature	IR, BR, IP, BP	-10*	52**	-10	40*	(°C)
Water outlet temperature	IR, IP	5	25	30	55	(°C)
Water outlet temperature	BR, BP	-12	5	30	55	(°C)
Water outlet temperature (VD)	IR, BR, IP, BP	30	70	30	70	(°C)
Water outlet temperature (VR)	IR, BR	30	55	-	-	(°C)

* with fans modulating control option (condensation / evaporation control)

** with ATC outdoor high temperature protection function

VD and VR versions

These units allow to recover the heating power, otherwise wasted on air, through an additional heat exchanger. The **Desuperheater Version (VD)** allow the hot water production at temperatures between 30 and 70°C through the partial heat recovery of the condensation heat. **The Total Recovery Version (VR)** allows the cold water production and, at the same time, the hot water production at temperatures between 30 and 55°C through the total recovery of the condensation heat.

Desupeheater Version (VD) - NET NOMINAL performances

IR	Base setting up (AB)	40.2	50.2	60.2	70.2	80.2	90.2	100.2	115.2	130.2	145.2	160.2	180.2	200.2	
A35W7 - W45	Cooling capacity	46,8	55,1	60,3	71	81,1	93,8	105	115	130	148	163	185	206	kW
	Total power input	15,3	18,3	20,3	23,4	27,3	31,8	35,1	38,9	44	50,3	55,8	63	69,9	kW
	EER	3,05	3	2,98	3,03	2,97	2,95	2,99	2,96	2,95	2,94	2,92	2,94	2,95	W/W
	HRE	3,93	3,86	3,84	3,88	3,83	3,8	3,86	3,85	3,83	3,81	3,8	3,82	3,83	W/W
	Water flow rate	2,25	2,66	2,91	3,42	3,91	4,52	5,06	5,54	6,26	7,12	7,84	8,93	9,94	l/s
	Water pressure drop	43	60	59	55	54	52	50	47	52	51	52	52	54	kPa
	Heating recovery capacity	13,5	15,7	17,6	20	23,6	27,1	30,4	34,4	38,4	44	49,3	55,4	61,3	kW
	Water flow rate recovery	0,65	0,75	0,84	0,96	1,13	1,29	1,45	1,64	1,83	2,1	2,36	2,65	2,93	l/s
	Water pressure drop recovery	6	9	11	14	19	15	18	11	14	18	22	18	21	kPa
	IP	Base setting up (AB)	40.2	50.2	60.2	70.2	80.2	90.2	100.2	115.2	130.2	145.2	160.2	180.2	200.2
Cooling capacity		45,3	54,5	59,3	69,3	76,5	92,1	102	113	126	143	159	183	204	kW
Total power input		15,1	18,5	20,1	23,5	26,4	31,5	34,9	38,7	43,4	49,1	54,9	62,1	69,5	kW
EER		3	2,94	2,94	2,95	2,9	2,92	2,93	2,92	2,9	2,91	2,89	2,95	2,94	W/W
HRE		3,86	3,76	3,79	3,78	3,77	3,75	3,77	3,78	3,76	3,77	3,75	3,8	3,77	W/W
Water flow rate		2,18	2,63	2,86	3,34	3,68	4,43	4,92	5,45	6,07	6,88	7,64	8,84	9,84	l/s
Water pressure drop		41	59	57	53	48	50	47	46	49	48	49	51	53	kPa
Heating recovery capacity		13	15,2	17	19,4	22,9	26,2	29,2	33,2	37,1	42,4	47,5	52,4	58,1	kW
Water flow rate recovery		0,62	0,73	0,81	0,93	1,09	1,25	1,4	1,59	1,77	2,03	2,27	2,5	2,78	l/s
Water pressure drop recovery		6	8	10	13	18	14	17	10	13	17	21	16	19	kPa

Total Recovery Version (VR) - NET NOMINAL performances

IR	Base setting up (AB)	40.2	50.2	60.2	70.2	80.2	90.2	100.2	115.2	130.2	145.2	160.2	180.2	200.2	
A35W7 - W45	Cooling capacity	46,8	55,1	60,3	71	81,1	93,8	105	115	130	148	163	185	206	kW
	Total power input	13,9	16,9	18,4	21,4	25,3	27,9	31,1	35	40	44,4	49,9	55,3	62,1	kW
	EER	3,36	3,25	3,28	3,31	3,2	3,36	3,38	3,29	3,25	3,33	3,26	3,35	3,32	W/W
	HRE	7,67	7,46	7,52	7,58	7,35	7,67	7,71	7,52	7,45	7,61	7,47	7,65	7,59	W/W
	Water flow rate	2,25	2,66	2,91	3,42	3,91	4,52	5,06	5,54	6,26	7,12	7,84	8,93	9,94	l/s
	Water pressure drop	43	60	59	55	54	52	50	47	52	51	52	52	54	kPa
	Heating recovery capacity	60	71,2	77,8	91,4	105	120	135	148	168	190	210	238	265	kW
	Water flow rate recovery	2,87	3,4	3,72	4,37	5,02	5,73	6,45	7,07	8,03	9,08	10	11,4	12,7	l/s
	Water pressure drop recovery	35	49	41	45	50	48	52	47	52	51	52	55	55	kPa

Data declared according to EN 14511. The values are referred to units without options and accessories.

EER (Energy Efficiency Ratio) = ratio of the total cooling capacity to the effective power input of the unit

HRE (Heat Recovery Efficiency) = ratio of the total capacity of the system (heating plus cooling capacity) to the effective power input

A35W7 - W45 = source : air in 35°C d.b. / plant : water in 12°C out 7°C / Recovery : water in 40°C out 45°C

CONTROL SYSTEM

The units are equipped with a controller designed to ensure energy saving and unit efficiency. Available functions :

- Adaptive function
- Dynamic defrost
- Sound management
- Climatic control in heating and in cooling mode
- Economy function
- Demand limit
- Integrative heating
- Remote stand by
- Remote cooling-heating



DIMENSIONS - MINIMUM OPERATING AREA - WEIGHT

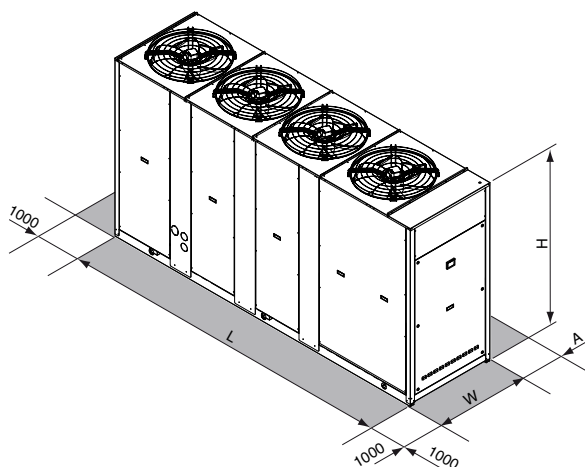

	40.2	50.2	60.2	70.2	80.2	90.2	100.2	115.2	130.2	145.2	160.2	180.2	200.2	
L			2480				3322			3322			4080	mm
W			954				1104			1104			1104	mm
H			1930				1793			2193			2193	mm
A			1600							2000				mm
Operating maximum weight*	1027	1031	1053	1088	1107	1587	1668	1749	1833	1891	1935	2260	2296	kg

* Weight refers to the unit IP with tank and pumping module 2 pumps.

> RGA HE

AIR-WATER CHILLERS AND HEAT PUMPS FOR OUTDOOR INSTALLATION



Efficiency capacity in heating mode - Heat pump low temperature - Medium temperature level

Acoustic setting up	40.2	50.2	60.2	70.2	80.2
AB	A+	A+	A+	A+	A+
AS	A+	A+	A+	A+	A+
AX	A+	A+	A+	A+	A+

NOTA: Declared according to European regulation 811/2013. The values are referred to units without options and accessories.

Available range

Unit type

IR	Chiller
IP	Heat pump (reversible on the refrigerant side)
BR	Chiller Brine
BP	Heat pump Brine (reversible on the refrigerant side)

Version

VB	Base version
VD	Desuperheater version
VR	Total recovery version

Acoustic setting up

AB	Base setting up
AS	Low noise setting up
AX	eXtra low noise setting up

Source temperature level

M	Medium temperature level
A	High temperature level

Unit description

This series of air-water chillers and heat pumps satisfies the cooling and heating requirements of residential plants of medium size.

All the units are suitable for outdoor installation and can be applied to fan coil plants, radiant floor plants and high efficiency radiators plants.

The refrigerant circuit, contained in a compartment protected from the air flow to simplify the maintenance operations, is equipped with scroll compressors mounted on damper supports, brazed plate heat exchanger, thermostatic expansion valve (standard for IR) or electronic expansion valve (standard for IP / option for IR),

reverse cycle valve, dehydrator filter, axial fans with safety protection grilles, finned coil made of copper pipes and aluminium louvered fins with subcooling section. The circuit is protected by a safety gas valve, high and low pressure switches and differential pressure switch on the plate heat exchanger. The plate heat exchanger and all the hydraulic pipes are thermally insulated in order to avoid condensate generation and to reduce thermal losses.

All the units can be equipped with variable speed fans control that allows the units to operate with low outdoor temperatures in cooling and high outdoor temperature in heating and permits to reduce noise emissions in such operating conditions.

The low noise acoustic setting up (AS) is obtained, starting from the base setting up (AB), reducing the rotational speed of the fans and mounting sound jackets on the compressors and the technical compartment is clad with soundproofing material of suitable thickness.

The eXtra low noise acoustic setting up (AX) is obtained, starting from the low noise setting up (AS), further reducing the rotational speed of the fans and using finned coil with bigger surface.

All the units are supplied with a management and control electrical panel containing general switch, phase presence and correct sequence controller, microprocessor controller with display and all the other electrical components with IP54 minimum protection degree.

All the units are accurately built and individually tested in the factory. Only electric and hydraulic connections are required for installation.

Options

Storing and pumping module available in the configurations :

- Storage tank arranged as buffer on the flow or as primary-secondary buffer
- 1 or 2 pumps
- standard or high head pump
- modulating pump

Expansion valve

- thermostatic
- electronic (standard for IP)

Compressor starting

- standard (contactors)
- soft starter

Fans control

- on-off control
- modulating control (condensation / evaporation control)

Compressor power factor correction

Electrical load protection

- fuses
- thermal magnetic circuit breakers

Coil condensate tray

Accessories

- Rubber vibration dampers
- Spring vibration dampers
- Coil protection grilles
- Tank antifreeze electrical heater
- Remote control
- Modbus serial interface on RS485
- Programmer clock
- Phase sequence and voltage controller
- Low temperature kit (standard for IP)
- High and low pressure gauges
- High temperature thermostat
- Outdoor air sensor
- Water flow switch
- Victaulic hydraulic fittings

NET NOMINAL performances - Standard plants - EUROVENT certified data

IR	Base setting up (AB)	40.2	50.2	60.2	70.2	80.2	90.2	100.2	115.2	130.2	145.2	160.2	180.2	
A35W7	Cooling capacity	47,2	55,9	63,1	70,5	83,4	94,9	106	120	133	153	173	197	kW
	Power input	14,9	17,2	19,8	22,1	27,2	31,2	34,6	38,6	42,7	50,0	55,5	64,6	kW
	EER	3,17	3,25	3,19	3,19	3,07	3,04	3,06	3,11	3,11	3,06	3,12	3,05	W/W
	SEER*	4,14	4,15	4,11	4,16	4,10	4,12	4,12	4,13	4,15	4,13	4,10	4,13	W/W
	Water flow rate	2,26	2,69	3,03	3,39	4,00	4,56	5,11	5,78	6,40	7,36	8,31	9,46	l/s
	Pressure drops	24	34	33	41	31	32	34	33	35	35	38	39	kPa
IR	Low noise setting up (AS)	40.2	50.2	60.2	70.2	80.2	90.2	100.2	115.2	130.2	145.2	160.2	180.2	
A35W7	Cooling capacity	45,0	53,3	60,1	67,3	79,5	90,5	101	114	127	146	165	188	kW
	Power input	15,5	17,9	20,6	22,9	27,7	31,9	35,6	39,8	44,3	51,3	57,2	66,3	kW
	EER	2,90	2,98	2,92	2,94	2,87	2,84	2,84	2,86	2,87	2,85	2,88	2,84	W/W
	SEER	3,96	3,99	3,95	4,02	4,04	4,01	3,90	4,00	3,97	3,93	3,98	3,95	W/W
	Water flow rate	2,16	2,56	2,89	3,23	3,82	4,34	4,87	5,49	6,12	7,02	7,93	9,03	l/s
	Pressure drops	22	31	30	37	28	29	31	30	32	32	35	36	kPa
IR	eXtra low noise setting up (AX)	40.2	50.2	60.2	70.2	80.2	90.2	100.2	115.2	130.2	145.2	160.2	180.2	
A35W7	Cooling capacity	44,3	52,4	59,1	66,1	78,2	89,0	100	112	125	143	162	184	kW
	Power input	15,6	18,1	20,8	23,2	27,9	32,3	36,0	40,4	44,9	51,8	57,8	66,9	kW
	EER	2,84	2,90	2,84	2,85	2,80	2,76	2,76	2,77	2,78	2,76	2,80	2,75	W/W
	SEER	4,07	4,09	4,03	4,09	4,07	4,07	3,95	4,04	4,00	3,99	4,03	4,01	W/W
	Water flow rate	2,12	2,51	2,84	3,18	3,75	4,27	4,78	5,40	6,02	6,88	7,79	8,84	l/s
	Pressure drops	21	30	29	36	27	28	30	29	31	31	33	34	kPa
IP	Base setting up (AB)	40.2	50.2	60.2	70.2	80.2	90.2	100.2	115.2	130.2	145.2	160.2	180.2	
A35W7	Cooling capacity	45,3	53,6	60,7	67,8	81,3	92,4	103	115	128	147	166	191	kW
	Power input	14,6	17,1	19,4	21,7	26,7	30,2	33,8	37,8	41,8	48,5	54,3	62,8	kW
	EER	3,10	3,13	3,13	3,12	3,04	3,06	3,05	3,04	3,06	3,03	3,06	3,04	W/W
	SEER	4,03	4,10	4,02	4,01	3,84	3,92	3,93	3,94	4,03	3,94	4,03	3,94	W/W
	Water flow rate	2,17	2,58	2,91	3,26	3,90	4,43	4,97	5,54	6,16	7,07	7,98	9,17	l/s
	Pressure drops	22	31	30	38	29	30	32	30	32	32	35	37	kPa
A7W45	Heating capacity	49,4	58,3	66,0	74,1	88,4	100	113	126	141	161	181	207	kW
	Power input	15,5	18,1	20,8	23,4	27,9	31,6	35,5	39,7	44,3	51,0	57,1	65,6	kW
	COP	3,19	3,22	3,17	3,17	3,17	3,16	3,18	3,17	3,18	3,16	3,17	3,16	W/W
	Water flow rate	2,35	2,77	3,13	3,52	4,20	4,77	5,35	5,97	6,69	7,64	8,60	9,84	l/s
	Pressure drops	26	36	35	44	34	35	37	35	38	38	41	42	kPa
IP	Low noise setting up (AS)	40.2	50.2	60.2	70.2	80.2	90.2	100.2	115.2	130.2	145.2	160.2	180.2	
A35W7	Cooling capacity	43,2	51,1	57,8	64,6	77,5	88,0	98,6	110	122	140	158	182	kW
	Power input	15,1	17,7	20,1	22,6	27,1	31,0	34,8	39,0	43,3	49,8	56,1	64,4	kW
	EER	2,86	2,89	2,88	2,86	2,86	2,84	2,83	2,82	2,82	2,81	2,82	2,83	W/W
	SEER	3,96	4,02	3,96	3,96	3,79	3,88	3,89	3,89	3,97	3,90	3,98	3,89	W/W
	Water flow rate	2,07	2,45	2,78	3,11	3,72	4,22	4,73	5,26	5,88	6,74	7,60	8,74	l/s
	Pressure drops	20	28	28	35	27	27	29	27	30	29	32	33	kPa
A7W45	Heating capacity	48,1	56,8	64,2	72,2	86,0	97,7	110	123	137	157	176	202	kW
	Power input	14,9	17,5	20,0	22,7	26,4	30,1	34,0	38,2	42,8	48,8	54,8	62,7	kW
	COP	3,23	3,25	3,21	3,18	3,26	3,25	3,24	3,22	3,20	3,22	3,21	3,22	W/W
	Water flow rate	2,29	2,70	3,05	3,43	4,09	4,64	5,21	5,83	6,50	7,45	8,36	9,60	l/s
	Pressure drops	25	34	33	42	32	33	35	34	36	36	38	40	kPa
IP	eXtra low noise setting up (AX)	40.2	50.2	60.2	70.2	80.2	90.2	100.2	115.2	130.2	145.2	160.2	180.2	
A35W7	Cooling capacity	42,5	50,3	56,9	63,6	76,2	86,5	97,0	109	120	138	155	179	kW
	Power input	15,3	18,0	20,3	22,8	27,4	31,4	35,2	39,6	44,0	50,2	56,7	65,0	kW
	EER	2,78	2,79	2,80	2,79	2,78	2,75	2,76	2,75	2,73	2,75	2,73	2,75	W/W
	SEER	4,00	4,05	4,00	4,00	3,81	3,90	3,90	3,92	4,01	3,92	4,01	3,91	W/W
	Water flow rate	2,04	2,41	2,73	3,05	3,66	4,15	4,65	5,21	5,78	6,64	7,45	8,60	l/s
	Pressure drops	20	27	27	33	26	27	28	27	29	28	31	32	kPa
A7W45	Heating capacity	47,6	56,1	63,4	71,3	85,0	96,5	109	121	136	155	174	199	kW
	Power input	14,7	17,2	19,6	22,2	25,9	29,5	33,3	37,4	42,0	47,7	53,6	61,3	kW
	COP	3,24	3,26	3,23	3,21	3,28	3,27	3,27	3,24	3,24	3,25	3,25	3,25	W/W
	Water flow rate	2,26	2,67	3,01	3,38	4,04	4,59	5,16	5,73	6,45	7,36	8,27	9,46	l/s
	Pressure drops	24	33	33	41	32	32	35	32	36	35	38	39	kPa

The values are referred to units without options and accessories.

Data declared according to **EN 14511**:

EER (Energy Efficiency Ratio) = ratio of the total cooling capacity to the effective power input of the unit

COP (Coefficient Of Performance) = ratio of the total heating capacity to the effective power input of the unit

SEER (Seasonal Energy Efficiency Ratio) dichiarato secondo EN 14825

A35W7 = source : air in 35°C d.b. / plant : water in 12°C out 7°C

A7W45 = source : air in 7°C d.b. 6°C w.b. / plant : water in 40°C out 45°C

* Calculated value with option modulating fans regulation

Acoustic performances

Base setting up (AB)	40.2	50.2	60.2	70.2	80.2	90.2	100.2	115.2	130.2	145.2	160.2	180.2	
Sound power level ^(E)	82	82	83	84	85	85	85	85	86	87	87	88	dB(A)
Sound pressure level at 1 meter	64	64	65	66	67	67	67	67	68	69	69	69	dB(A)
Sound pressure level at 5 meters	55	55	56	57	58	58	58	58	59	60	60	61	dB(A)
Sound pressure level at 10 meters	50	50	51	52	53	53	53	53	54	55	55	56	dB(A)
Low noise setting up (AS)	40.2	50.2	60.2	70.2	80.2	90.2	100.2	115.2	130.2	145.2	160.2	180.2	
Sound power level ^(E)	79	79	80	81	82	82	82	82	83	84	84	85	dB(A)
Sound pressure level at 1 meter	61	61	62	63	64	64	64	64	65	66	66	66	dB(A)
Sound pressure level at 5 meters	52	52	53	54	55	55	55	55	56	57	57	58	dB(A)
Sound pressure level at 10 meters	47	47	48	49	50	50	50	50	51	52	52	53	dB(A)
eXtra low noise setting up (AX)	40.2	50.2	60.2	70.2	80.2	90.2	100.2	115.2	130.2	145.2	160.2	180.2	
Sound power level ^(E)	77	77	78	79	80	80	80	80	81	82	82	83	dB(A)
Sound pressure level at 1 meter	59	59	60	61	62	62	62	62	63	64	64	64	dB(A)
Sound pressure level at 5 meters	50	50	51	52	53	53	53	53	54	55	55	56	dB(A)
Sound pressure level at 10 meters	45	45	46	47	48	48	48	48	49	50	50	51	dB(A)

(E): EUROVENT certified data

The acoustic performances are referred to units operating in cooling mode at nominal conditions A35W7.

Unit placed in free field on reflecting surface (directional factor equal to 2).

The sound power level is measured according to ISO 9614 standard.

The sound pressure level is calculated according to ISO 3744 and is referred to a distance of 1/5/10 metres from the external surface of the unit.

Technical data

Unit	40.2	50.2	60.2	70.2	80.2	90.2	100.2	115.2	130.2	145.2	160.2	180.2	
Power supply	400 - 3+N - 50				400 - 3 - 50								V-ph-Hz
Compressor type	scroll												-
N° compressors / N° refrigerant circuits	2 / 1												n°
Plant side heat exchanger type	stainless steel brazed plates												-
Source side heat exchanger type	finned coil												-
Fans type	axial												-
N° fans	2	3		2				3		4			n°
Tank volume	200				400				460				l
Hydraulic fittings	2" VICTAULIC				2" 1/2 VICTAULIC								-

Electrical data

Standard unit	40.2	50.2	60.2	70.2	80.2	90.2	100.2	115.2	130.2	145.2	160.2	180.2	
FLA - Full load current at maximum tolerated conditions	40,2	45,7	53,3	58,7	69,6	75,5	90,0	97,9	106	123	136	159	A
FLI - Full load power input at maximum tolerated conditions	21,6	24,4	28,4	31,0	36,2	44,0	55,0	60,5	66,0	75,7	83,3	95,4	kW
MIC - Maximum instantaneous current of the unit	134	143	149	173	213	264	259	267	267	348	361	355	A
MIC SS - Maximum instantaneous current of the unit with soft starter options	89,3	96,3	101	117	143	174	175	183	183	200	246	248	A
Unit with high head modulating pump	40.2	50.2	60.2	70.2	80.2	90.2	100.2	115.2	130.2	145.2	160.2	180.2	
FLA - Full load current at maximum tolerated conditions	46,3	51,8	59,4	64,8	76,0	81,6	96,1	107	115	132	147	169	A
FLI - Full load power input at maximum tolerated conditions	25,1	27,9	31,9	34,5	42,1	47,5	58,5	65,1	70,6	80,3	89,6	102	kW
MIC - Maximum instantaneous current of the unit	140	150	155	179	219	270	265	276	276	357	372	365	A
MIC SS - Maximum instantaneous current of the unit with soft starter options	95,4	102	107	123	150	180	181	192	192	209	257	258	A

Operative range

Temperature	Unit type	Cooling		Heating		
		min	max	min	max	
Outdoor air inlet temperature	IR, BR, IP, BP	-10*	52**	-15	40*	(°C)
Water outlet temperature	IR, IP	5	25	30	55	(°C)
Water outlet temperature	BR, BP	-12	5	30	55	(°C)
Water outlet temperature (VD)	IR, BR, IP, BP	30	70	30	70	(°C)
Water outlet temperature (VR)	IR, BR	30	55	-	-	(°C)

* with fans modulating control option (condensation / evaporation control)

** with ATC outdoor high temperature protection function

VD and VR versions

These units allow to recover the heating power, otherwise wasted on air, through an additional heat exchanger.

The **Desuperheater Version (VD)** allow the hot water production at temperatures between 30 and 70°C through the partial heat recovery of the condensation heat.

The **Total Recovery Version (VR)** allows the cold water production and, at the same time, the hot water production at temperatures between 30 and 55°C through the total recovery of the condensation heat.

Desupeheater Version (VD) - NET NOMINAL performances

IR	Base setting up (AB)	40.2	50.2	60.2	70.2	80.2	90.2	100.2	115.2	130.2	145.2	160.2	180.2	
A35W7 - W45	Cooling capacity	49,1	58,1	65,5	73,3	86,7	98,6	110	125	138	159	180	205	kW
	Total power input	14,5	16,7	19,4	21,5	26,6	30,5	33,8	37,7	41,6	48,8	54,1	63,1	kW
	EER	3,38	3,47	3,38	3,41	3,26	3,24	3,27	3,32	3,32	3,26	3,32	3,24	W/W
	HRE	4,36	4,48	4,36	4,4	4,21	4,18	4,22	4,28	4,29	4,21	4,29	4,19	W/W
	Water flow rate	2,36	2,79	3,15	3,53	4,17	4,74	5,3	6,02	6,64	7,64	8,65	9,84	l/s
	Water pressure drop	26	37	36	44	34	35	37	36	38	38	41	42	kPa
	Heating recovery capacity	14,2	16,9	19	21,3	25,1	28,6	32,1	36,2	40,3	46,3	52,3	59,4	kW
	Water flow rate recovery	0,68	0,81	0,91	1,02	1,2	1,37	1,53	1,73	1,93	2,21	2,5	2,84	l/s
	Water pressure drop recovery	7	10	13	16	21	16	20	12	15	20	25	20	kPa
	IP	Base setting up (AB)	40.2	50.2	60.2	70.2	80.2	90.2	100.2	115.2	130.2	145.2	160.2	180.2
A35W7 - W45	Cooling capacity	47,1	55,8	63,1	70,4	84,6	96	107	120	133	153	173	199	kW
	Total power input	14,2	16,6	18,9	21,2	26	29,5	33	36,8	40,7	47,3	53,1	61,4	kW
	EER	3,32	3,36	3,33	3,33	3,25	3,25	3,25	3,27	3,27	3,24	3,26	3,24	W/W
	HRE	4,28	4,34	4,3	4,3	4,19	4,2	4,2	4,21	4,22	4,18	4,2	4,17	W/W
	Water flow rate	2,26	2,68	3,03	3,39	4,06	4,61	5,16	5,78	6,4	7,36	8,31	9,56	l/s
	Water pressure drop	24	34	33	41	32	33	35	33	35	35	38	40	kPa
	Heating recovery capacity	13,6	16,2	18,3	20,5	24,5	27,9	31,1	34,7	38,6	44,4	50,1	57,5	kW
	Water flow rate recovery	0,65	0,77	0,87	0,98	1,17	1,33	1,49	1,66	1,84	2,12	2,39	2,75	l/s
	Water pressure drop recovery	7	9	12	14	20	16	19	11	14	18	23	19	kPa

Total Recovery Version (VR) - NET NOMINAL performances

IR	Base setting up (AB)	40.2	50.2	60.2	70.2	80.2	90.2	100.2	115.2	130.2	145.2	160.2	180.2	
A35W7 - W45	Cooling capacity	49,1	58,1	65,5	73,3	86,7	98,6	110	125	138	159	180	205	kW
	Total power input	13,2	15,4	17,4	19,5	22,8	26,6	29,9	33,7	37,7	43	48,2	55,4	kW
	EER	3,72	3,76	3,77	3,75	3,81	3,72	3,7	3,71	3,66	3,7	3,73	3,7	W/W
	HRE	8,39	8,47	8,49	8,46	8,55	8,39	8,35	8,37	8,27	8,36	8,42	8,34	W/W
	Water flow rate	2,36	2,79	3,15	3,53	4,17	4,74	5,3	6,02	6,64	7,64	8,65	9,84	l/s
	Water pressure drop	26	37	36	44	34	35	37	36	38	38	41	42	kPa
	Heating recovery capacity	61,7	72,7	82,1	91,9	108	124	139	157	174	200	226	257	kW
	Water flow rate recovery	2,95	3,47	3,92	4,39	5,16	5,92	6,64	7,5	8,31	9,56	10,8	12,3	l/s
	Water pressure drop recovery	34	47	42	41	48	47	52	49	51	50	54	53	kPa

Data declared according to **EN 14511**. The values are referred to units without options and accessories.

EER (Energy Efficiency Ratio) = ratio of the total cooling capacity to the effective power input of the unit

HRE (Heat Recovery Efficiency) = ratio of the total capacity of the system (heating plus cooling capacity) to the effective power input

A35W7 - W45 = source : air in 35°C d.b. / plant : water in 12°C out 7°C / Recovery : water in 40°C out 45°C

CONTROL SYSTEM

The units are equipped with a controller designed to ensure energy saving and unit efficiency. Available functions :

- Adaptive function
- Dynamic defrost
- Sound management
- Climatic control in heating and in cooling mode
- Economy function
- Demand limit
- Integrative heating
- Remote stand by
- Remote cooling-heating



DIMENSIONS - MINIMUM OPERATING AREA - WEIGHT

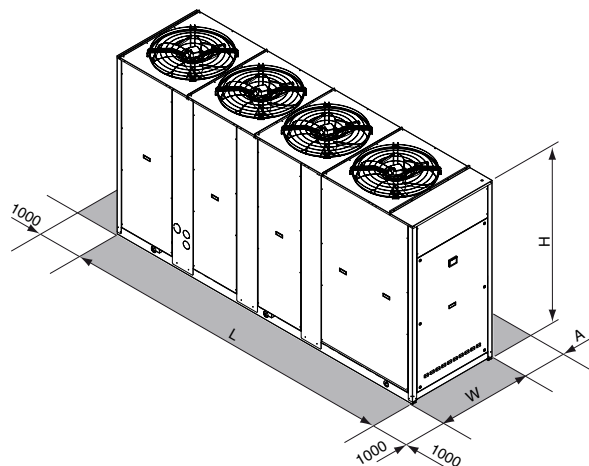

	40.2	50.2	60.2	70.2	80.2	90.2	100.2	115.2	130.2	145.2	160.2	180.2	
L	2480			3322			3322			4080			mm
W	954			1104			1104			1104			mm
H	1930			1793			2193			2193			mm
A	1600			2000			2000			2000			mm
Operating maximum weight*	1068	1072	1095	1132	1569	1650	1735	1877	1906	1967	2292	2350	kg

* Weight refers to the unit IP with tank and pumping module 2 pumps.

> RLA

AIR-WATER CHILLERS AND HEAT PUMPS FOR OUTDOOR INSTALLATION



Available range

Unit type

IR	Chiller
IP	Heat pump (reversible on the refrigerant side)
BR	Chiller Brine
BP	Heat pump Brine (reversible on the refrigerant side)

Version

VB	Base version
VD	Desuperheater version
VR	Total recovery version

Acoustic setting up

AB	Base setting up
AS	Low noise setting up
AX	eXtra low noise setting up

Source temperature level

M	Medium temperature level
A	High temperature level

Unit description

This series of air-water chillers and heat pumps satisfies the cooling and heating requirements of residential plants of medium-large size.

All the units are suitable for outdoor installation and can be applied to fan coil plants, radiant floor plants and high efficiency radiators plants.

The refrigerant circuit, contained in a compartment protected from the air flow to simplify the maintenance operations, is equipped with scroll compressors mounted on damper supports, brazed plate heat exchanger, electronic expansion valve, reverse cycle valve, dehydrator filter, axial fans with safety protection grilles, finned coil made of copper pipes

and aluminium louvered fins with sub-cooling section. The circuit is protected by a safety gas valve, high and low pressure switches and differential pressure switch on the plate heat exchanger. The plate heat exchanger and all the hydraulic pipes are thermally insulated in order to avoid condensate generation and to reduce thermal losses.

All the units can be equipped with variable speed fans control that allows the units to operate with low outdoor temperatures in cooling and high outdoor temperature in heating and permits to reduce noise emissions in such operating conditions.

The low noise acoustic setting up (AS) is obtained, starting from the base setting up (AB), reducing the rotational speed of the fans and mounting sound jackets on the compressors and the technical compartment is clad with soundproofing material of suitable thickness.

The eXtra low noise acoustic setting up (AX) is obtained, starting from the low noise setting up (AS), further reducing the rotational speed of the fans and using finned coil with bigger surface.

All the units are supplied with a management and control electrical panel containing general switch, phase presence and correct sequence controller, microprocessor controller with display and all the other electrical components with IP54 minimum protection degree.

All the units are accurately built and individually tested in the factory. Only electric and hydraulic connections are required for installation.

Options

Storing and pumping module available in the configurations :

- storage tank arranged as buffer on the flow or as primary-secondary buffer
- 1 or 2 pumps
- standard or high head pump

Refrigerant circuit pressures visualization

- high and low pressure gauges
- high and low pressure transducers

High temperature thermostat

Compressor starting

- standard (contactors)
- soft starter

Fans control

- on-off control
- modulating control (condensation / evaporation control)

Compressor power factor correction

Electrical load protection

- fuses
- thermal magnetic circuit breakers

Coil condensate tray

Accessories

Rubber vibration dampers

Spring vibration dampers

Coil protection grilles

Tank antifreeze electrical heater

Remote control

Modbus serial interface on RS485

Programmer clock

Phase sequence and voltage controller

Water flow switch

Victaulic hydraulic fittings

NET NOMINAL performances - Standard plants - EUROVENT certified data

IR	Base setting up (AB)	160.4	180.4	200.4	230.4	260.4	290.4	330.4	375.4	420.4		
A35W7	Cooling capacity	161	178	199	228	255	289	323	368	409	kW	
	Power input	56,2	62,7	70,9	80,4	90,7	103	115	130	146	kW	
	EER	2,86	2,84	2,81	2,84	2,81	2,81	2,81	2,81	2,83	2,80	W/W
	SEER*	3,88	3,92	3,89	3,92	9,83	3,88	3,91	3,91	4,10	4,10	W/W
	Water flow rate	7,74	8,55	9,60	11,0	12,3	14,0	15,6	17,7	19,7	l/s	
	Pressure drops	51	51	58	57	60	64	54	58	58	kPa	
IR	Low noise setting up (AS)	160.4	180.4	200.4	230.4	260.4	290.4	330.4	375.4	420.4		
A35W7	Cooling capacity	155	171	191	219	245	277	311	353	393	kW	
	Power input	59,2	66,1	75,0	85,2	95,5	109	121	137	154	kW	
	EER	2,62	2,59	2,55	2,57	2,57	2,54	2,57	2,58	2,55	W/W	
	SEER*	3,83	3,85	3,82	3,85	3,81	3,83	3,82	3,82	3,89	W/W	
	Water flow rate	7,45	8,22	9,22	10,6	11,8	13,4	15,0	17,0	18,9	l/s	
	Pressure drops	47	47	53	53	56	58	50	53	54	kPa	
IR	eXtra low noise setting up (AX)	160.4	180.4	200.4	230.4	260.4	290.4	330.4	375.4	420.4		
A35W7	Cooling capacity	151	167	187	214	240	272	304	346	385	kW	
	Power input	59,8	66,9	76,0	86,4	96,6	111	123	138	157	kW	
	EER	2,53	2,50	2,46	2,48	2,48	2,45	2,47	2,51	2,45	W/W	
	SEER*	3,84	3,87	3,85	3,87	3,82	3,84	3,85	3,87	3,94	W/W	
	Water flow rate	7,26	8,03	9,03	10,3	11,6	13,1	14,6	16,7	18,5	l/s	
	Pressure drops	45	45	51	50	54	56	47	51	51	kPa	
IP	Base setting up (AB)	160.4	180.4	200.4	230.4	260.4	290.4	330.4	375.4	420.4		
A35W7	Cooling capacity	154	171	192	215	244	275	310	357	397	kW	
	Power input	55,4	61,8	69,6	78,5	89,9	102	113	129	144	kW	
	EER	2,78	2,77	2,76	2,74	2,71	2,70	2,74	2,77	2,76	W/W	
	SEER*	3,62	3,66	3,66	3,73	3,64	3,69	3,79	3,78	3,79	W/W	
	Water flow rate	7,41	8,22	9,27	10,4	11,8	13,3	14,9	17,2	19,2	l/s	
	Pressure drops	47	47	54	51	56	57	49	54	55	kPa	
A7W45	Heating capacity	169	191	215	240	273	308	345	395	439	kW	
	Power input	56,8	64,0	72,3	81,2	92,7	104	116	132	147	kW	
	COP	2,98	2,98	2,97	2,96	2,94	2,96	2,97	2,99	2,99	W/W	
	Water flow rate	8,03	9,03	10,2	11,4	12,9	14,6	16,3	18,7	20,8	l/s	
Pressure drops	55	57	65	62	66	69	59	64	65	kPa		
IP	Low noise setting up (AS)	160.4	180.4	200.4	230.4	260.4	290.4	330.4	375.4	420.4		
A35W7	Cooling capacity	148	164	185	206	234	265	298	343	382	kW	
	Power input	58,3	65,2	73,6	86,4	94,7	107	123	136	152	kW	
	EER	2,54	2,52	2,51	2,38	2,47	2,48	2,42	2,52	2,51	W/W	
	SEER*	3,58	3,62	3,60	3,68	3,59	3,63	3,71	3,71	3,73	W/W	
	Water flow rate	7,12	7,88	8,89	9,94	11,3	12,8	14,3	16,5	18,4	l/s	
	Pressure drops	43	44	49	47	51	53	45	50	51	kPa	
A7W45	Heating capacity	162	183	206	230	262	296	331	379	422	kW	
	Power input	53,5	60,3	68,2	76,6	87,3	99	110	125	140	kW	
	COP	3,03	3,03	3,02	3,00	3,00	2,99	3,01	3,03	3,01	W/W	
	Water flow rate	7,69	8,65	9,75	10,9	12,4	14,0	15,7	17,9	20,0	l/s	
Pressure drops	50	52	59	56	61	64	54	59	60	kPa		
IP	eXtra low noise setting up (AX)	160.4	180.4	200.4	230.4	260.4	290.4	330.4	375.4	420.4		
A35W7	Cooling capacity	145	161	181	203	229	259	291	335	374	kW	
	Power input	59,0	66,1	74,6	84,4	95,8	109	122	137	153	kW	
	EER	2,46	2,44	2,43	2,41	2,39	2,38	2,39	2,45	2,44	W/W	
	SEER*	3,60	3,64	3,64	3,71	3,62	3,66	3,76	3,76	3,76	W/W	
	Water flow rate	6,98	7,74	8,70	9,75	11,0	12,5	14,0	16,1	18,0	l/s	
	Pressure drops	42	42	47	45	48	51	43	48	49	kPa	
A7W45	Heating capacity	161	181	204	228	259	293	328	374	417	kW	
	Power input	51,8	58,5	66,2	74,5	84,6	95,6	106	121	135	kW	
	COP	3,11	3,09	3,08	3,06	3,06	3,06	3,09	3,09	3,09	W/W	
	Water flow rate	7,64	8,60	9,65	10,8	12,3	13,9	15,5	17,7	19,7	l/s	
Pressure drops	50	52	58	55	60	63	53	58	58	kPa		

The values are referred to units without options and accessories.

Data declared according to EN 14511:

EER (Energy Efficiency Ratio) = ratio of the total cooling capacity to the effective power input of the unit

COP (Coefficient Of Performance) = ratio of the total heating capacity to the effective power input of the unit

SEER (Seasonal Energy Efficiency Ratio) dichiarato secondo EN 14825

A35W7 = source : air in 35°C d.b. / plant : water in 12°C out 7°C

A7W45 = source : air in 7°C d.b. 6°C w.b. / plant : water in 40°C out 45°C

* Calculated value with option modulating fans regulation

Acoustic performances

Base setting up (AB)	160.4	180.4	200.4	230.4	260.4	290.4	330.4	375.4	420.4	
Sound power level ^(E)	91	92	92	92	93	94	94	95	95	dB(A)
Sound pressure level at 1 meter	72	73	73	73	74	75	74	75	75	dB(A)
Sound pressure level at 5 meters	64	65	65	65	66	67	67	68	68	dB(A)
Sound pressure level at 10 meters	59	60	60	60	61	62	62	63	63	dB(A)
Low noise setting up (AS)	160.4	180.4	200.4	230.4	260.4	290.4	330.4	375.4	420.4	
Sound power level ^(E)	85	86	86	86	87	88	88	89	89	dB(A)
Sound pressure level at 1 meter	66	67	67	67	68	69	68	69	69	dB(A)
Sound pressure level at 5 meters	58	59	59	59	60	61	61	62	62	dB(A)
Sound pressure level at 10 meters	53	54	54	54	55	56	56	57	57	dB(A)
eXtra low noise setting up (AX)	160.4	180.4	200.4	230.4	260.4	290.4	330.4	375.4	420.4	
Sound power level ^(E)	82	83	83	83	84	85	85	86	86	dB(A)
Sound pressure level at 1 meter	63	64	64	64	65	66	65	66	66	dB(A)
Sound pressure level at 5 meters	55	56	56	56	57	58	58	59	59	dB(A)
Livello di pressione sonora a 10 metri	50	51	51	51	52	53	53	54	54	dB(A)

(E): EUROVENT certified data

The acoustic performances are referred to units operating in cooling mode at nominal conditions A35W7.

Unit placed in free field on reflecting surface (directional factor equal to 2).

The sound power level is measured according to ISO 9614 standard.

The sound pressure level is calculated according to ISO 3744 and is referred to a distance of 1/5/10 metres from the external surface of the unit.

Technical data

Unit	160.4	180.4	200.4	230.4	260.4	290.4	330.4	375.4	420.4	
Power supply	400 - 3 - 50									V-ph-Hz
Compressor type	scroll									-
N° compressors / N° refrigerant circuits	4 / 2									n°
Plant side heat exchanger type	stainless steel brazed plates									-
Source side heat exchanger type	finned coil									-
Fans type	axial									-
N° fans	4			6			8			n°
Tank volume	325						710			l
Hydraulic fittings	3" VICTAULIC						4" VICTAULIC			-

Electrical data

Standard unit	160.4	180.4	200.4	230.4	260.4	290.4	330.4	375.4	420.4	
FLA - Full load current at maximum tolerated conditions	140	151	177	193	217	243	269	314	335	A
FLI - Full load power input at maximum tolerated conditions	76	87	107	118	133	148	163	186	200	kW
MIC - Maximum instantaneous current of the unit	283	340	347	355	379	469	495	510	558	A
MIC SS - Maximum instantaneous current of the unit with soft starter options	213	250	263	271	295	354	380	404	438	A
Unit with high head modulating pump	160.4	180.4	200.4	230.4	260.4	290.4	330.4	375.4	420.4	
FLA - Full load current at maximum tolerated conditions	149	160	187	203	227	256	282	327	357	A
FLI - Full load power input at maximum tolerated conditions	81	91	113	124	139	156	171	194	212	kW
MIC - Maximum instantaneous current of the unit	292	348	357	365	389	482	508	524	580	A
MIC SS - Maximum instantaneous current of the unit with soft starter options	222	258	273	281	305	368	394	417	460	A

Operative range

Temperature	Unit type	Cooling		Heating		
		min	max	min	max	
Outdoor air inlet temperature	IR, BR, IP, BP	-10*	52**	-10	40*	(°C)
Water outlet temperature	IR, IP	5	25	30	55	(°C)
Water outlet temperature	BR, BP	-12	5	30	55	(°C)
Water outlet temperature (VD)	IR, BR, IP, BP	30	70	30	70	(°C)
Water outlet temperature (VR)	IR, BR	30	55	-	-	(°C)

* with fans modulating control option (condensation / evaporation control)

** with ATC outdoor high temperature protection function

VD and VR versions

These units allow to recover the heating power, otherwise wasted on air, through an additional heat exchanger.

The **Desuperheater Version (VD)** allow the hot water production at temperatures between 30 and 70°C through the partial heat recovery of the condensation heat.

The **Total Recovery Version (VR)** allows the cold water production and, at the same time, the hot water production at temperatures between 30 and 55°C through the total recovery of the condensation heat.

Desupeheater Version (VD) - NET NOMINAL performances

IR	Base setting up (AB)	160.4	180.4	200.4	230.4	260.4	290.4	330.4	375.4	420.4	
A35W7 - W45	Cooling capacity	167	185	207	237	264	300	336	382	425	kW
	Total power input	55,0	61,2	69,3	78,5	88,7	101	112	127	143	kW
	EER	3,04	3,01	2,99	3,02	2,98	2,97	3,00	3,01	2,98	W/W
	HRE	3,90	3,89	3,87	3,91	3,85	3,85	3,90	3,88	3,86	W/W
	Water flow rate	8,05	8,89	10,0	11,4	12,8	14,5	16,2	18,4	20,5	l/s
	Water pressure drop	55	55	63	62	65	68	58	62	63	kPa
	Heating recovery capacity	47,2	53,4	61,2	70,3	76,6	88,7	99,9	110,8	126,6	kW
	Water flow rate recovery	2,25	2,55	2,93	3,36	3,66	4,24	4,77	5,29	6,05	l/s
	Water pressure drop recovery	5	7	8	10	13	16	16	21	25	kPa

IP	Base setting up (AB)	160.4	180.4	200.4	230.4	260.4	290.4	330.4	375.4	420.4	
A35W7 - W45	Cooling capacity	160	177	200	224	253	286	322	371	413	kW
	Total power input	54,1	60,4	67,9	76,6	87,8	99	111	126	140	kW
	EER	2,96	2,94	2,94	2,92	2,89	2,88	2,91	2,95	2,96	W/W
	HRE	3,82	3,81	3,83	3,82	3,75	3,76	3,81	3,83	3,85	W/W
	Water flow rate	7,70	8,55	9,64	10,8	12,2	13,8	15,5	17,9	19,9	l/s
	Water pressure drop	51	51	58	55	59	62	53	59	59	kPa
	Heating recovery capacity	46,5	52,7	60,1	68,8	76,1	87,5	98,9	110	124	kW
	Water flow rate recovery	2,22	2,52	2,87	3,29	3,64	4,18	4,73	5,25	5,91	l/s
	Water pressure drop recovery	5	6	8	10	13	16	16	20	24	kPa

Total Recovery Version (VR) - NET NOMINAL performances

IR	Base setting up (AB)	160.4	180.4	200.4	230.4	260.4	290.4	330.4	375.4	420.4	
A35W7 - W45	Cooling capacity	169	186	209	239	267	303	339	386	429	kW
	Total power input	47,3	53,5	61,6	70,7	77,2	89,5	100	111	127	kW
	EER	3,56	3,48	3,39	3,38	3,46	3,39	3,38	3,46	3,37	W/W
	HRE	8,08	7,91	7,75	7,71	7,87	7,72	7,71	7,87	7,69	W/W
	Water flow rate	8,13	8,98	10,1	11,5	12,9	14,6	16,4	18,6	20,7	l/s
	Water pressure drop	56	57	64	63	66	69	59	64	64	kPa
	Heating recovery capacity	214	237	268	306	340	388	434	492	550	kW
	Water flow rate recovery	10,2	11,3	12,8	14,6	16,2	18,5	20,7	23,5	26,3	l/s
	Water pressure drop recovery	45	43	45	45	47	49	49	51	51	kPa

Data declared according to EN 14511. The values are referred to units without options and accessories.

EER (Energy Efficiency Ratio) = ratio of the total cooling capacity to the effective power input of the unit

HRE (Heat Recovery Efficiency) = ratio of the total capacity of the system (heating plus cooling capacity) to the effective power input

A35W7 - W45 = source : air in 35°C d.b. / plant : water in 12°C out 7°C / Recovery : water in 40°C out 45°C

CONTROL SYSTEM

The units are equipped with a controller designed to ensure energy saving and unit efficiency. Available functions :

- ATC outdoor high temperature protection function
- Dynamic defrost
- Sound management
- Climatic control in heating and in cooling mode
- Double set point function
- Demand limit
- Integrative heating
- Remote stand by
- Remote cooling-heating



DIMENSIONS - MINIMUM OPERATING AREA - WEIGHT

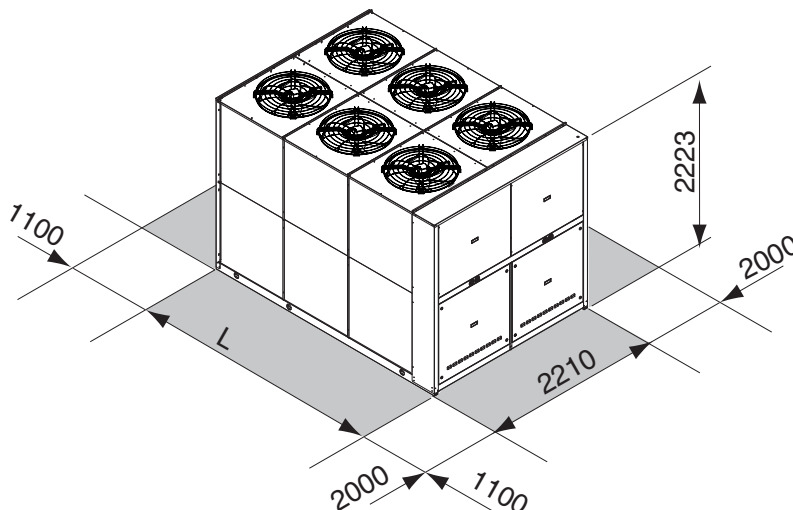

	160.4	180.4	200.4	230.4	260.4	290.4	330.4	375.4	420.4	
L	3164	3164	3164	3164	3164	3164	4097	4097	4097	mm
Operating maximum weight*	2441	2633	2829	3005	3069	3096	3790	3907	3980	kg

* Weight refers to the unit IP with tank and pumping module 2 pumps.

> RLA HE

AIR-WATER CHILLERS AND HEAT PUMPS FOR OUTDOOR INSTALLATION



Available range

Unit type

IR	Chiller
IP	Heat pump (reversible on the refrigerant side)
BR	Chiller Brine
BP	Heat pump Brine (reversible on the refrigerant side)

Version

VB	Base version
VD	Desuperheater version
VR	Total recovery version

Acoustic setting up

AB	Base setting up
AS	Low noise setting up
AX	eXtra low noise setting up

Source temperature level

M	Medium temperature level
A	High temperature level

Unit description

This series of air-water chillers and heat pumps satisfies the cooling and heating requirements of residential plants of medium-large size.

All the units are suitable for outdoor installation and can be applied to fan coil plants, radiant floor plants and high efficiency radiators plants.

The refrigerant circuit, contained in a compartment protected from the air flow to simplify the maintenance operations, is equipped with scroll compressors mounted on damper supports, brazed plate heat exchanger, electronic expansion valve, reverse cycle valve, dehydrator filter, axial fans with safety protection grilles, finned coil made of copper pipes

and aluminium louvered fins with sub-cooling section. The circuit is protected by a safety gas valve, high and low pressure switches and differential pressure switch on the plate heat exchanger. The plate heat exchanger and all the hydraulic pipes are thermally insulated in order to avoid condensate generation and to reduce thermal losses.

All the units can be equipped with variable speed fans control that allows the units to operate with low outdoor temperatures in cooling and high outdoor temperature in heating and permits to reduce noise emissions in such operating conditions.

The low noise acoustic setting up (AS) is obtained, starting from the base setting up (AB), reducing the rotational speed of the fans and mounting sound jackets on the compressors and the technical compartment is clad with soundproofing material of suitable thickness.

The eXtra low noise acoustic setting up (AX) is obtained, starting from the low noise setting up (AS), further reducing the rotational speed of the fans and using finned coil with bigger surface.

All the units are supplied with a management and control electrical panel containing general switch, phase presence and correct sequence controller, microprocessor controller with display and all the other electrical components with IP54 minimum protection degree.

All the units are accurately built and individually tested in the factory. Only electric and hydraulic connections are required for installation.

Options

Storing and pumping module available in the configurations :

- storage tank arranged as buffer on the flow or as primary-secondary buffer
- 1 or 2 pumps
- standard or high head pump

Refrigerant circuit pressures visualization

- high and low pressure gauges
- high and low pressure transducers

High temperature thermostat

Compressor starting

- standard (contactors)
- soft starter

Fans control

- on-off control
- modulating control (condensation / evaporation control)

Compressor power factor correction

Electrical load protection

- fuses
- thermal magnetic circuit breakers

Coil condensate tray

Accessories

Rubber vibration dampers

Spring vibration dampers

Coil protection grilles

Tank antifreeze electrical heater

Remote control

Modbus serial interface on RS485

Programmer clock

Phase sequence and voltage controller

Water flow switch

Victaulic hydraulic fittings

NET NOMINAL performances - Standard plants - EUROVENT certified data

IR	Base setting up (AB)	160.4	180.4	200.4	230.4	260.4	290.4	330.4	375.4	
A35W7	Cooling capacity	172	191	212	237	267	304	340	387	kW
	Power input	52,7	58,0	65,4	74,1	83,6	95	106	122	kW
	EER	3,26	3,29	3,24	3,20	3,19	3,20	3,21	3,17	W/W
	SEER*	4,12	4,16	4,23	4,31	4,16	4,19	4,25	4,24	W/W
	Water flow rate	8,22	9,13	10,13	11,3	12,8	14,5	16,2	18,5	l/s
	Pressure drops	39	36	38	39	40	36	36	33	kPa
IR	Low noise setting up (AS)	160.4	180.4	200.4	230.4	260.4	290.4	330.4	375.4	
A35W7	Cooling capacity	165	183	204	228	256	292	326	372	kW
	Power input	55,6	61,4	69,4	78,8	88,3	100,7	113	130	kW
	EER	2,97	2,98	2,94	2,89	2,90	2,90	2,89	2,86	W/W
	SEER*	4,01	4,02	4,12	4,15	4,12	4,11	4,13	4,12	W/W
	Water flow rate	7,88	8,74	9,75	10,9	12,2	14,0	15,6	17,8	l/s
	Pressure drops	36	33	35	36	36	33	34	31	kPa
IR	eXtra low noise setting up (AX)	160.4	180.4	200.4	230.4	260.4	290.4	330.4	375.4	
A35W7	Cooling capacity	162	180	199	223	251	286	320	364	kW
	Power input	56,3	62,2	70,4	80,1	89,4	102	114	132	kW
	EER	2,88	2,89	2,83	2,78	2,81	2,80	2,82	2,77	W/W
	SEER*	4,05	4,11	4,17	4,21	4,13	4,13	4,18	4,15	W/W
	Water flow rate	7,74	8,60	9,51	10,7	12,0	13,7	15,3	17,4	l/s
	Pressure drops	34	32	33	35	35	32	32	29	kPa
IP	Base setting up (AB)	160.4	180.4	200.4	230.4	260.4	290.4	330.4	375.4	
A35W7	Cooling capacity	169	187	208	234	266	301	339	385	kW
	Power input	52,7	58,0	65,3	73,3	83,2	94,0	106	121	kW
	EER	3,22	3,23	3,19	3,19	3,20	3,20	3,20	3,18	W/W
	SEER*	3,96	4,01	4,03	4,11	4,01	4,04	4,11	4,10	W/W
	Water flow rate	8,09	8,95	9,94	11,2	12,7	14,4	16,2	18,4	l/s
	Pressure drops	38	35	36	38	39	35	36	33	kPa
A7W45	Heating capacity	176	196	218	242	279	316	351	401	kW
	Power input	52,6	59,9	66,7	74,6	85,9	97	107	124	kW
	COP	3,34	3,28	3,27	3,24	3,25	3,26	3,28	3,23	W/W
	Water flow rate	8,39	9,37	10,4	11,6	13,3	15,1	16,8	19,2	l/s
Pressure drops	41	38	40	41	43	39	39	36	kPa	
IP	Low noise setting up (AS)	160.4	180.4	200.4	230.4	260.4	290.4	330.4	375.4	
A35W7	Cooling capacity	163	180	200	225	255	289	325	370	kW
	Power input	55,6	61,4	69,2	77,9	87,9	99,6	113	129	kW
	EER	2,93	2,93	2,89	2,89	2,90	2,90	2,88	2,87	W/W
	SEER*	3,91	3,93	3,96	4,02	3,94	3,96	4,03	4,01	W/W
	Water flow rate	7,79	8,60	9,56	10,75	12,2	13,8	15,5	17,7	l/s
	Pressure drops	35	32	34	35	36	32	33	30	kPa
A7W45	Heating capacity	169	188	209	232	268	303	337	385	kW
	Power input	49,6	56,5	63,0	70,5	81,0	91,3	101	117	kW
	COP	3,41	3,33	3,32	3,29	3,31	3,32	3,35	3,29	W/W
	Water flow rate	8,07	8,98	9,99	11,1	12,8	14,5	16,1	18,4	l/s
Pressure drops	37	35	37	37	40	36	36	33	kPa	
IP	eXtra low noise setting up (AX)	160.4	180.4	200.4	230.4	260.4	290.4	330.4	375.4	
A35W7	Cooling capacity	159	176	196	220	250	283	319	362	kW
	Power input	56,3	62,2	70,3	79,2	89,0	101	114	131	kW
	EER	2,82	2,83	2,79	2,78	2,81	2,80	2,81	2,77	W/W
	SEER*	3,94	3,96	4,00	4,05	3,98	4,00	4,07	4,05	W/W
	Water flow rate	7,60	8,41	9,36	10,51	11,9	13,5	15,2	17,3	l/s
	Pressure drops	33	31	32	34	34	31	32	29	kPa
A7W45	Heating capacity	167	186	207	230	265	300	333	381	kW
	Power input	48,0	54,8	61,1	68,5	78,4	89	98	113	kW
	COP	3,48	3,39	3,39	3,36	3,38	3,39	3,40	3,39	W/W
	Water flow rate	7,98	8,89	9,89	11,0	12,7	14,3	15,9	18,2	l/s
Pressure drops	37	34	36	37	39	35	35	32	kPa	

The values are referred to units without options and accessories.

Data declared according to **EN 14511**:

EER (Energy Efficiency Ratio) = ratio of the total cooling capacity to the effective power input of the unit

COP (Coefficient Of Performance) = ratio of the total heating capacity to the effective power input of the unit

SEER (Seasonal Energy Efficiency Ratio) dichiarato secondo EN 14825

A35W7 = source : air in 35°C d.b. / plant : water in 12°C out 7°C

A7W45 = source : air in 7°C d.b. 6°C w.b. / plant : water in 40°C out 45°C

* Calculated value with option modulating fans regulation

Acoustic performances

Base setting up (AB)	160.4	180.4	200.4	230.4	260.4	290.4	330.4	375.4	
Sound power level ^(E)	91	92	92	92	93	94	94	95	dB(A)
Sound pressure level at 1 meter	72	73	73	73	74	75	74	75	dB(A)
Sound pressure level at 5 meters	64	65	65	65	66	67	67	68	dB(A)
Sound pressure level at 10 meters	59	60	60	60	61	62	62	63	dB(A)
Low noise setting up (AS)	160.4	180.4	200.4	230.4	260.4	290.4	330.4	375.4	
Sound power level ^(E)	85	86	86	86	87	88	88	89	dB(A)
Sound pressure level at 1 meter	66	67	67	67	68	69	68	69	dB(A)
Sound pressure level at 5 meters	58	59	59	59	60	61	61	62	dB(A)
Sound pressure level at 10 meters	53	54	54	54	55	56	56	57	dB(A)
eXtra low noise setting up (AX)	160.4	180.4	200.4	230.4	260.4	290.4	330.4	375.4	
Sound power level ^(E)	82	83	83	83	84	85	85	86	dB(A)
Sound pressure level at 1 meter	63	64	64	64	65	66	65	66	dB(A)
Sound pressure level at 5 meters	55	56	56	56	57	58	58	59	dB(A)
Livello di pressione sonora a 10 metri	50	51	51	51	52	53	53	54	dB(A)

(E): EUROVENT certified data

The acoustic performances are referred to units operating in cooling mode at nominal conditions A35W7.

Unit placed in free field on reflecting surface (directional factor equal to 2).

The sound power level is measured according to ISO 9614 standard.

The sound pressure level is calculated according to ISO 3744 and is referred to a distance of 1/5/10 metres from the external surface of the unit.

Technical data

Unit	160.4	180.4	200.4	230.4	260.4	290.4	330.4	375.4		
Power supply	400 - 3 - 50								V-ph-Hz	
Compressor type	scroll								-	
N° compressors / N° refrigerant circuits	4 / 2								n°	
Plant side heat exchanger type	stainless steel brazed plates								-	
Source side heat exchanger type	finned coil								-	
Fans type	axial								-	
N° fans	4					6		8	n°	
Tank volume	325					710				l
Hydraulic fittings	3" VICTAULIC					4" VICTAULIC				-

Electrical data

Standard unit	160.4	180.4	200.4	230.4	260.4	290.4	330.4	375.4	
FLA - Full load current at maximum tolerated conditions	140	151	177	193	217	243	269	314	A
FLI - Full load power input at maximum tolerated conditions	76	87	107	118	133	148	163	186	kW
MIC - Maximum instantaneous current of the unit	283	340	347	355	379	469	495	510	A
MIC SS - Maximum instantaneous current of the unit with soft starter options	213	250	263	271	295	354	380	404	A
Unit with high head modulating pump	160.4	180.4	200.4	230.4	260.4	290.4	330.4	375.4	
FLA - Full load current at maximum tolerated conditions	149	160	187	203	227	256	282	327	A
FLI - Full load power input at maximum tolerated conditions	81	91	113	124	139	156	171	194	kW
MIC - Maximum instantaneous current of the unit	292	348	357	365	389	482	508	524	A
MIC SS - Maximum instantaneous current of the unit with soft starter options	222	258	273	281	305	368	394	417	A

Operative range

Temperature	Unit type	Cooling		Heating		
		min	max	min	max	
Outdoor air inlet temperature	IR, BR, IP, BP	-10*	52**	-15	40*	(°C)
Water outlet temperature	IR, IP	5	25	30	55	(°C)
Water outlet temperature	BR, BP	-12	5	30	55	(°C)
Water outlet temperature (VD)	IR, BR, IP, BP	30	70	30	70	(°C)
Water outlet temperature (VR)	IR, BR	30	55	-	-	(°C)

* with fans modulating control option (condensation / evaporation control)

** with ATC outdoor high temperature protection function

VD and VR versions

These units allow to recover the heating power, otherwise wasted on air, through an additional heat exchanger.

The **Desuperheater Version (VD)** allow the hot water production at temperatures between 30 and 70°C through the partial heat recovery of the condensation heat.

The **Total Recovery Version (VR)** allows the cold water production and, at the same time, the hot water production at temperatures between 30 and 55°C through the total recovery of the condensation heat.

Desupeheater Version (VD) - NET NOMINAL performances

IR	Base setting up (AB)	160.4	180.4	200.4	230.4	260.4	290.4	330.4	375.4	
A35W7 - W45	Cooling capacity	177	197	218	244	275	312	350	398	kW
	Total power input	53,1	58,5	66,1	74,7	84,5	96	106	123	kW
	EER	3,33	3,36	3,30	3,27	3,25	3,24	3,29	3,22	W/W
	HRE	4,18	4,22	4,17	4,15	4,10	4,11	4,17	4,09	W/W
	Water flow rate	8,55	9,49	10,5	11,8	13,3	15,1	16,9	19,2	l/s
	Water pressure drop	62	63	69	66	71	74	63	68	kPa
	Heating recovery capacity	45,0	50,3	57,6	66,2	72,0	83,4	94,0	107	kW
	Water flow rate recovery	2,15	2,40	2,75	3,16	3,44	3,98	4,49	5,11	l/s
	Water pressure drop recovery	5	6	8	10	12	16	20	26	kPa

IP	Base setting up (AB)	160.4	180.4	200.4	230.4	260.4	290.4	330.4	375.4	
A35W7 - W45	Cooling capacity	174	193	214	241	274	309	349	396	kW
	Total power input	53,0	58,4	65,9	73,8	84,1	95	106	122	kW
	EER	3,29	3,31	3,25	3,26	3,25	3,25	3,28	3,23	W/W
	HRE	4,14	4,17	4,12	4,15	4,11	4,12	4,16	4,10	W/W
	Water flow rate	8,42	9,31	10,34	11,6	13,2	15,0	16,8	19,1	l/s
	Water pressure drop	60	61	67	64	70	73	62	67	kPa
	Heating recovery capacity	45,0	50,3	57,5	65,4	71,6	82,3	94,0	106	kW
	Water flow rate recovery	2,15	2,40	2,75	3,12	3,42	3,93	4,49	5,06	l/s
	Water pressure drop recovery	5	6	8	10	12	16	20	26	kPa

Total Recovery Version (VR) - NET NOMINAL performances

IR	Base setting up (AB)	160.4	180.4	200.4	230.4	260.4	290.4	330.4	375.4	
A35W7 - W45	Cooling capacity	179	198	220	246	277	315	353	402	kW
	Total power input	45,5	50,8	58,4	66,9	73,1	84,8	95	108	kW
	EER	3,93	3,91	3,77	3,68	3,79	3,72	3,72	3,72	W/W
	HRE	8,81	8,77	8,50	8,32	8,54	8,39	8,40	8,38	W/W
	Water flow rate	8,63	9,58	10,6	11,9	13,4	15,3	17,1	19,4	l/s
	Water pressure drop	64	64	70	67	72	76	65	69	kPa
	Heating recovery capacity	222	247	276	310	347	396	444	505	kW
	Water flow rate recovery	10,6	11,8	13,2	14,8	16,6	18,9	21,2	24,1	l/s
	Water pressure drop recovery	49	47	48	47	49	51	51	53	kPa

Data declared according to EN 14511. The values are referred to units without options and accessories.

EER (Energy Efficiency Ratio) = ratio of the total cooling capacity to the effective power input of the unit

HRE (Heat Recovery Efficiency) = ratio of the total capacity of the system (heating plus cooling capacity) to the effective power input

A35W7 - W45 = source : air in 35°C d.b. / plant : water in 12°C out 7°C / Recovery : water in 40°C out 45°C

CONTROL SYSTEM

The units are equipped with a controller designed to ensure energy saving and unit efficiency. Available functions :

- ATC outdoor high temperature protection function
- Dynamic defrost
- Sound management
- Climatic control in heating and in cooling mode
- Double set point function
- Demand limit
- Integrative heating
- Remote stand by
- Remote cooling-heating



DIMENSIONS - MINIMUM OPERATING AREA - WEIGHT

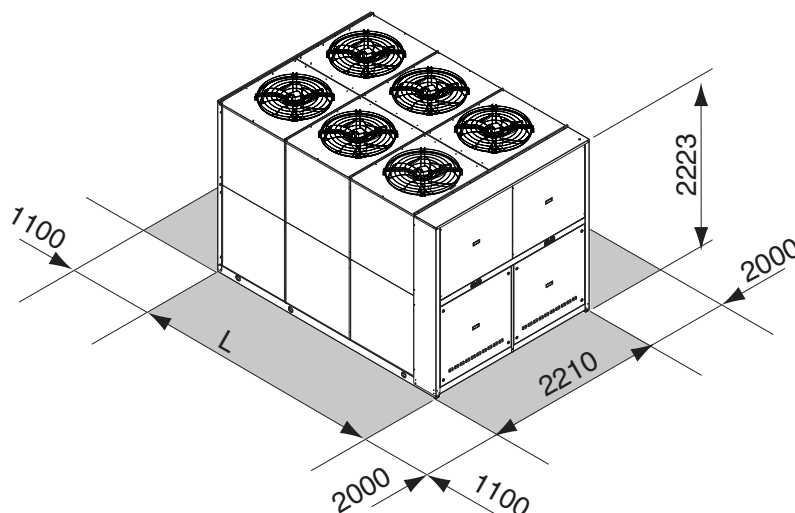

	160.4	180.4	200.4	230.4	260.4	290.4	330.4	375.4	
L	3164	3164	3164	3164	3164	4097	4097	4097	mm
Operating maximum weight*	2512	2712	2957	3122	3214	3787	3948	4046	kg

* Weight refers to the unit IP with tank and pumping module 2 pumps.

> RMP² HE

AIR-WATER HEAT PUMPS FOR INDOOR INSTALLATION



Efficiency capacity in heating mode - Heat pump low temperature - Medium temperature level

Acoustic setting up	19.1	22.1	26.1	30.1	35.1	40.1
AB	A+	A+	A+	A	A+	A+
AS	A+	A+	A+	A	A+	A+

NOTA: Declared according to European regulation 811/2013. The values are referred to units without options and accessories.

Available range

Unit type

- IP** Heat pump
(reversible on the refrigerant side)
- BP** Heat pump Brine
(reversible on the refrigerant side)

Versions

- VB** Base Version
- VP** Pump version
- VA** Tank version

Acoustic setting up

- AB** Base setting up
- AS** Low noise setting up

Unit description

This series of air-water heat pumps satisfies the cooling and heating requirements of residential plants of small and medium size.

All the units are suitable for indoor installation and can be applied to fan coil plants, radiant floor plants and high efficiency radiators plants.

The refrigerant circuit, contained in a compartment protected from the air flow to simplify the maintenance operations, is equipped with scroll compressor mounted on damper supports, brazed plate heat exchanger, thermostatic expansion valve, reverse cycle valve, centrifugal fans (plug fan), finned coil made of copper pipes and

aluminium louvered fins. The circuit is protected by high and low pressure switches and differential pressure switch on the plate heat exchanger.

The plate heat exchanger and all the hydraulic pipes are thermally insulated in order to avoid condensate generation and to reduce thermal losses.

All the units are equipped with variable speed fans control that allows the units to operate with low outdoor temperatures in cooling and high outdoor temperature in heating and permits to reduce noise emissions in such operating conditions.

The low noise acoustic setting up (AS) is obtained, starting from the base setting up (AB), reducing the rotational speed of the fans and mounting sound jackets on the compressors.

All the units are provided with a phase presence and correct sequence controller device.

All the units are accurately built and individually tested in the factory. Only electric and hydraulic connections are required for installation.

Options

Storing and pumping module

- not present (VB - base version)
- standard, high head or modulating pump (VP - pump version)
- tank and standard, high head or modulating pump (VA - tank version)

Integrative electrical heaters

- not present
- standard in the tank

Compressor starting

- standard (contactors)
- soft starter

Fans control

- on-off control
- modulating control (condensation / evaporation control)

Electrical loads protection

- fuses
- thermal magnetic circuit breakers

Compressor power factor correction

Accessories

Rubber vibration dampers

Coil protection grille

Remote control

Modbus serial interface on RS485

Programmer clock

Phase sequence and voltage controller

Water flow switch

Manometer

Oil crankcase electrical heater

Pressure transducer

Coil protection kit for shipment

Outdoor air sensor

NET NOMINAL performances - Standard plants - EUROVENT certified data

IP	Base setting up (AB)	19.1	22.1	26.1	30.1	35.1	40.1	
A35W7	Cooling capacity	19,9	22,3	25,9	30,9	34,8	40,5	kW
	Power input	6,42	7,17	8,25	9,96	11,20	12,95	kW
	EER	3,10	3,11	3,14	3,10	3,11	3,13	W/W
	SEER	3,44	3,47	3,59	3,36	3,36	3,42	W/W
	Water flow rate	3442	3859	4478	5337	6020	7008	l/h
	Pressure drops	26	24	23	27	28	26	kPa
A7W45	Heating capacity	21,1	24,0	27,8	32,3	37,0	42,7	kW
	Power input	6,42	7,14	8,25	10,01	11,21	12,83	kW
	COP	3,29	3,36	3,37	3,22	3,29	3,33	W/W
	Water flow rate	3612	4096	4763	5517	6320	7310	l/h
	Pressure drops	29	27	26	29	31	28	kPa
	A35W7	Low noise setting up (AS)	19.1	22.1	26.1	30.1	35.1	40.1
Cooling capacity		19,1	21,4	24,9	29,7	33,5	39,0	kW
Power input		6,91	7,74	8,91	10,75	12,06	13,74	kW
EER		2,76	2,77	2,79	2,76	2,77	2,84	W/W
SEER		3,20	3,23	3,31	3,21	3,21	3,25	W/W
Water flow rate		3302	3700	4303	5129	5785	6748	l/h
A7W45	Low noise setting up (AS)	19.1	22.1	26.1	30.1	35.1	40.1	
	Heating capacity	20,1	22,9	26,6	31,0	35,2	40,8	kW
	Power input	6,23	6,90	8,00	9,70	10,87	12,42	kW
	COP	3,22	3,32	3,32	3,20	3,24	3,28	W/W
	Water flow rate	3422	3902	4533	5261	6016	6963	l/h
	Pressure drops	26	25	23	26	28	26	kPa

The values are referred to units without options and accessories.

Data declared according to **EN 14511**:

EER (Energy Efficiency Ratio) = ratio of the total cooling capacity to the effective power input of the unit

COP (Coefficient Of Performance) = ratio of the total heating capacity to the effective power input of the unit

SEER (Seasonal Energy Efficiency Ratio) dichiarato secondo EN 14825

A35W7 = source : air in 35°C d.b. / plant : water in 12°C out 7°C

A7W45 = source : air in 7°C d.b. 6°C w.b. / plant : water in 40°C out 45°C

Acoustic performances

Base setting up (AB)	19.1	22.1	26.1	30.1	35.1	40.1	
Sound power level ^(E)	76	76	77	80	81	81	dB(A)
Sound pressure level at 1 meter	60	60	61	64	65	65	dB(A)
Sound pressure level at 5 meters	50	50	51	54	55	55	dB(A)
Sound pressure level at 10 meters	45	45	46	49	49	50	dB(A)
Low noise setting up (AS)	19.1	22.1	26.1	30.1	35.1	40.1	
Sound power level ^(E)	74	74	75	78	79	79	dB(A)
Sound pressure level at 1 meter	58	58	59	62	63	63	dB(A)
Sound pressure level at 5 meters	48	48	49	52	53	53	dB(A)
Sound pressure level at 10 meters	43	43	44	47	47	48	dB(A)

(E): EUROVENT certified data

The acoustic performances are referred to units operating in cooling mode at nominal conditions A35W7.

Unit placed in free field on reflecting surface (directional factor equal to 2).

The sound power level is measured according to ISO 9614 standard.

The sound pressure level is calculated according to ISO 3744 and is referred to a distance of 1/5/10 metres from the external surface of the unit.

Technical data

Unit	19.1	22.1	26.1	30.1	35.1	40.1	
Power supply	400 - 3+N - 50						V-ph-Hz
Compressor type	scroll						-
N° compressors / N° refrigerant circuits	1 / 1						n°
Plant side heat exchanger type	stainless steel brazed plates						-
Source side heat exchanger type	finned coil						-
Fans type	centrifugal (plug fan)						-
N° fans	1						n°
Tank volume	85						l
Hydraulic fittings	1"1/4 GAS						-

Electrical data

Standard unit	19.1	22.1	26.1	30.1	35.1	40.1	
FLA - Full load current at maximum tolerated conditions	18,7	20,5	22,0	24,4	26,8	30,8	A
FLI - Full load power input at maximum tolerated conditions	11,3	12,8	14,1	15,5	17,0	19,3	kW
MIC - Maximum instantaneous current of the unit	118	128	141	158	162	193	A
MIC SS - Maximum instantaneous current of the unit with soft starter options	61	67	74	85	87	106	A
Unit with standard modulating pump	19.1	22.1	26.1	30.1	35.1	40.1	
FLA - Full load current at maximum tolerated conditions	20,2	22,0	23,5	26,0	28,4	32,4	A
FLI - Full load power input at maximum tolerated conditions	11,9	13,4	14,7	16,3	17,8	20,1	kW
MIC - Maximum instantaneous current of the unit	120	130	143	160	164	195	A
MIC SS - Maximum instantaneous current of the unit with soft starter options	62	68	76	86	89	107	A
Unit with high head modulating pump	19.1	22.1	26.1	30.1	35.1	40.1	
FLA - Full load current at maximum tolerated conditions	20,4	22,2	23,7	27,4	29,8	33,8	A
FLI - Full load power input at maximum tolerated conditions	12,2	13,6	15,0	17,1	18,6	20,9	kW
MIC - Maximum instantaneous current of the unit	120	130	143	161	165	196	A
MIC SS - Maximum instantaneous current of the unit with soft starter options	62	68	76	88	90	109	A

Operating range

Temperature	Unit type	Heating		Cooling		
		min	max	min	max	
Outdoor air inlet temperature	IP, BP	-10*	50	-15	42	(°C)
Water outlet temperature	IP	5	25	30	55	(°C)
Water outlet temperature	BP	-12	5	30	55	(°C)

* with fans modulating control option (condensation / evaporation control)

Aeraulic performances

Unit	19.1	22.1	26.1	30.1	35.1	40.1	
Available static head	150	150	150	150	150	150	Pa

CONTROL SYSTEM

The unit is managed by a microprocessor controller to which, through a wiring board, all the electrical loads and the control devices are connected. The user interface is realized by a display and four buttons that allow to view and, if necessary, modify all the operating parameters of the unit. It's available, as an accessory, a remote control that reports all the functionalities of the user interface placed on the unit.

The main functions available are :

- water temperature management (through set point adjustment)
- adaptive function
- climatic control in heating and in cooling mode, automatic set point adjustment according to outdoor air temperature (if present "outdoor air sensor" accessory)
- dynamic defrost cycle management according to outdoor air temperature (if present "outdoor air sensor" accessory)
- alarm memory management and diagnostic

- fans management by means of continuous rotational speed control
- pump management
- integrative electrical heaters management in heating mode
- compressor and pump operating hours recording
- serial communication through Modbus protocol
- remote stand by
- remote cooling-heating
- general alarm digital output



DIMENSIONS AND MINIMUM OPERATING AREA

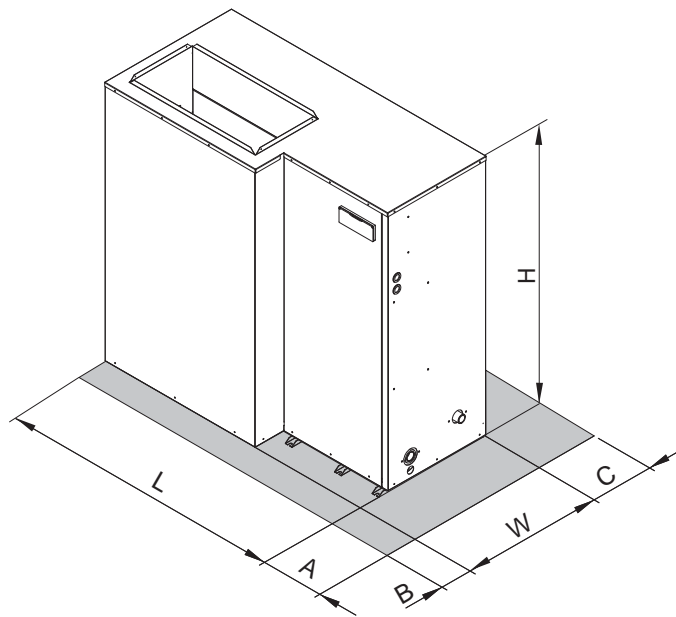

	19.1	22.1	26.1	30.1	35.1	40.1	
L		1494			1704		mm
W		744			744		mm
H		1453			1453		mm
A		400			400		mm
B		450			450		mm
C		200			200		mm
Maximum weight operation (VA Tank version)	399	402	426	433	459	461	kg

> RGC

AIR-WATER CHILLERS AND HEAT PUMPS FOR INDOOR INSTALLATION



Efficiency capacity in heating mode - Heat pump low temperature - Medium temperature level

Acoustic setting up	40.2	50.2	60.2	70.2	80.2
AB	A+	A+	A+	A+	A+
AS	A+	A+	A+	A+	A+

NOTA: Declared according to European regulation 811/2013. The values are referred to units without options and accessories.

Available range

Unit type

IR	Chiller
IP	Heat pump (reversible on the refrigerant side)
BR	Chiller Brine
BP	Heat pump Brine (reversible on the refrigerant side)

Version

VB	Base version
VD	Desuperheater version
VR	Total recovery version

Acoustic setting up

AB	Base setting up
AS	Low noise setting up

Source temperature level

M	Medium temperature level
A	High temperature level

Unit description

This series of air-water chillers and heat pumps satisfies the cooling and heating requirements of residential plants of medium size.

All the units are suitable for indoor installation and can be applied to fan coil plants, radiant floor plants and high efficiency radiators plants.

The refrigerant circuit, contained in a compartment protected from the air flow to simplify the maintenance operations, is equipped with scroll compressors mounted on damper supports, brazed plate heat exchanger, thermostatic expansion valve (standard for IR) or electronic expansion valve (standard for IP / option

for IR), reverse cycle valve, dehydrator filter, double inlet centrifugal fans with forward curved blades, finned coil made of copper pipes and aluminium louvered fins with subcooling section. The circuit is protected by a safety gas valve, high and low pressure switches and differential pressure switch on the plate heat exchanger. The plate heat exchanger and all the hydraulic pipes are thermally insulated in order to avoid condensate generation and to reduce thermal losses.

All the units can be equipped with variable speed fans control that allows the units to operate with low outdoor temperatures in cooling and high outdoor temperature in heating and permits to reduce noise emissions in such operating conditions.

The low noise acoustic setting up (AS) is obtained, starting from the base setting up (AB), mounting sound jackets on the compressors and the technical compartment is clad with soundproofing material of suitable thickness.

All the units are supplied with a management and control electrical panel containing general switch, phase presence and correct sequence controller, microprocessor controller with display and all the other electrical components with IP54 minimum protection degree.

All the units are accurately built and individually tested in the factory. Only electric and hydraulic connections are required for installation.

Options

Storing and pumping module available in the configurations :

- Storage tank arranged as buffer on the flow or as primary-secondary buffer
- 1 or 2 pumps
- standard or high head pump
- modulating pump

Expansion valve

- thermostatic
- electronic (standard for IP)

Compressor starting

- standard (contactors)
- soft starter

Fans control

- on-off control
- modulating control (condensation / evaporation control)

Compressor power factor correction

Electrical load protection

- fuses
- thermal magnetic circuit breakers

Coil condensate tray

(standard for IP)

Accessories

Rubber vibration dampers

Spring vibration dampers

Coil protection grilles

Tank antifreeze electrical heater

Remote control

Modbus serial interface on RS485

Programmer clock

Phase sequence and voltage controller

Low temperature kit (standard for IP)

High and low pressure gauges

High temperature thermostat

Outdoor air sensor

Water flow switch

Victaulic hydraulic fittings

NET NOMINAL performances - Standard plants - EUROVENT certified data

IR	Base setting up (AB)	40.2	50.2	60.2	70.2	80.2	90.2	100.2	115.2	130.2	145.2	160.2	180.2	200.2	
A35W7	Cooling capacity	45,0	53,0	58,1	68,2	78,1	90,3	101	111	125	142	157	179	198	kW
	Power input	15,7	18,8	20,8	24,1	28,0	32,5	35,9	39,9	45,1	51,5	57,1	64,6	71,6	kW
	EER	2,87	2,82	2,79	2,83	2,79	2,78	2,81	2,78	2,77	2,76	2,75	2,77	2,77	W/W
	SEER*	3,85	3,86	3,84	3,86	3,88	3,85	3,83	3,85	3,86	3,83	3,85	3,87	3,84	W/W
	Water flow rate	2,16	2,56	2,80	3,29	3,76	4,35	4,87	5,35	6,02	6,83	7,55	8,60	9,56	l/s
	Pressure drops	40	56	55	51	50	48	46	44	48	47	48	48	50	kPa
IR	Low noise setting up (AS)	40.2	50.2	60.2	70.2	80.2	90.2	100.2	115.2	130.2	145.2	160.2	180.2	200.2	
A35W7	Cooling capacity	45,0	53,0	58,1	68,2	78,1	90,3	101	111	125	142	157	179	198	kW
	Power input	15,7	18,8	20,8	24,1	28,0	32,5	35,9	39,9	45,1	51,5	57,1	64,6	71,6	kW
	EER	2,87	2,82	2,79	2,83	2,79	2,78	2,81	2,78	2,77	2,76	2,75	2,77	2,77	W/W
	SEER	3,80	3,81	3,80	3,81	3,83	3,81	3,80	3,80	3,80	3,80	3,80	3,81	3,80	W/W
	Water flow rate	2,16	2,56	2,80	3,29	3,76	4,35	4,87	5,35	6,02	6,83	7,55	8,60	9,56	l/s
	Pressure drops	40	56	55	51	50	48	46	44	48	47	48	48	50	kPa
IP	Base setting up (AB)	40.2	50.2	60.2	70.2	80.2	90.2	100.2	115.2	130.2	145.2	160.2	180.2	200.2	
A35W7	Cooling capacity	43,5	52,4	57,0	66,7	73,6	88,5	98	109	121	137	153	177	196	kW
	Power input	15,5	19,0	20,7	24,1	27,0	32,3	35,7	39,8	44,5	50,3	56,3	63,5	71,2	kW
	EER	2,81	2,76	2,75	2,77	2,73	2,74	2,75	2,74	2,72	2,72	2,72	2,79	2,75	W/W
	SEER	3,53	3,60	3,46	3,57	3,66	3,45	3,44	3,46	3,50	3,47	3,53	3,50	3,52	W/W
	Water flow rate	2,09	2,53	2,75	3,21	3,54	4,26	4,73	5,26	5,83	6,59	7,36	8,50	9,46	l/s
	Pressure drops	37	55	53	49	44	46	43	43	45	44	46	47	49	kPa
A7W45	Heating capacity	48,1	58,1	63,2	74,5	83,0	99,6	110	125	136	154	173	197	216	kW
	Power input	15,6	19,1	20,9	24,4	27,6	33,5	35,9	41,1	44,9	51,8	56,9	65,1	71,7	kW
	COP	3,08	3,04	3,02	3,05	3,01	2,97	3,06	3,04	3,03	2,97	3,04	3,03	3,01	W/W
	Water flow rate	2,28	2,75	2,99	3,53	3,93	4,72	5,21	5,92	6,45	7,31	8,17	9,32	10,2	l/s
	Pressure drops	45	65	63	59	55	57	53	54	55	54	56	56	57	kPa
IP	Low noise setting up (AS)	40.2	50.2	60.2	70.2	80.2	90.2	100.2	115.2	130.2	145.2	160.2	180.2	200.2	
A35W7	Cooling capacity	43,5	52,4	57,0	66,7	73,6	88,5	98	109	121	137	153	177	196	kW
	Power input	15,5	19,0	20,7	24,1	27,0	32,3	35,7	39,8	44,5	50,3	56,3	63,5	71,2	kW
	EER	2,81	2,76	2,75	2,77	2,73	2,74	2,75	2,74	2,72	2,72	2,72	2,79	2,75	W/W
	SEER	3,50	3,56	3,41	3,52	3,60	3,42	3,42	3,43	3,45	3,41	3,48	3,45	3,47	W/W
	Water flow rate	2,09	2,53	2,75	3,21	3,54	4,26	4,73	5,26	5,83	6,59	7,36	8,50	9,46	l/s
	Pressure drops	37	55	53	49	44	46	43	43	45	44	46	47	49	kPa
A7W45	Heating capacity	48,1	58,1	63,2	74,5	83,0	99,6	110	125	136	154	173	197	216	kW
	Power input	15,6	19,1	20,9	24,4	27,6	33,5	35,9	41,1	44,9	51,8	56,9	65,1	71,7	kW
	COP	3,08	3,04	3,02	3,05	3,01	2,97	3,06	3,04	3,03	2,97	3,04	3,03	3,01	W/W
	Water flow rate	2,28	2,75	2,99	3,53	3,93	4,72	5,21	5,92	6,45	7,31	8,17	9,32	10,2	l/s
	Pressure drops	45	65	63	59	55	57	53	54	55	54	56	56	57	kPa

The values are referred to units without options and accessories.

Data declared according to EN 14511:

EER (Energy Efficiency Ratio) = ratio of the total cooling capacity to the effective power input of the unit

COP (Coefficient Of Performance) = ratio of the total heating capacity to the effective power input of the unit

SEER (Seasonal Energy Efficiency Ratio) dichiarato secondo EN 14825

A35W7 = source : air in 35°C d.b. / plant : water in 12°C out 7°C

A7W45 = source : air in 7°C d.b. 6°C w.b. / plant : water in 40°C out 45°C

* Calculated value with option modulating fans regulation

Acoustic performances

Base setting up (AB)	40.2	50.2	60.2	70.2	80.2	90.2	100.2	115.2	130.2	145.2	160.2	180.2	200.2	
Sound power level ^(E)	88	88	89	89	89	91	91	91	96	97	97	98	98	dB(A)
Sound pressure level at 1 meter	70	70	71	71	71	73	73	73	78	79	79	80	80	dB(A)
Sound pressure level at 5 meters	61	61	62	62	62	65	65	65	69	70	70	71	71	dB(A)
Sound pressure level at 10 meters	56	56	57	57	57	59	59	59	64	65	65	66	66	dB(A)
Low noise setting up (AS)	40.2	50.2	60.2	70.2	80.2	90.2	100.2	115.2	130.2	145.2	160.2	180.2	200.2	
Sound power level ^(E)	85	85	86	86	86	88	88	88	93	94	94	95	95	dB(A)
Sound pressure level at 1 meter	67	67	68	68	68	70	70	70	75	76	76	77	77	dB(A)
Sound pressure level at 5 meters	58	58	59	59	59	62	62	62	66	67	67	68	68	dB(A)
Sound pressure level at 10 meters	53	53	54	54	54	56	56	56	61	62	62	63	63	dB(A)

(E): EUROVENT certified data

The acoustic performances are referred to units operating in cooling mode at nominal conditions A35W7.

Unit placed in free field on reflecting surface (directional factor equal to 2).

The sound power level is measured according to ISO 9614 standard.

The sound pressure level is calculated according to ISO 3744 and is referred to a distance of 1/5/10 metres from the external surface of the unit.

Technical data

Unit	40.2	50.2	60.2	70.2	80.2	90.2	100.2	115.2	130.2	145.2	160.2	180.2	200.2	
Power supply	400 - 3 - 50													V-ph-Hz
Compressor type	scroll													-
N° compressors / N° refrigerant circuits	2 / 1													n°
Plant side heat exchanger type	stainless steel brazed plates													-
Source side heat exchanger type	finned coil													-
Fans type	centrifugal													-
N° fans	1			2			3			4			n°	
Tank volume	200			400			460						l	
Hydraulic fittings	2" VICTAULIC						2" 1/2 VICTAULIC						-	

Electrical data

Standard unit	40.2	50.2	60.2	70.2	80.2	90.2	100.2	115.2	130.2	145.2	160.2	180.2	200.2	
FLA - Full load current at maximum tolerated conditions	43,2	48,8	56,7	62,1	73,0	80,5	95,0	103	117	145	158	188	199	A
FLI - Full load power input at maximum tolerated conditions	25,2	28,0	33,0	35,6	40,8	47,3	58,3	63,8	72,8	88,7	96,3	113	120	kW
MIC - Maximum instantaneous current of the unit	137	147	152	177	216	269	264	272	278	370	383	384	420	A
MIC SS - Maximum instantaneous current of the unit with soft starter options	92,4	99,4	105	121	147	179	180	188	194	222	268	277	301	A
Unit with high head modulating pump	40.2	50.2	60.2	70.2	80.2	90.2	100.2	115.2	130.2	145.2	160.2	180.2	200.2	
FLA - Full load current at maximum tolerated conditions	49,3	54,9	62,8	68,2	79,1	86,6	101	112	126	153	166	198	209	A
FLI - Full load power input at maximum tolerated conditions	28,7	31,5	36,5	39,1	44,3	50,8	61,8	68,4	77,3	93,2	101	119	126	kW
MIC - Maximum instantaneous current of the unit	143	153	158	183	222	275	270	281	287	378	392	394	430	A
MIC SS - Maximum instantaneous current of the unit with soft starter options	98,5	105	111	127	153	185	186	197	203	231	277	287	311	A

Operative range

Temperature	Unit type	Cooling		Heating		
		min	max	min	max	
Outdoor air inlet temperature	IR, BR, IP, BP	-10*	52**	-10	40*	(°C)
Water outlet temperature	IR, IP	5	25	30	55	(°C)
Water outlet temperature	BR, BP	-12	5	30	55	(°C)
Water outlet temperature (VD)	IR, BR, IP, BP	30	70	30	70	(°C)
Water outlet temperature (VR)	IR, BR	30	55	-	-	(°C)

* with fans modulating control option (condensation / evaporation control)

** with ATC outdoor high temperature protection fuccion

Aeraulic performance

Unit	40.2	50.2	60.2	70.2	80.2	90.2	100.2	115.2	130.2	145.2	160.2	180.2	200.2	
Available static head	150	150	150	150	150	150	150	150	150	150	150	150	150	Pa

VD and VR versions

These units allow to recover the heating power, otherwise wasted on air, through an additional heat exchanger.

The **Desuperheater Version (VD)** allow the hot water production at temperatures between 30 and 70°C through the partial heat recovery of the condensation heat.

The **Total Recovery Version (VR)** allows the cold water production and, at the same time, the hot water production at temperatures between 30 and 55°C through the total recovery of the condensation heat.

Desupeheater Version (VD) - NET NOMINAL performances

IR	Base setting up (AB)	40.2	50.2	60.2	70.2	80.2	90.2	100.2	115.2	130.2	145.2	160.2	180.2	200.2	
A35W7 - W45	Cooling capacity	46,8	55,1	60,3	71	81,1	93,8	105	115	130	148	163	185	206	kW
	Total power input	15,3	18,3	20,3	23,4	27,3	31,8	35,1	38,9	44	50,3	55,8	63	69,9	kW
	EER	3,05	3	2,98	3,03	2,97	2,95	2,99	2,96	2,95	2,94	2,92	2,94	2,95	W/W
	HRE	3,93	3,86	3,84	3,88	3,83	3,8	3,86	3,85	3,83	3,81	3,8	3,82	3,83	W/W
	Water flow rate	2,25	2,66	2,91	3,42	3,91	4,52	5,06	5,54	6,26	7,12	7,84	8,93	9,94	l/s
	Water pressure drop	43	60	59	55	54	52	50	47	52	51	52	52	54	kPa
	Heating recovery capacity	13,5	15,7	17,6	20	23,6	27,1	30,4	34,4	38,4	44	49,3	55,4	61,3	kW
	Water flow rate recovery	0,65	0,75	0,84	0,96	1,13	1,29	1,45	1,64	1,83	2,1	2,36	2,65	2,93	l/s
	Water pressure drop recovery	6	9	11	14	19	15	18	11	14	18	22	18	21	kPa
	IP	Base setting up (AB)	40.2	50.2	60.2	70.2	80.2	90.2	100.2	115.2	130.2	145.2	160.2	180.2	200.2
A35W7 - W45	Cooling capacity	45,3	54,5	59,3	69,3	76,5	92,1	102	113	126	143	159	183	204	kW
	Total power input	15,1	18,5	20,1	23,5	26,4	31,5	34,9	38,7	43,4	49,1	54,9	62,1	69,5	kW
	EER	3	2,94	2,94	2,95	2,9	2,92	2,93	2,92	2,9	2,91	2,89	2,95	2,94	W/W
	HRE	3,86	3,76	3,79	3,78	3,77	3,75	3,77	3,78	3,76	3,77	3,75	3,8	3,77	W/W
	Water flow rate	2,18	2,63	2,86	3,34	3,68	4,43	4,92	5,45	6,07	6,88	7,64	8,84	9,84	l/s
	Water pressure drop	41	59	57	53	48	50	47	46	49	48	49	51	53	kPa
	Heating recovery capacity	13	15,2	17	19,4	22,9	26,2	29,2	33,2	37,1	42,4	47,5	52,4	58,1	kW
	Water flow rate recovery	0,62	0,73	0,81	0,93	1,09	1,25	1,4	1,59	1,77	2,03	2,27	2,5	2,78	l/s
	Water pressure drop recovery	6	8	10	13	18	14	17	10	13	17	21	16	19	kPa

Total Recovery Version (VR) - NET NOMINAL performances

IR	Base setting up (AB)	40.2	50.2	60.2	70.2	80.2	90.2	100.2	115.2	130.2	145.2	160.2	180.2	200.2	
A35W7 - W45	Cooling capacity	46,8	55,1	60,3	71	81,1	93,8	105	115	130	148	163	185	206	kW
	Total power input	13,9	16,9	18,4	21,4	25,3	27,9	31,1	35	40	44,4	49,9	55,3	62,1	kW
	EER	3,36	3,25	3,28	3,31	3,2	3,36	3,38	3,29	3,25	3,33	3,26	3,35	3,32	W/W
	HRE	7,67	7,46	7,52	7,58	7,35	7,67	7,71	7,52	7,45	7,61	7,47	7,65	7,59	W/W
	Water flow rate	2,25	2,66	2,91	3,42	3,91	4,52	5,06	5,54	6,26	7,12	7,84	8,93	9,94	l/s
	Water pressure drop	43	60	59	55	54	52	50	47	52	51	52	52	54	kPa
	Heating recovery capacity	60	71,2	77,8	91,4	105	120	135	148	168	190	210	238	265	kW
	Water flow rate recovery	2,87	3,4	3,72	4,37	5,02	5,73	6,45	7,07	8,03	9,08	10	11,4	12,7	l/s
	Water pressure drop recovery	35	49	41	45	50	48	52	47	52	51	52	55	55	kPa

Data declared according to EN 14511. The values are referred to units without options and accessories.

EER (Energy Efficiency Ratio) = ratio of the total cooling capacity to the effective power input of the unit

HRE (Heat Recovery Efficiency) = ratio of the total capacity of the system (heating plus cooling capacity) to the effective power input

A35W7 - W45 = source : air in 35°C d.b. / plant : water in 12°C out 7°C / Recovery : water in 40°C out 45°C

CONTROL SYSTEM

The units are equipped with a controller designed to ensure energy saving and unit efficiency. Available functions :

- Adaptive function
- Dynamic defrost
- Sound management
- Climatic control in heating and in cooling mode
- Economy function
- Demand limit
- Integrative heating
- Remote stand by
- Remote cooling-heatingg



DIMENSIONS - MINIMUM OPERATING AREA - WEIGHT

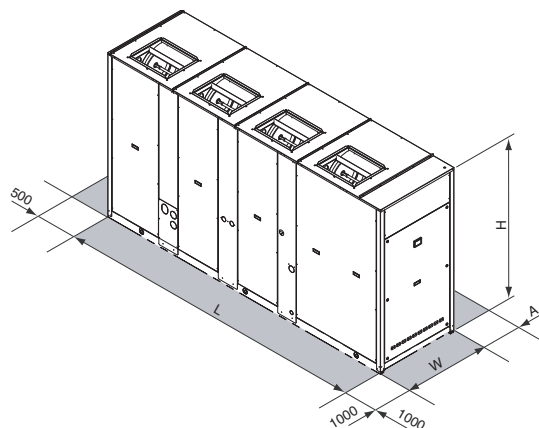

	40.2	50.2	60.2	70.2	80.2	90.2	100.2	115.2	130.2	145.2	160.2	180.2	200.2	
L			2480				3322			3322		4080		mm
W			954				1104			1104		1104		mm
H			1760				1760			2160		2160		mm
A				1600						2000				mm
Operating maximum weight*	1078	1082	1102	1143	1168	1684	1765	1825	2000	2042	2094	2423	2467	kg

* Weight refers to the unit IP with tank and pumping module 2 pumps.

> RGC HE

AIR-WATER CHILLERS AND HEAT PUMPS
FOR INDOOR INSTALLATION



Efficiency capacity in heating mode - Heat pump low temperature - Medium temperature level

Acoustic setting up	40.2	50.2	60.2	70.2	80.2
AB	A+	A+	A+	A+	A+
AS	A+	A+	A+	A+	A+

NOTA: Declared according to European regulation 811/2013. The values are referred to units without options and accessories.

Available range

Unit type

IR	Chiller
IP	Heat pump (reversible on the refrigerant side)
BR	Chiller Brine
BP	Heat pump Brine (reversible on the refrigerant side)

Version

VB	Base version
VD	Desuperheater version
VR	Total recovery version

Acoustic setting up

AB	Base setting up
AS	Low noise setting up

Source temperature level

M	Medium temperature level
A	High temperature level

Unit description

This series of air-water chillers and heat pumps satisfies the cooling and heating requirements of residential plants of medium size.

All the units are suitable for indoor installation and can be applied to fan coil plants, radiant floor plants and high efficiency radiators plants.

The refrigerant circuit, contained in a compartment protected from the air flow to simplify the maintenance operations, is equipped with scroll compressors mounted on damper supports, brazed plate heat exchanger, thermostatic expansion valve (standard for IR) or electronic expansion valve (standard for IP / option for IR), re-

verse cycle valve, dehydrator filter, double inlet centrifugal fans with forward curved blades, finned coil made of copper pipes and aluminium louvered fins with sub-cooling section. The circuit is protected by a safety gas valve, high and low pressure switches and differential pressure switch on the plate heat exchanger. The plate heat exchanger and all the hydraulic pipes are thermally insulated in order to avoid condensate generation and to reduce thermal losses.

All the units can be equipped with variable speed fans control that allows the units to operate with low outdoor temperatures in cooling and high outdoor temperature in heating and permits to reduce noise emissions in such operating conditions.

The low noise acoustic setting up (AS) is obtained, starting from the base setting up (AB), mounting sound jackets on the compressors and the technical compartment is clad with soundproofing material of suitable thickness.

All the units are supplied with a management and control electrical panel containing general switch, phase presence and correct sequence controller, microprocessor controller with display and all the other electrical components with IP54 minimum protection degree.

All the units are accurately built and individually tested in the factory. Only electric and hydraulic connections are required for installation.

Options

Storing and pumping module available in the configurations :

- Storage tank arranged as buffer on the flow or as primary-secondary buffer
- 1 or 2 pumps
- standard or high head pump
- modulating pump

Expansion valve

- thermostatic
- electronic (standard for IP)

Compressor starting

- standard (contactors)
- soft starter

Fans control

- on-off control
- modulating control (condensation / evaporation control)

Compressor power factor correction

Electrical load protection

- fuses
- thermal magnetic circuit breakers

Coil condensate tray

(standard for IP)

Accessories

Rubber vibration dampers

Spring vibration dampers

Coil protection grilles

Tank antifreeze electrical heater

Remote control

Modbus serial interface on RS485

Programmer clock

Phase sequence and voltage controller

Low temperature kit (standard for IP)

High and low pressure gauges

High temperature thermostat

Outdoor air sensor

Water flow switch

Victaulic hydraulic fittings

NET NOMINAL performances - Standard plants - EUROVENT certified data

IR	Base setting up (AB)	40.2	50.2	60.2	70.2	80.2	90.2	100.2	115.2	130.2	145.2	160.2	180.2	
A35W7	Cooling capacity	47,2	55,9	63,1	70,5	83,4	94,9	106	120	133	153	173	197	kW
	Power input	14,9	17,2	19,8	22,1	27,2	31,2	34,6	38,6	42,7	50,0	55,5	64,6	kW
	EER	3,17	3,25	3,19	3,19	3,07	3,04	3,06	3,11	3,11	3,06	3,12	3,05	W/W
	SEER*	4,14	4,15	4,11	4,16	3,92	4,12	4,12	4,13	4,15	4,13	4,10	4,13	W/W
	Water flow rate	2,26	2,69	3,03	3,39	4,00	4,56	5,11	5,78	6,40	7,36	8,31	9,46	l/s
	Pressure drops	24	34	33	41	31	32	34	33	35	35	38	39	kPa
IR	Low noise setting up (AS)	40.2	50.2	60.2	70.2	80.2	90.2	100.2	115.2	130.2	145.2	160.2	180.2	
A35W7	Cooling capacity	47,2	55,9	63,1	70,5	83,4	94,9	106	120	133	153	173	197	kW
	Power input	14,9	17,2	19,8	22,1	27,2	31,2	34,6	38,6	42,7	50,0	55,5	64,6	kW
	EER	3,17	3,25	3,19	3,19	3,07	3,04	3,06	3,11	3,11	3,06	3,12	3,05	W/W
	SEER	3,96	3,99	3,95	4,02	3,86	4,01	3,90	4,00	3,97	3,93	3,98	3,95	W/W
	Water flow rate	2,26	2,69	3,03	3,39	4,00	4,56	5,11	5,78	6,40	7,36	8,31	9,46	l/s
	Pressure drops	24	34	33	41	31	32	34	33	35	35	38	39	kPa
IP	Base setting up (AB)	40.2	50.2	60.2	70.2	80.2	90.2	100.2	115.2	130.2	145.2	160.2	180.2	
A35W7	Cooling capacity	45,3	53,6	60,7	67,8	81,3	92,4	103	115	128	147	166	191	kW
	Power input	14,6	17,1	19,4	21,7	26,7	30,2	33,8	37,8	41,8	48,5	54,3	62,8	kW
	EER	3,10	3,13	3,13	3,12	3,04	3,06	3,05	3,04	3,06	3,03	3,06	3,04	W/W
	SEER	4,03	4,10	4,02	4,01	3,84	3,92	3,93	3,94	4,03	3,94	4,03	3,94	W/W
	Water flow rate	2,17	2,58	2,91	3,26	3,90	4,43	4,97	5,54	6,16	7,07	7,98	9,17	l/s
	Pressure drops	22	31	30	38	29	30	32	30	32	32	35	37	kPa
A7W45	Heating capacity	49,4	58,3	66,0	74,1	88,4	100	113	126	141	161	181	207	kW
	Power input	15,5	18,1	20,8	23,4	27,9	31,6	35,5	39,7	44,3	51,0	57,1	65,6	kW
	COP	3,19	3,22	3,17	3,17	3,17	3,16	3,18	3,17	3,18	3,16	3,17	3,16	W/W
	Water flow rate	2,35	2,77	3,13	3,52	4,20	4,77	5,35	5,97	6,69	7,64	8,60	9,84	l/s
	Pressure drops	26	36	35	44	34	35	37	35	38	38	41	42	kPa
IP	Low noise setting up (AS)	40.2	50.2	60.2	70.2	80.2	90.2	100.2	115.2	130.2	145.2	160.2	180.2	
A35W7	Cooling capacity	45,3	53,6	60,7	67,8	81,3	92,4	103	115	128	147	166	191	kW
	Power input	14,6	17,1	19,4	21,7	26,7	30,2	33,8	37,8	41,8	48,5	54,3	62,8	kW
	EER	3,10	3,13	3,13	3,12	3,04	3,06	3,05	3,04	3,06	3,03	3,06	3,04	W/W
	SEER	3,96	4,02	3,96	3,96	3,79	3,88	3,89	3,89	3,97	3,90	3,98	3,89	W/W
	Water flow rate	2,17	2,58	2,91	3,26	3,90	4,43	4,97	5,54	6,16	7,07	7,98	9,17	l/s
	Pressure drops	22	31	30	38	29	30	32	30	32	32	35	37	kPa
A7W45	Heating capacity	49,4	58,3	66,0	74,1	88,4	100	113	126	141	161	181	207	kW
	Power input	15,5	18,1	20,8	23,4	27,9	31,6	35,5	39,7	44,3	51,0	57,1	65,6	kW
	COP	3,19	3,22	3,17	3,17	3,17	3,16	3,18	3,17	3,18	3,16	3,17	3,16	W/W
	Water flow rate	2,35	2,77	3,13	3,52	4,20	4,77	5,35	5,97	6,69	7,64	8,60	9,84	l/s
	Pressure drops	26	36	35	44	34	35	37	35	38	38	41	42	kPa

The values are referred to units without options and accessories.

Data declared according to **EN 14511**:

EER (Energy Efficiency Ratio) = ratio of the total cooling capacity to the effective power input of the unit

COP (Coefficient Of Performance) = ratio of the total heating capacity to the effective power input of the unit

SEER (Seasonal Energy Efficiency Ratio) dichiarato secondo EN 14825

A35W7 = source : air in 35°C d.b. / plant : water in 12°C out 7°C

A7W45 = source : air in 7°C d.b. 6°C w.b. / plant : water in 40°C out 45°C

* Calculated value with option modulating fans regulation

Acoustic performances

Base setting up (AB)	40.2	50.2	60.2	70.2	80.2	90.2	100.2	115.2	130.2	145.2	160.2	180.2	
Sound power level ^(E)	88	88	89	89	91	91	91	96	96	97	97	98	dB(A)
Sound pressure level at 1 meter	70	70	71	71	73	73	73	78	78	79	79	80	dB(A)
Sound pressure level at 5 meters	61	61	62	62	65	65	65	69	69	70	70	71	dB(A)
Sound pressure level at 10 meters	56	56	57	57	59	59	59	64	64	65	65	66	dB(A)
Low noise setting up (AS)	40.2	50.2	60.2	70.2	80.2	90.2	100.2	115.2	130.2	145.2	160.2	180.2	
Sound power level ^(E)	85	85	86	86	88	88	88	93	93	94	94	95	dB(A)
Sound pressure level at 1 meter	67	67	68	68	70	70	70	75	75	76	76	77	dB(A)
Sound pressure level at 5 meters	58	58	59	59	62	62	62	66	66	67	67	68	dB(A)
Sound pressure level at 10 meters	53	53	54	54	56	56	56	61	61	62	62	63	dB(A)

(E): EUROVENT certified data

The acoustic performances are referred to units operating in cooling mode at nominal conditions A35W7.

Unit placed in free field on reflecting surface (directional factor equal to 2).

The sound power level is measured according to ISO 9614 standard.

The sound pressure level is calculated according to ISO 3744 and is referred to a distance of 1/5/10 metres from the external surface of the unit.

Technical data

Unit	40.2	50.2	60.2	70.2	80.2	90.2	100.2	115.2	130.2	145.2	160.2	180.2	
Power supply	400 - 3 - 50												V-ph-Hz
Compressor type	scroll												-
N° compressors / N° refrigerant circuits	2 / 1												n°
Plant side heat exchanger type	stainless steel brazed plates												-
Source side heat exchanger type	finned coil												-
Fans type	centrifugal												-
N° fans	1			2			3			4			n°
Tank volume	200				400				460				l
Hydraulic fittings	2" VICTAULIC						2" 1/2 VICTAULIC						-

Electrical data

Standard unit	40.2	50.2	60.2	70.2	80.2	90.2	100.2	115.2	130.2	145.2	160.2	180.2	
FLA - Full load current at maximum tolerated conditions	43,2	48,8	56,7	62,1	74,9	80,5	95,0	109	117	145	169	188	A
FLI - Full load power input at maximum tolerated conditions	25,2	28,0	33,0	35,6	41,9	47,3	58,3	67,3	72,8	88,7	103	113	kW
MIC - Maximum instantaneous current of the unit	137	147	152	177	218	269	264	278	278	370	394	384	A
MIC SS - Maximum instantaneous current of the unit with soft starter options	92,4	99,4	105	121	148	179	180	194	194	222	279	277	A
Unit with high head modulating pump	40.2	50.2	60.2	70.2	80.2	90.2	100.2	115.2	130.2	145.2	160.2	180.2	
FLA - Full load current at maximum tolerated conditions	49,3	54,9	62,8	68,2	81,0	86,6	101	118	126	153	179	198	A
FLI - Full load power input at maximum tolerated conditions	28,7	31,5	36,5	39,1	45,4	50,8	61,8	71,8	77,3	93,2	109	119	kW
MIC - Maximum instantaneous current of the unit	143	153	158	183	224	275	270	287	287	378	405	394	A
MIC SS - Maximum instantaneous current of the unit with soft starter options	98,5	105	111	127	155	185	186	203	203	231	290	287	A

Operative range

Temperature	Unit type	Cooling		Heating		
		min	max	min	max	
Outdoor air inlet temperature	IR, BR, IP, BP	-10*	52**	-15	40*	(°C)
Water outlet temperature	IR, IP	5	25	30	55	(°C)
Water outlet temperature	BR, BP	-12	5	30	55	(°C)
Water outlet temperature (VD)	IR, BR, IP, BP	30	70	30	70	(°C)
Water outlet temperature (VR)	IR, BR	30	55	-	-	(°C)

* with fans modulating control option (condensation / evaporation control)

** with ATC outdoor high temperature protection function

Aeraulic performance

Unit	40.2	50.2	60.2	70.2	80.2	90.2	100.2	115.2	130.2	145.2	160.2	180.2	200.2	
Available static head	150	150	150	150	150	150	150	150	150	150	150	150	150	Pa

VD and VR versions

These units allow to recover the heating power, otherwise wasted on air, through an additional heat exchanger.

The **Desuperheater Version (VD)** allow the hot water production at temperatures between 30 and 70°C through the partial heat recovery of the condensation heat.

The **Total Recovery Version (VR)** allows the cold water production and, at the same time, the hot water production at temperatures between 30 and 55°C through the total recovery of the condensation heat.

Desupeheater Version (VD) - NET NOMINAL performances

IR	Base setting up (AB)	40.2	50.2	60.2	70.2	80.2	90.2	100.2	115.2	130.2	145.2	160.2	180.2	
A35W7 - W45	Cooling capacity	49,1	58,1	65,5	73,3	86,7	98,6	110	125	138	159	180	205	kW
	Total power input	14,5	16,7	19,4	21,5	26,6	30,5	33,8	37,7	41,6	48,8	54,1	63,1	kW
	EER	3,38	3,47	3,38	3,41	3,26	3,24	3,27	3,32	3,32	3,26	3,32	3,24	W/W
	HRE	4,36	4,48	4,36	4,4	4,21	4,18	4,22	4,28	4,29	4,21	4,29	4,19	W/W
	Water flow rate	2,36	2,79	3,15	3,53	4,17	4,74	5,3	6,02	6,64	7,64	8,65	9,84	l/s
	Water pressure drop	26	37	36	44	34	35	37	36	38	38	41	42	kPa
	Heating recovery capacity	14,2	16,9	19	21,3	25,1	28,6	32,1	36,2	40,3	46,3	52,3	59,4	kW
	Water flow rate recovery	0,68	0,81	0,91	1,02	1,2	1,37	1,53	1,73	1,93	2,21	2,5	2,84	l/s
	Water pressure drop recovery	7	10	13	16	21	16	20	12	15	20	25	20	kPa
	IP	Base setting up (AB)	40.2	50.2	60.2	70.2	80.2	90.2	100.2	115.2	130.2	145.2	160.2	180.2
A35W7 - W45	Cooling capacity	47,1	55,8	63,1	70,4	84,6	96	107	120	133	153	173	199	kW
	Total power input	14,2	16,6	18,9	21,2	26	29,5	33	36,8	40,7	47,3	53,1	61,4	kW
	EER	3,32	3,36	3,33	3,33	3,25	3,25	3,25	3,27	3,27	3,24	3,26	3,24	W/W
	HRE	4,28	4,34	4,3	4,3	4,19	4,2	4,2	4,21	4,22	4,18	4,2	4,17	W/W
	Water flow rate	2,26	2,68	3,03	3,39	4,06	4,61	5,16	5,78	6,4	7,36	8,31	9,56	l/s
	Water pressure drop	24	34	33	41	32	33	35	33	35	35	38	40	kPa
	Heating recovery capacity	13,6	16,2	18,3	20,5	24,5	27,9	31,1	34,7	38,6	44,4	50,1	57,5	kW
	Water flow rate recovery	0,65	0,77	0,87	0,98	1,17	1,33	1,49	1,66	1,84	2,12	2,39	2,75	l/s
	Water pressure drop recovery	7	9	12	14	20	16	19	11	14	18	23	19	kPa

Total Recovery Version (VR) - NET NOMINAL performances

IR	Base setting up (AB)	40.2	50.2	60.2	70.2	80.2	90.2	100.2	115.2	130.2	145.2	160.2	180.2	
A35W7 - W45	Cooling capacity	49,1	58,1	65,5	73,3	86,7	98,6	110	125	138	159	180	205	kW
	Total power input	13,2	15,4	17,4	19,5	22,8	26,6	29,9	33,7	37,7	43	48,2	55,4	kW
	EER	3,72	3,76	3,77	3,75	3,81	3,72	3,7	3,71	3,66	3,7	3,73	3,7	W/W
	HRE	8,39	8,47	8,49	8,46	8,55	8,39	8,35	8,37	8,27	8,36	8,42	8,34	W/W
	Water flow rate	2,36	2,79	3,15	3,53	4,17	4,74	5,3	6,02	6,64	7,64	8,65	9,84	l/s
	Water pressure drop	26	37	36	44	34	35	37	36	38	38	41	42	kPa
	Heating recovery capacity	61,7	72,7	82,1	91,9	108	124	139	157	174	200	226	257	kW
	Water flow rate recovery	2,95	3,47	3,92	4,39	5,16	5,92	6,64	7,5	8,31	9,56	10,8	12,3	l/s
	Water pressure drop recovery	34	47	42	41	48	47	52	49	51	50	54	53	kPa

Data declared according to EN 14511. The values are referred to units without options and accessories.

EER (Energy Efficiency Ratio) = ratio of the total cooling capacity to the effective power input of the unit

HRE (Heat Recovery Efficiency) = ratio of the total capacity of the system (heating plus cooling capacity) to the effective power input

A35W7 - W45 = source : air in 35°C d.b. / plant : water in 12°C out 7°C / Recovery : water in 40°C out 45°C

CONTROL SYSTEM

The units are equipped with a controller designed to ensure energy saving and unit efficiency. Available functions :

- Adaptive function
- Dynamic defrost
- Sound management
- Climatic control in heating and in cooling mode
- Economy function
- Demand limit
- Integrative heating
- Remote stand by
- Remote cooling-heating



DIMENSIONS - MINIMUM OPERATING AREA - WEIGHT

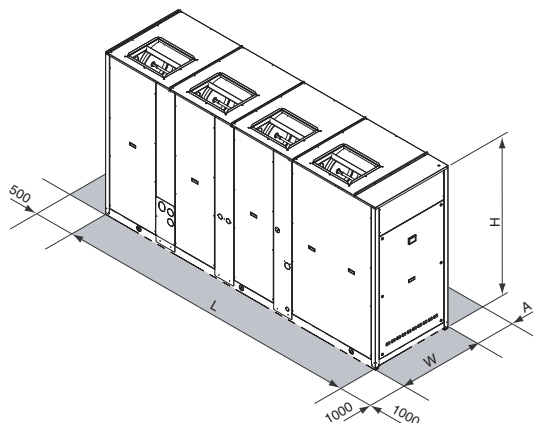

	40.2	50.2	60.2	70.2	80.2	90.2	100.2	115.2	130.2	145.2	160.2	180.2		
L		2480				3322			3322		4080			mm
W		954				1104			1104		1104			mm
H		1760				1760			2160		2160			mm
A		1600							2000					mm
Operating maximum weight*	1121	1125	1146	1189	1670	1751	1836	2051	2080	2124	2478	2520	kg	

* Weight refers to the unit IP with tank and pumping module 2 pumps.

> RGW

WATER-WATER CHILLERS AND HEAT PUMPS FOR INDOOR INSTALLATION



Unit with closing panels

Available range

Unit type

IR	Chiller
IW	Heat pump (reversible on the water side)
IP	Heat pump (reversible on the refrigerant side)
BR	Chiller Brine
BW	Heat pump Brine (reversible on the water side)
BP	Heat pump Brine (reversible on the refrigerant side)

Version

VB	Base version
----	--------------

Acoustic setting up

AB	Base setting up
AS	Low noise setting up
AX	eXtra low noise setting up

Unit description

This series of water-water chillers and heat pumps satisfies the cooling and heating requirements of commercial and industrial plants of medium size.

All the units are suitable for indoor installation and can be applied to fan coil plants, radiant floor plants and high efficiency radiators plants.

The refrigerant circuit is equipped with 2 scroll compressors, mounted on rubber vibration-damper supports, plant side heat exchanger brazed plate-type in stainless steel (AISI 316), complete with thermal insulation shell and differential pressure switch, source side exchanger brazed plate-type in stainless steel (AISI 316), complete with thermal insulation (IW, IP, BW, BP only) and differential pressure switch. (IP, BP only), thermostatic

expansion valve or electronic expansion valve (standard for IP, BP), 4-way valve, dehydrator filter, refrigerant circuit protected by refrigerant safety valve, low and high pressure switches, electrical panel for power and control complete with main breaker power supply with door lock function microprocessor controller with keyboard-display, and phase sequence controller (standard). When developing the range special attention has been paid to the choice of heat exchangers in order to obtain high efficiencies at full and partial loads to maximise the seasonal efficiency rating (ESEER) and therefore reduce consumption and running costs. The units can be chosen in Basic setting up (AB) (unit without closing panels), Low noise setting up (AS), featuring closing panels coated with acoustic material, Extra Low noise setting up (AX) featuring closing panels coated with superior acoustic material and soundproofing jackets on the compressors.

A wide range of accessories completes the commercial offer. These include pumping modules with 1 or 2 pumps available with standard or high head with a maximum of 4 pumps: 2 on plant side and 2 on source side.

The electronic controller can manage the various condensation control systems of the numerous applications required, enabling the control of 2-way or 3-way modulating valves (also offered as accessories) or the control of pumps under INVERTER. The units can therefore be combined with liquid coolers (dry-coolers), cooling towers, geothermal boreholes or use for water cooling city or well water. All the units are carefully built in compliance with the current regulations and individually tested. Installation therefore only requires the electrical and hydraulic connection.

Options

Pumping Modules

Available on various configurations:

- 1 or 2 pumps plant side
- 1 or 2 pumps source side
- pumps standard, high and extra high pressure head

Expansion valve

- thermostatic
- electronic (standard for IP, BP)

Suitable for outdoor installation

Accessories

Rubber vibration dampers

Remote controller

Serial Interface Modbus-RS 485

Programmer clock

Phase sequence and voltage controller

Low temperature kit

High and low pressure gauges

High temperature thermostat

Compressors shut-off valves

(for IR, BR, IW, BW only)

Outdoor air sensor

Water flow switch

Victaulic hydraulic fittings

Victaulic bends

Victaulic water shut-off valves

Victaulic water filter

2-way valve for cond./evap control

3-way valve for cond./evap control

Compressors start-up with soft starter

Compressors power factor correction

Electrical load protection with thermal magnetic circuit breakers

NET NOMINAL performances - Standard plants - EUROVENT certified data

IR		70.2	80.2	90.2	105.2	120.2	135.2	150.2	170.2	190.2	215.2	240.2	
W30W7	Cooling capacity	69,5	78,5	91,4	104,3	117,2	132,1	146,9	168,8	190,5	214,3	238,1	kW
	Power input	16,4	18,1	21,9	25,2	28,6	32,3	36,3	41,3	46,4	53,0	59,7	kW
	EER	4,23	4,34	4,17	4,14	4,10	4,09	4,05	4,09	4,11	4,04	3,99	W/W
	SEER	5,19	5,15	5,16	5,20	5,15	5,17	5,13	5,15	5,17	5,17	5,15	W/W
	Water flow rate plant side	3,3	3,8	4,4	5,0	5,6	6,4	7,1	8,1	9,2	10,3	11,5	l/s
	Pressure drops plant side	47	38	40	41	44	42	45	46	48	48	49	kPa
	Water flow rate source side	4,0	4,5	5,3	6,1	6,8	7,7	8,6	9,8	11,1	12,5	13,9	l/s
	Pressure drops source side	68	55	59	60	65	62	66	67	70	71	72	kPa
IW		70.2	80.2	90.2	105.2	120.2	135.2	150.2	170.2	190.2	215.2	240.2	
W30W7	Cooling capacity	69,5	78,5	91,4	104,3	117,2	132,1	146,9	168,8	190,5	214,3	238,1	kW
	Power input	16,4	18,1	21,9	25,2	28,6	32,3	36,3	41,3	46,4	53,0	59,7	kW
	EER	4,23	4,34	4,17	4,14	4,10	4,09	4,05	4,09	4,11	4,04	3,99	W/W
	SEER	5,19	5,15	5,16	5,20	5,15	5,17	5,13	5,15	5,17	5,17	5,15	W/W
	Water flow rate plant side	3,34	3,77	4,40	5,02	5,64	6,35	7,07	8,12	9,17	10,32	11,47	l/s
	Pressure drops plant side	47	38	40	41	44	42	45	46	48	48	49	kPa
	Water flow rate source side	4,03	4,54	5,32	6,07	6,83	7,71	8,58	9,84	11,09	12,52	13,94	l/s
	Pressure drops source side	68	55	59	60	65	62	66	67	70	71	72	kPa
W10W45	Heating capacity	78,7	87,6	103,8	117,9	132,1	149,2	166,5	190,7	215,0	242,3	270,6	kW
	Power input	20,6	22,5	27,1	30,9	34,8	39,2	44,1	50,2	56,5	63,8	71,4	kW
	COP	3,81	3,90	3,84	3,82	3,80	3,81	3,78	3,80	3,81	3,80	3,79	W/W
	Water flow rate plant side	3,73	4,16	4,92	5,59	6,26	7,07	7,88	9,03	10,18	11,47	12,80	l/s
	Pressure drops plant side	58	46	50	51	54	52	56	57	59	59	61	kPa
	Water flow rate source side	4,03	4,54	5,32	6,07	6,83	7,71	8,58	9,84	11,09	12,52	13,94	l/s
Pressure drops source side	68	55	59	60	65	62	66	67	70	71	72	kPa	
IP		70.2	80.2	90.2	105.2	120.2	135.2	150.2	170.2	190.2	215.2	240.2	
W30W7	Cooling capacity	68,1	77,0	89,6	102,3	114,9	129,5	144,0	165,4	186,8	210,1	233,4	kW
	Power input	16,2	17,9	21,6	24,9	28,2	31,8	35,8	40,7	45,7	52,3	58,9	kW
	EER	4,20	4,31	4,14	4,11	4,07	4,07	4,03	4,07	4,09	4,02	3,96	W/W
	SEER	5,15	5,13	5,13	5,15	5,10	5,12	5,10	5,11	5,13	5,12	5,11	W/W
	Water flow rate plant side	3,3	3,7	4,3	4,9	5,5	6,2	6,9	8,0	9,0	10,1	11,2	l/s
	Pressure drops plant side	45	36	38	39	42	40	43	44	46	46	47	kPa
	Water flow rate source side	3,95	4,45	5,22	5,96	6,71	7,57	8,43	9,66	10,89	12,29	13,69	l/s
	Pressure drops source side	66	53	56	58	62	60	64	65	68	68	70	kPa
W10W45	Heating capacity	77,7	86,6	102,8	116,8	130,8	147,7	165,4	188,8	212,8	239,8	267,9	kW
	Power input	20,7	22,5	27,1	31,0	34,9	39,3	44,2	50,3	56,4	64,0	71,6	kW
	COP	3,76	3,85	3,80	3,77	3,75	3,76	3,74	3,76	3,77	3,75	3,74	W/W
	Water flow rate plant side	3,7	4,1	4,9	5,5	6,2	7,0	7,8	8,9	10,1	11,4	12,7	l/s
	Pressure drops plant side	57	45	49	50	53	51	55	56	58	58	60	kPa
	Water flow rate source side	3,95	4,45	5,22	5,96	6,71	7,57	8,43	9,66	10,89	12,29	13,69	l/s
Pressure drops source side	66	53	56	58	62	60	64	65	68	68	70	kPa	

Data declared according to **EN 14511**. The values are referred to units without options and accessories.
EER (Energy Efficiency Ratio) = ratio of the total cooling capacity to the effective power input of the unit
COP (Coefficient Of Performance) = ratio of the total heating capacity to the effective power input of the unit

SEER (Seasonal Energy Efficiency Ratio) dichiarato secondo EN 14825
W30W7 = source : water in 30°C out 35°C / plant : water in 12°C out 7°C
W10W45 = source : water in 10°C / plant : water in 40°C out 45°C

Acoustic performances

Base setting up (AB)	70.2	80.2	90.2	105.2	120.2	135.2	150.2	170.2	190.2	215.2	240.2	
Sound power level ^(E)	75	76	77	77	77	78	78	79	79	80	80	dB(A)
Sound pressure level at 1 meter	59	60	61	61	61	62	62	63	63	64	64	dB(A)
Sound pressure level at 5 meters	49	50	51	51	51	52	52	53	53	54	54	dB(A)
Sound pressure level at 10 meters	44	45	46	46	46	47	47	48	48	49	49	dB(A)
Low noise setting up (AS)	70.2	80.2	90.2	105.2	120.2	135.2	150.2	170.2	190.2	215.2	240.2	
Sound power level ^(E)	71	72	73	73	73	74	74	75	75	76	76	dB(A)
Sound pressure level at 1 meter	55	56	57	57	57	58	58	59	59	60	60	dB(A)
Sound pressure level at 5 meters	45	46	47	47	47	48	48	49	49	50	50	dB(A)
Sound pressure level at 10 meters	40	41	42	42	42	43	43	44	44	45	45	dB(A)
eXtra low noise setting up (AX)	70.2	80.2	90.2	105.2	120.2	135.2	150.2	170.2	190.2	215.2	240.2	
Sound power level ^(E)	67	68	69	69	69	70	70	71	71	72	72	dB(A)
Sound pressure level at 1 meter	51	52	53	53	53	54	54	55	55	56	56	dB(A)
Sound pressure level at 5 meters	41	42	43	43	43	44	44	45	45	46	46	dB(A)
Sound pressure level at 10 meters	36	37	38	38	38	39	39	40	40	41	41	dB(A)

(E): EUROVENT certified data

The acoustic performances are referred to units operating in cooling mode at nominal conditions W30/W7.

Unit placed in free field on reflecting surface (directional factor equal to 2).

The sound power level is measured according to ISO 9614 standard.

The sound pressure level is calculated according to ISO 3744 and is referred to a distance of 1/5/10 metres from the external surface of the unit.

Technical data

Unit	70.2	80.2	90.2	105.2	120.2	135.2	150.2	170.2	190.2	215.2	240.2	
Power supply	400 - 3 - 50											V-ph-Hz
Compressor type	scroll											-
N° compressors / N° refrigerant circuits	2 / 1											n°
Plant side heat exchanger type	stainless steel brazed plates											-
Source side heat exchanger type	stainless steel brazed plates											-
IN/OUT Plant side hydraulic fittings	2" 1/2 VICTAULIC											"
IN/OUT Source side hydraulic fittings	2" 1/2 VICTAULIC											"

Electrical data

Standard unit	70.2	80.2	90.2	105.2	120.2	135.2	150.2	170.2	190.2	215.2	240.2	
FLA - Full load current at maximum tolerated conditions	45	51	62	68	74	82	90	105	120	142	164	A
FLI - Full load power input at maximum tolerated conditions	26	29	34	40	45	50	55	63	72	83	93	kW
MIC - Maximum instantaneous current of the unit	141	166	204	256	262	309	317	355	370	454	476	A
MIC SS - Maximum instantaneous current of the unit with soft starter options	93	110	135	166	172	200	208	231	246	296	318	A
Unit with high head modulating pump	70.2	80.2	90.2	105.2	120.2	135.2	150.2	170.2	190.2	215.2	240.2	
FLA - Full load current at maximum tolerated conditions	60	66	77	83	89	103	111	129	144	169	191	A
FLI - Full load power input at maximum tolerated conditions	35	38	42	48	54	62	67	77	86	98	109	kW
MIC - Maximum instantaneous current of the unit	155	180	219	271	277	330	338	379	394	481	503	A
MIC SS - Maximum instantaneous current of the unit with soft starter options	108	124	149	181	187	221	229	255	270	323	345	A

Operating range

Temperature	Unit type	Cooling		Heating		
		min	max	min	max	
Water inlet temperature source side	IR, IW, IP, BR, BP	20 (5*)	50	10	25 (40*)	(°C)
Water outlet temperature plant side	IR, IW, IP	5	20	25	55	(°C)
Water outlet temperature plant side	BR, BP	-12	5	25	55	(°C)

* with condensation / evaporation control devices

CONTROL SYSTEM

The units are equipped with a controller designed to ensure energy saving and unit efficiency. Available functions :

- Adaptive function
- Climatic control in heating and in cooling mode
- Economy function
- Demand limit
- Integrative heating
- Condensation / evaporation control
- Remote stand by
- Remote cooling-heating



DIMENSIONS - MINIMUM OPERATING AREA - WEIGHT

(reference drawing: unit with closing panel)

STANDARD UNIT

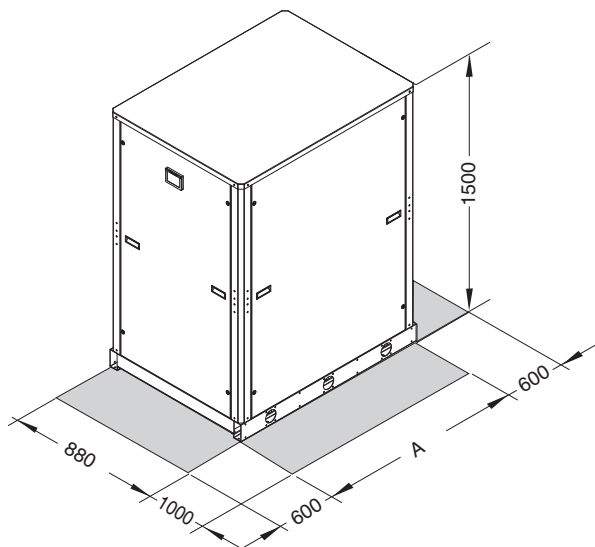

		70.2	80.2	90.2	105.2	120.2	135.2	150.2	170.2	190.2	215.2	240.2	
STANDARD UNIT	A	880			1175								mm
	Operating maximum weight	404	416	427	548	635	668	696	741	771	812	844	kg

STANDARD UNIT+ PUMPING MODULE MP

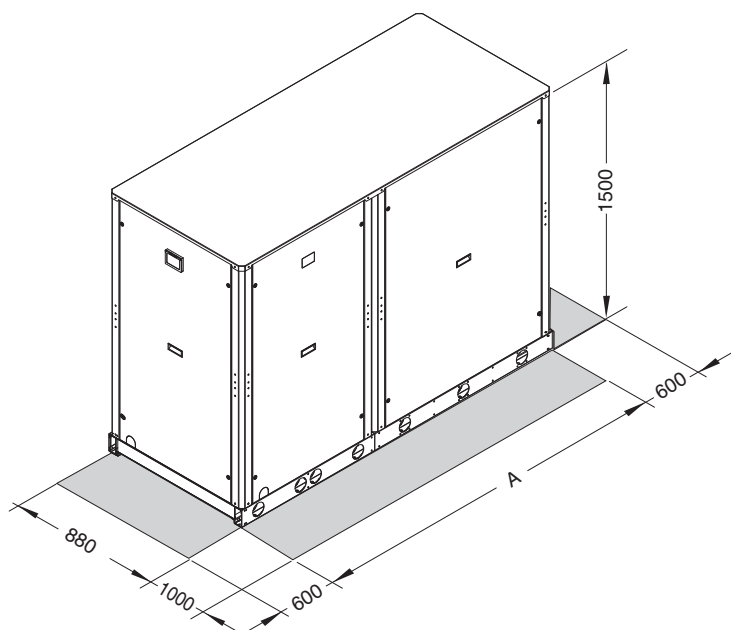

		70.2	80.2	90.2	105.2	120.2	135.2	150.2	170.2	190.2	215.2	240.2	
STANDARD UNIT+ PUMPING MODULE MP	A (2+2 extra high head pumps)	2055			2350								mm
	Operating maximum weight (2+2 extra high head pumps)	809	817	828	1059	1146	1225	1253	1321	1351	1415	1447	kg

> CMA² - CMA² HE

CONDENSING UNITS
FOR OUTDOOR INSTALLATION



Available range

Unit type

- SR Condensing unit
- SP Reversible condensing unit (reversible on the refrigerant side)

Versions

- VB Base Version

Acoustic setting up

- AB Base setting up
- AS Low noise setting up

Unit description

This series of condensing units satisfies the cooling and heating requirements of residential plants of small and medium size.

All the units are suitable for outdoor installation and can be connected to a remote heat exchanger properly designed in order to transfer to the plant all the cooling (and heating for reversible units) power generated.

It is possible for example to connect direct expansion coils placed inside air handling units or remote plate heat exchangers placed inside technical rooms. In both cases the lack of outdoor hydraulic pipes eliminates the freezing problems and avoids brine solutions to be used.

The refrigerant circuit, contained in a compartment protected from the air flow to simplify the maintenance operations, is

equipped with scroll compressor mounted on damper supports, axial fans with safety protection grilles, finned coil made of copper pipes and aluminium louvered fins and shut off valves on the liquid line and on the gas line. The reversible units are moreover supplied with reverse cycle valve, thermostatic expansion valve (working in heating mode) and liquid receiver.

The circuit is protected by high and low pressure switches.

All the units can be equipped with variable speed fans control that allows the units to operate with low outdoor temperatures in cooling and high outdoor temperature in heating and permits to reduce noise emissions in such operating conditions.

The low noise acoustic setting up (AS) is obtained, starting from the base setting up (AB), reducing the rotational speed of the fans and mounting sound jackets on the compressors.

All the units are supplied with an outdoor temperature sensor, already installed on the unit, in order to realize the climatic control.

All the units are provided with a phase presence and correct sequence controller device.

All the units are accurately built and individually tested in the factory.

All the units are supplied with refrigerant charge inside.

Only electric and refrigerant connections (between condensing unit and remote heat exchanger) are required for installation.

Options

Compressor starting

- standard (contactors)
- soft starter

Fans control

- on-off control
- modulating control (condensation / evaporation control)

Electrical loads protection

- fuses
- thermal magnetic circuit breakers

Compressor power factor correction

Accessories

Rubber vibration dampers

Coil protection grille

Remote control

Modbus serial interface on RS485

Programmer clock

Phase sequence and voltage controller

Remote plate heat exchanger

Liquid line

NET NOMINAL performances - CMA²

SR	Base setting up (AB)	19.1	22.1	26.1	30.1	35.1	40.1	
A35E5	Cooling capacity	21,4	24,2	28,0	32,9	37,7	43,8	kW
	Power input	6,75	7,53	8,67	10,66	11,99	13,85	kW
	EER	3,17	3,21	3,23	3,08	3,14	3,17	W/W
SR	Low noise setting up (AS)	19.1	22.1	26.1	30.1	35.1	40.1	
A35E5	Cooling capacity	20,5	23,2	26,9	31,6	36,2	42,1	kW
	Power input	7,26	8,14	9,34	11,45	12,97	14,92	kW
	EER	2,83	2,85	2,88	2,76	2,79	2,82	W/W
SP	Base setting up (AB)	19.1	22.1	26.1	30.1	35.1	40.1	
A35E5	Cooling capacity	20,9	23,5	27,2	32,0	36,7	42,8	kW
	Power input	6,82	7,65	8,76	10,78	12,12	14,00	kW
	EER	3,06	3,07	3,11	2,97	3,02	3,06	W/W
A7C50	Heating capacity	20,0	22,5	26,1	30,9	35,5	40,1	kW
	Power input	6,87	7,71	8,95	11,07	12,42	13,97	kW
	COP	2,91	2,92	2,92	2,79	2,86	2,87	W/W
A7C45	Heating capacity	22,0	24,8	28,8	34,1	39,1	44,2	kW
	Power input	6,05	6,79	7,88	9,76	10,88	12,25	kW
	COP	3,64	3,66	3,66	3,50	3,60	3,61	W/W
SP	Low noise setting up (AS)	19.1	22.1	26.1	30.1	35.1	40.1	
A35E5	Cooling capacity	20,0	22,6	26,2	30,7	35,2	41,0	kW
	Power input	7,32	8,23	9,41	11,54	13,09	15,05	kW
	EER	2,73	2,74	2,79	2,66	2,69	2,72	W/W
A7C50	Heating capacity	18,9	21,4	24,9	29,6	33,8	38,2	kW
	Power input	6,63	7,41	8,61	10,66	12,02	13,40	kW
	COP	2,85	2,89	2,89	2,77	2,81	2,85	W/W
A7C45	Heating capacity	20,9	23,6	27,5	32,6	37,3	42,2	kW
	Power input	5,84	6,52	7,59	9,39	10,58	11,88	kW
	COP	3,58	3,62	3,62	3,47	3,52	3,55	W/W

NET NOMINAL performances - CMA² HE

SR	Base setting up (AB)	19.1	22.1	26.1	30.1	35.1	40.1	
A35E5	Cooling capacity	22,3	24,9	29,0	34,9	39,6	46,2	kW
	Power input	6,12	6,83	7,83	9,52	10,84	12,46	kW
	EER	3,63	3,65	3,70	3,66	3,65	3,71	W/W
SR	Low noise setting up (AS)	19.1	22.1	26.1	30.1	35.1	40.1	
A35E5	Cooling capacity	21,4	23,9	27,9	33,6	38,1	44,6	kW
	Power input	6,62	7,38	8,47	10,29	11,61	13,21	kW
	EER	3,24	3,23	3,29	3,26	3,29	3,38	W/W
SP	Base setting up (AB)	19.1	22.1	26.1	30.1	35.1	40.1	
A35E5	Cooling capacity	21,8	23,8	27,8	33,6	39	44,1	kW
	Power input	6,07	7,03	8,16	10,1	11,7	13,2	kW
	EER	3,60	3,39	3,4	3,34	3,33	3,33	W/W
A7C50	Heating capacity	20,5	23,2	27,0	31,8	36,5	42,4	kW
	Power input	6,46	7,13	8,21	10,01	11,40	12,91	kW
	COP	3,18	3,26	3,29	3,17	3,20	3,29	W/W
A7C45	Heating capacity	22,7	25,6	29,8	35,1	40,2	46,8	kW
	Power input	5,69	6,28	7,23	8,78	10,04	11,44	kW
	COP	3,98	4,08	4,12	3,99	4,01	4,09	W/W
SP	Low noise setting up (AS)	19.1	22.1	26.1	30.1	35.1	40.1	
A35E5	Cooling capacity	20,9	23,8	27,8	33,6	39	44,1	kW
	Power input	6,55	7,03	8,16	10,1	11,7	13,2	kW
	EER	3,20	3,39	3,4	3,34	3,33	3,33	W/W
A7C50	Heating capacity	19,5	22,1	25,9	30,4	34,6	40,4	kW
	Power input	6,24	6,91	7,95	9,64	10,98	12,51	kW
	COP	3,12	3,19	3,25	3,15	3,16	3,23	W/W
A7C45	Heating capacity	21,5	24,3	28,5	33,6	38,3	44,6	kW
	Power input	5,50	6,09	7,00	8,50	9,71	11,03	kW
	COP	3,91	3,99	4,08	3,96	3,95	4,05	W/W

The values are referred to units without options and accessories.

EER (Energy Efficiency Ratio) = ratio of the total cooling capacity to the effective power input of the unit
COP (Coefficient Of Performance) = ratio of the total heating capacity to the effective power input of the unit
A35E5 = source : air in 35°C d.b. / plant : evaporation temperature (dew point) 5°C - superheating 5°C
A7C50 = source : air in 7°C d.b. 6°C w.b. / plant : condensation temperature (dew point) 50°C - subcooling 5°C
A7C45 = source : air in 7°C d.b. 6°C w.b. / plant : condensation temperature (dew point) 45°C - subcooling 5°C

Acoustic performances

Base setting up (AB)	19.1	22.1	26.1	30.1	35.1	40.1	
Sound power level	77	77	78	81	82	82	dB(A)
Sound pressure level at 1 meter	61	62	62	65	66	66	dB(A)
Sound pressure level at 5 meters	51	51	52	55	55	56	dB(A)
Sound pressure level at 10 meters	46	46	47	50	50	50	dB(A)
Low noise setting up (AS)	19.1	22.1	26.1	30.1	35.1	40.1	
Sound power level	74	74	75	78	79	79	dB(A)
Sound pressure level at 1 meter	58	59	59	62	63	63	dB(A)
Sound pressure level at 5 meters	48	48	49	52	53	53	dB(A)
Sound pressure level at 10 meters	43	43	44	47	48	48	dB(A)

The acoustic performances are referred to units operating in cooling mode at nominal conditions A35E5.

Unit placed in free field on reflecting surface (directional factor equal to 2).

The sound power level is measured according to ISO 9614 standard.

The sound pressure level is calculated according to ISO 3744 and is referred to a distance of 1/5/10 metres from the external surface of the unit.

Technical data

Unit	19.1	22.1	26.1	30.1	35.1	40.1	
Power supply	400 - 3N - 50						V-ph-Hz
Compressor type	scroll						-
N° compressors / N° refrigerant circuits	1 / 1						n°
Source side heat exchanger type	finned coil						-
Fans type	axial						-
N° fans	1						n°
Tank volume	5/8"						-
Hydraulic fittings	1" 1/8						-

Electrical data

Standard unit	19.1	22.1	26.1	30.1	35.1	40.1	
FLA - Full load current at maximum tolerated conditions	18,8	20,8	22,9	25,9	29,9	34,0	A
FLI - Full load power input at maximum tolerated conditions	10,8	12,1	13,4	15,8	18,4	21,0	kW
MIC - Maximum instantaneous current of the unit	98	114	121	129	144	178	A
MIC SS - Maximum instantaneous current of the unit with soft starter options	55	64	68	73	82	102	A

Operating range

Temperature	Unit type	Cooling		Heating		°C
		min	max	min	max	
Outdoor air inlet temperature	SR, SP	-10*	48 (STD) 50 (HE)	-15	42	°C
Evaporating temperature (dew point)	SR, SP	0	15	-	-	°C
Condensing temperature (dew point)	SP	-	-	30	60	°C

* with fans modulating control option (condensation / evaporation control)

CONTROL SYSTEM

The unit is managed by a microprocessor controller to which, through a wiring board, all the electrical loads and the control devices are connected. The user interface is realized by a display and four buttons that allow to view and, if necessary, modify all the operating parameters of the unit. It's available, as an accessory, a remote control that reports all the functionalities of the user interface placed on the unit.

The main functions available are :

- water or air temperature management (through set point adjustment)
- adaptive function
- climatic control in heating and in cooling mode (automatic set point adjustment according to outdoor air temperature)
- dynamic defrost cycle management according to outdoor air temperature
- alarm memory management and diagnostic

- fans management by means of continuous rotational speed control
- pump or fan management on the plant side
- integrative electrical heaters management in heating mode (2 step logic)
- compressor and pump or fan operating hours recording
- serial communication through Modbus protocol
- remote stand by
- remote cooling-heating
- general alarm digital output



DIMENSIONS AND MINIMUM OPERATING AREA

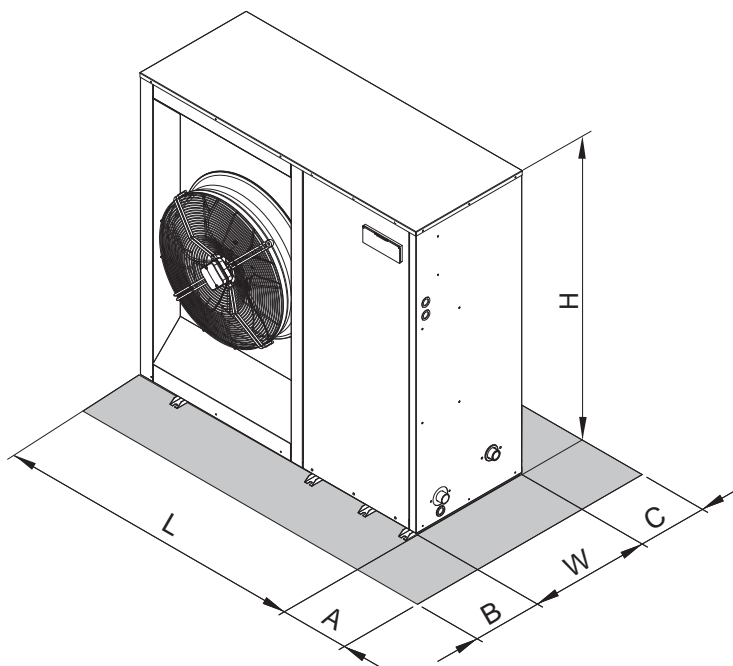

	19.1	22.1	26.1	30.1	35.1	40.1	
L	1494	1494	1494	1704	1704	1704	mm
W	576	576	576	576	576	576	mm
H	1453	1453	1453	1453	1453	1453	mm
A	400	400	400	400	400	400	mm
B	600	600	600	600	600	600	mm
C	200	200	200	200	200	200	mm
CMA unit - maximum weight operation	221	224	239	257	277	279	kg
CMA HE unit - maximum weight operation	236	239	259	279	302	304	kg

> CMP² - CMP² HE

CONDENSING UNITS
FOR INDOOR INSTALLATION



Available range

Unit type

- SR Condensing unit
- SP Reversible condensing unit (reversible on the refrigerant side)

Versions

- VB Base Version

Acoustic setting up

- AB Base setting up
- AS Low noise setting up

Unit description

This series of condensing units satisfies the cooling and heating requirements of residential plants of small and medium size.

All the units are suitable for indoor installation and can be connected to a remote heat exchanger properly designed in order to transfer to the plant all the cooling (and heating for reversible units) power generated.

It is possible for example to connect direct expansion coils placed inside air handling units or remote plate heat exchangers placed inside technical rooms. In both cases the lack of outdoor hydraulic pipes eliminates the freezing problems and avoids brine solutions to be used.

The refrigerant circuit, contained in a compartment protected from the air flow to simplify the maintenance operations, is

equipped with scroll compressor mounted on damper supports, centrifugal fans (plug fan), finned coil made of copper pipes and aluminium louvered fins and shut off valves on the liquid line and on the gas line. The reversible units are moreover supplied with reverse cycle valve, thermostatic expansion valve (working in heating mode) and liquid receiver.

The circuit is protected by high and low pressure switches.

All the units are equipped with variable speed fans control that allows the units to operate with low outdoor temperatures in cooling and high outdoor temperature in heating and permits to reduce noise emissions in such operating conditions.

The low noise acoustic setting up (AS) is obtained, starting from the base setting up (AB), reducing the rotational speed of the fans and mounting sound jackets on the compressors.

All the units are supplied with an outdoor temperature sensor, already installed on the unit, in order to realize the climatic control.

All the units are provided with a phase presence and correct sequence controller device.

All the units are accurately built and individually tested in the factory.

All the units are supplied with refrigerant charge inside.

Only electric and refrigerant connections (between condensing unit and remote heat exchanger) are required for installation.

Options

Compressor starting

- standard (contactors)
- soft starter

Electrical loads protection

- fuses
- thermal magnetic circuit breakers

Compressor power factor correction

Accessories

Rubber vibration dampers

Coil protection grille

Remote control

Modbus serial interface on RS485

Programmer clock

Phase sequence and voltage controller

Remote plate heat exchanger

Liquid line

NET NOMINAL performances - CMP²

SR	Base setting up (AB)	19.1	22.1	26.1	30.1	35.1	40.1	
A35E5	Cooling capacity	21,4	24,2	28,0	32,9	37,7	43,8	kW
	Power input	6,75	7,53	8,67	10,66	11,99	13,85	kW
	EER	3,17	3,21	3,23	3,08	3,14	3,17	W/W
SR	Low noise setting up (AS)	19.1	22.1	26.1	30.1	35.1	40.1	
A35E5	Cooling capacity	20,5	23,2	26,9	31,6	36,2	42,1	kW
	Power input	7,26	8,14	9,34	11,45	12,97	14,92	kW
	EER	2,83	2,85	2,88	2,76	2,79	2,82	W/W
SP	Base setting up (AB)	19.1	22.1	26.1	30.1	35.1	40.1	
A35E5	Cooling capacity	20,9	23,5	27,2	32,0	36,7	42,8	kW
	Power input	6,82	7,65	8,76	10,78	12,12	14,00	kW
	EER	3,06	3,07	3,11	2,97	3,02	3,06	W/W
A7C50	Heating capacity	20,0	22,5	26,1	30,9	35,5	40,1	kW
	Power input	6,87	7,71	8,95	11,07	12,42	13,97	kW
	COP	2,91	2,92	2,92	2,79	2,86	2,87	W/W
A7C45	Heating capacity	22,0	24,8	28,8	34,1	39,1	44,2	kW
	Power input	6,05	6,79	7,88	9,76	10,88	12,25	kW
	COP	3,64	3,66	3,66	3,50	3,60	3,61	W/W
SP	Low noise setting up (AS)	19.1	22.1	26.1	30.1	35.1	40.1	
A35E5	Cooling capacity	20,0	22,6	26,2	30,7	35,2	41,0	kW
	Power input	7,32	8,23	9,41	11,54	13,09	15,05	kW
	EER	2,73	2,74	2,79	2,66	2,69	2,72	W/W
A7C50	Heating capacity	18,9	21,4	24,9	29,6	33,8	38,2	kW
	Power input	6,63	7,41	8,61	10,66	12,02	13,40	kW
	COP	2,85	2,89	2,89	2,77	2,81	2,85	W/W
A7C45	Heating capacity	20,9	23,6	27,5	32,6	37,3	42,2	kW
	Power input	5,84	6,52	7,59	9,39	10,58	11,88	kW
	COP	3,58	3,62	3,62	3,47	3,52	3,55	W/W

NET NOMINAL performances - CMP² HE

SR	Base setting up (AB)	19.1	22.1	26.1	30.1	35.1	40.1	
A35E5	Cooling capacity	22,3	24,9	29,0	34,9	39,6	46,2	kW
	Power input	6,12	6,83	7,83	9,52	10,84	12,46	kW
	EER	3,63	3,65	3,70	3,66	3,65	3,71	W/W
SR	Low noise setting up (AS)	19.1	22.1	26.1	30.1	35.1	40.1	
A35E5	Cooling capacity	21,4	23,9	27,9	33,6	38,1	44,6	kW
	Power input	6,62	7,38	8,47	10,29	11,61	13,21	kW
	EER	3,24	3,23	3,29	3,26	3,29	3,38	W/W
SP	Base setting up (AB)	19.1	22.1	26.1	30.1	35.1	40.1	
A35E5	Cooling capacity	21,8	23,8	27,8	33,6	39	44,1	kW
	Power input	6,07	7,03	8,16	10,1	11,7	13,2	kW
	EER	3,60	3,39	3,4	3,34	3,33	3,33	W/W
A7C50	Heating capacity	20,5	23,2	27,0	31,8	36,5	42,4	kW
	Power input	6,46	7,13	8,21	10,01	11,40	12,91	kW
	COP	3,18	3,26	3,29	3,17	3,20	3,29	W/W
A7C45	Heating capacity	22,7	25,6	29,8	35,1	40,2	46,8	kW
	Power input	5,69	6,28	7,23	8,78	10,04	11,44	kW
	COP	3,98	4,08	4,12	3,99	4,01	4,09	W/W
SP	Low noise setting up (AS)	19.1	22.1	26.1	30.1	35.1	40.1	
A35E5	Cooling capacity	20,9	23,8	27,8	33,6	39	44,1	kW
	Power input	6,55	7,03	8,16	10,1	11,7	13,2	kW
	EER	3,20	3,39	3,4	3,34	3,33	3,33	W/W
A7C50	Heating capacity	19,5	22,1	25,9	30,4	34,6	40,4	kW
	Power input	6,24	6,91	7,95	9,64	10,98	12,51	kW
	COP	3,12	3,19	3,25	3,15	3,16	3,23	W/W
A7C45	Heating capacity	21,5	24,3	28,5	33,6	38,3	44,6	kW
	Power input	5,50	6,09	7,00	8,50	9,71	11,03	kW
	COP	3,91	3,99	4,08	3,96	3,95	4,05	W/W

The values are referred to units without options and accessories.

EER (Energy Efficiency Ratio) = ratio of the total cooling capacity to the effective power input of the unit

COP (Coefficient Of Performance) = ratio of the total heating capacity to the effective power input of the unit

A35E5 = source : air in 35°C d.b. / plant : evaporation temperature (dew point) 5°C - superheating 5°C

A7C50 = source : air in 7°C d.b. 6°C w.b. / plant : condensation temperature (dew point) 50°C - subcooling 5°C

A7C45 = source : air in 7°C d.b. 6°C w.b. / plant : condensation temperature (dew point) 45°C - subcooling 5°C

Acoustic performances

Base setting up (AB)	19.1	22.1	26.1	30.1	35.1	40.1	
Sound power level	76	76	77	80	81	81	dB(A)
Sound pressure level at 1 meter	60	60	61	64	65	65	dB(A)
Sound pressure level at 5 meters	50	50	51	54	55	55	dB(A)
Sound pressure level at 10 meters	45	45	46	49	49	50	dB(A)
Low noise setting up (AS)	19.1	22.1	26.1	30.1	35.1	40.1	
Sound power level	74	74	75	78	79	79	dB(A)
Sound pressure level at 1 meter	58	58	59	62	63	63	dB(A)
Sound pressure level at 5 meters	48	48	49	52	53	53	dB(A)
Sound pressure level at 10 meters	43	43	44	47	47	48	dB(A)

The acoustic performances are referred to units operating in cooling mode at nominal conditions A35E5.

Unit placed in free field on reflecting surface (directional factor equal to 2).

The sound power level is measured according to ISO 9614 standard.

The sound pressure level is calculated according to ISO 3744 and is referred to a distance of 1/5/10 metres from the external surface of the unit.

Technical data

Unit	19.1	22.1	26.1	30.1	35.1	40.1	
Power supply	400 - 3N - 50						V-ph-Hz
Compressor type	scroll						-
N° compressors / N° refrigerant circuits	1 / 1						n°
Source side heat exchanger type	finned coil						-
Fans type	centrifugal (plug fan)						-
N° fans	1						n°
Tank volume	5/8"						-
Hydraulic fittings	1" 1/8						-

Electrical data

Standard unit	19.1	22.1	26.1	30.1	35.1	40.1	
FLA - Full load current at maximum tolerated conditions	28,9	30,9	33,0	28,0	32,0	36,1	A
FLI - Full load power input at maximum tolerated conditions	13,0	14,3	15,6	16,8	19,4	22,0	kW
MIC - Maximum instantaneous current of the unit	108	124	131	131	146	180	A
MIC SS - Maximum instantaneous current of the unit with soft starter options	65	74	78	75	84	104	A

Operating range

Temperature	Unit type	Cooling		Heating		
		min	max	min	max	
Outdoor air inlet temperature	SR, SP	-10	48 (STD) 50 (HE)	-15	42	°C
Evaporating temperature (dew point)	SR, SP	0	15	-	-	°C
Condensing temperature (dew point)	SP	-	-	30	60	°C

CONTROL SYSTEM

The unit is managed by a microprocessor controller to which, through a wiring board, all the electrical loads and the control devices are connected. The user interface is realized by a display and four buttons that allow to view and, if necessary, modify all the operating parameters of the unit. It's available, as an accessory, a remote control that reports all the functionalities of the user interface placed on the unit.

The main functions available are :

- water or air temperature management (through set point adjustment)
- adaptive function
- climatic control in heating and in cooling mode (automatic set point adjustment according to outdoor air temperature)
- dynamic defrost cycle management according to outdoor air temperature
- alarm memory management and diagnostic

- fans management by means of continuous rotational speed control
- pump or fan management on the plant side
- integrative electrical heaters management in heating mode (2 step logic)
- compressor and pump or fan operating hours recording
- serial communication through Modbus protocol
- remote stand by
- remote cooling-heating
- general alarm digital output



DIMENSIONS AND MINIMUM OPERATING AREA

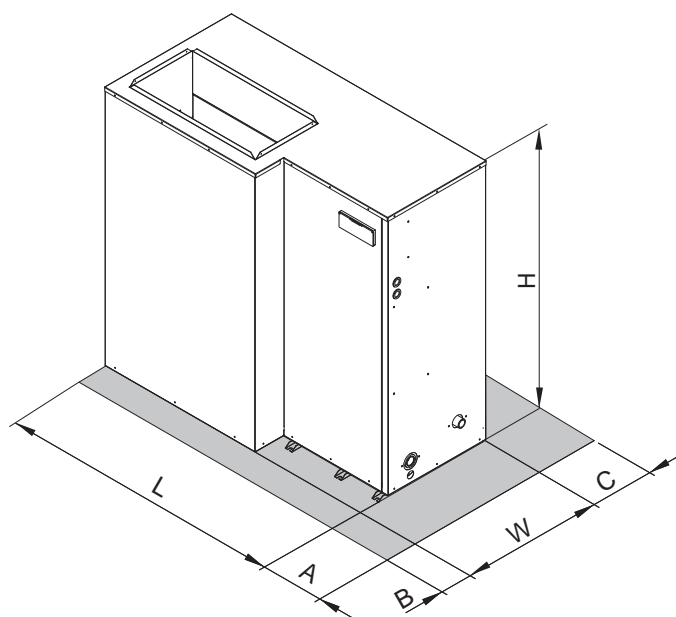

	19.1	22.1	26.1	30.1	35.1	40.1	
L	1494	1494	1494	1704	1704	1704	mm
W	744	744	744	744	744	744	mm
H	1453	1453	1453	1453	1453	1453	mm
A	400	400	400	400	400	400	mm
B	450	450	450	450	450	450	mm
C	200	200	200	200	200	200	mm
CMP unit - maximum weight operation	256	259	274	278	298	300	kg
CMP HE unit - maximum weight operation	271	274	294	303	323	325	kg

> CGA

CONDENSING UNITS FOR OUTDOOR INSTALLATION



Available range

Unit type

- SR Condensing unit
- SP Heat pump condensing unit (reversible on the refrigerant side)

Version

- VB Base version
- VD Desuperheater version
- VR Total recovery version

Acoustic setting up

- AB Base setting up
- AS Low noise setting up
- AX eXtra low noise setting up

Source temperature level

- M Medium temperature level
- A High temperature level

Unit description

This series of condensing units satisfies the cooling and heating requirements of residential plants of medium size.

All the units are suitable for outdoor installation and can be connected to a remote heat exchanger properly designed in order to transfer to the plant all the cooling (and heating for reversible units) power generated.

The refrigerant circuit, contained in a compartment protected from the air flow to simplify the maintenance operations, is equipped with scroll compressors mounted on damper supports, thermostatic expansion valve (only for SP), reverse cycle valve, axial fans with safety protec-

tion grilles, finned coil made of copper pipes and aluminium louvered fins with sub-cooling section. The circuit is protected by a safety gas valve, high and low pressure switches.

All the units can be equipped with variable speed fans control that allows the units to operate with low outdoor temperatures in cooling and high outdoor temperature in heating and permits to reduce noise emissions in such operating conditions.

The low noise acoustic setting up (AS) is obtained, starting from the base setting up (AB), reducing the rotational speed of the fans and mounting sound jackets on the compressors and the technical compartment is clad with soundproofing material of suitable thickness.

The eXtra low noise acoustic setting up (AX) is obtained, starting from the low noise setting up (AS), further reducing the rotational speed of the fans and using finned coil with bigger surface.

All the units are supplied with a management and control electrical panel containing general switch, phase presence and correct sequence controller, microprocessor controller with display and all the other electrical components with IP54 minimum protection degree.

All the units are accurately built and individually tested in the factory.

All the units are supplied with refrigerant charge inside.

Only electric and refrigerant connections (between condensing unit and remote heat exchanger) are required for installation.

Options

Compressor starting

- standard (contactors)
- soft starter

Fans control

- on-off control
- modulating control (condensation / evaporation control)

Compressor power factor correction

Electrical load protection

- fuses
- thermal magnetic circuit breakers

Coil condensate tray

Accessories

Rubber vibration dampers

Spring vibration dampers

Coil protection grilles

Remote control

Modbus serial interface on RS485

Programmer clock

Phase sequence and voltage controller

Low temperature kit (standard for SP)

High and low pressure gauges

High temperature thermostat

Coil shut off valves

Outdoor air sensor

Remote plate heat exchanger

Liquid line

NOMINAL performances

SR	Base setting up (AB)	40.2	50.2	60.2	70.2	80.2	90.2	100.2	115.2	130.2	145.2	160.2	180.2	200.2	
A35E5	Cooling capacity	48,9	57,8	63,3	74,3	85,0	98,3	110	121	136	154	171	194	216	kW
	Power input	15,5	18,4	20,5	23,7	27,6	32,1	35,5	39,4	44,5	50,8	56,3	63,7	70,6	kW
	EER	3,15	3,14	3,09	3,14	3,08	3,06	3,10	3,07	3,06	3,03	3,04	3,05	3,06	W/W
SR	Low noise setting up (AS)	40.2	50.2	60.2	70.2	80.2	90.2	100.2	115.2	130.2	145.2	160.2	180.2	200.2	
A35E5	Cooling capacity	47,4	56,1	61,3	72,0	82,4	95,3	106	118	132	150	165	189	210	kW
	Power input	16,1	19,2	21,3	24,6	28,8	33,4	36,9	41,0	46,3	52,8	58,6	66,2	73,4	kW
	EER	2,94	2,92	2,88	2,93	2,86	2,85	2,87	2,88	2,85	2,84	2,82	2,85	2,86	W/W
SR	eXtra low noise setting up (AX)	40.2	50.2	60.2	70.2	80.2	90.2	100.2	115.2	130.2	145.2	160.2	180.2	200.2	
A35E5	Cooling capacity	46,3	54,8	59,9	70,4	80,5	93,1	104	114	129	146	162	184	204	kW
	Power input	16,2	19,6	21,9	25,1	29,6	32,5	38,0	42,2	47,7	53,8	59,8	68,1	75,5	kW
	EER	2,86	2,80	2,74	2,80	2,72	2,86	2,74	2,70	2,70	2,71	2,71	2,70	2,70	W/W
SP	Base setting up (AB)	40.2	50.2	60.2	70.2	80.2	90.2	100.2	115.2	130.2	145.2	160.2	180.2	200.2	
A35E5	Cooling capacity	47,3	57,1	62,1	72,6	80,0	96,3	107	119	132	149	166	192	214	kW
	Power input	15,3	18,6	20,4	23,8	26,7	31,9	35,3	39,3	43,9	49,7	55,6	62,7	70,3	kW
	EER	3,09	3,07	3,04	3,05	3,00	3,02	3,03	3,03	3,01	3,00	2,99	3,06	3,04	W/W
A7C50	Heating capacity	47,8	57,5	62,6	73,8	82,3	98,7	109	124	135	153	171	195	214	kW
	Power input	15,3	18,5	20,3	23,7	26,9	32,6	35,0	40,0	43,7	50,5	55,4	63,4	69,8	kW
	COP	3,12	3,11	3,08	3,11	3,06	3,03	3,11	3,10	3,09	3,03	3,09	3,08	3,07	W/W
A7C45	Heating capacity	49,4	58,4	63,9	75,0	85,9	99,3	111	122	137	156	173	196	218	kW
	Power input	14,6	17,6	19,3	22,6	25,6	31,0	33,3	38,1	41,6	48,1	52,7	60,4	66,4	kW
	COP	3,39	3,31	3,31	3,33	3,35	3,20	3,33	3,21	3,30	3,24	3,27	3,25	3,28	W/W
SP	Low noise setting up (AS)	40.2	50.2	60.2	70.2	80.2	90.2	100.2	115.2	130.2	145.2	160.2	180.2	200.2	
A35E5	Cooling capacity	45,4	54,9	59,6	69,7	76,8	92,4	103	114	126	143	160	185	205	kW
	Power input	15,9	19,8	21,6	25,2	28,3	33,8	37,4	41,6	46,6	52,7	59,0	66,4	74,5	kW
	EER	2,86	2,77	2,76	2,77	2,71	2,73	2,75	2,74	2,70	2,71	2,71	2,79	2,75	W/W
A7C50	Heating capacity	46,6	56,0	61,1	71,9	80,2	96,2	106	121	132	149	167	190	209	kW
	Power input	14,6	17,7	19,4	22,6	25,7	31,1	33,4	38,2	41,7	48,2	52,9	60,5	66,7	kW
	COP	3,19	3,16	3,15	3,18	3,12	3,09	3,17	3,17	3,17	3,09	3,16	3,14	3,13	W/W
A7C45	Heating capacity	47,9	56,7	61,9	72,7	83,2	96,3	107	119	133	152	167	191	212	kW
	Power input	13,9	16,9	18,5	21,5	24,5	29,6	31,8	36,4	39,7	45,9	50,4	57,6	63,5	kW
	COP	3,44	3,36	3,35	3,38	3,40	3,25	3,37	3,28	3,36	3,30	3,31	3,31	3,34	W/W
SP	eXtra low noise setting up (AX)	40.2	50.2	60.2	70.2	80.2	90.2	100.2	115.2	130.2	145.2	160.2	180.2	200.2	
A35E5	Cooling capacity	44,5	53,7	58,4	68,3	75,3	90,5	101	111	124	140	157	180	201	kW
	Power input	17,0	20,9	22,8	26,6	29,9	35,7	39,5	44,0	49,2	55,6	62,3	70,3	78,7	kW
	EER	2,62	2,57	2,56	2,57	2,52	2,54	2,56	2,52	2,52	2,52	2,52	2,56	2,55	W/W
A7C50	Heating capacity	44,9	54,0	58,9	69,4	77,4	92,8	103	117	127	144	161	183	201	kW
	Power input	13,9	16,8	18,5	21,6	24,5	29,7	31,9	36,4	39,8	46,0	50,4	57,7	63,5	kW
	COP	3,23	3,21	3,18	3,21	3,16	3,12	3,23	3,21	3,19	3,13	3,19	3,17	3,17	W/W
A7C45	Heating capacity	46,8	55,3	60,5	71,1	81,3	94,0	105	115	130	147	164	186	206	kW
	Power input	13,2	16,0	17,6	20,6	23,3	28,3	30,4	34,7	37,9	43,8	48,0	54,9	60,5	kW
	COP	3,53	3,46	3,44	3,46	3,49	3,33	3,46	3,32	3,44	3,37	3,41	3,38	3,41	W/W

The values are referred to units without options and accessories.
EER (Energy Efficiency Ratio) = ratio of the total cooling capacity to the effective power input of the unit
COP (Coefficient Of Performance) = ratio of the total heating capacity to the effective power input of the unit

A35E5 = source : air in 35°C d.b. / plant : evaporation temperature (dew point) 5°C - superheating 5°C
A7C50 = source : air in 7°C d.b. 6°C w.b. / plant : condensation temperature (dew point) 50°C - subcooling 5°C
A7C45 = source : air in 7°C d.b. 6°C w.b. / plant : condensation temperature (dew point) 45°C - subcooling 5°C

Acoustic performances

Base setting up (AB)	40.2	50.2	60.2	70.2	80.2	90.2	100.2	115.2	130.2	145.2	160.2	180.2	200.2	
Sound power level	82	82	83	84	84	85	85	85	86	87	87	88	88	dB(A)
Sound pressure level at 1 meter	64	64	65	66	66	67	67	67	68	69	69	69	69	dB(A)
Sound pressure level at 5 meters	55	55	56	57	57	58	58	58	59	60	60	61	61	dB(A)
Sound pressure level at 10 meters	50	50	51	52	52	53	53	53	54	55	55	56	56	dB(A)
Low noise setting up (AS)	40.2	50.2	60.2	70.2	80.2	90.2	100.2	115.2	130.2	145.2	160.2	180.2	200.2	
Sound power level	79	79	80	81	81	82	82	82	83	84	84	85	85	dB(A)
Sound pressure level at 1 meter	61	61	62	63	63	64	64	64	65	66	66	66	66	dB(A)
Sound pressure level at 5 meters	52	52	53	54	54	55	55	55	56	57	57	58	58	dB(A)
Sound pressure level at 10 meters	47	47	48	49	49	50	50	50	51	52	52	53	53	dB(A)
eXtra low noise setting up (AX)	40.2	50.2	60.2	70.2	80.2	90.2	100.2	115.2	130.2	145.2	160.2	180.2	200.2	
Sound power level	77	77	78	79	79	80	80	80	81	82	82	83	83	dB(A)
Sound pressure level at 1 meter	59	59	60	61	61	62	62	62	63	64	64	64	64	dB(A)
Sound pressure level at 5 meters	50	50	51	52	52	53	53	53	54	55	55	56	56	dB(A)
Sound pressure level at 10 meters	45	45	46	47	47	48	48	48	49	50	50	51	51	dB(A)

The values are referred to units without options and accessories.

The acoustic performances are referred to units operating in cooling mode at nominal conditions A35E5.

Unit placed in free field on reflecting surface (directional factor equal to 2).

The sound power level is measured according to ISO 9614 standard.

The sound pressure level is calculated according to ISO 3744 and is referred to a distance of 1/5/10 metres from the external surface of the unit.

Technical data

Unit	40.2	50.2	60.2	70.2	80.2	90.2	100.2	115.2	130.2	145.2	160.2	180.2	200.2		
Power supply	400 - 3+N - 50					400 - 3 - 50								V-ph-Hz	
Compressor type														scroll	-
N° compressors / N° refrigerant circuits														2 / 1	n°
Source side heat exchanger type														finned coil	-
Fans type														axial	-
N° fans	2		3			2			3		4			n°	
Liquid line connection	7/8"					1 1/8"					1 3/8"			-	
Gas line connection	1 5/8"					2 1/8"								-	

Electrical data

Standard unit	40.2	50.2	60.2	70.2	80.2	90.2	100.2	115.2	130.2	145.2	160.2	180.2	200.2	
FLA - Full load current at maximum tolerated conditions	40,2	45,7	53,3	58,7	69,6	75,5	90,0	97,9	106	123	136	159	170	A
FLI - Full load power input at maximum tolerated conditions	21,6	24,4	28,4	31,0	36,2	44,0	55,0	60,5	66,0	75,7	83,3	95,4	103	kW
MIC - Maximum instantaneous current of the unit	134	143	149	173	213	264	259	267	267	348	361	355	391	A
MIC SS - Maximum instantaneous current of the unit with soft starter options	89,3	96,3	101	117	143	174	175	183	183	200	246	248	272	A

Operative range

Temperature	Unit type	Cooling		Heating		°C
		min	max	min	max	
Outdoor air inlet temperature	SR, SP	-10*	45	-7	40*	°C
Evaporating temperature (dew point)	SR, SP	1	15	-	-	°C
Condensing temperature (dew point)	SP	-	-	30	60	°C
Water outlet temperature (VD)	SR, SP	30	70	30	70	(°C)

* with fans modulating control option (condensation / evaporation control)

VD and VR versions

These units allow to recover the heating power, otherwise wasted on air, through an additional heat exchanger. The **Desuperheater Version (VD)** allow the hot water production at temperatures between 30 and 70°C through the partial heat recovery of the condensation heat. **The Total Recovery Version (VR)** allows the cold water production and, at the same time, the hot water production at temperatures between 30 and 55°C through the total recovery of the condensation heat.

Desupeheater Version (VD) - NOMINAL performances

SR	Base setting up (AB)	40.2	50.2	60.2	70.2	80.2	90.2	100.2	115.2	130.2	145.2	160.2	180.2	200.2	
A35E5 - W45	Cooling capacity	50,9	60,1	65,8	77,3	88,4	102	115	126	142	161	177	202	225	kW
	Total power input	15,1	17,9	19,8	23,0	26,8	31,1	34,4	38,2	43,1	49,3	54,7	61,8	68,4	kW
	EER	3,37	3,36	3,32	3,36	3,30	3,28	3,34	3,30	3,29	3,27	3,24	3,27	3,29	W/W
	Heating recovery capacity	14,8	17,4	19,1	22,4	25,6	29,6	33,2	36,5	41,0	46,6	51,5	58,6	65,1	kW
	Water flow rate recovery	0,70	0,83	0,91	1,07	1,22	1,42	1,59	1,74	1,96	2,23	2,46	2,80	3,11	l/s
	Water pressure drop recovery	7	11	13	17	22	18	22	12	16	20	24	20	24	kPa
SP	Base setting up (AB)	40.2	50.2	60.2	70.2	80.2	90.2	100.2	115.2	130.2	145.2	160.2	180.2	200.2	
A35E5 - W45	Cooling capacity	49,2	59,4	64,6	75,5	83,2	100	111	124	137	155	173	200	222	kW
	Total power input	14,9	18,1	19,8	23,1	25,9	30,9	34,2	38,1	42,6	48,2	54,0	60,8	68,1	kW
	EER	3,30	3,28	3,26	3,27	3,21	3,24	3,25	3,25	3,22	3,22	3,20	3,29	3,26	W/W
	Heating recovery capacity	14,3	17,2	18,7	21,9	24,1	29,1	32,2	35,8	39,7	45,0	50,2	58,0	64,5	kW
	Water flow rate recovery	0,68	0,82	0,89	1,05	1,15	1,39	1,54	1,71	1,90	2,15	2,40	2,77	3,08	l/s
	Water pressure drop recovery	7	11	12	17	20	17	20	12	15	19	23	20	23	kPa

Total Recovery Version (VR) - NOMINAL performances

SR	Base setting up (AB)	40.2	50.2	60.2	70.2	80.2	90.2	100.2	115.2	130.2	145.2	160.2	180.2	200.2	
A35E5 - W45	Cooling capacity	50,9	60,1	65,8	77,3	88,4	102	115	126	142	161	177	202	225	kW
	Total power input	14,9	17,7	19,6	22,7	26,5	30,8	34,1	37,8	42,7	48,8	54,1	61,2	67,7	kW
	EER	3,42	3,40	3,36	3,41	3,34	3,31	3,37	3,33	3,33	3,30	3,27	3,30	3,32	W/W
	Heating recovery capacity	65,0	76,9	84,5	98,9	114	131	147	162	182	207	229	260	289	kW
	Water flow rate recovery	3,11	3,67	4,04	4,73	5,43	6,28	7,02	7,73	8,70	9,89	10,9	12,4	13,8	l/s
	Water pressure drop recovery	41	57	48	53	59	58	62	56	61	61	62	65	65	kPa

Data declared according to EN 14511. The values are referred to units without options and accessories.

EER (Energy Efficiency Ratio) = ratio of the total cooling capacity to the effective power input of the unit

HRE (Heat Recovery Efficiency) = ratio of the total capacity of the system (heating plus cooling capacity) to the effective power input

A35W7 - W45 = source : air in 35°C d.b. / plant : water in 12°C out 7°C / Recovery : water in 40°C out 45°C

CONTROL SYSTEM

The units are equipped with a controller designed to ensure energy saving and unit efficiency. Available functions :

- Adaptive function
- Dynamic defrost
- Sound management
- Climatic control in heating and in cooling mode
- Economy function
- Demand limit
- Integrative heating
- Remote stand by
- Remote cooling-heating



DIMENSIONS - MINIMUM OPERATING AREA - WEIGHT

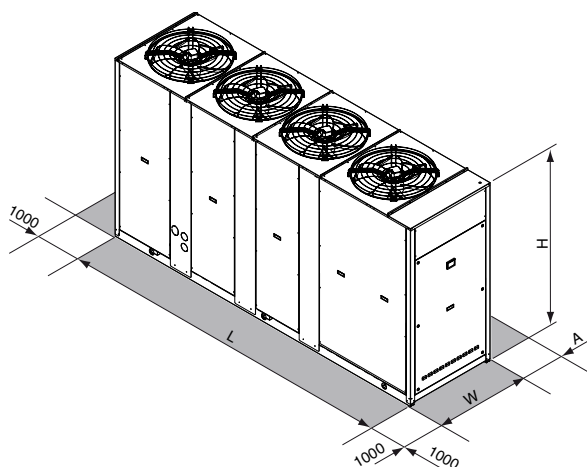

	40.2	50.2	60.2	70.2	80.2	90.2	100.2	115.2	130.2	145.2	160.2	180.2	200.2	
L			2480				3322			3322		4080		mm
W			954				1104			1104		1104		mm
H			1930				1793			2193		2193		mm
A				1600						2000				mm
Operating maximum weight	635	639	639	680	705	953	1034	1065	1181	1240	1292	1435	1481	kg

> CGA HE

CONDENSING UNITS FOR OUTDOOR INSTALLATION



Available range

Unit type

- SR Condensing unit
- SP Heat pump condensing unit
(reversible on the refrigerant side)

Version

- VB Base version
- VD Desuperheater version
- VR Total recovery version

Acoustic setting up

- AB Base setting up
- AS Low noise setting up
- AX eXtra low noise setting up

Source temperature level

- M Medium temperature level
- A High temperature level

Unit description

This series of condensing units satisfies the cooling and heating requirements of residential plants of medium size.

All the units are suitable for outdoor installation and can be connected to a remote heat exchanger properly designed in order to transfer to the plant all the cooling (and heating for reversible units) power generated.

The refrigerant circuit, contained in a compartment protected from the air flow to simplify the maintenance operations, is equipped with scroll compressors mounted on damper supports, thermostatic expansion valve (only for SP), reverse cycle valve, axial fans with safety protec-

tion grilles, finned coil made of copper pipes and aluminium louvered fins with sub-cooling section. The circuit is protected by a safety gas valve, high and low pressure switches.

All the units can be equipped with variable speed fans control that allows the units to operate with low outdoor temperatures in cooling and high outdoor temperature in heating and permits to reduce noise emissions in such operating conditions.

The low noise acoustic setting up (AS) is obtained, starting from the base setting up (AB), reducing the rotational speed of the fans and mounting sound jackets on the compressors and the technical compartment is clad with soundproofing material of suitable thickness.

The eXtra low noise acoustic setting up (AX) is obtained, starting from the low noise setting up (AS), further reducing the rotational speed of the fans and using finned coil with bigger surface.

All the units are supplied with a management and control electrical panel containing general switch, phase presence and correct sequence controller, microprocessor controller with display and all the other electrical components with IP54 minimum protection degree.

All the units are accurately built and individually tested in the factory.

All the units are supplied with refrigerant charge inside.

Only electric and refrigerant connections (between condensing unit and remote heat exchanger) are required for installation.

Options

Compressor starting

- standard (contactors)
- soft starter

Fans control

- on-off control
- modulating control (condensation / evaporation control)

Compressor power factor correction

Electrical load protection

- fuses
- thermal magnetic circuit breakers

Coil condensate tray

Accessories

Rubber vibration dampers

Spring vibration dampers

Coil protection grilles

Remote control

Modbus serial interface on RS485

Programmer clock

Phase sequence and voltage controller

Low temperature kit (standard for SP)

High and low pressure gauges

High temperature thermostat

Coil shut off valves

Outdoor air sensor

Remote plate heat exchanger

Liquid line

NOMINAL performances

SR	Base setting up (AB)	40.2	50.2	60.2	70.2	80.2	90.2	100.2	115.2	130.2	145.2	160.2	180.2	
A35E5	Cooling capacity	51,2	60,7	68,5	76,7	90,5	103,0	116	131	145	166	188	214	kW
	Power input	14,8	17,0	19,7	21,8	27,0	30,9	34,3	38,3	42,3	49,5	54,8	63,9	kW
	EER	3,46	3,57	3,48	3,52	3,35	3,33	3,38	3,42	3,43	3,35	3,43	3,35	W/W
SR	Low noise setting up (AS)	40.2	50.2	60.2	70.2	80.2	90.2	100.2	115.2	130.2	145.2	160.2	180.2	
A35E5	Cooling capacity	48,8	57,9	65,2	73,1	86,3	98,2	110	124	138	159	179	204	kW
	Power input	15,4	17,7	20,5	22,7	27,5	31,8	35,4	39,6	43,9	51,0	56,8	65,7	kW
	EER	3,17	3,27	3,18	3,22	3,14	3,09	3,11	3,13	3,14	3,12	3,15	3,11	W/W
SR	eXtra low noise setting up (AX)	40.2	50.2	60.2	70.2	80.2	90.2	100.2	115.2	130.2	145.2	160.2	180.2	
A35E5	Cooling capacity	48,0	56,8	64,2	71,8	84,8	96,6	108	122	136	156	176	200	kW
	Power input	15,6	18,0	20,7	23,0	27,8	32,2	35,8	40,2	44,7	51,5	57,4	66,4	kW
	EER	3,08	3,16	3,10	3,12	3,05	3,00	3,02	3,03	3,04	3,03	3,07	3,01	W/W
SP	Base setting up (AB)	40.2	50.2	60.2	70.2	80.2	90.2	100.2	115.2	130.2	145.2	160.2	180.2	
A35E5	Cooling capacity	49,1	58,2	65,9	73,7	88,2	100,2	112	125	139	160	180	207	kW
	Power input	14,5	16,9	19,3	21,5	26,5	30,0	33,6	37,5	41,4	48,1	53,8	62,2	kW
	EER	3,39	3,44	3,41	3,43	3,33	3,34	3,33	3,33	3,36	3,33	3,35	3,33	W/W
A7C50	Heating capacity	49,2	58,0	65,6	73,6	87,9	99,8	112	125	140	160	180	206	kW
	Power input	15,3	17,8	20,4	22,9	27,4	31,0	34,8	39,0	43,5	50,0	55,9	64,2	kW
	COP	3,22	3,26	3,22	3,21	3,21	3,22	3,22	3,21	3,22	3,20	3,22	3,21	W/W
A7C45	Heating capacity	51,7	61,3	69,2	77,5	91,4	104,0	117	132	146	168	190	216	kW
	Power input	14,6	16,9	19,4	21,8	26,1	29,5	33,1	37,1	41,4	47,6	53,2	61,1	kW
	COP	3,55	3,62	3,56	3,55	3,50	3,53	3,54	3,56	3,54	3,52	3,57	3,54	W/W
SP	Low noise setting up (AS)	40.2	50.2	60.2	70.2	80.2	90.2	100.2	115.2	130.2	145.2	160.2	180.2	
A35E5	Cooling capacity	46,8	55,4	62,7	70,2	84,0	95,5	107	119	133	152	172	198	kW
	Power input	15,1	17,6	20,0	22,4	27,0	30,8	34,6	38,8	43,0	49,5	55,7	63,9	kW
	EER	3,10	3,15	3,14	3,13	3,11	3,10	3,09	3,07	3,09	3,07	3,09	3,10	W/W
A7C50	Heating capacity	47,9	56,5	63,9	71,7	85,6	97,2	109	122	136	156	175	201	kW
	Power input	14,7	17,2	19,7	22,2	26,0	29,6	33,4	37,5	42,0	47,9	53,7	61,4	kW
	COP	3,26	3,28	3,24	3,23	3,29	3,28	3,26	3,25	3,24	3,26	3,26	3,27	W/W
A7C45	Heating capacity	49,3	58,5	65,9	73,8	87,2	99,2	111	125	139	161	181	206	kW
	Power input	14,0	16,4	18,8	21,1	24,8	28,2	31,8	35,7	40,0	45,6	51,1	58,5	kW
	COP	3,52	3,57	3,51	3,49	3,52	3,52	3,49	3,51	3,49	3,52	3,54	3,52	W/W
SP	eXtra low noise setting up (AX)	40.2	50.2	60.2	70.2	80.2	90.2	100.2	115.2	130.2	145.2	160.2	180.2	
A35E5	Cooling capacity	46,0	54,5	61,7	69,0	82,6	93,9	105	118	131	150	168	194	kW
	Power input	15,3	17,9	20,3	22,7	27,3	31,2	35,1	39,4	43,7	50,0	56,3	64,6	kW
	EER	3,01	3,04	3,04	3,04	3,03	3,01	2,99	2,99	3,00	3,00	2,98	3,00	W/W
A7C50	Heating capacity	47,4	55,8	63,1	70,8	84,6	96,0	108	120	135	154	173	198	kW
	Power input	14,5	16,9	19,3	21,7	25,5	29,0	32,7	36,8	41,2	46,8	52,6	60,1	kW
	COP	3,27	3,30	3,27	3,26	3,32	3,31	3,30	3,26	3,28	3,29	3,29	3,29	W/W
A7C45	Heating capacity	48,5	57,4	64,8	72,5	85,6	97,6	109	123	137	158	178	202	kW
	Power input	13,8	16,1	18,4	20,7	24,3	27,6	31,1	35,0	39,2	44,6	50,1	57,2	kW
	COP	3,51	3,57	3,53	3,51	3,53	3,53	3,50	3,52	3,50	3,54	3,55	3,53	W/W

The values are referred to units without options and accessories.
EER (Energy Efficiency Ratio) = ratio of the total cooling capacity to the effective power input of the unit
COP (Coefficient Of Performance) = ratio of the total heating capacity to the effective power input of the unit

A35E5 = source : air in 35°C d.b. / plant : evaporation temperature (dew point) 5°C - superheating 5°C
A7C50 = source : air in 7°C d.b. 6°C w.b. / plant : condensation temperature (dew point) 50°C - subcooling 5°C
A7C45 = source : air in 7°C d.b. 6°C w.b. / plant : condensation temperature (dew point) 45°C - subcooling 5°C

Acoustic performances

Base setting up (AB)	40.2	50.2	60.2	70.2	80.2	90.2	100.2	115.2	130.2	145.2	160.2	180.2	
Sound power level	82	82	83	84	85	85	85	85	86	87	87	88	dB(A)
Sound pressure level at 1 meter	64	64	65	66	67	67	67	67	68	69	69	69	dB(A)
Sound pressure level at 5 meters	55	55	56	57	58	58	58	58	59	60	60	61	dB(A)
Sound pressure level at 10 meters	50	50	51	52	53	53	53	53	54	55	55	56	dB(A)
Low noise setting up (AS)	40.2	50.2	60.2	70.2	80.2	90.2	100.2	115.2	130.2	145.2	160.2	180.2	
Sound power level	79	79	80	81	82	82	82	82	83	84	84	85	dB(A)
Sound pressure level at 1 meter	61	61	62	63	64	64	64	64	65	66	66	66	dB(A)
Sound pressure level at 5 meters	52	52	53	54	55	55	55	55	56	57	57	58	dB(A)
Sound pressure level at 10 meters	47	47	48	49	50	50	50	50	51	52	52	53	dB(A)
eXtra low noise setting up (AX)	40.2	50.2	60.2	70.2	80.2	90.2	100.2	115.2	130.2	145.2	160.2	180.2	
Sound power level	77	77	78	79	80	80	80	80	81	82	82	83	dB(A)
Sound pressure level at 1 meter	59	59	60	61	62	62	62	62	63	64	64	64	dB(A)
Sound pressure level at 5 meters	50	50	51	52	53	53	53	53	54	55	55	56	dB(A)
Sound pressure level at 10 meters	45	45	46	47	48	48	48	48	49	50	50	51	dB(A)

The values are referred to units without options and accessories.

The acoustic performances are referred to units operating in cooling mode at nominal conditions A35E5.

Unit placed in free field on reflecting surface (directional factor equal to 2).

The sound power level is measured according to ISO 9614 standard.

The sound pressure level is calculated according to ISO 3744 and is referred to a distance of 1/5/10 metres from the external surface of the unit.

Technical data

Unit	40.2	50.2	60.2	70.2	80.2	90.2	100.2	115.2	130.2	145.2	160.2	180.2		
Power supply	400 - 3+N - 50				400 - 3 - 50								V-ph-Hz	
Compressor type	scroll												-	
N° compressors / N° refrigerant circuits	2 / 1												n°	
Source side heat exchanger type	finned coil												-	
Fans type	axial												-	
N° fans	2	3							2	3	4			n°
Liquid line connection	7/8"				1 1/8"				1 3/8"				-	
Gas line connection	1 5/8"				2 1/8"								-	

Electrical data

Standard unit	40.2	50.2	60.2	70.2	80.2	90.2	100.2	115.2	130.2	145.2	160.2	180.2	
FLA - Full load current at maximum tolerated conditions	40,2	45,7	53,3	58,7	69,6	75,5	90,0	97,9	106	123	136	159	A
FLI - Full load power input at maximum tolerated conditions	21,6	24,4	28,4	31,0	36,2	44,0	55,0	60,5	66,0	75,7	83,3	95,4	kW
MIC - Maximum instantaneous current of the unit	134	143	149	173	213	264	259	267	267	348	361	355	A
MIC SS - Maximum instantaneous current of the unit with soft starter options	89,3	96,3	101	117	143	174	175	183	183	200	246	248	A

Operative range

Temperature	Unit type	Cooling		Heating		
		min	max	min	max	
Outdoor air inlet temperature	SR, SP	-10*	45	-7	40*	°C
Evaporating temperature (dew point)	SR, SP	1	15	-	-	°C
Condensing temperature (dew point)	SP	-	-	30	60	°C
Water outlet temperature (VD)	SR, SP	30	70	30	70	(°C)

* with fans modulating control option (condensation / evaporation control)

VD and VR versions

These units allow to recover the heating power, otherwise wasted on air, through an additional heat exchanger. The **Desuperheater Version (VD)** allow the hot water production at temperatures between 30 and 70°C through the partial heat recovery of the condensation heat. **The Total Recovery Version (VR)** allows the cold water production and, at the same time, the hot water production at temperatures between 30 and 55°C through the total recovery of the condensation heat.

Desuperheater Version (VD) - NOMINAL performances

SR	Base setting up (AB)	40.2	50.2	60.2	70.2	80.2	90.2	100.2	115.2	130.2	145.2	160.2	180.2	
A35E5 - W45	Cooling capacity	53,2	63,1	71,2	79,7	94,1	107	120	136	151	173	195	222	kW
	Total power input	14,4	16,5	19,1	21,1	26,2	30,0	33,2	37,2	41,1	48,0	53,2	62,0	kW
	EER	3,69	3,82	3,73	3,78	3,59	3,57	3,61	3,66	3,67	3,60	3,67	3,58	W/W
	Heating recovery capacity	15,4	18,3	20,7	23,1	27,3	31,1	34,9	39,4	43,6	50,2	56,7	64,5	kW
	Water flow rate recovery	0,74	0,87	0,99	1,10	1,30	1,48	1,67	1,88	2,09	2,40	2,71	3,08	l/s
	Water pressure drop recovery	8	12	15	18	25	20	24	14	18	24	29	24	kPa
SP	Base setting up (AB)	40.2	50.2	60.2	70.2	80.2	90.2	100.2	115.2	130.2	145.2	160.2	180.2	
A35E5 - W45	Cooling capacity	51,1	60,5	68,5	76,6	91,8	104	117	130	145	166	188	216	kW
	Total power input	14,1	16,4	18,7	20,8	25,7	29,1	32,6	36,4	40,2	46,6	52,2	60,3	kW
	EER	3,62	3,69	3,66	3,68	3,57	3,57	3,59	3,57	3,61	3,56	3,60	3,58	W/W
	Heating recovery capacity	14,8	17,6	19,9	22,2	26,6	30,2	33,9	37,8	42,0	48,2	54,4	62,5	kW
	Water flow rate recovery	0,71	0,84	0,95	1,06	1,27	1,44	1,62	1,81	2,01	2,30	2,60	2,99	l/s
	Water pressure drop recovery	7	11	14	17	24	19	22	13	17	22	27	23	kPa

Total Recovery Version (VR) - NOMINAL performances

SR	Base setting up (AB)	40.2	50.2	60.2	70.2	80.2	90.2	100.2	115.2	130.2	145.2	160.2	180.2	
A35E5 - W45	Cooling capacity	53,2	63,1	71,2	79,7	94,1	107	120	136	151	173	195	222	kW
	Total power input	14,2	16,4	18,9	20,9	25,9	29,7	32,9	36,8	40,6	47,5	52,6	61,4	kW
	EER	3,75	3,85	3,77	3,81	3,63	3,60	3,65	3,70	3,72	3,64	3,71	3,62	W/W
	Heating recovery capacity	66,8	78,7	89,1	99,6	119	135	151	171	189	218	245	281	kW
	Water flow rate recovery	3,19	3,76	4,26	4,76	5,68	6,47	7,23	8,16	9,03	10,42	11,7	13,4	l/s
	Water pressure drop recovery	43	60	54	53	64	61	65	63	66	67	71	76	kPa

Data declared according to **EN 14511**. The values are referred to units without options and accessories.
EER (Energy Efficiency Ratio) = ratio of the total cooling capacity to the effective power input of the unit
HRE (Heat Recovery Efficiency) = ratio of the total capacity of the system (heating plus cooling capacity) to the effective power input
A35W7 - W45 = source : air in 35°C d.b. / plant : water in 12°C out 7°C / Recovery : water in 40°C out 45°C

CONTROL SYSTEM

The units are equipped with a controller designed to ensure energy saving and unit efficiency. Available functions :

- Adaptive function
- Dynamic defrost
- Sound management
- Climatic control in heating and in cooling mode
- Economy function
- Demand limit
- Integrative heating
- Remote stand by
- Remote cooling-heating



DIMENSIONS - MINIMUM OPERATING AREA - WEIGHT

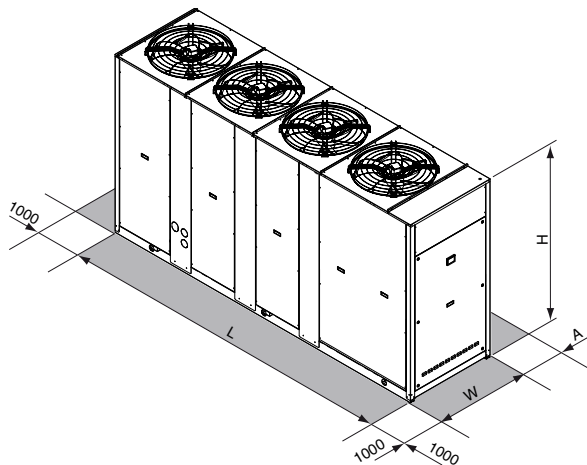

	40.2	50.2	60.2	70.2	80.2	90.2	100.2	115.2	130.2	145.2	160.2	180.2	
L		2480				3322			3322		4080		mm
W		954				1104			1104		1104		mm
H		1930				1793			2193		2193		mm
A		1600							2000				mm
Operating maximum weight	635	639	639	680	705	953	1034	1065	1181	1240	1292	1435	kg



Available range

Unit type

- SR Condensing unit
- SP Heat pump condensing unit (reversible on the refrigerant side)

Version

- VB Base version
- VD Desuperheater version
- VR Total recovery version

Acoustic setting up

- AB Base setting up
- AS Low noise setting up

Source temperature level

- M Medium temperature level
- A High temperature level

Unit description

This series of condensing units satisfies the cooling and heating requirements of residential plants of medium size.

All the units are suitable for outdoor installation and can be connected to a remote heat exchanger properly designed in order to transfer to the plant all the cooling (and heating for reversible units) power generated.

The refrigerant circuit, contained in a compartment protected from the air flow to simplify the maintenance operations, is equipped with scroll compressors mounted on

damper supports, thermostatic expansion valve (only for SP), reverse cycle valve, double inlet centrifugal fans with forward curved blades, finned coil made of copper pipes and aluminium louvered fins with subcooling section. The circuit is protected by a safety gas valve, high and low pressure switches.

All the units can be equipped with variable speed fans control that allows the units to operate with low outdoor temperatures in cooling and high outdoor temperature in heating and permits to reduce noise emissions in such operating conditions.

The low noise acoustic setting up (AS) is obtained, starting from the base setting up (AB), mounting sound jackets on the compressors and the technical compartment is clad with soundproofing material of suitable thickness.

All the units are supplied with a management and control electrical panel containing general switch, phase presence and correct sequence controller, microprocessor controller with display and all the other electrical components with IP54 minimum protection degree.

All the units are accurately built and individually tested in the factory.

All the units are supplied with refrigerant charge inside.

Only electric and refrigerant connections (between condensing unit and remote heat exchanger) are required for installation.

Options

Compressor starting

- standard (contactors)
- soft starter

Fans control

- on-off control
- modulating control INVERTER (condensation / evaporation control)

Compressor power factor correction Electrical load protection

- fuses
- thermal magnetic circuit breakers

Coil condensate tray

(standard for SP)

Accessories

Rubber vibration dampers

Spring vibration dampers

Coil protection grilles

Remote control

Modbus serial interface on RS485

Programmer clock

Phase sequence and voltage controller

Low temperature kit (standard for SP)

High and low pressure gauges

High temperature thermostat

Coil shut off valves

Outdoor air sensor

Remote plate heat exchanger

Liquid line

NOMINAL performances

SR	Base setting up (AB)	40.2	50.2	60.2	70.2	80.2	90.2	100.2	115.2	130.2	145.2	160.2	180.2	200.2	
A35E5	Cooling capacity	48,9	57,8	63,3	74,3	85,0	98,3	110	121	136	154	171	194	216	kW
	Power input	15,5	18,4	20,5	23,7	27,6	32,1	35,5	39,4	44,5	50,8	56,3	63,7	70,6	kW
	EER	3,15	3,14	3,09	3,14	3,08	3,06	3,10	3,07	3,06	3,03	3,04	3,05	3,06	W/W
SR	Low noise setting up (AS)	40.2	50.2	60.2	70.2	80.2	90.2	100.2	115.2	130.2	145.2	160.2	180.2	200.2	
A35E5	Cooling capacity	48,9	57,8	63,3	74,3	85,0	98,3	110	121	136	154	171	194	216	kW
	Power input	15,5	18,4	20,5	23,7	27,6	32,1	35,5	39,4	44,5	50,8	56,3	63,7	70,6	kW
	EER	3,15	3,14	3,09	3,14	3,08	3,06	3,10	3,07	3,06	3,03	3,04	3,05	3,06	W/W
SP	Base setting up (AB)	40.2	50.2	60.2	70.2	80.2	90.2	100.2	115.2	130.2	145.2	160.2	180.2	200.2	
A35E5	Cooling capacity	47,3	57,1	62,1	72,6	80,0	96,3	107	119	132	149	166	192	214	kW
	Power input	15,3	18,6	20,4	23,8	26,7	31,9	35,3	39,3	43,9	49,7	55,6	62,7	70,3	kW
	EER	3,09	3,07	3,04	3,05	3,00	3,02	3,03	3,03	3,01	3,00	2,99	3,06	3,04	W/W
A7C50	Heating capacity	47,8	57,5	62,6	73,8	82,3	98,7	109	124	135	153	171	195	214	kW
	Power input	15,3	18,5	20,3	23,7	26,9	32,6	35,0	40,0	43,7	50,5	55,4	63,4	69,8	kW
	COP	3,12	3,11	3,08	3,11	3,06	3,03	3,11	3,10	3,09	3,03	3,09	3,08	3,07	W/W
A7C45	Heating capacity	52,6	63,3	68,9	81,2	90,5	109	120	136	149	168	188	215	235	kW
	Power input	13,5	16,3	17,9	20,9	23,7	28,7	30,8	35,2	38,5	44,4	48,8	55,8	61,4	kW
	COP	3,90	3,88	3,85	3,89	3,82	3,80	3,90	3,86	3,87	3,78	3,85	3,85	3,83	W/W
SP	Low noise setting up (AS)	40.2	50.2	60.2	70.2	80.2	90.2	100.2	115.2	130.2	145.2	160.2	180.2	200.2	
A35E5	Cooling capacity	47,3	57,1	62,1	72,6	80,0	96,3	107	119	132	149	166	192	214	kW
	Power input	15,3	18,6	20,4	23,8	26,7	31,9	35,3	39,3	43,9	49,7	55,6	62,7	70,3	kW
	EER	3,09	3,07	3,04	3,05	3,00	3,02	3,03	3,03	3,01	3,00	2,99	3,06	3,04	W/W
A7C50	Heating capacity	47,8	57,5	62,6	73,8	82,3	98,7	109	124	135	153	171	195	214	kW
	Power input	15,3	18,5	20,3	23,7	26,9	32,6	35,0	40,0	43,7	50,5	55,4	63,4	69,8	kW
	COP	3,12	3,11	3,08	3,11	3,06	3,03	3,11	3,10	3,09	3,03	3,09	3,08	3,07	W/W
A7C45	Heating capacity	52,6	63,3	68,9	81,2	90,5	109	120	136	149	168	188	215	235	kW
	Power input	13,5	16,3	17,9	20,9	23,7	28,7	30,8	35,2	38,5	44,4	48,8	55,8	61,4	kW
	COP	3,90	3,88	3,85	3,89	3,82	3,80	3,90	3,86	3,87	3,78	3,85	3,85	3,83	W/W

The values are referred to units without options and accessories.
EER (Energy Efficiency Ratio) = ratio of the total cooling capacity to the effective power input of the unit
COP (Coefficient Of Performance) = ratio of the total heating capacity to the effective power input of the unit

A35E5 = source : air in 35°C d.b. / plant : evaporation temperature (dew point) 5°C - superheating 5°C
A7C50 = source : air in 7°C d.b. 6°C w.b. / plant : condensation temperature (dew point) 50°C - subcooling 5°C
A7C45 = source : air in 7°C d.b. 6°C w.b. / plant : condensation temperature (dew point) 45°C - subcooling 5°C

Acoustic performances

Base setting up (AB)	40.2	50.2	60.2	70.2	80.2	90.2	100.2	115.2	130.2	145.2	160.2	180.2	200.2	
Sound power level	88	88	89	89	89	91	91	91	96	97	97	98	98	dB(A)
Sound pressure level at 1 meter	70	70	71	71	71	73	73	73	78	79	79	80	80	dB(A)
Sound pressure level at 5 meters	61	61	62	62	62	65	65	65	69	70	70	71	71	dB(A)
Sound pressure level at 10 meters	56	56	57	57	57	59	59	59	64	65	65	66	66	dB(A)
Low noise setting up (AS)	40.2	50.2	60.2	70.2	80.2	90.2	100.2	115.2	130.2	145.2	160.2	180.2	200.2	
Sound power level	85	85	86	86	86	88	88	88	93	94	94	95	95	dB(A)
Sound pressure level at 1 meter	67	67	68	68	68	70	70	70	75	76	76	77	77	dB(A)
Sound pressure level at 5 meters	58	58	59	59	59	62	62	62	66	67	67	68	68	dB(A)
Sound pressure level at 10 meters	53	53	54	54	54	56	56	56	61	62	62	63	63	dB(A)

The values are referred to units without options and accessories.

The acoustic performances are referred to units operating in cooling mode at nominal conditions A35E5.

Unit placed in free field on reflecting surface (directional factor equal to 2).

The sound power level is measured according to ISO 9614 standard.

The sound pressure level is calculated according to ISO 3744 and is referred to a distance of 1/5/10 metres from the external surface of the unit.

Technical data

Unit	40.2	50.2	60.2	70.2	80.2	90.2	100.2	115.2	130.2	145.2	160.2	180.2	200.2	
Power supply	400 - 3 - 50													V-ph-Hz
Compressor type	scroll													-
N° compressors / N° refrigerant circuits	2 / 1													n°
Source side heat exchanger type	finned coil													-
Fans type	centrifugal													-
N° fans	1			2			3			4			n°	
Liquid line connection	7/8"			1 1/8"			1 3/8"			-			-	
Gas line connection	1 5/8"			2 1/8"			-			-			-	

Electrical data

Standard unit	40.2	50.2	60.2	70.2	80.2	90.2	100.2	115.2	130.2	145.2	160.2	180.2	200.2	
FLA - Full load current at maximum tolerated conditions	43,2	48,8	56,7	62,1	73,0	80,5	95,0	103	117	145	158	188	199	A
FLI - Full load power input at maximum tolerated conditions	25,2	28,0	33,0	35,6	40,8	47,3	58,3	63,8	72,8	88,7	96,3	113	120	kW
MIC - Maximum instantaneous current of the unit	137	147	152	177	216	269	264	272	278	370	383	384	420	A
MIC SS - Maximum instantaneous current of the unit with soft starter options	92,4	99,4	105	121	147	179	180	188	194	222	268	277	301	A

Operative range

Temperature	Unit type	Cooling		Heating		
		min	max	min	max	
Outdoor air inlet temperature	SR, SP	-10*	48	-10	40*	°C
Evaporating temperature (dew point)	SR, SP	1	20	-	-	°C
Condensing temperature (dew point)	SP	-	-	35	60	°C
Water outlet temperature (VD)	SR, SP	30	70	30	70	(°C)
Water outlet temperature (VR)	SR	30	55	-	-	(°C)

* with fans modulating control option (condensation / evaporation control)

Aeraulic performance

Unit	40.2	50.2	60.2	70.2	80.2	90.2	100.2	115.2	130.2	145.2	160.2	180.2	200.2	
Available static head	150	150	150	150	150	150	150	150	150	150	150	150	150	Pa

VD and VR versions

These units allow to recover the heating power, otherwise wasted on air, through an additional heat exchanger. The **Desuperheater Version (VD)** allow the hot water production at temperatures between 30 and 70°C through the partial heat recovery of the condensation heat.

The **Total Recovery Version (VR)** allows the cold water production and, at the same time, the hot water production at temperatures between 30 and 55°C through the total recovery of the condensation heat.

Desupeheater Version (VD) - NOMINAL performances

SR	Base setting up (AB)	40.2	50.2	60.2	70.2	80.2	90.2	100.2	115.2	130.2	145.2	160.2	180.2	200.2	
A35E5 - W45	Cooling capacity	50,9	60,1	65,8	77,3	88,4	102	115	126	142	161	177	202	225	kW
	Total power input	15,1	17,9	19,8	23,0	26,8	31,1	34,4	38,2	43,1	49,3	54,7	61,8	68,4	kW
	EER	3,37	3,36	3,32	3,36	3,30	3,28	3,34	3,30	3,29	3,27	3,24	3,27	3,29	W/W
	Heating recovery capacity	14,8	17,4	19,1	22,4	25,6	29,6	33,2	36,5	41,0	46,6	51,5	58,6	65,1	kW
	Water flow rate recovery	0,70	0,83	0,91	1,07	1,22	1,42	1,59	1,74	1,96	2,23	2,46	2,80	3,11	l/s
	Water pressure drop recovery	7	11	13	17	22	18	22	12	16	20	24	20	24	kPa
SP	Base setting up (AB)	40.2	50.2	60.2	70.2	80.2	90.2	100.2	115.2	130.2	145.2	160.2	180.2	200.2	
A35E5 - W45	Cooling capacity	49,2	59,4	64,6	75,5	83,2	100	111	124	137	155	173	200	222	kW
	Total power input	14,9	18,1	19,8	23,1	25,9	30,9	34,2	38,1	42,6	48,2	54,0	60,8	68,1	kW
	EER	3,30	3,28	3,26	3,27	3,21	3,24	3,25	3,25	3,22	3,22	3,20	3,29	3,26	W/W
	Heating recovery capacity	14,3	17,2	18,7	21,9	24,1	29,1	32,2	35,8	39,7	45,0	50,2	58,0	64,5	kW
	Water flow rate recovery	0,68	0,82	0,89	1,05	1,15	1,39	1,54	1,71	1,90	2,15	2,40	2,77	3,08	l/s
	Water pressure drop recovery	7	11	12	17	20	17	20	12	15	19	23	20	23	kPa

Total Recovery Version (VR) - NOMINAL performances

SR	Base setting up (AB)	40.2	50.2	60.2	70.2	80.2	90.2	100.2	115.2	130.2	145.2	160.2	180.2	200.2	
A35E5 - W45	Cooling capacity	50,9	60,1	65,8	77,3	88,4	102	115	126	142	161	177	202	225	kW
	Total power input	14,9	17,7	19,6	22,7	26,5	30,8	34,1	37,8	42,7	48,8	54,1	61,2	67,7	kW
	EER	3,42	3,40	3,36	3,41	3,34	3,31	3,37	3,33	3,33	3,30	3,27	3,30	3,32	W/W
	Heating recovery capacity	65,0	76,9	84,5	98,9	114	131	147	162	182	207	229	260	289	kW
	Water flow rate recovery	3,11	3,67	4,04	4,73	5,43	6,28	7,02	7,73	8,70	9,89	10,9	12,4	13,8	l/s
	Water pressure drop recovery	41	57	48	53	59	58	62	56	61	61	62	65	65	kPa

Data declared according to EN 14511. The values are referred to units without options and accessories.

EER (Energy Efficiency Ratio) = ratio of the total cooling capacity to the effective power input of the unit

HRE (Heat Recovery Efficiency) = ratio of the total capacity of the system (heating plus cooling capacity) to the effective power input

A35W7 - W45 = source : air in 35°C d.b. / plant : water in 12°C out 7°C / Recovery : water in 40°C out 45°C

CONTROL SYSTEM

The units are equipped with a controller designed to ensure energy saving and unit efficiency. Available functions :

- Adaptive function
- Dynamic defrost
- Sound management
- Climatic control in heating and in cooling mode
- Economy function
- Demand limit
- Integrative heating
- Remote stand by
- Remote cooling-heating



DIMENSIONS - MINIMUM OPERATING AREA - WEIGHT

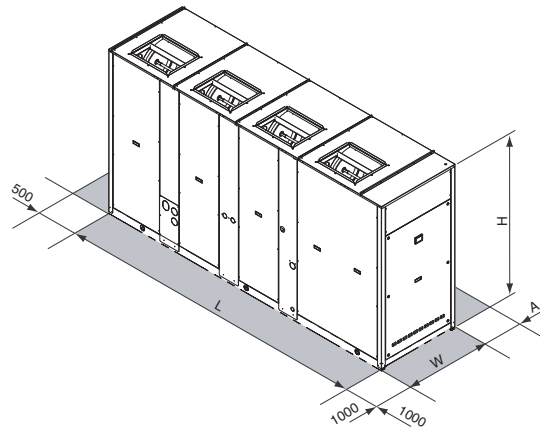

	40.2	50.2	60.2	70.2	80.2	90.2	100.2	115.2	130.2	145.2	160.2	180.2	200.2	
L			2480				3322			3322		4080		mm
W			954				1104			1104		1104		mm
H			1760				1760			2160		2160		mm
A			1600							2000				mm
Operating maximum weight	1078	1082	1102	1143	1168	1684	1765	1825	2000	2042	2094	2423	2467	kg

> CGC HE

CONDENSING UNITS FOR INDOOR INSTALLATION



Available range

Unit type

- SR Condensing unit
- SP Heat pump condensing unit (reversible on the refrigerant side)

Version

- VB Base version
- VD Desuperheater version
- VR Total recovery version

Acoustic setting up

- AB Base setting up
- AS Low noise setting up

Source temperature level

- M Medium temperature level
- A High temperature level

Unit description

This series of condensing units satisfies the cooling and heating requirements of residential plants of medium size.

All the units are suitable for outdoor installation and can be connected to a remote heat exchanger properly designed in order to transfer to the plant all the cooling (and heating for reversible units) power generated.

The refrigerant circuit, contained in a compartment protected from the air flow to simplify the maintenance operations, is equipped with scroll compressors mounted on

damper supports, thermostatic expansion valve (only for SP), reverse cycle valve, double inlet centrifugal fans with forward curved blades, finned coil made of copper pipes and aluminium louvered fins with subcooling section. The circuit is protected by a safety gas valve, high and low pressure switches.

All the units can be equipped with variable speed fans control that allows the units to operate with low outdoor temperatures in cooling and high outdoor temperature in heating and permits to reduce noise emissions in such operating conditions.

The low noise acoustic setting up (AS) is obtained, starting from the base setting up (AB), mounting sound jackets on the compressors and the technical compartment is clad with soundproofing material of suitable thickness.

All the units are supplied with a management and control electrical panel containing general switch, phase presence and correct sequence controller, microprocessor controller with display and all the other electrical components with IP54 minimum protection degree.

All the units are accurately built and individually tested in the factory.

All the units are supplied with refrigerant charge inside.

Only electric and refrigerant connections (between condensing unit and remote heat exchanger) are required for installation.

Options

Compressor starting

- standard (contactors)
- soft starter

Fans control

- on-off control
- modulating control INVERTER (condensation / evaporation control)

Compressor power factor correction Electrical load protection

- fuses
- thermal magnetic circuit breakers

Coil condensate tray

(standard for SP)

Accessories

Rubber vibration dampers

Spring vibration dampers

Coil protection grilles

Remote control

Modbus serial interface on RS485

Programmer clock

Phase sequence and voltage controller

Low temperature kit (standard for SP)

High and low pressure gauges

High temperature thermostat

Coil shut off valves

Outdoor air sensor

Remote plate heat exchanger

Liquid line

NOMINAL performances

SR	Base setting up (AB)	40.2	50.2	60.2	70.2	80.2	90.2	100.2	115.2	130.2	145.2	160.2	180.2	
A35E5	Cooling capacity	51,2	60,7	68,5	76,7	90,5	103,0	116	131	145	166	188	214	kW
	Power input	14,8	17,0	19,7	21,8	27,0	30,9	34,3	38,3	42,3	49,5	54,8	63,9	kW
	EER	3,46	3,57	3,48	3,52	3,35	3,33	3,38	3,42	3,43	3,35	3,43	3,35	W/W
SR	Low noise setting up (AS)	40.2	50.2	60.2	70.2	80.2	90.2	100.2	115.2	130.2	145.2	160.2	180.2	
A35E5	Cooling capacity	51,2	60,7	68,5	76,7	90,5	103,0	116	131	145	166	188	214	kW
	Power input	14,8	17,0	19,7	21,8	27,0	30,9	34,3	38,3	42,3	49,5	54,8	63,9	kW
	EER	3,46	3,57	3,48	3,52	3,35	3,33	3,38	3,42	3,43	3,35	3,43	3,35	W/W
SP	Base setting up (AB)	40.2	50.2	60.2	70.2	80.2	90.2	100.2	115.2	130.2	145.2	160.2	180.2	
A35E5	Cooling capacity	49,1	58,2	65,9	73,7	88,2	100,2	112	125	139	160	180	207	kW
	Power input	14,5	16,9	19,3	21,5	26,5	30,0	33,6	37,5	41,4	48,1	53,8	62,2	kW
	EER	3,39	3,44	3,41	3,43	3,33	3,34	3,33	3,33	3,36	3,33	3,35	3,33	W/W
A7C50	Heating capacity	49,2	58,0	65,6	73,6	87,9	99,8	112	125	140	160	180	206	kW
	Power input	15,3	17,8	20,4	22,9	27,4	31,0	34,8	39,0	43,5	50,0	55,9	64,2	kW
	COP	3,22	3,26	3,22	3,21	3,21	3,22	3,22	3,21	3,22	3,20	3,22	3,21	W/W
A7C45	Heating capacity	54,1	63,8	72,2	81,0	96,7	110	123	138	154	176	198	227	kW
	Power input	13,5	15,7	18,0	20,2	24,1	27,3	30,6	34,3	38,3	44,0	49,2	56,5	kW
	COP	4,01	4,06	4,01	4,01	4,01	4,03	4,02	4,02	4,02	4,00	4,02	4,02	W/W
SP	Low noise setting up (AS)	40.2	50.2	60.2	70.2	80.2	90.2	100.2	115.2	130.2	145.2	160.2	180.2	
A35E5	Cooling capacity	49,1	58,2	65,9	73,7	88,2	100,2	112	125	139	160	180	207	kW
	Power input	14,5	16,9	19,3	21,5	26,5	30,0	33,6	37,5	41,4	48,1	53,8	62,2	kW
	EER	3,39	3,44	3,41	3,43	3,33	3,34	3,33	3,33	3,36	3,33	3,35	3,33	W/W
A7C50	Heating capacity	49,2	58,0	65,6	73,6	87,9	99,8	112	125	140	160	180	206	kW
	Power input	15,3	17,8	20,4	22,9	27,4	31,0	34,8	39,0	43,5	50,0	55,9	64,2	kW
	COP	3,22	3,26	3,22	3,21	3,21	3,22	3,22	3,21	3,22	3,20	3,22	3,21	W/W
A7C45	Heating capacity	54,1	63,8	72,2	81,0	96,7	110	123	138	154	176	198	227	kW
	Power input	13,5	15,7	18,0	20,2	24,1	27,3	30,6	34,3	38,3	44,0	49,2	56,5	kW
	COP	4,01	4,06	4,01	4,01	4,01	4,03	4,02	4,02	4,02	4,00	4,02	4,02	W/W

The values are referred to units without options and accessories.
EER (Energy Efficiency Ratio) = ratio of the total cooling capacity to the effective power input of the unit
COP (Coefficient Of Performance) = ratio of the total heating capacity to the effective power input of the unit

A35E5 = source : air in 35°C d.b. / plant : evaporation temperature (dew point) 5°C - superheating 5°C
A7C50 = source : air in 7°C d.b. 6°C w.b. / plant : condensation temperature (dew point) 50°C - subcooling 5°C
A7C45 = source : air in 7°C d.b. 6°C w.b. / plant : condensation temperature (dew point) 45°C - subcooling 5°C

Acoustic performances

Base setting up (AB)	40.2	50.2	60.2	70.2	80.2	90.2	100.2	115.2	130.2	145.2	160.2	180.2	
Sound power level	88	88	89	89	91	91	91	96	96	97	97	98	dB(A)
Sound pressure level at 1 meter	70	70	71	71	73	73	73	78	78	79	79	80	dB(A)
Sound pressure level at 5 meters	61	61	62	62	65	65	65	69	69	70	70	71	dB(A)
Sound pressure level at 10 meters	56	56	57	57	59	59	59	64	64	65	65	66	dB(A)
Low noise setting up (AS)	40.2	50.2	60.2	70.2	80.2	90.2	100.2	115.2	130.2	145.2	160.2	180.2	
Sound power level	85	85	86	86	88	88	88	93	93	94	94	95	dB(A)
Sound pressure level at 1 meter	67	67	68	68	70	70	70	75	75	76	76	77	dB(A)
Sound pressure level at 5 meters	58	58	59	59	62	62	62	66	66	67	67	68	dB(A)
Sound pressure level at 10 meters	53	53	54	54	56	56	56	61	61	62	62	63	dB(A)

The values are referred to units without options and accessories.

The acoustic performances are referred to units operating in cooling mode at nominal conditions A35E5.

Unit placed in free field on reflecting surface (directional factor equal to 2).

The sound power level is measured according to ISO 9614 standard.

The sound pressure level is calculated according to ISO 3744 and is referred to a distance of 1/5/10 metres from the external surface of the unit.

Technical data

Unit	40.2	50.2	60.2	70.2	80.2	90.2	100.2	115.2	130.2	145.2	160.2	180.2	
Power supply	400 - 3 - 50												V-ph-Hz
Compressor type	scroll												-
N° compressors / N° refrigerant circuits	2 / 1												n°
Source side heat exchanger type	finned coil												-
Fans type	centrifugal												-
N° fans	1			2			3			4			n°
Liquid line connection	7/8"			1 1/8"			1 3/8"			-			-
Gas line connection	1 5/8"			2 1/8"			-			-			-

Electrical data

Standard unit	40.2	50.2	60.2	70.2	80.2	90.2	100.2	115.2	130.2	145.2	160.2	180.2	
FLA - Full load current at maximum tolerated conditions	43,2	48,8	56,7	62,1	74,9	80,5	95,0	109	117	145	169	188	A
FLI - Full load power input at maximum tolerated conditions	25,2	28,0	33,0	35,6	41,9	47,3	58,3	67,3	72,8	88,7	103	113	kW
MIC - Maximum instantaneous current of the unit	137	147	152	177	218	269	264	278	278	370	394	384	A
MIC SS - Maximum instantaneous current of the unit with soft starter options	92,4	99,4	105	121	148	179	180	194	194	222	279	277	A

Operative range

Temperature	Unit type	Cooling		Heating		
		min	max	min	max	
Outdoor air inlet temperature	SR, SP	-10*	48	-15	40*	°C
Evaporating temperature (dew point)	SR, SP	1	20	-	-	°C
Condensing temperature (dew point)	SP	-	-	35	60	°C
Water outlet temperature (VD)	SR, SP	30	70	30	70	(°C)
Water outlet temperature (VR)	SR	30	55	-	-	(°C)

* with fans modulating control option (condensation / evaporation control)

Aeraulic performance

Unit	40.2	50.2	60.2	70.2	80.2	90.2	100.2	115.2	130.2	145.2	160.2	180.2	
Available static head	150	150	150	150	150	150	150	150	150	150	150	150	Pa

VD AND VR VERSIONS

These units allow to recover the heating power, otherwise wasted on air, through an additional heat exchanger.

The **Desuperheater Version (VD)** allow the hot water production at temperatures between 30 and 70°C through the partial heat recovery of the condensation heat.

The **Total Recovery Version (VR)** allows the cold water production and, at the same time, the hot water production at temperatures between 30 and 55°C through the total recovery of the condensation heat.

Desuperheater Version (VD) - NOMINAL performances

SR	Base setting up (AB)	40.2	50.2	60.2	70.2	80.2	90.2	100.2	115.2	130.2	145.2	160.2	180.2	
A35E5 - W45	Cooling capacity	53,2	63,1	71,2	79,7	94,1	107	120	136	151	173	195	222	kW
	Total power input	14,4	16,5	19,1	21,1	26,2	30,0	33,2	37,2	41,1	48,0	53,2	62,0	kW
	EER	3,69	3,82	3,73	3,78	3,59	3,57	3,61	3,66	3,67	3,60	3,67	3,58	W/W
	Heating recovery capacity	15,4	18,3	20,7	23,1	27,3	31,1	34,9	39,4	43,6	50,2	56,7	64,5	kW
	Water flow rate recovery	0,74	0,87	0,99	1,10	1,30	1,48	1,67	1,88	2,09	2,40	2,71	3,08	l/s
	Water pressure drop recovery	8	12	15	18	25	20	24	14	18	24	29	24	kPa
SP	Base setting up (AB)	40.2	50.2	60.2	70.2	80.2	90.2	100.2	115.2	130.2	145.2	160.2	180.2	
A35E5 - W45	Cooling capacity	51,1	60,5	68,5	76,6	91,8	104	117	130	145	166	188	216	kW
	Total power input	14,1	16,4	18,7	20,8	25,7	29,1	32,6	36,4	40,2	46,6	52,2	60,3	kW
	EER	3,62	3,69	3,66	3,68	3,57	3,57	3,59	3,57	3,61	3,56	3,60	3,58	W/W
	Heating recovery capacity	14,8	17,6	19,9	22,2	26,6	30,2	33,9	37,8	42,0	48,2	54,4	62,5	kW
	Water flow rate recovery	0,71	0,84	0,95	1,06	1,27	1,44	1,62	1,81	2,01	2,30	2,60	2,99	l/s
	Water pressure drop recovery	7	11	14	17	24	19	22	13	17	22	27	23	kPa

Total Recovery Version (VR) - NOMINAL performances

SR	Base setting up (AB)	40.2	50.2	60.2	70.2	80.2	90.2	100.2	115.2	130.2	145.2	160.2	180.2	
A35E5 - W45	Cooling capacity	53,2	63,1	71,2	79,7	94,1	107	120	136	151	173	195	222	kW
	Total power input	14,2	16,4	18,9	20,9	25,9	29,7	32,9	36,8	40,6	47,5	52,6	61,4	kW
	EER	3,75	3,85	3,77	3,81	3,63	3,60	3,65	3,70	3,72	3,64	3,71	3,62	W/W
	Heating recovery capacity	66,8	78,7	89,1	99,6	119	135	151	171	189	218	245	281	kW
	Water flow rate recovery	3,19	3,76	4,26	4,76	5,68	6,47	7,23	8,16	9,03	10,42	11,7	13,4	l/s
	Water pressure drop recovery	43	60	54	53	64	61	65	63	66	67	71	76	kPa

Data declared according to **EN 14511**. The values are referred to units without options and accessories.
EER (Energy Efficiency Ratio) = ratio of the total cooling capacity to the effective power input of the unit
HRE (Heat Recovery Efficiency) = ratio of the total capacity of the system (heating plus cooling capacity) to the effective power input
A35W7 - W45 = source : air in 35°C d.b. / plant : water in 12°C out 7°C / Recovery : water in 40°C out 45°C

CONTROL SYSTEM

The units are equipped with a controller designed to ensure energy saving and unit efficiency. Available functions :

- Adaptive function
- Dynamic defrost
- Sound management
- Climatic control in heating and in cooling mode
- Economy function
- Demand limit
- Integrative heating
- Remote stand by
- Remote cooling-heating



DIMENSIONS - MINIMUM OPERATING AREA - WEIGHT

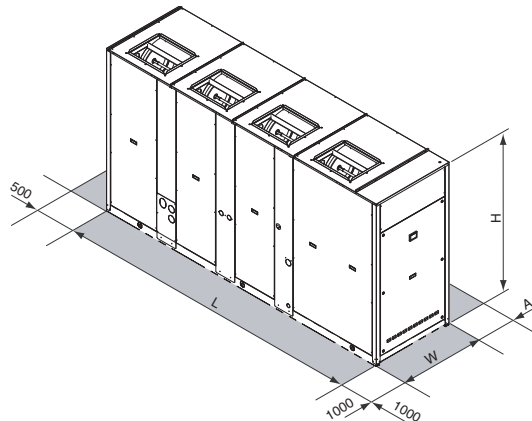

	40.2	50.2	60.2	70.2	80.2	90.2	100.2	115.2	130.2	145.2	160.2	180.2		
L		2480				3322			3322		4080			mm
W		954				1104			1104		1104			mm
H		1760				1760			2160		2160			mm
A		1600							2000					mm
Operating maximum weight	1121	1125	1146	1189	1670	1751	1836	2051	2080	2124	2478	2520	kg	

> EGW

CONDENSERLESS UNITS FOR INDOOR INSTALLATION



Unit with closing panels

Available range

Unit type

- IR Condenserless unit
- BR Condenserless unit Brine

Version

- VB Base version

Acoustic setting up

- AB Base setting up
- AS Low noise setting up
- AX eXtra low noise setting up

Unit description

This series of condenserless unit satisfies the cooling and heating requirements of commercial and industrial plants of medium size.

All the units are suitable for indoor installation and can be applied to fan coil plants and radiant floor plants.

The refrigerant circuit is equipped with 2 scroll compressors, mounted on rubber vibration-damper supports, plant side heat exchanger brazed plate-type in stainless steel (AISI 316), complete with thermal insulation shell and differential pressure switch, thermostatic expansion valve or electronic expansion valve (as option), dehydrator filter, solenoid valve to shut-off the liquid line, shut-off ball valves on

the discharge and liquid lines, refrigerant circuit protected by refrigerant safety valve, low and high pressure switches, electrical panel for power and control complete with main breaker power supply with door lock function microprocessor controller with keyboard-display, and phase sequence controller (standard). The units can be chosen in Basic setting up (AB) (unit without closing panels), Low noise setting up (AS), featuring closing panels coated with acoustic material, Extra Low noise setting up (AX) featuring closing panels coated with superior acoustic material and soundproofing jackets on the compressors.

The units are suitable to be combined with remote condensers cooled by air (coil and fans) or remote condensers cooled by water (plates or shell and tube heat exchanger). The electronic controller can manage the numerous ways used on the market for the head pressure control for condensation by air and for condensation by water. A wide range of options and accessories completes the commercial offer. All the units are carefully built in compliance with the current regulations and individually tested.

The units are supplied with charge of NITROGEN in order to avoid the entrance of air inside the refrigerant circuit.

Options

Expansion valve

- thermostatic
- electronic

Suitable for outdoor installation

Accessories

- Rubber vibration dampers
- Remote controller
- Serial Interface Modbus-RS 485
- Programmer clock
- Phase sequence and voltage controller
- Low temperature kit
- High and low pressure gauges
- High temperature thermostat
- Compressors shut-off valves
- Outdoor air sensor
- Water flow switch
- Victaulic hydraulic fittings
- Victaulic bends
- Victaulic water shut-off valves
- Victaulic water filter
- 2-way valve for condensing control
- 3-way valve for condensing control
- Compressors start-up with soft starter
- Compressors power factor correction
- Electrical load protection with thermal magnetic circuit breakers
- Remote condenser cooled by air

CONTROL SYSTEM

The units are equipped with a controller designed to ensure energy saving and unit efficiency. Available functions :

- Adaptive function
- Climatic control in heating and in cooling mode
- Economy function
- Demand limit
- Condensation control
- Remote stand by



NET NOMINAL performances - Standard plants

IR	70.2	80.2	90.2	105.2	120.2	135.2	150.2	170.2	190.2	215.2	240.2		
C50W7	Cooling capacity	60,7	67,7	80,6	91,5	102,5	115,4	129,3	148,2	167,0	188,9	208,7	kW
	Power input	19,7	21,7	26,2	29,8	33,5	37,8	42,2	48,1	53,9	61,0	68,0	kW
	EER	3,07	3,12	3,08	3,07	3,06	3,05	3,06	3,08	3,10	3,10	3,07	W/W
	Water flow rate source side	2,91	3,25	3,87	4,40	4,92	5,54	6,21	7,12	8,03	9,08	10,0	l/s
	Pressure drops source side	36	28	31	31	34	32	35	35	37	37	38	kPa

Data declared according to **EN 14511**. The values are referred to units without options and accessories.
EER (Energy Efficiency Ratio) = ratio of the total cooling capacity to the effective power input of the unit
C50W7 = condensing temperature (dew point) = 50 °C - subcooling = 5°C - plant : water in 12°C out 7°C

Acoustic performances

Base setting up (AB)	70.2	80.2	90.2	105.2	120.2	135.2	150.2	170.2	190.2	215.2	240.2	
Sound power level	75	76	77	77	77	78	78	79	79	80	80	dB(A)
Sound pressure level at 1 meter	59	60	61	61	61	62	62	63	63	64	64	dB(A)
Sound pressure level at 5 meters	49	50	51	51	51	52	52	53	53	54	54	dB(A)
Sound pressure level at 10 meters	44	45	46	46	46	47	47	48	48	49	49	dB(A)
Low noise setting up (AS)	70.2	80.2	90.2	105.2	120.2	135.2	150.2	170.2	190.2	215.2	240.2	
Sound power level	71	72	73	73	73	74	74	75	75	76	76	dB(A)
Sound pressure level at 1 meter	55	56	57	57	57	58	58	59	59	60	60	dB(A)
Sound pressure level at 5 meters	45	46	47	47	47	48	48	49	49	50	50	dB(A)
Sound pressure level at 10 meters	40	41	42	42	42	43	43	44	44	45	45	dB(A)
eXtra low noise setting up (AX)	70.2	80.2	90.2	105.2	120.2	135.2	150.2	170.2	190.2	215.2	240.2	
Sound power level	67	68	69	69	69	70	70	71	71	72	72	dB(A)
Sound pressure level at 1 meter	51	52	53	53	53	54	54	55	55	56	56	dB(A)
Sound pressure level at 5 meters	41	42	43	43	43	44	44	45	45	46	46	dB(A)
Sound pressure level at 10 meters	36	37	38	38	38	39	39	40	40	41	41	dB(A)

The acoustic performances are referred to units operating in cooling mode at nominal conditions C50W7.
 Unit placed in free field on reflecting surface (directional factor equal to 2).
 The sound power level is measured according to ISO 9614 standard.
 The sound pressure level is calculated according to ISO 3744 and is referred to a distance of 1/5/10 metres from the external surface of the unit.

Technical data

Unit	70.2	80.2	90.2	105.2	120.2	135.2	150.2	170.2	190.2	215.2	240.2	
Power supply	400 - 3 - 50											V-ph-Hz
Max working pressure (HP-PS)	43											bar
Compressor type	scroll											-
N° compressors / N° refrigerant circuits	2 / 1											n°
Plant side heat exchanger type	stainless steel brazed plates											-
IN/OUT Plant side hydraulic fittings	2" 1/2 VICTAULIC											"
Refrigerant liquid line fitting	28 ODS					35 ODS						mm
Refrigerant gas line fitting	42 ODS											mm

Electrical data

Standard unit	70.2	80.2	90.2	105.2	120.2	135.2	150.2	170.2	190.2	215.2	240.2	
FLA - Full load current at maximum tolerated conditions	45	51	62	68	74	82	90	105	120	142	164	A
FLI - Full load power input at maximum tolerated conditions	26	29	34	40	45	50	55	63	72	83	93	kW
MIC - Maximum instantaneous current of the unit	141	166	204	256	262	309	317	355	370	454	476	A

Operating range

Cooling

Temperature	Unit type	min	max	
Condensing temp (dew point)	IR, BR	30	60	(°C)
Water outlet temperature plant side	IR	5	20	(°C)
Water outlet temperature plant side	BR	-12	5	(°C)

DIMENSIONS - MINIMUM OPERATING AREA - WEIGHT

(reference drawing: unit with closing panel)

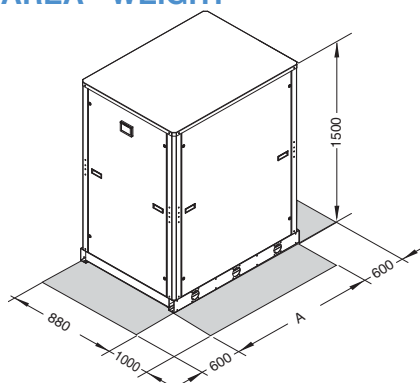

Models	70.2	80.2	90.2	105.2	120.2	135.2	150.2	170.2	190.2	215.2	240.2		
A	880											1175	mm
Operating maximum weight	368	378	385	501	581	607	632	669	694	724	747	kg	

Remote condenser

This series of remote axial condensers uses copper pipes with special internal riffling and a high efficiency fin.

The fin has been specially designed to guarantee a high thermal exchange coefficient with low air pressure drops. By combining both special tubes and fins the following features can be achieved:

- Maximum capacity related to the heat exchanger's dimensions.
- Minimum refrigerant charge.
- The most strict environment standards for sound pollution can be met.

This new series of axial condensers is equipped with fans with scythe-shaped blades to reduce the sound emission. From the noise level point of view, all models can be supplied as basic version (AB), low noise version (AS) or extra low noise version (AX). To guarantee solidity, strength and the maximum resistance to atmospheric agents the bearing and the casing are manufactured with galvanized steel and oven painted with a polyurethane resin (the standard colour is RAL 7035).

Options

- Special fins (Copper, Painted Aluminium, ecc.).
- Special motors
- Vertical / Horizontal air flow
- EC fans



Accessories

All models can be equipped with several accessories as:

- Rubber Vibrations Dampers
- Modulating control of the fans with cut of phase regulator
- Modulating control of the fans with inverter regulator
- Electrical Wiring Box, allows a fast and safe electrical installation of the unit since all wires and thermal protections of the fans are connected inside a waterproof box (IP54) to a terminal block where the installer connect the electrical supply and the fans thermal switches signal.
- Electrical Panel CE this accessory (like the electrical wiring box) allows a fast and safe electrical installation and moreover simplify the standard and non standard maintenance of the unit. The accessory is in fact composed by main electrical switch, fuses and contactors of the fans, transformer to supply an alarm auxiliary relè, terminal block for remote ON-OFF (i.e. sent by the condenserless unit).

Technical data

Unit	70.2	80.2	90.2	105.2	120.2	135.2	150.2	170.2	190.2	215.2	240.2	
Power supply	400 - 3 - 50											V-ph-Hz
Fan type	axial											-
Max working pressure (PS)	45											bar
Coil exchanger type	Aluminum fins and copper tubes											-

Acoustic performances

Base setting up (AB)	70.2	80.2	90.2	105.2	120.2	135.2	150.2	170.2	190.2	215.2	240.2	
Sound power level	80	80	82	83	83	83	83	85	85	85	85	dB(A)
Sound pressure level at 1 meter	63	63	65	66	66	66	66	68	68	68	68	dB(A)
Sound pressure level at 5 meters	53	53	55	56	56	56	56	58	58	58	58	dB(A)
Sound pressure level at 10 meters	48	48	50	51	51	51	51	53	53	53	53	dB(A)
Low noise setting up (AS)	70.2	80.2	90.2	105.2	120.2	135.2	150.2	170.2	190.2	215.2	240.2	
Sound power level	75	75	76	76	76	76	76	76	77	77	77	dB(A)
Sound pressure level at 1 meter	58	58	57	57	57	59	59	59	60	60	60	dB(A)
Sound pressure level at 5 meters	48	48	47	47	47	49	49	49	50	50	50	dB(A)
Sound pressure level at 10 meters	43	43	42	42	42	44	44	44	45	45	45	dB(A)
eXtra low noise setting up (AX)	70.2	80.2	90.2	105.2	120.2	135.2	150.2	170.2	190.2	215.2	240.2	
Sound power level	68	68	68	68	70	70	70	71	71	73	73	dB(A)
Sound pressure level at 1 meter	51	51	51	51	53	53	53	54	54	56	56	dB(A)
Sound pressure level at 5 meters	41	41	41	41	43	43	43	44	44	46	46	dB(A)
Sound pressure level at 10 meters	36	36	36	36	38	38	38	39	39	41	41	dB(A)

Base setting up (AB)		70.2	80.2	90.2	105.2	120.2	135.2	150.2	170.2	190.2	215.2	240.2	
Refrigerant connections	Gas	1x42	1x42	1x42	1x42	1x42	1x42	1x42	1x42	1x54	1x54	1x54	n° x Ø
	Liquid	1x35	1x35	1x35	1x28	1x35	1x35	1x35	1x35	1x42	1x42	1x42	n° x Ø
Fan specification	Fan	2	2	3	2	2	2	2	3	3	3	3	n°
	Diameter	630	630	630	800	800	800	800	800	800	800	800	mm
	Air flow rate	5556	5556	8917	11778	10889	10889	10222	17667	16333	15333	15333	l/s
	Power input	1,46	1,46	2,19	4,00	4,00	4,00	4,00	6,00	6,00	6,00	6,00	kW
Standard configuration	Length [L]	2630	2630	3770	3230	3230	3230	3230	4580	4580	4580	4580	mm
	Height [A]	1230	1230	1230	1370	1370	1370	1370	1370	1370	1370	1370	mm
	Depth [P]	600	600	600	800	800	800	800	800	800	800	800	mm
Configuration with support brackets	Length [L]	2630	2630	3770	3230	3230	3230	3230	4580	4580	4580	4580	mm
	Height [A]	990	990	990	1565	1565	1565	1565	1565	1565	1565	1565	mm
	Depth [P]	1230	1230	1230	1370	1370	1370	1370	1370	1370	1370	1370	mm
Weight		166	166	221	279	302	302	324	413	447	481	481	kg

Low noise setting up (AS)		70.2	80.2	90.2	105.2	120.2	135.2	150.2	170.2	190.2	215.2	240.2	
Refrigerant connections	Gas	1x42	1x42	1x42	1x42	1x42	1x42	1x54	1x54	2x42	2x42	2x42	n° x Ø
	Liquid	1x35	1x35	1x28	1x35	1x35	1x35	1x42	1x42	2x35	2x35	2x35	n° x Ø
Fan specification	Fan	3	3	2	2	2	3	3	3	4	4	4	n°
	Diameter	630	630	800	800	800	800	800	800	800	800	800	mm
	Air flow rate	6250	6250	9389	7944	7444	14083	11917	11167	15222	14111	14111	l/s
	Power input	0,99	0,99	1,96	1,96	1,96	2,94	2,94	2,94	3,92	3,92	3,92	kW
Standard configuration	Length [L]	3770	3770	3230	3230	3230	4580	4580	4580	3230	3230	3230	mm
	Height [A]	1230	1230	1370	1370	1370	1370	1370	1370	2390	2390	2390	mm
	Depth [P]	600	600	800	800	800	800	800	800	800	800	800	mm
Configuration with support brackets	Length [L]	3770	3770	3230	3230	3230	4580	4580	4580	3230	3230	3230	mm
	Height [A]	990	990	1565	1565	1565	1565	1565	1565	1565	1565	1565	mm
	Depth [P]	1230	1230	1370	1370	1370	1370	1370	1370	2390	2390	2390	mm
Weight		221	221	279	302	324	413	447	481	502	543	543	kg

eXtra low noise setting up (AX)		70.2	80.2	90.2	105.2	120.2	135.2	150.2	170.2	190.2	215.2	240.2	
Refrigerant connections	Gas	1x42	1x42	1x42	1x42	1x42	1x54	1x54	2x42	2x42	2x42	2x42	n° x Ø
	Liquid	1x28	1x28	1x35	1x35	1x35	1x42	1x42	2x35	2x35	2x35	2x35	n° x Ø
Fan specification	Fan	2	2	2	2	3	3	3	4	4	4	4	n°
	Diameter	800	800	800	800	800	800	800	800	800	800	800	mm
	Air flow rate	6778	6778	6111	5611	10167	9167	8417	11556	10667	19333	19333	l/s
	Power input	1,18	1,18	1,18	1,18	1,77	1,77	1,77	2,36	2,36	2,36	2,36	kW
Standard configuration	Length [L]	3230	3230	3230	3230	4580	4580	4580	3230	3230	4580	4580	mm
	Height [A]	1370	1370	1370	1370	1370	1370	1370	2390	2390	2390	2390	mm
	Depth [P]	800	800	800	800	800	800	800	800	800	800	800	mm
Configuration with support brackets	Length [L]	3230	3230	3230	3230	4580	4580	4580	3230	3230	4580	4580	mm
	Height [A]	1565	1565	1565	1565	1565	1565	1565	1565	1565	1565	1565	mm
	Depth [P]	1370	1370	1370	1370	1370	1370	1370	2390	2390	2390	2390	mm
Weight		279	279	302	324	413	447	481	502	543	680	680	kg

Standard configuration (horizontal air flow)

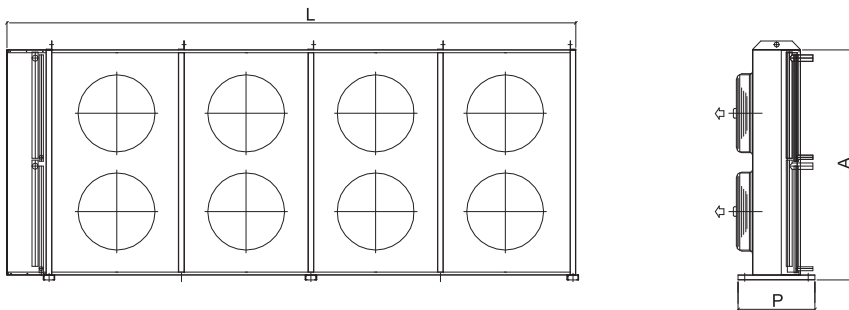

Configuration with Support Brackets (vertical air flow)

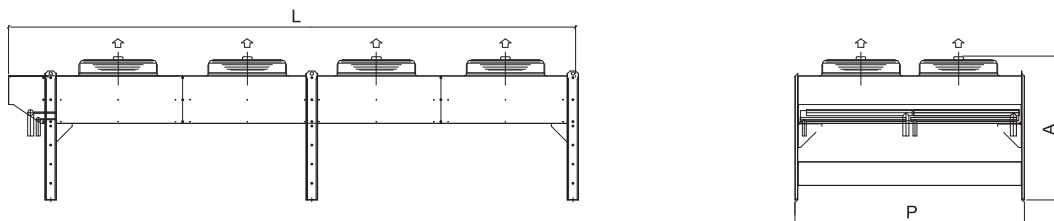

> Main characteristics terminal units

EXPOSED INSTALLATION
CONCEALED INSTALLATION
DUCTABLE TYPE
SERVIZIO AQUASEL

> EXPOSED INSTALLATION

FAN COIL WITH CENTRIFUGAL FANS

Series **TOP FAN PLUS** features 2 versions:

- with cabinet and bottom air intake VM-B
- with cabinet and frontal air intake VM-F
- with 3-rows coil

Range include 9 sizes with air flow-rates up to 1,350 m³/h.



TOP FAN PLUS

JOLLY PLUS 2 WITH CROSS FLOW FANS AND BRUSHLESS MOTOR

Series **JOLLY Plus 2** features 2 versions:

- with cabinet and bottom air intake VM-F
- with cabinet and frontal air intake VM-G

These very compact units are suitable for indoor installations and are amply configurable to meet the needs of highly qualified designers.



JOLLY PLUS 2

CASSETTE FAN COIL

Series **FCM** features 2 versions:

- for standard 2 pipes systems
- For 4 pipes systems

Range is made by four sizes 2-pipes type and two sizes 4-pipes type. Air flow up to 1.850 m³/h.



FCM

WALL-MOUNTED FAN COIL

Series **VTP** supplied with remote control and three-way valve. The range comprises 4 sizes with air flow-rates up to 880 m³/h.



SUPERFAN

> CONCEALED INSTALLATION

FAN COIL TYPE

Fan coil series **TOP FAN PLUS** features 2 versions:

- without cabinet, ceiling concealed, with six-speed motor
- without cabinet, ceiling concealed, with three-speed motor
- with 3-rows

Range include 9 sizes with air flow-rates up to 1,350 m³/h.



Fan coil series **JOLLY Plus 2** features 1 version:

- VN version without cabinet, ceiling concealed

> DUCTABLE TYPE

MERCURY ST

MERCURY ST range features centrifugal fans with mid hydraulic head. 7 sizes available, air flow up to 4200 m³/h, head up to 115 Pa.



MERCURY ST

> AQUASEL SOFTWARE

The Ferrolì design staff has developed software for choosing the right FERROLI terminal unit for your system needs. FERROLI software calculates the performance values according to the inlet air temperature/humidity, the water Dt/temperature and, in the case of ceiling concealed or ducted units, it is possible to set a fan head value and recalculate the efficiency and air flow-rate of the units. There is also the selected choice of accessories the printing of the description of the unit specifications and a complete technical data sheet.

A sales tool much appreciated by professionals for its easy use and prompt answers

For further information, contact your local Ferrolì Industrial Climate Control Branch.

The screenshot shows the AQUASEL software interface with various configuration options on the left and a technical data table on the right. The configuration options include:

- Tipologia: [Unità terminali]
- Installazione: [Ad incasso]
- Tipo: [Orizz-Verticale]
- Tipo di calcolo: [Raffreddamento - Riscaldamento]
- Tipo di impianto: [Impianto 2 tubi]

Configuration parameters include:

- Potenza richiesta [kW]: 0.0
- Fluido: WATER
- Livello sul mare [m]: 0
- Temperatura aria in ingresso [°C]: 27.0 (Fissa) / 20.0 (Cala)
- Umidità relativa in ingresso [%]: 47.0
- Temperatura fluido in ingresso [°C]: 7.0 / 30.0
- Portata fluido velocità massima [m³/h]: 8.0
- Volume ambiente [m³]: 100
- Tempo riverbero [s]: 0.8
- Portata nominale

The table on the right lists available units (SERIE DISPONIBILI) with columns for Serie, Unità, Velocità, Portata aria, IP (Pressure), PF, IPR, Tin, Tout, Flow, RSC, Total, UR, PT, Tm, Tout, Flow, RSC, and Price. The table includes data for various models like FCP 15, FCP 20, FCP 30, etc., up to FCP 120.

(*) Prezzo unità comprensivo di accessori (se obbligatori)

> TOP FAN PLUS

FAN COIL

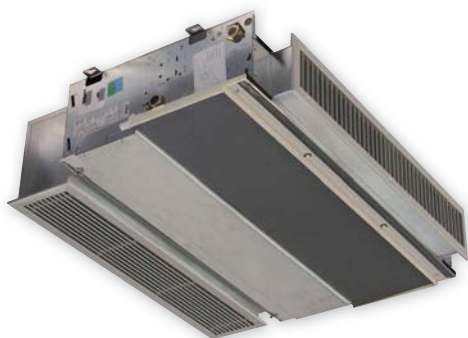

Units Series

Available versions

- VM-B bottom air intake
- VM-F frontal air intake
- VN ceiling concealed 6-speed
- VN-3V ceiling concealed 3-speed

Exchangers

- 3R with 3 rows

VB unit specifications

Fan coil unit complying with Machine Directive 89/392 EEC and amendments 91/368 EEC, 93/44 EEC, 93/68 EEC, Low-Voltage Directives 72/23 EEC and Electromagnetic Compatibility Directives EMC 89/36 EEC. The fan coil unit is a terminal for the treatment of room air in the summer season (coil supplied with cold water) and in winter (coil supplied with hot water). These units are suitable for indoor installation, very compact and amply configurable to meet the requirements of highly qualified designers. The customer or the designer can find version with cabinet and with air intake from bottom (VM-B version) or with frontal air intake and version without cabinet ceiling concealed type with 6 speed fan for a short duct (VN version) or with 3 speed fan. The careful design of the main components, refined styling and the versatility of the product make it suitable for any type of installation in the residential, commercial or industrial context. Installation therefore only requires the electrical and hydraulic connections.

Construction characteristics

- **SUPPORT STRUCTURE:** in galvanised sheet metal of suitable thickness. There are slots at the back for fixing the unit.
- **HEAT EXCHANGE COIL:** copper pipe type arranged in staggered rows to increase heat exchange and aluminium finning in 3 or 4 rows, locked by mechanical expansion of the pipes. The manifolds have air vents, water drain holes and housing for the supply water temperature probe. The connections are located on the left side panel (facing the unit). The possibility of turning the coil is provided for.
- **CONDENSATE TRAY:** in thermoplastic material to prevent corrosion, it enables either vertical and horizontal unit installation. The drain hole is present on both sides.
- **3-speed FAN-MOTOR (versions VM-B VM-F and VN-3V):** the electric motor, protected against overloads, has three speeds with running condenser always on, directly coupled to the fans and cushioned by elastic supports. The dual-intake centrifugal fans have long blades in order to obtain high air flow-rates with reduced revolutions.
- **6-speed FAN-MOTOR (versions VN):** the electric motor has 6 speeds one or three of which selectable during installation to adjust flow-rate and head to the system's characteristics and enable a short ducting in line with the product's characteristics.

- **AIR FILTER:** regenerable simply by washing with water.
For the VM-B version it is provided with a continuous guide in plastic material to facilitate extraction operations. For the VM-F version it is positioned in the front bottom air inlet grill. For the VN and VN-3V version it is complete with frame and wire screen.
- **CABINET (only VM-B and VM-F):** partly in epoxy powder coated steel sheet to ensure high protection against corrosion, and partly in anti-UV thermoplastic material. In the upper part there are air vents and the door for accessing the control panel, both in anti-UV thermoplastic material. The VM-F version also has a front grill in anti-UV thermoplastic material for the air inlet.

Main accessories/Options

ADJUSTMENT CONTROLS

INSTALLATION ON UNIT

- Cabinet switch
- Cabinet standard thermostat
- Cabinet advanced thermostat

REMOTE INSTALLATION

- Remote switch
- Remote standard thermostat
- Remote advanced thermostat

- Hot-start consent thermostat
- Supplementary tray vertical installation
- Supplementary tray horizontal installation
- 3-way valve main coil 3 R
- 2-way valve main coil 3 R
- Supplementary coil heating only
- 3-way valve supplementary coil
- 2-way valve supplementary coil
- Single-phase electrical heater
- Condensate drain pump

VM-B and VM-F ACCESSORIES

- Support feet (VM-B only)
- Adjustable fins
- Outside air inlet damper with front grill (VM-B only)
- Damper motor with single-phase power supply (VM-B only)
- Rear closing panel

VN and VN-3V ACCESSORIES

- Inlet grill
- Straight inlet flange
- Perpendicular inlet flange
- Straight outlet flange
- Perpendicular outlet flange
- Inlet plenum
- Outlet plenum
- Outlet grill

Dimensions

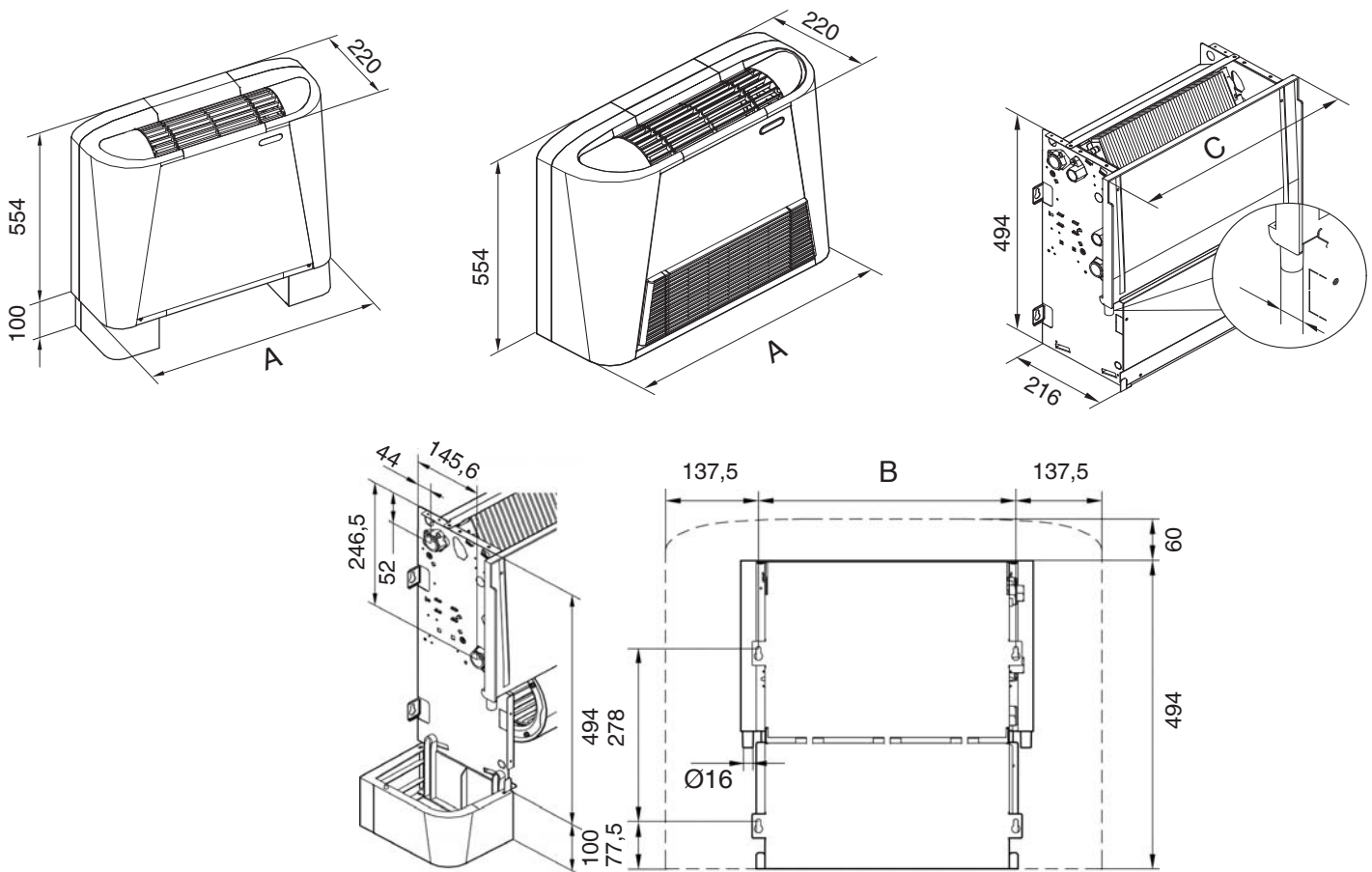

Mod		15 - 20	30 - 40	50 - 60 - 80	100 - 120
A	mm	690	940	1190	1440
B	mm	415	665	915	1165
C	mm	474	724	974	1224

Common Data		15	20	30	40	50	60	80	100	120	
N° fan		1	1	1	1	2	2	2	2	2	N°
Air flow rate	max.	215	280	410	515	615	750	1050	1200	1350	m³/h
	med.	170	210	310	400	510	600	850	970	1070	m³/h
	min	110	140	220	290	350	410	570	670	720	m³/h
VN-3V external static pressure		0	0	0	0	0	0	0	0	0	Pa
VN external static pressure		20	20	40	40	40	50	50	30	30	Pa
Heating capacity electrical heater		800	800	1500	1500	2200	2200	2200	2600	2600	W
VM-B unit weight	3 rows	15	15	21	21	28	28	28	36	36	kg
VM-F unit weight	3 rows	14	14	20	20	27	27	27	34	34	kg
VN e VN-3V unit weight	3 rows	11	11	15	15	22	22	22	29	29	kg
VM-B unit weight	4 rows	15.8	15.8	22.5	22.5	30	30	30	39	39	kg
VM-F unit weight	4 rows	14.8	14.8	21.5	21.5	29	29	29	37	37	kg
VN unit weight	4 rows	11.8	11.8	16.5	16.5	24	24	25	32	32	kg
Condensation draining connections		16	16	16	16	16	16	16	16	16	Ø

4 rows coil data

		15-4	20-4	30-4	40-4	50-4	60-4	80-4	100-4	120-4	
Total Cooling Capacity *	max.	1400	1760	2790	3580	4050	4890	6450	7450	8200	W
	med.	1220	1460	2290	2940	3510	4020	5680	6620	7160	W
	min	900	1090	1700	2200	2500	2980	4000	5020	5250	W
Sensible Cooling Capacity *	max.	1050	1305	2060	2580	2950	3540	4950	5580	6210	W
	med.	890	1050	1640	2070	2510	2900	4200	4850	5330	W
	min	620	770	1200	1560	1770	2130	2910	3600	3820	W
Dehumidifying max speed		500	650	1050	1450	1580	1930	2330	2650	2850	g/h
Water flow rate *		240.8	302.72	479.88	615.76	696.6	841.08	1109.4	1281.4	1410.4	l/h
Water pressure drop		6	9	9	14	14	21	36	19	23	Kpa
Heating Capacity **	max.	3050	3950	5880	6950	8350	10100	13200	15800	16900	W
	med.	2580	3300	4730	5750	7260	8270	11300	13400	14310	W
	min	1900	2400	3600	4430	5460	6080	8450	10250	10500	W
Water flow rate **		262.3	339.7	505.68	597.7	718.1	868.6	1135.2	1358.8	1453.4	l/h
Water pressure drop **		5	8	7	10	11	16	27	15	18	Kpa
Heating Capacity ***		1850	2380	3460	4250	5000	5800	8100	9300	10500	W
Water pressure drop ***		5	8	8	13	12	18	32	16	20	Kpa
N° fans		1	1	1	2	2	2	2	2	2	N°
Max power input motor		35	38	55	76	75	85	144	163	200	W
Sound power level	max.	45	48	52	54	53	55	61	63	65	dB(A)
	med.	39	42	45	47	46	50	58	59	60	dB(A)
	min	32	35	39	41	37	39	48	51	52	dB(A)
Sound pressure level	max.	36	39	43	45	44	46	52	54	56	dB(A)
	med.	30	33	36	38	37	41	49	50	51	dB(A)
	min	23	26	30	32	28	30	39	42	43	dB(A)
Water connection 4R	F	3/4"	3/4"	3/4"	3/4"	3/4"	3/4"	3/4"	3/4"	3/4"	"
Water content 4R coil		1.09	1.09	1.68	1.68	2.51	2.51	2.51	3.23	3.23	l

NOTES:

* Room Air T=27°C D.B. / 19°C W.B. , IN/OUT water 7°/12°C, nominal air flow-rate; For medium and minimum fan speed, water delivery as in maximum speed.

** Room Air T=20°C D.B. , IN/OUT water 70°/60°C, nominal air flow-rate; for medium and minimum fan speed, water delivery as in maximum speed.

*** Room Air T=20°C D.B. , inlet water 50°C, water delivery as in cooling; Values referred to nominal air flow-rate.

SWL : Sound power levels, referred to 1x10-12 W in dB(A), measured in accordance with Standard ISO 9614 and certified according to the Eurovent certification programme. Eurovent certification (E) only refers to the Total Sound Power in dB(A) which is therefore the only binding acoustic data.

SPL : sound pressure in a 100 m3 place with reverberation time of 0.5 seconds.

(E) Declared data according to the certification programme LCP EUROVENT



> JOLLY Plus 2

CROSS FLOW FAN WITH BRUSHLESS MOTOR



Upgrade of the Jolly cross-flow fan coil unit series with the introduction of high-efficiency brushless motors. Featuring a maximum depth of 131 mm and in the version with a attractively designed casing, they are suitable for residential heating and air conditioning applications. Available in three versions, VM-F with inlet section automatic casing opening, VM-G with fixed inlet grille and casing and VN without casing for built-in applications, in four sizes with cooling capacity from 0.83 kW to 3.34kW

Unit specifications

Fan coil unit with cabinet with front inlet VM-F, VM-G or built-in version VN.

The fan coil unit is a terminal for room air conditioning in the summer season (coil with cold water) and winter (coil with hot water).

These very compact units are suitable for indoor installations and are amply configurable to meet the needs of highly qualified designers.

The careful design of the main components, refined styling and versatility make them suitable for any type of installation in the residential, commercial or industrial context. Installation therefore only requires the electrical and plumbing connections.

Construction characteristics

■ **SUPPORTING STRUCTURE:** in galvanised sheet of suitable thickness, integrating structural and functional elements in plastic, such as the condensate tray and fan volute. The back has slots for fixing the unit.

■ **HEAT EXCHANGE COIL:** copper tube arranged in staggered rows to increase the heat exchange and aluminium fins with 2 rows, secured by mechanical expansion of the tubes. The manifolds have air vents and water drain holes; the coil has a pocket for the water temperature probe. The connections are located in the left side (facing the unit). Possibility of rotating the coil.

■ **CONDENSATE TRAY:** in thermoplastic material to avoid corrosion, for version VM-G and VN it enables either vertical and horizontal installation of the unit, whereas version VM-F comes with the accessory. The drain hole is on both sides.

■ **FAN MOTOR:** the motor is a high-efficiency brushless type with Hall cell for controlling the speed. It is fitted on rubber mountings to reduce the transmission of noise to the frame. The adjustment enables continuous control of the speed by means of phase cut. With the use of an accessory it is possible to discretise the speeds and make them fixed to then be controlled by standard temperature controllers.

■ **TANGENTIAL FAN:** the tangential-type fan is coupled directly to the motor and mounted on a support in sintered material, which is enclosed in a vibration-damping support.

■ **AIR FILTER:** in polypropylene honeycomb, it is easily removed and can be regenerated simply by washing with water.

■ **CABINET** (only VM-F and VM-G): entirely in steel sheet, epoxy powder coated to ensure high corrosion resistance. The air diffusion grilles are in the top part. The sides are easily removed to allow easy installation and access to all internal components.

Available in colour RAL 9010.

■ **AIR OUTLET GRILLE** (only VM-F and VM-G): in aluminium painted the same colour as the casing, it can be rotated to

direct the air towards the room or towards the wall.

■ **AIR INLET GRILLE** (version VM-F): in extruded aluminium, it features two thermal actuators that open in parallel with activation of the fan. It includes a microswitch that stops the fan if the grille is removed for normal filter cleaning.

(version VM-G): also in extruded aluminium, it is secured in the inlet section and has fixed vanes. It can be removed for filter cleaning.

■ **PLUMBING CONNECTIONS:** the units are equipped with EUROKONUS 3/4" plumbing connections that allow easy and safe connection.

TECHNICAL DATA

Models		20	40	60	80
Performance					
Total cooling capacity	W	830	1760	2650	3340
Sensible cooling capacity	W	620	1270	1960	2650
Water flow rate	l/h	143	303	456	574
Water pressure loss	kPa	7.2	8.4	22.5	18.6
Heating capacity at 50°C inlet water	kW	1090	2350	3190	4100
Water flow rate (50°C inlet water)	l/h	142	302	453	573
Water pressure loss (50°C inlet water)	KPa	5.7	6.6	16.3	14.0
Heating capacity without fan (50°C)	W	210	247	291	366
Heating capacity at 70°C inlet water ΔT 10	kW	1890	3990	5470	6980
Water flow rate (70°C ΔT 10)	l/h	162	343	471	600
Water pressure loss (70°C ΔT 10)	kPa	6.7	7.6	16.1	14.0
Heating capacity without fan (70°C)	W	322	379	447	563
Hydraulic characteristics					
Coil water content	litres	0.47	0.8	1.13	1.46
Max. operating pressure	bar	10	10	10	10
Plumbing connections	inches	Eurokonus 3/4	Eurokonus 3/4	Eurokonus 3/4	Eurokonus 3/4
Aeraulic data					
Max. air flow	m³/h	162	320	461	576
Air flow at medium speed (AUTO mode)	m³/h	113	252	367	453
Air flow at min. fan speed	m³/h	55	155	248	370
Available max. static pressure	Pa	10	10	13	13
Electrical data					
Power supply voltage	V/ph/Hz	230/1/50	230/1/50	230/1/50	230/1/50
Max. power absorbed	W	12	18	20	26
Max. current absorbed	A	0.11	0.16	0.18	0.26
Power absorbed at min. speed	W	6	12	14	18
Sound level					
Sound pressure at max. air flow	dB(A)	39.4	40.2	42.2	42.5
Sound pressure at medium air flow	dB(A)	33.2	34.1	34.4	35
Sound pressure at min. air flow	dB(A)	24.2	25.3	25.6	26.3
Weight					
Net weight unit VM-F	kg	17	20	23	26
Net weight unit VN	kg	9	12	15	18

DIMENSIONS

Version VM-F and VM-G

Version VN

A		20	40	60	80
VM-F and VM-G	mm	735	935	1135	1335
VN	mm	479	679	879	1079

CONFIGURATION

In addition to the standard products, it is possible to request products configured with different solutions for Controller, Valves and plumbing connections side. The various configuration combinations are described below.

Model	Version	Size	Controller (at least one of the three)	Valves	Connections
JOLLY PLUS	VM-F with casing VM-G with casing and fixed grille VN built-in	20 40 60 80	TC+ Continuous on unit* CC-R+ Remote continuous** K3V+ Arr. fixed speeds	- None VB 2 2-way valve kit VB 3 3-way valve kit	- Left (standard) R Right

* only for unit versions VM-F and VM-G
** for combining with user terminal TCR+

Example

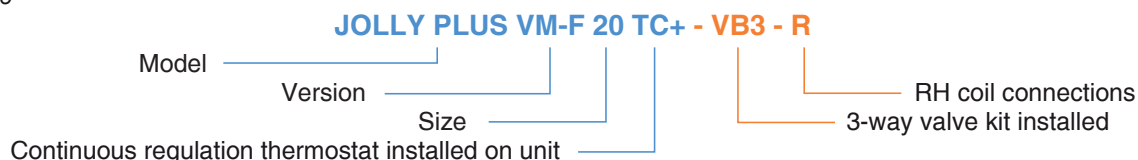

INSTALLATIONS

The following installations are possible depending on the version:

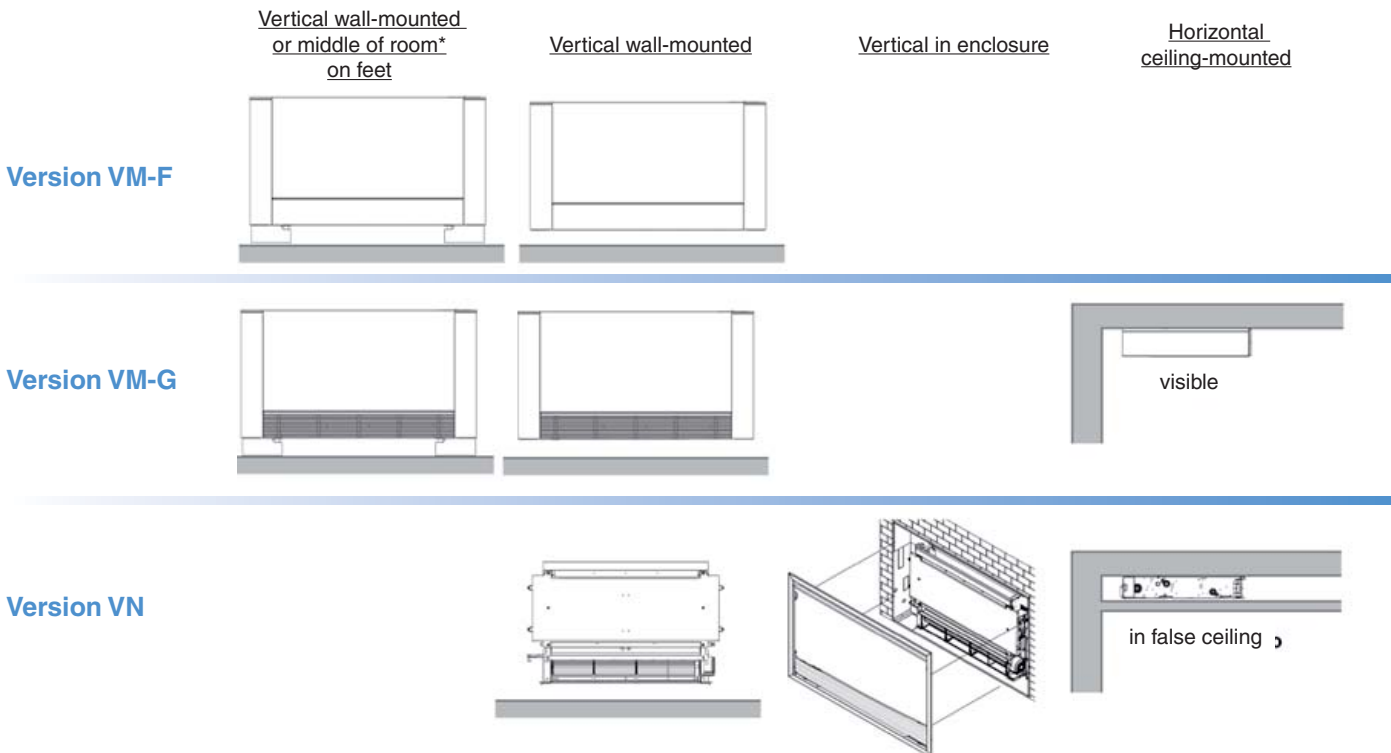

CONTROLS

Range of controls available for the units:

Continuous control series

For best use of the unit's potential, specific controls equipped with continuous regulation algorithms have been developed. This enables a stability of comfort conditions as well as saving linked to modulation of the fan, as well as a positive impact on the noise level of the unit.

They are available in the version on unit, mainly for the version with casing VM-F and VM-G as well as wall-mounting for both versions VM-F, VM-G and VN built-in.

For units with remote terminal, the possibility of connecting up to 31 units able to operate in parallel to a single user terminal has been developed. This solution is suitable for medium large rooms with several units installed.

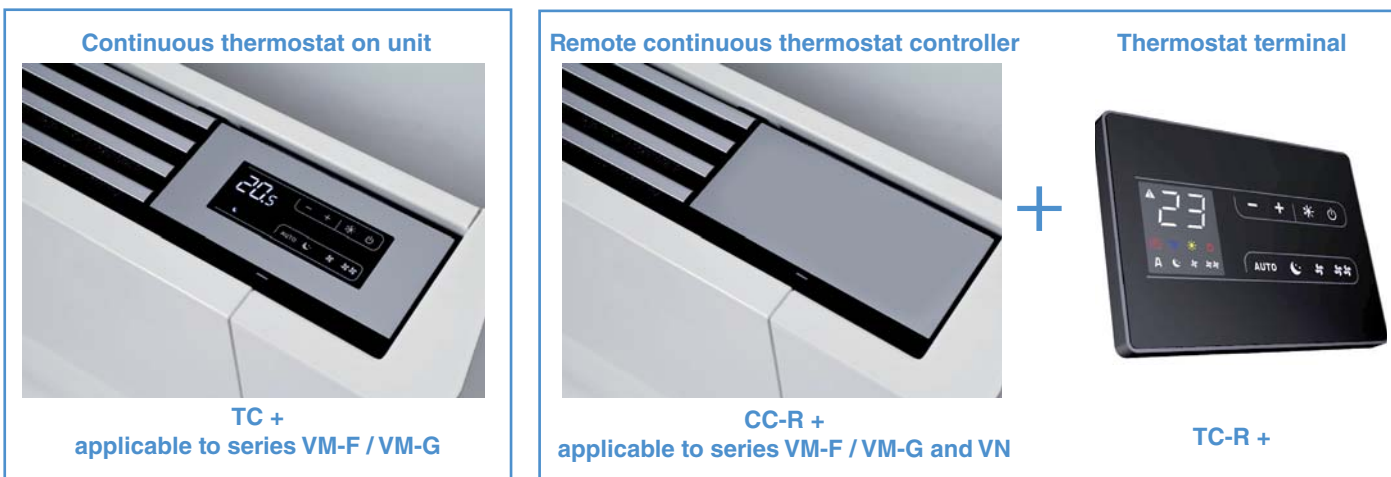

Associated Functions

- Setting of desired temperature
- AUTO fan.
- SILENT mode. (limits max. fan speed)
- NIGHT mode. (limits max. fan speed and changes the set point)
- MAX function (forces max. fan speed)

Other characteristics

- Water temperature sensor for activation in heating and cooling.
- Outputs for control of ON-OFF 230V valves.
- Independent voltage-free contacts, for the control of a chiller and a boiler depending on room request.
- Voltage-free contact (hotel room presence badge or window contact)

Discrete controls

To use controls with three fixed speeds selected from our ranges or those commonly available on the market, it is necessary to use a device to discretise the fan speed. The various room thermostats selected must then be connected to this device.

ACCESSORIES

The unit can be equipped with a wide range of accessories designed for various Installation - Plumbing - Room control purposes. The table below gives the possible combinations. Some of these accessories can be assembled during production according to that given in the configured products table.

Others are to be applied during installation.

VERSION VM-F / VM-G

	Abbrev.	Description	20	40	60	80
For installation	PC 20	Rear closure model VM-F 20	•			
	PC 40	Rear closure model VM-F 40		•		
	PC 60	Rear closure model VM-F 60			•	
	PC 80	Rear closure model VM-F 80				•
	PE	Aesthetic feet	•	•	•	•
	PA	Support feet	•	•	•	•
Controls	TC+	Continuous thermostat on unit	•	•	•	•

VERSION VM-F / VM-G

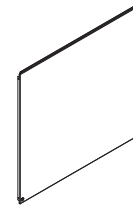

Aesthetic back

VERSION VN

	Abbrev.	Description	20	40	60	80
For installation	RA 20	Inlet union model VN 20	•			
	RA 40	Inlet union model VN 40		•		
	RA 60	Inlet union model VN 60			•	
	RA 80	Inlet union model VN 80				•
	PMT 20	Telescopic delivery plenum model VN 20	•			
	PMT 40	Telescopic delivery plenum model VN 40		•		
	PMT 60	Telescopic delivery plenum model VN 60			•	
	PMT 80	Telescopic delivery plenum model VN 80				•
	PMP 20	Perpendicular delivery plenum model VN 20	•			
	PMP 40	Perpendicular delivery plenum model VN 40		•		
	PMP 60	Perpendicular delivery plenum model VN 60			•	
	PMP 80	Perpendicular delivery plenum model VN 80				•
	GM 20	Curved vane outlet grille model VN 20	•			
	GM 40	Curved vane outlet grille model VN 40		•		
	GM 60	Curved vane outlet grille model VN 60			•	
	GM 80	Curved vane outlet grille model VN 80				•
	GA 20	Curved vane inlet grille model VN 20	•			
	GA 40	Curved vane inlet grille model VN 40		•		
	GA 60	Curved vane inlet grille model VN 60			•	
	GA 80	Curved vane inlet grille model VN 80				•
CF 20	VentilCassaforma model VN 20	•				
CF 40	VentilCassaforma model VN 40		•			
CF 60	VentilCassaforma model VN 60			•		
CF 80	VentilCassaforma model VN 80				•	
PCF 20	Aesthetic panel model VN 20	•				
PCF 40	Aesthetic panel model VN 40		•			
PCF 60	Aesthetic panel model VN 60			•		
PCF 80	Aesthetic panel model VN 80				•	

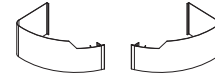

Aesthetic feet

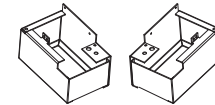

Aesthetic feet for fixing

VERSION VN

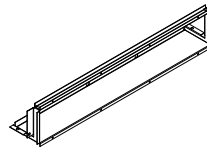

Air inlet union

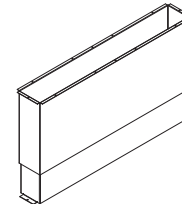

Telescopic delivery duct

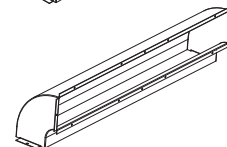

90° curved duct

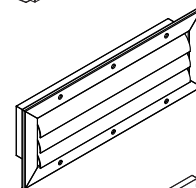

Air inlet grille / Delivery outlet

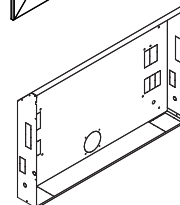

Enclosure for built-in installation

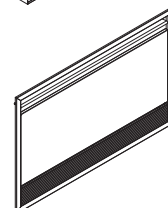

Aesthetic panel

COMMON

	Abbrev.	Description	20	40	60	80
Valves	VB 2	2-way valve kit	•	•	•	•
	VB 3	3-way valve kit	•	•	•	•
Controls	CC-R+	Remote continuous thermostat controller	•	•	•	•
	TC-R+	Remote continuous thermostat terminal	•	•	•	•
	K3V	3-speed kit	•	•	•	•
	TA-3R	Remote 3V analogue terminal	•	•	•	•
	TD-3R	Remote 3V digital terminal	•	•	•	•
Connections	KLR	Plumbing connections conversion kit	•	•	•	•

VALVES

2-way valve



3-way valve

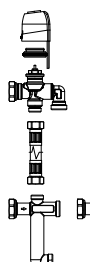

Continuous thermostat on unit



TC+

CONTROLS

Remote continuous thermostat controller



CC-R+

Unit Thermostat



TC-R+

> SUPER FAN

Wall type fan coil



UNIT DESCRIPTION

The wall type fan coil unit is a terminal for the treatment of room air in the summer season (coil supplied with cold water) and in winter (coil supplied with hot water).

These units are suitable for indoor installation, very compact and simply configurable to meet the requirements of highly qualified designers.

The careful design of the main components, refined styling and the versatility of the product make it suitable for any type of installation in the residential, commercial or industrial context. Available in 4 constructional sizes with **1,24 to 3,74 kW** refrigerating power rating and **1,58 to 4,77 kW** heating capacity, they are suitable for installation on walls, while their small size provides them with a pleasant appearance.

The cabinet is made of **ABS** material and provides high mechanical characteristics and resistance to ageing.

It also acts as the bearing structure of the unit.

The ventilating unit consists of a cross-flow fan with an **DC** brushless motor with very low power consumption

A display on the front panel shows the operating status of the units and the setting temperature.

The units are equipped with a pair of flexible hydraulic pipes to facilitate

EC motor



connections to the system.

All the units are equipped with a three-way on-off valve. The valve is installed inside the unit and can be easily accessed via the front panel: use of the three-way valve prevents the unit from cooling too much when the fan is at a standstill and also prevents the unpleasant formation of condensation on the casing

3-way valve



of the machine.

The units can be connect in **Master-Slave** mode.

Master-Slave system



CONTROLS

Two different control are available. One of them must be choose. In case of Master Slave function it will be necessary select at least one control for all the group or zone.

Infrared remote control Rem-I

It set all the function of the units via infrared. It's complete with LCD display, for quick setting of parameters necessary for correct use of the unit.

It's also provided of a wall fixing holder. It permit to control the units from max 7 m distance.



Wire wall control Rem-I

It set all the function of the units via infrared and it can locally measure the ambient temperature. If used in a Master Slave system it can control singularly any units of the system. It can be use as infrared receiver. It's equipped with a 7m connecting wire.



TECHNICAL DATA

MODEL		UM	15	25	35	45	
Power supply		V-F-Hz	230-1-50				
Air flow rate	max.	[m³/h]	370	500	645	880	
	med.	[m³/h]	290	370	500	740	
	min.	[m³/h]	220	290	370	570	
N° fans		N°	1	1	1	1	
Absorption	max. (E)	[W]	13	18	22	30	
	med. (E)	[W]	10	13	15	20	
	min. (E)	[W]	6	10	10	13	
Apparent power		max.	[W]	22	41	52	94
Motor absorption		max.	[A]	0,10	0,19	0,24	0,44
Coil water content			[l]	0,26	0,38	0,72	0,93
Sound power	max. (E)	[dB(A)]	42	48	54	58	
	med. (E)	[dB(A)]	38	40	43	53	
	min. (E)	[dB(A)]	33	35	40	46	
Sound pressure (7)	max.	[dB(A)]	32	38	44	48	
	med.	[dB(A)]	28	30	33	43	
	min.	[dB(A)]	23	25	30	36	
Plumbing connections		F	["]	1/2" F	1/2" F	1/2" F	1/2" F
Condensate drain connection			[mm]	16	16	16	16
Valve		Tipo Connessione	["]	1/2"	1/2"	1/2"	1/2"
				3 vie ON-OFF			
Heating capacity (1)	max.	[W]	2606	4355	6351	7868	
	med.	[W]	2175	3440	5190	6860	
	min.	[W]	1740	2845	3880	5550	
Water flow rate(1)		max.	[l/h]	224	375	546	677
Water pressure drop on water side(1)		max.	[Kpa]	18,1	22,0	34,0	44,1
Heating capacity (2)	max.	[W]	1480	2640	3850	4770	
	med.	[W]	1230	2080	3140	4170	
	min.	[W]	990	1720	2340	3370	
Water flow rate(2)		max.	[l/h]	170	356	521	643
Water pressure drop on water side(2)		max.	[Kpa]	18,4	22,4	35,0	45,0
Potenza termica (3)		max.(E)	[W]	1190	2230	3250	4060
		med.(E)	[W]	1050	1760	2650	3860
		min. (E)	[W]	840	1450	2070	3120
Water flow rate (3)		max.	[l/h]	205	384	559	698
Water pressure drop on water side (3)		max.(E)	[Kpa]	18,4	29,4	38,9	51,5
Total cooling capacity (4)	max.(E)	[W]	990	2050	3010	3710	
	med.(E)	[W]	830	1630	2470	3260	
	min. (E)	[W]	670	1360	1860	2660	
Sensible cooling capacity (4)	max.(E)	[W]	850	1520	2220	2740	
	med.(E)	[W]	710	1200	1810	2400	
	min.(E)	[W]	570	995	1350	1940	
Dehumidification at maximum speed (4)			[g/h]	400	700	1050	1330
Water flow rate (4)			[l/h]	170	353	518	638
Water pressure drop on water side (4)		max.(E)	[Kpa]	22,8	28,8	38,5	50
Total cooling capacity(5)	max.	[W]	690	1430	2100	2620	
	med.	[W]	585	1130	1750	2320	
	min.	[W]	475	960	1320	1900	
Sensible cooling capacity (5)	max.	[W]	570	1180	1750	2160	
	med.	[W]	495	970	1490	1940	
	min.	[W]	396	770	1130	1610	
Water flow rate(5)		max.	[l/h]	119	246	361	451
Water pressure drop on water side(5)		max.	[Kpa]	11,2	14,4	19,5	25,7
Total cooling capacity (6)	max.	[W]	860	1790	2630	3240	
	med.	[W]	720	1410	2150	2840	
	min.	[W]	580	1190	1620	2320	
Sensible cooling capacity (6)	max.	[W]	640	1330	1970	2400	
	med.	[W]	545	1080	1630	2130	
	min.	[W]	430	870	1220	1740	
Water flow rate(6)		max.	[l/h]	148	308	451	556
Water pressure drop on water side(6)		max.	[Kpa]	17	22,1	29,6	38,4

NOTE:

- (1) Air T=20°C D.B., water IN/OUT 70°/60°C, Max air flow; For medium and low fan speed, water flow as in maximum fan speed mode.
- (2) Air T=20°C D.B. , water inlet temperature 50°C , water flow as in cooling mode. Max air flow
- (3) Air T=20°C D.B., water IN/OUT 45°/40°C, Max air flow.

- (4) Air T=27°C D.B. / 19°C W.B. , Water IN/OUT 7°/12°C, Max air flow
- (5) Air T=27°C D.B. / 19°C W.B. , Water IN/OUT 10°/15°C, Max air flow
- (6) Air T=25°C D.B. / 17,9°C W.B. , Water IN/OUT 7°/12°C, Max air flow.
- (7) Sound pressure level in 100m2 room with 0.5sec of reverberation time
- (E): EUROVENT certified data

OVERALL DIMENSIONS

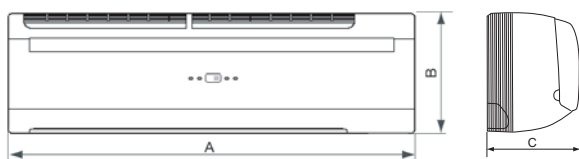

MOD.	15	25	35	45	UM
A		876			mm
B		300			mm
C		228			mm
Weigh	11	12	13	14	kg

> FCM

FAN COIL CASSETTE



EUROVENT CERTIFICATION IN PROGRESS

General specification

- 2 versions – for 2 pipes plant and for 4 pipes plant.
- 4 model available for 2 pipes type and 2 model for 4 pipes type.
- New EC motor with low consumptions up to 30% respect to a standard motor.
- Controlled by infrared remote controller (standard) and a wired controller (optional)
- Timer setting.
- Available function : Heating, Cooling, Dehumidification, Automatic.

Standard accessories

These units are equipped with drain pump. The height of the drainpipe shall set no more than 750mm (500mm for 400 and 400-4 model), otherwise, it's necessary to introduce an auxiliary water pump.

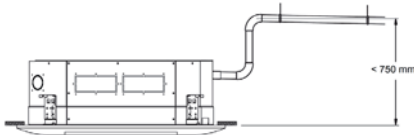

Controller:

■ INFRARED REMOTE CONTROLLER (Standard)

This controller is very easy to use and all parameters are under control. The limit transmitting distance of this remote controller is 10m.

■ WIRED CONTROLLER (Optional)

This controller is very easy to use and all parameters are under control. In this case, the panel is fixed to the wall and connected to the unit by a wire.



Optional accessories

The following accessories are available for this category:

■ 3-WAY VALVE KIT (obligatory for operation in the cooling mode)

The three-way valve is not only required to control the ambient temperature, but also to block the flow of chilled water to the coil if the level of condensed water in the tray should rise in an abnormal way.

It is obligatory to install this valve if the unit is used for operation in the cooling mode during summer as this stops it from cooling too much during the periods when the fan remains at a standstill, thus preventing the unpleasant formation of condensation on the casing of the machine.

The kit include copper pipe connections and 3-way valve with ON/OFF electrothermic actuator, suitable for 230V power input. The valve is controlled by main board of the unit.

■ DRIP TRAY

This PVC tray gather and conduct outside condensation on pipe connections and 3-way valve kit (if present).

OPTION INSTALLATION

Fresh air flow input

For fresh air flow input there is a pre-cut hole to connect the unit to a circular duct. It is possible to control fresh air flow by an external fan (not included). This fan can be controlled by main board of the unit.

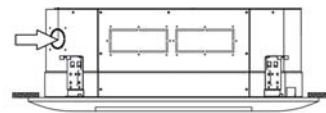

4 pipes model	400-4	750-4	U.M.
2 pipes model	400	600 850 1500	-
Ø	65	75	mm

Air delivery into an adjacent room

On all sides there are pre-cut hole to connect the unit to adjacent rooms by some ducts.

4 pipes model	2 pipes model	A	B	Ø	U.M
400-4	400	/	/	150	mm
-	600	75	160	/	mm
750-4	850 1500	95	160	/	mm

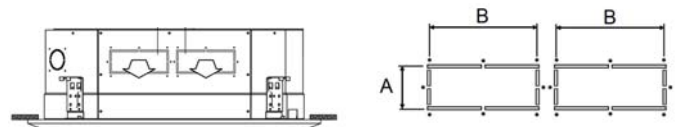

MODELS		400	600	850	1500	400-4	750-4	U.M
Version		2 pipes				4 pipes		\
Power supply		230-1-50						V-f-Hz
Air Flow	Max	717	1133	1441	1850	717	1233	m³/h
	Med	502	793	1009	1295	502	863	m³/h
	Min	359	567	721	925	359	617	m³/h
Cooling capacity (1)	Max	3930	5580	6840	10640	2880	5180	W
	Med	3070	4350	5330	8090	2190	3940	W
	Min	2480	3520	4300	6600	1800	3260	W
Water flow		676	960	1176	1830	495	891	l/h
Cooling water pressure drop		12	21	27	34	14,5	12	kPa
Heating Capacity (2)	Max	5340	7720	9370	14380	\	\	W
	Med	4000	5920	7250	11290	\	\	W
	Min	3150	4500	5500	8440	\	\	W
Heating Capacity (3)	Max	\	\	\	\	4730	7410	W
	Med	\	\	\	\	3600	5640	W
	Min	\	\	\	\	2980	4670	W
Water flow (2)		676	960	1176	1830	\	\	m³/h
Water flow (3)		\	\	\	\	407	637	m³/h
Heating water pressure drop		10,6	22	23	34	29,1	42	kPa
Power input		27	42	70	124	27	50	W
Sound pressure level	Max	40	42	46	50	40	42	dB(A)
	Med	36	33	36	40	36	34	dB(A)
	Min	28	26	28	33	28	26	dB(A)
Pipe connection		3/4"	3/4"	3/4"	3/4"	3/4"	3/4"	"
Pipe connection auxiliary		\	\	\	\	1/2"	1/2"	"
Net \ Gross weight Body		16.5/21.5	23/28	27/33	29/34.5	17/23	28/34	Kg
Net \ Gross weight Panel		2.5/4.5	6/9	6/9	6/9	2.5/4.5	6/9	Kg
Packing Body dimension	L	655	900	900	900	655	900	mm
	A	290	260	330	330	290	330	mm
	P	655	900	900	900	655	900	mm
Packing Panel dimension	L	715	1035	1035	1035	715	1035	mm
	A	123	90	90	90	123	90	mm
	P	715	1035	1035	1035	715	1035	mm

NOTE:

- (1) Air T=27°C D.B. / 19°C W.B. , Water IN/OUT 7°/12°C, design air flow; For medium and low fan speed, water flow as in maximum fan speed mode.
- (2) Air T=20°C D.B. , water inlet temperature 50°C , water flow as in cooling mode.
- (3) Air T=20°C D.B., water IN/OUT 70°/60°C, design air flow; For medium and low fan speed, water flow as in maximum fan speed mode.
- (4) Sound pressure level in 100m2 room with 0.5sec of reverberation time

DIMENSION

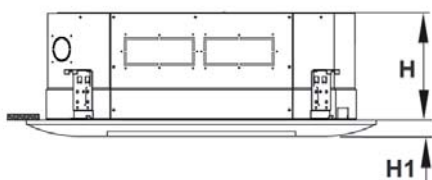
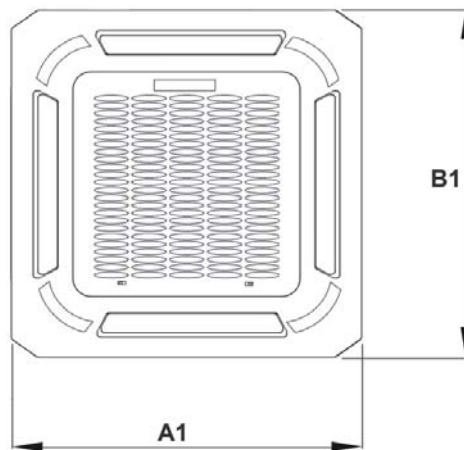
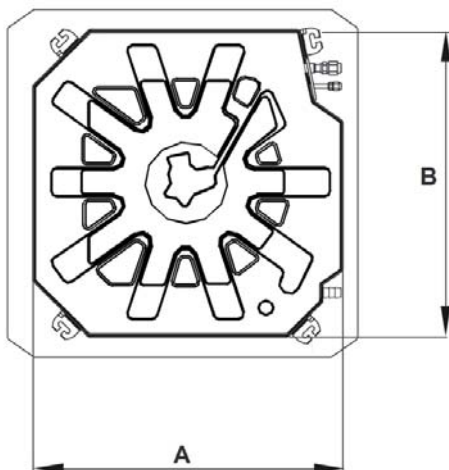

4 pipes model		400-4	-	750-4	UM
2 pipes model		400	600	850 1500	-
Body	A	575	840	840	mm
	B	575	840	840	mm
	H	260	230	300	mm
Panel	A1	647		950	mm
	B1	647		950	mm
	H1	50		45	mm

> MERCURY ST

DUCTED FAN COIL



Fully recirculated ventilation unit designed for operation with up to 10% outdoor air

Units Series

Unit type

MERCURY ST ducted fan coil

MERCURY ST E ducted fan coil with EC fans

Unit specification

- Horizontal or vertical installation
- Structure and panels made by Aluzink sheet metal thermal and acoustic insulated
- Synthetic filters G3
- Water heat exchanger to 3 or 4 ranks (optional 6 ranghi) with copper pipes and aluminum fins, fitted with internal drip tray in stainless steel
- Centrifugal fans directly coupled to electric motor (standard 3 speeds for MERCURY ST, brushless EC type MERCURY ST E)
- Electrical box on board

Accessories

- Oversized internal coil **6R** (only horizontal models)
- Intake grille - **GAS**
- Intake plenum - **PAS**
- Filtering section - **AF**
- Mixing section - **CM**
- Water post-heating section - **SRW**
- Electric post-heating section - **SRE I 2SRE**
- Sound proofed outlet plenum - **PAM**
- Outlet plenum for flexible ducts - **PBC**
- Outlet flange for connection to the ducts - **FM**
- Outlet with adjustable fins - **BRM**

Controller

For wall remote installation

- Speed controller - **COM3**
- Unit control panel - **PCU**
- Unit control panel with EC fans - **EC - PCUE**
- Unit control panel with SRE / 2SRE - **PC+PE**
- Unit control panel with 0-10V - **PC10R**

Technical data

MODEL	05	05 E	07	07 E	11	11 E	13	13 E	17	17 E	19	19 E	21	21 E	UM
Nominal air flow rate	900		1500		1600		2100		2400		3600		4200		m ³ /h
External static pressure / ESP ⁽¹⁾	95	95	100	100	85	80	110	125	105	110	120	90	115	100	Pa
Sound static pressure ⁽¹⁾	50		51		52		55		55		58		58		dB (A)
Electrical data	05	05 E	07	07 E	11	11 E	13	13 E	17	17 E	19	19 E	21	21 E	UM
Power supply							230 / 1 / 50							V/ph/Hz	
Max power input ⁽¹⁾	0.23	0.15	0.31	0.25	0.29	0.25	0.44	0.47	0.45	0.47	0.77	0.61	0.99	0.80	kW
Max current input ⁽¹⁾	1.1	1.2	1.5	2.0	1.5	2.0	2.0	3.7	2.1	3.7	4.0	2.7	5.1	3.5	A
Fans	05	05 E	07	07 E	11	11 E	13	13 E	17	17 E	19	19 E	21	21 E	UM
Type motor	AC	EC	AC	EC	AC	EC	AC	EC	AC	EC	AC	EC	AC	EC	-
N° speed ⁽²⁾	3	Multiple	3	Multiple	3	Multiple	3	Multiple	3	Multiple	3	Multiple	3	Multiple	-
Control fans ⁽²⁾	Man	0-10V	Man	0-10V	Man	0-10V	Man	0-10V	Man	0-10V	Man	0-10V	Man	0-10V	-
Standard coils	05	07	11	13	17	19	21	UM							
Total cooling capacity ⁽³⁾	4.6	7.5	9.1	10.5	13.1	15.7	20.7	kW							
Heating capacity ⁽⁴⁾	9.8	15.5	19.7	21.6	25.9	35.5	46.0	kW							
Water connections	G 3/4	G 3/4	G 3/4	G 3/4	G 3/4	G 1	G 1	"							
6 rows coils	05	07	11	13	17	19	21	UM							
Potenza frigorifera totale ⁽³⁾	6.2	10.7	11.2	14.3	17.5	24.1	26.8	kW							
Heating capacity ⁽⁴⁾	12.6	20.8	21.5	27.5	32.9	47.4	52.0	kW							
Water connections	G 3/4	G 3/4	G 3/4	G 3/4	G 3/4	G 1	G 1	"							
Post-heating coil. 2 rows	05	07	11	13	17	19	21	UM							
Heating capacity ⁽⁴⁾	6.8	10.9	11.5	13.5	16.0	20.3	22.2	kW							
Water connections	G 3/4	G 3/4	G 3/4	G 3/4	G 3/4	G 3/4	G 3/4	"							

(1): At top speed, with standard battery; Data referred to 1,5 m from inlet machine in free at nominal air flow-rate.

(2): Multiple = Multispeed > 3; Man = Manual from selector or keyboard; 0-10V = From potentiometer or keyboard.

(3): Inlet air temperature 27°C 47% UR, inlet/outlet water temperature 7/12°C

(4): Inlet air temperature 20°C, inlet/outlet water temperature 70/60°C

NOTE: Available on high-head version required.

DIMENSIONS

(drawing indicative of the series)

Horizontal models

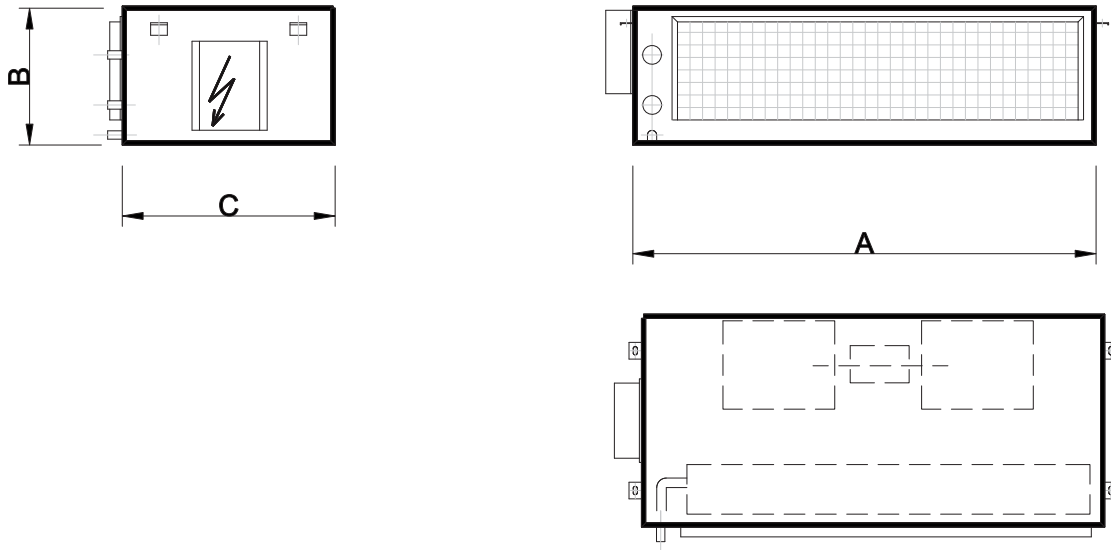

MODEL	05	07	11	13	17	19	21	UM
A	645	1000	1100	1100	1345	1345	1345	mm
B	296	296	325	325	325	375	375	mm
C	520	520	600	600	600	600	600	mm
Weight	24	34	37	41	47	55	60	kg

Vertical models

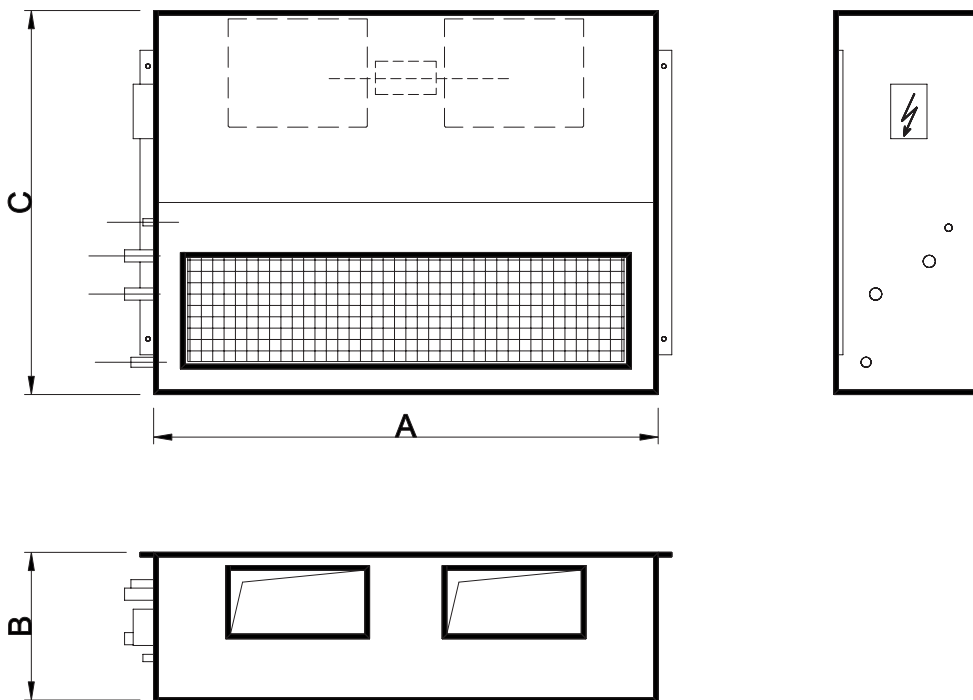

MODEL	05	07	11	13	17	19	21	UM
A	645	1000	1100	1100	1345	1345	1345	mm
B	296	296	325	325	325	375	375	mm
C	750	750	835	835	950	950	950	mm
Weight	30	45	48	54	63	72	75	kg

> FAHU

AIR HANDLING UNITS

The **FAHU series is Eurovent certified** and is built with a modular system providing for 29 sizes for a wide range of capacities with the possibility of special set-up upon request.

■ **STRUCTURE:** made with strong framework in extruded anodised aluminium sections, joined with angle joints in die-cast aluminium panels with double shell made by galvanised steel sheet, prepainted, stainless ASI 304 or peraluman.

The panels are available in 2 different thickness:

- 48 mm with polyurethane foam
- 48 mm with high density rock wool
- 63 mm only with high density rock wool, coupled to special extruded anodised aluminium sections with rounded edges complete with thermal break to minimize heat loss and air leakage. In this configuration, panels and profiles are coplanar thus making the surface of the central completely smooth, thus facilitating the operations of cleaning and sanitizing.

This solution is particularly suitable for applications in hospitals, food processing, pharmaceutical, etc.

The panels are equipped with self-adhesive type seals. The inspection panels are fitted on hinges and provided with double closing handles (internal and external).

The fixed panels 48 mm thickness are fasten to the frame with galvanised steel or stainless steel screws.

The fixed panels 63 mm thickness are fasten to the frame with galvanised steel or stainless steel screws that are completely surrounded by the thermal insulation so avoiding any possible thermal bridge.



Ferrol participates to the Eurovent certification program referred to the Air Handling Units (AHU). The Eurovent certification program is based on the requirements defined by the EN 1886 standard that ranks the following technical features of air-handling units:

- Mechanical strength of the casing
- Air leakage through the casing
- Air leakage around the filter frame
- Thermal transmittance of the casing
- Thermal bridges of the casing
- Acoustic insulation of the casing



The verification of these requirements is based on tests conducted by TUV laboratory accredited by Eurovent.

> FTP

AIR HANDLING UNITS

The **FTP series** is built with a modular system providing for 29 sizes for a wide range of capacities with the possibility of special set-up upon request.

■ **STRUCTURE:** made with strong framework in extruded anodised aluminium sections, joined with angle joints in die-cast aluminium or nylon panels with double shell and insulated with high density rock wool or polyurethane foam with thickness 23, 48 or 63 mm, with normal profiles or with thermal break. The panels can be made by:

- galvanised steel sheet
- prepainted steel sheet
- peraluman sheet
- AISI 304 stainless steel sheet

The panels are fixed to the frame with galvanised steel or stainless steel screws and are equipped with self-adhesive type seals. The inspection panels are fitted on hinges and provided with double closing handles (internal and external).



> General features

- **BASE:** With a continuous beam in heavy galvanised steel sheet, press bent with sections with a high structural rigidity which ensure safe transport and handling on site.



- **FANS:** to be selected upon the specific application:
 - Dual-intake centrifugal type with forward or backward blades
 - Dual-intake centrifugal type with airfoil backward blades
 - Plug fan with speed control via 0-10V signal. They can be supplied with standard AC motor and external inverter control or with brushless EC motor ("inverter" built-in motor)



- **MOTORS:** brushless type (for EC plug fan) or three-phase asynchronous squirrel-cage rotor windings and class F. All motors have efficiency class IE2 (IE3 on request) according to the international standard IEC 60034-30 and the ErP Directive 2009/125/EC (formerly EuP).

- **HEAT EXCHANGER COILS,** removable type, can be chosen to work with water, brine solutions (eg. Glycol), steam or direct expansion. In the standard version are made with aluminum fins and copper pipes mechanically expanded. On request can be supplied in special versions (steel pipes or stainless steel, pre-painted aluminium fins, copper fins, etc..).



- **ELECTRIC COILS:** The electric coils have armored-type heaters with one or two stages, complete with electrical panel and safety thermostat.

- **AIR FILTERS** with high surface area and low pressure drop, can be selected:
 - Roll filters
 - Rigid or soft pockets filters
 - Corrugated filter cells
 - Activated carbon filters



- **HEAT RECOVERY** can be selected:
 - Static type cross-flow plates made of aluminum (or steel) sealed so as to ensure the total absence of contact between the exhaust air and the fresh air entered.
 - Rotary with rotating hygroscopic drum; on demand can be supplied complete with a device for controlling the speed of rotation.



- **DAMPERS:** constructed of galvanized sheet metal frame and paneled extruded aluminum fins, complete with gasket for maximum sealing.

- **HUMIDIFICATION** to be selected according to the specific application:
 - **STEAM** through the installation of a steam generator or through distributors in case of steam network.
 - by **NOZZLES** through self-cleaning spray nozzles, mounted on one or two trains.
 - **PACK** by a honeycomb packing cellulose impregnated with phenolic resins, complete with metal frame containing and water distributor.

- **COLLECTION TRAYS:** These can be in galvanised steel or AISI 304 stainless steel sheet, provided with drain manifold.

- **SILENCERS** available in different lengths, are made with insulating baffles, constructed with multiple layers of rock wool content from a microperforated sheet metal; external surfaces of the septa in direct contact with the treated air are coated with a plastic film to prevent flaking.

Software Selection

Ferrolì cta is a selection powerful and versatile software that allows you to select the air handling unit best suited to your specific needs quickly and completely.

The output generated by the SW is offering a comprehensive economic, including technical drawings and characteristics of the selected components.

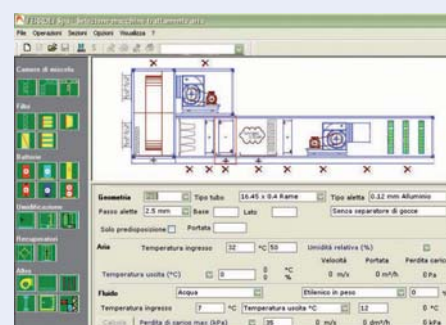

> UT REC micro E

HEAT RECOVERY UNITS



Unit specification

- Air-to-air enthalpy heat recovery device, thermal efficiency up to 76%
- Galvanized steel self-supporting panels, internally and externally insulated; accessibility from side door
- F9 efficiency class filter with synthetic cleanable media and G3 pre-filter on fresh air, G3 filter on return air intake
- Integrated pressure switch for dirty filter signal
- Motorised heat recovery by-pass device, automatically controlled by unit control to use fresh air free-cooling when convenient
- Low consumption high efficiency & low noise direct driven fans with 10-speed EC motors
- Duct connections by circular plastic collars
- Built-in electric box equipped with PCB to control fan and by-pass function.

Accessories

- Touch screen controller - **PTS**
- CO₂ wall mount sensor - **QSW**
- Humidity wall mount sensor - **USW**
- Duct circular sound attenuator - **SLC**

Technical data

MODEL	E 25H	E 35H	E 50H	E 65H	E 80H	E 100H	E 130H	UM
Nominal airflow rate	250	350	500	650	800	1000	1300	m ³ /h
Nominal external static pressure	90	140	110	100	140	140	140	Pa
Power supply	230/1/50							V/ph/Hz
Total full load amperage	0.5	0.6	0.6	1.2	1.4	2.1	2.7	A
Fans	E 25H	E 35H	E 50H	E 65H	E 80H	E 100H	E 130H	UM
Motor typology	EC	EC	EC	EC	EC	EC	EC	-
Number of speeds	10	10	10	10	10	10	10	-
Fan control ⁽¹⁾	Man	Man	Man	Man	Man	Man	Man	-
Internal specific fan power of ventilation components - SFP int	812	670	547	846	865	881	873	W (m ³ /s)
Total nominal power input	0.08	0.13	0.15	0.23	0.32	0.39	0.50	kW
Sound pressure level ⁽²⁾	34	37	39	40	42	43	44	dB(A)
Heat exchanger	E 25H	E 35H	E 50H	E 65H	E 80H	E 100H	E 130H	UM
Winter thermal effic. ⁽³⁾	73.0	74.0	76.0	74.0	76.0	76.0	74.2	%
Winter enthalpy effic. ⁽³⁾	65.0	65.0	67.0	65.0	65.0	62.0	59.0	%
Summer thermal effic. ⁽⁴⁾	73.0	74.0	76.0	74.0	76.0	76.0	74.0	%
Summer enthalpy effic. ⁽⁴⁾	62.0	62.0	63.0	60.0	63.0	60.0	58.0	%
Dry thermal efficiency ⁽⁵⁾	73.0	74.0	76.0	74.0	76.0	76.0	74.0	%

NOTA

(1) Man = Manual by selector switch or control panel

(2) Sound pressure level calculated at 1 m far from a ducted supply-exhaust air/ducted; return-fresh air intake/service side, at nominal conditions.

(3) Outside air at -5 80% RH; room air at 20 C 50% RH

(4) Outside air at 32 50% RH; room air at 26 C 50% RH

(5) Refer to EU 1253/2014 regulation at nominal pressure; air conditions refer to EN 308 standard

DIMENSIONS, WEIGHT

(drawing indicative of the series)

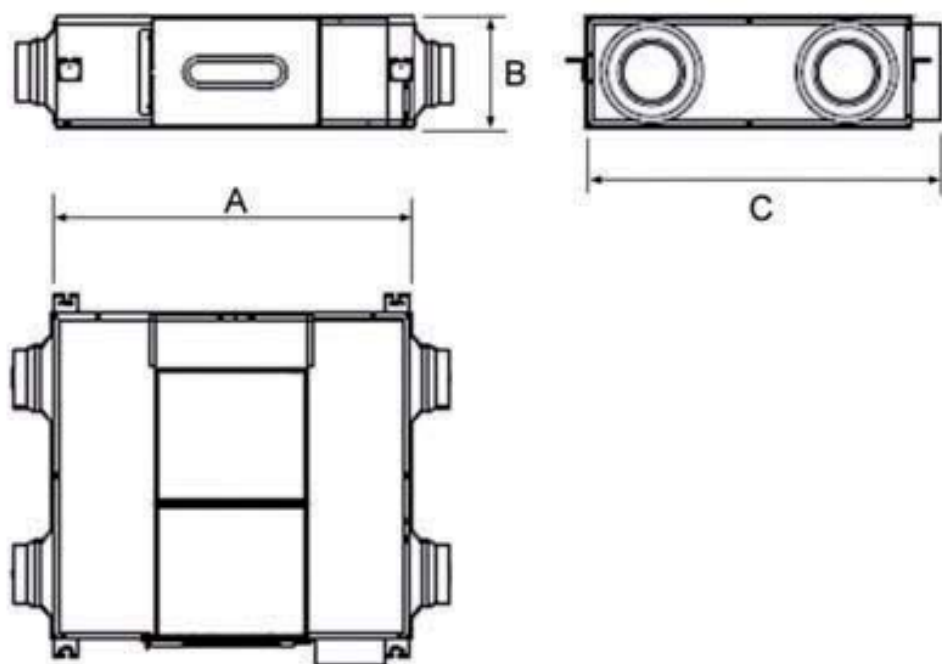

MODEL		E 25H	E 35H	E 50H	E 65H	E 80H	E 100H	E 130H	UM
Dimension	A	815	815	895	1185	1185	1200	1200	mm
	B	270	270	270	390	390	390	390	mm
	C	650	855	955	945	1200	1290	1290	mm
Weight		30	37	43	65	71	83	83	kg

> UT REC +

HEAT RECOVERY UNITS

ERP

Units Series

Version

UT REC+ with recuperator in aluminium and standard fans
 UT REC E+ with recuperator in aluminium and EC fans

Unit specification

- Air-to-air aluminium counterflow heat recovery device, thermal efficiency up to 84%
- Constant air flow fans available on UT REC E+ 100 - 500
- Built in by-pass facility
- Case made by sandwich panels 23 mm thickness, galvanized inner skin and prepainted outer skin ; 45 kg/m³ density foamed polyurethane as heat and sound insulation
- Full-range controlled direct driven double inlet centrifugal fans; low consumption EC technology motors on UT REC E+
- Filtering sections composed by cell filters with polypropylene media, extractable from side removable panels, F7 efficiency for the fresh air flow, M5 efficiency for the exhaust air flow
- Integrated pressure switch for dirty filter signal
- Condensate drain pan made of galvanized steel plate with water drain connection downwards, that ensure a total drainage.



Accessories

- Internal electric post-heating coil - **BER**
- Post-heating internal water coil - **BCR**
- Water cooling or heating coil section - **SBFR**
- High efficiency filters on exhaust air - **F7CF**
- Additional pressure switch - **PF**
- Regulation damper - **SR**
- 3 dampers defrosting section - **RMS**
- Damper actuators - **SM / SMR**
- Kit bypass management - **KBP**
- N. 4 connections for circular ducts kit - **SPC**
- Duct silencers - **SSC**
- Signal lamps kit - **KLS**
- Anti-freeze thermostat - **TA**
- Kit for external installation - **EXT**
- Kit weather hood for external installation - **CPA**
- Unit speed control panel (UT REC+ 40 - 320) - **COM 3**
- Unit control panel - **PCU**
- Unit control panel with EC fans EC - **PCUE**
- Unit control panel with EC fans EC Modbus - **PCUEM**
- Unit control panel out 0-10V - **MCUE**
- Constant air flow fans control (UT REC E+ 100 - 500) - **VSD**
- Integrated management system unit - **SIGB**
- Integrated management system wall mounted - **SIGQ**
- User terminal remote - **TUP**
- Modbus PCB - **SCMB**
- CO₂ sensor duct - **QSC**
- CO₂ sensor wall - **QSA**
- Humidity sensor duct - **USD**
- Humidity sensor wall - **USW**

Technical data

UT-REC +	40	75	100	150	200	320	400	500	UM
Nominal air flow	400	750	1000	1500	2050	3200			m ³ /h
Nominal external static pressure	160	120	130	160	120	180			Pa
Maximum external static pressure	160	120	130	160	120	180			Pa
Power supply	230/1/50				230/1/50-60				V/ph/Hz
Total full load amperage	1.5	2.9	6.0	6.0	6.0	14			A
UT-REC E+	40	75	100	150	200	320	400	500	UM
Nominal air flow	400	750	1000	1500	2050	3200	3800	4700	m ³ /h
Nominal external static pressure	160	120	130	160	120	180	200	200	Pa
Maximum external static pressure	340	210	520	500	540	375	330	200	Pa
Power supply	230/1/50				230/1/50-60				V/ph/Hz
Total full load amperage	2.4	2.4	9.0	9.0	9.0	10	8.8	8.8	A
UT-REC + Fans	40	75	100	150	200	320	400	500	UM
Motor typology	AC	AC	AC	AC	AC	AC			-
Number of speeds ⁽¹⁾	4	3	3	3	3	3			-
Fan control ⁽¹⁾	Man	Man	Man	Man	Man	Man			-
Internal specific fan power of ventilation components - SFP int ⁽⁵⁾	740	934	1105	1102	1078	1054			W/(m ³ s)
Total nominal power input	0.17	0.38	0.52	0.80	1.00	1.79			kW
Sound pressure level ⁽²⁾	59	60	63	63	63	69			dB(A)
UT-REC E+ Fans	40	75	100	150	200	320	400	500	UM
Motor typology	EC	EC	EC	EC	EC	EC	EC	EC	-
Number of speeds ⁽¹⁾	Multiple	Multiple	Multiple	Multiple	Multiple	Multiple	Multiple	Multiple	-
Fan control ⁽¹⁾	0-10V				0-10V VSD				-
Internal specific fan power of ventilation components - SFP int ⁽⁵⁾	705	742	1059	1048	898	1040	949	935	W/(m ³ s)
Total nominal power input	0.16	0.30	0.49	0.76	0.84	1.77	1.78	2.19	kW
Sound pressure level ⁽²⁾	60	61	62	64	62	68	70	73	dB(A)
UT-REC + Heat exchanger	40	75	100	150	200	320	400	500	UM
Winter thermal effic. ⁽³⁾	83.6	82.9	81.6	83.3	83.7	86.8			%
Summer thermal effic. ⁽⁴⁾	75.5	75.9	74.5	75.1	75.6	78.0			%
Dry thermal efficiency ⁽⁵⁾	75.9	76.4	75.0	75.6	76.0	76.3			%
UT-REC E+ Heat exchanger	40	75	100	150	200	320	400	500	UM
Winter thermal effic. ⁽³⁾	83.6	82.9	81.6	83.3	83.7	86.8	84.1	84.2	%
Summer thermal effic. ⁽⁴⁾	75.5	75.9	74.5	75.1	75.6	78.0	75.0	75.1	%
Dry thermal efficiency ⁽⁵⁾	75.9	76.4	75.0	75.6	76.0	76.3	75.5	75.6	%

NOTA

- (1) Multiple = Multispeed > 3 ;
 Man = Manual by selector switch or control panel;
 0-10V = By potentiometer or control panel;
 VSD = Constant flow control or modulation by air quality or air humidity sensor
- (2) Sound pressure level calculated at 1 m far from a ducted supply-exhaust air/ ducted; return-fresh air intake/service side, at nominal conditions.

- (3) Outside air at -5 80% RH; room air at 20 C 50% RH
 (4) Outside air at 32 50% RH; room air at 26 C 50% RH
 (5) Refer to EU 1253/2014 regulation at nominal pressure; air conditions refer to EN 308 standard

DIMENSIONS, WEIGHT

(drawing indicative of the series)

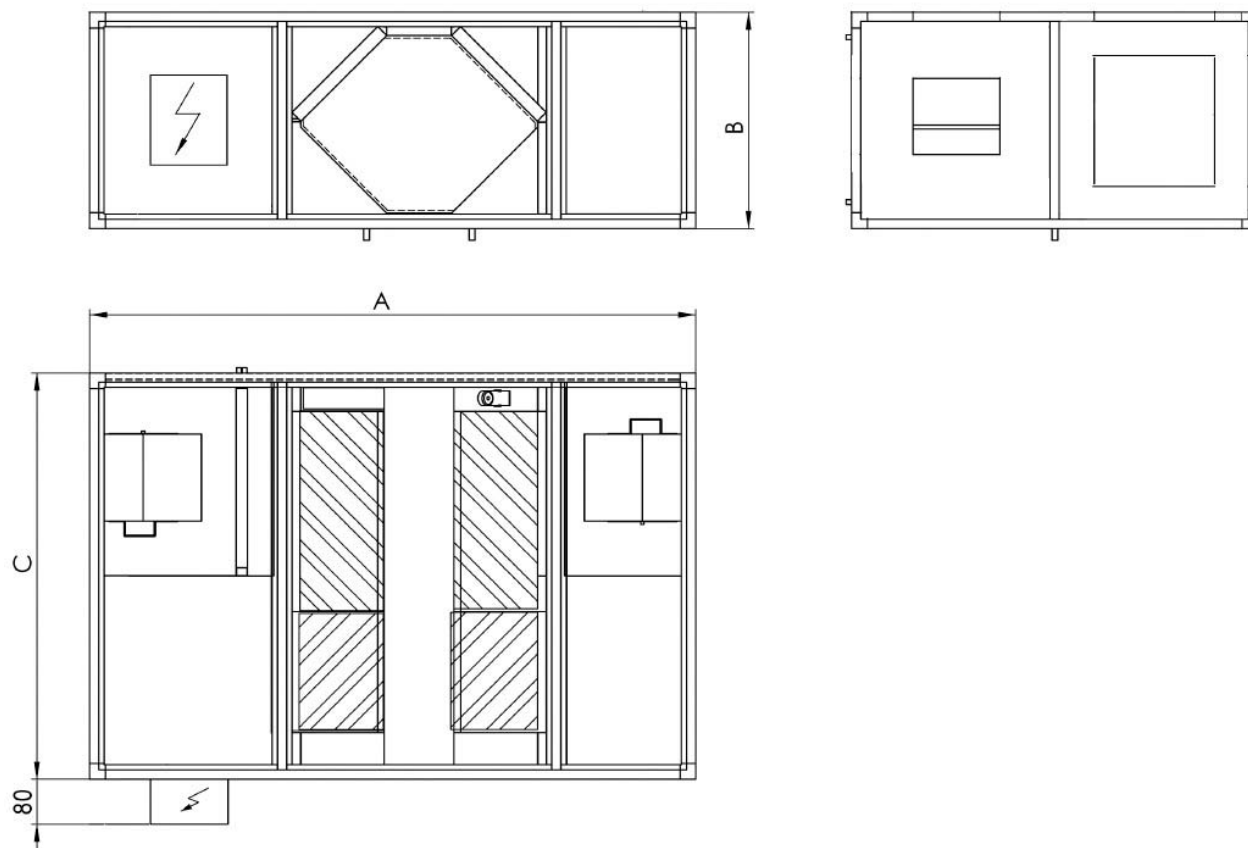

Model		40	75	100	150	200	320	400	500	UM
Dimension	A	1480	1940	1940	2200	2200	2500	2500	2500	mm
	B	380	480	480	550	550	680	680	680	mm
	C	800	990	990	1000	1400	1400	1400	1700	mm
Weight		90	140	150	170	200	240	250	280	kg

> UT REC C+

HEAT RECOVERY UNITS



Units Series

Version

UT REC C+ with paper pack recuperator and standard fans

UT REC CE+ with paper pack recuperator and EC fans

Unit specification

- Air-to-air enthalpy cross-flow heat recovery device, thermal efficiency up to 75%
- Constant air flow fans available on UT REC CE+ 100 - 320
- Ceiling horizontal installation, the heat exchanger is extractable from below for all models
- Case made by sandwich panels 23 mm thickness, galvanized inner skin and prepainted outer skin ; 45 kg/m³ density foamed polyurethane as heat and sound insulation
- Full-range controlled direct driven double inlet centrifugal fans; UT REC CE+ version with low consumption EC technology motors available
- Filtering sections composed by cell filters with polypropylene media, extractable from side removable panels, F7 efficiency for the fresh air flow, M5 efficiency for the exhaust air flow
- Integrated pressure switch for dirty filter signal

Accessories

- Internal electric post-heating coil - **BER**
- Post-heating internal water coil - **BCR**
- Water cooling or heating coil section - **SBFR**
- High efficiency filters on exhaust air - **F7CF**
- Additional pressure switch - **PF**
- Regulation damper - **SR**
- 3 dampers defrosting section - **RMS**
- Damper actuators - **SM / SMR**
- Kit bypass management - **KBP**
- N. 4 connections for circular kit - **SPC**
- Duct silencers - **SSC**
- Signal lamps kit - **KLS**
- Anti-freeze thermostat - **TA**
- Kit for external installation - **EXT**
- Kit weather hood for external installation - **CPA**
- Kit weather hood for external installation (UT REC C+) - **COM 3**
- Unit control panel - **PCU**
- Unit control panel with EC fans EC - **PCUE**
- Unit control panel with EC fans EC Modbus - **PCUEM**
- Unit control panel out 0-10V - **MCUE**
- Constant air flow fans control (UT REC CE+100 - 320) - **VSD**
- Integrated management system unit - **SIGB**
- Integrated management system wall mounted - **SIGQ**
- User terminal remote - **TUP**
- Modbus PCB - **SCMB**
- CO₂ sensor duct - **QSC**
- CO₂ sensor wall - **QSA**
- Humidity sensor duct - **USD**
- Humidity sensor wall - **USW**

Technical data

UT-REC C+	40	75	100	150	200	320	UM
Nominal air flow	400	660	1000	1500	2300	3100	m ³ /h
Nominal external static pressure	170	120	160	190	240	190	Pa
Maximum external static pressure	170	120	160	190	240	190	Pa
Power supply	230/1/50		230/1/50-60				V/ph/Hz
Total full load amperage	1.5	2.9	6.0	6.0	14.0	14.0	A
UT-REC CE+	40	75	100	150	200	320	UM
Nominal air flow	400	660	1000	1500	2300	3100	m ³ /h
Nominal external static pressure	170	120	160	190	240	190	Pa
Maximum external static pressure	375	250	535	550	447	400	Pa
Power supply	230/1/50		230/1/50-60				V/ph/Hz
Total full load amperage	2.4	2.4	9.0	9.0	9.0	10.0	A
UT-REC C+ Fans	40	75	100	150	200	320	UM
Motor typology	AC	AC	AC	AC	AC	AC	-
Number of speeds ⁽¹⁾	4	3	3	3	3	3	-
Fan control ⁽¹⁾	Man	Man	Man	Man	Man	Man	-
Internal specific fan power of ventilation components - SFP int ⁽⁵⁾	549	824	1015	1031	1008	966	W/(m ³ s)
Total nominal power input	0.16	0.28	0.55	0.96	1.55	1.67	kW
Sound pressure level ⁽²⁾	58	59	62	62	62	68	dB(A)
UT-REC CE+ Fans	40	75	100	150	200	320	UM
Motor typology	EC	EC	EC	EC	EC	EC	-
Number of speeds ⁽¹⁾	Multiple	Multiple	Multiple	Multiple	Multiple	Multiple	-
Fan control ⁽¹⁾	0-10V		0-10V VSD				-
Internal specific fan power of ventilation components - SFP int ⁽⁵⁾	535	755	882	673	857	866	W/(m ³ s)
Total nominal power input	0.15	0.26	0.48	0.62	1.31	1.50	kW
Sound pressure level ⁽²⁾	59	60	61	63	61	67	dB(A)
UT-REC C+ Heat exchanger	40	75	100	150	200	320	UM
Winter thermal effc ⁽³⁾	75.0	73.7	74.0	73.0	73.2	71.4	%
Winter enthalpy effc ⁽³⁾	60.0	58.2	58.8	62.5	62.7	55.5	%
Summer thermal effc ⁽⁴⁾	64.1	59.7	60.2	60.1	60.2	57.4	%
Summer enthalpy effc ⁽⁴⁾	56.7	55.1	55.7	58.3	58.5	52.5	%
Dry thermal efficiency ⁽⁵⁾	75.1	73.7	74.2	73.1	73.2	73.0	%
UT-REC CE+ Heat exchanger	40	75	100	150	200	320	UM
Winter thermal effc ⁽³⁾	75.0	73.7	74.0	73.0	73.2	71.4	%
Winter enthalpy effc ⁽³⁾	60.0	58.2	58.8	62.5	62.7	55.5	%
Summer thermal effc ⁽⁴⁾	64.1	59.7	60.2	60.1	60.2	57.4	%
Summer enthalpy effc ⁽⁴⁾	56.7	55.1	55.7	58.3	58.5	52.5	%
Dry thermal efficiency ⁽⁵⁾	75.1	73.7	74.2	73.1	73.2	73.0	%

NOTA

- (1) Multiple = Multispeed > 3 ;
 Man = Manual by selector switch or control panel;
 0-10V = By potentiometer or control panel;
 VSD = Constant flow control or modulation by air quality or air humidity sensor
- (2) Sound pressure level calculated at 1 m far from ducted supply-exhaust air/ ducted; return-fresh air intake/service side, at nominal conditions.

(3) Outside air at -5 80% RH; room air at 20 C 50% RH

(4) Outside air at 32 50% RH; room air at 26 C 50% RH

(5) Refer to EU 1253/2014 regulation at nominal pressure; air conditions refer to EN 308 standard

DIMENSIONS, WEIGHT

(drawing indicative of the series)

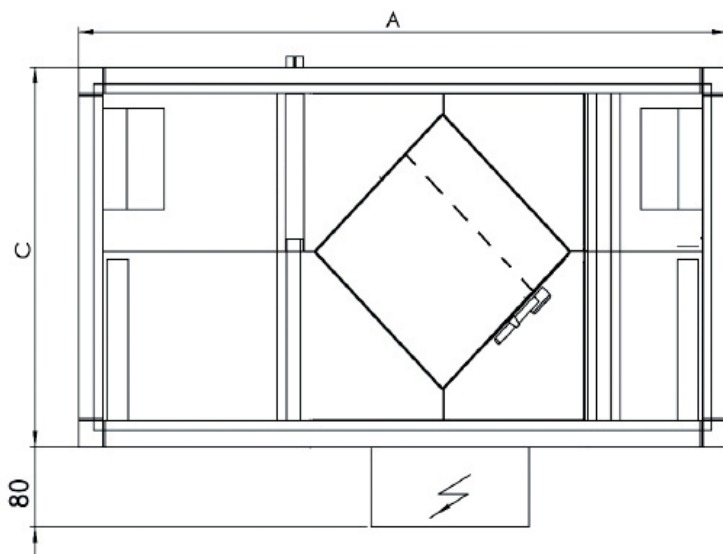
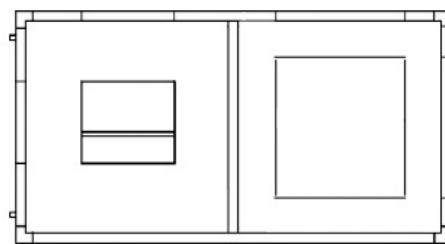
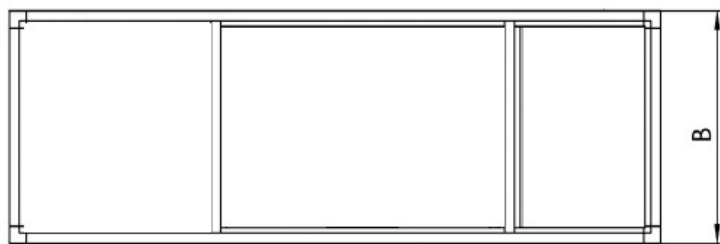

MODEL		40	75	100	150	200	320	UM
Dimension	A	1480	1450	1600	2000	2000	2100	mm
	B	380	480	550	680	680	680	mm
	C	800	990	1000	1290	1290	1400	mm
Weight		90	130	150	190	200	220	kg

> UT REC R+

ROTARY HEAT RECOVERY UNITS

ERP



Units Series

Version

UT REC R+ horizontal unit and standard fans
 UT REC RE+ horizontal unit EC fans

Unit specification

- Rotary, adsorption heat exchanger in aluminium with molecular sieve. Thermal efficiency up to 80%
- Constant air flow fans available on UT REC RE+ 100 - 400
- Case made by sandwich panels 23 mm thickness, galvanized inner skin and prepainted outer skin ; 45 kg/m³ density foamed polyurethane as heat and sound insulation
- Induction motor-heat exchanger assembly easily sideways removable.
- Full-range controlled direct driven double inlet centrifugal fans; **UT REC RE+** version with low consumption EC technology motors available
- Filtering sections composed by cell filters with polypropylene media, extractable from side removable panels, F7 efficiency for the fresh air flow, M5 efficiency for the exhaust air flow. low pressure drops filters
- Integrated pressure switch for dirty filter signal

Accessories

- Internal electric post-heating coil - **BER**
- Water cooling or heating coil section - **SBFR**
- High efficiency filters on exhaust air - **F7CF**
- Additional pressure switch - **PF**
- Regulation damper - **SR**
- 3 dampers defrosting section - **RMS**
- Damper actuators - **SM / SMR**
- Kit bypass management - **KBPR**
- N. 4 connections for circular kit - **SPC**
- Duct silencers - **SSC**
- Signal lamps kit - **KLS**
- Anti-freeze thermostat - **TA**
- Kit for external installation - **EXT**
- Kit weather hood for external installation - **CPA**
- Kit weather hood for external installation (UT REC R+) - **COM 3**
- Unit control panel - **PCU**
- Unit control panel with EC fans EC - **PCUE**
- Unit control panel with EC fans EC Modbus - **PCUEM**
- Unit control panel out 0-10V - **MCUE**
- Constant air flow fans control (UT REC RE+ 100 - 400) - **VSD**
- Integrated management system unit - **SIGB**
- Integrated management system wall mounted - **SIGQ**
- User terminal remote - **TUP**
- Modbus PCB - **SCMB**
- CO₂ sensor duct - **QSC**
- CO₂ sensor wall - **QSA**
- Humidity sensor duct - **USD**
- Humidity sensor wall - **USW**

Technical data

	40	75	100	150	200	320	400	UM
UT-REC R+								
Nominal air flow	310	640	1000	1650	2400	3200	3800	m ³ /h
Nominal external static pressure	230	130	190	160	300	180	100	Pa
Maximum external static pressure	230	130	190	160	300	180	100	Pa
Power supply	230/1/50				230/1/50-60			V/ph/Hz
Total full load amperage	1.5	2.9	6.0	6.0	14.0	14.0	14.0	A
UT-REC RE+								
Nominal air flow	310	640	1000	1650	2400	3200	3800	m ³ /h
Nominal external static pressure	230	130	190	160	300	180	100	Pa
Maximum external static pressure	430	280	560	600	480	460	230	Pa
Power supply	230/1/50				230/1/50-60			V/ph/Hz
Total full load amperage	2.4	2.4	9.0	9.0	9.0	10.0	10.0	A
UT-REC R+ Fans								
Motor typology	AC	AC	AC	AC	AC	AC	AC	-
Number of speeds ⁽¹⁾	4	3	3	3	3	3	3	-
Fan control ⁽¹⁾	Man	Man	Man	Man	Man	Man	Man	-
Internal specific fan power of ventilation components - SFP int ⁽⁵⁾	399	922	1033	884	777	965	931	W/(m ³ s)
Total nominal power input	0.15	0.34	0.63	0.80	1.66	2.04	1.59	kW
Sound pressure level ⁽²⁾	59	60	62	62	63	66	67	dB(A)
UT-REC RE+ Fans								
Motor typology	EC	EC	EC	EC	EC	EC	EC	-
Number of speeds ⁽¹⁾	Multiple	Multiple	Multiple	Multiple	Multiple	Multiple	Multiple	-
Fan control ⁽¹⁾	0-10V				0-10V VSD			-
Internal specific fan power of ventilation components - SFP int ⁽⁵⁾	377	803	802	727	612	566	872	W/(m ³ s)
Total nominal power input	0.14	0.29	0.49	0.66	1.31	1.20	1.48	kW
Sound pressure level ⁽²⁾	60	61	61	63	62	65	66	dB(A)
UT-REC R+ Heat exchanger								
Winter thermal effic ⁽³⁾	79.0	74.0	73.0	74.0	75.0	74.3	73.5	%
Winter enthalpy effic ⁽³⁾	74.0	69.0	58.0	60.0	62.0	60.2	59.0	%
Summer thermal effic ⁽⁴⁾	79.0	74.0	73.0	75.0	81.0	75.0	73.0	%
Summer enthalpy effic ⁽⁴⁾	69.0	65.0	59.0	60.0	65.0	59.5	59.0	%
Dry thermal efficiency ⁽⁵⁾	74.2	74.0	73.0	73.0	73.7	74.3	73.0	%
UT-REC RE+ Heat exchanger								
Winter thermal effic ⁽³⁾	79.0	74.0	73.0	74.0	75.0	74.3	73.5	%
Winter enthalpy effic ⁽³⁾	74.0	69.0	58.0	60.0	62.0	60.2	59.0	%
Summer thermal effic ⁽⁴⁾	79.0	74.0	73.0	75.0	81.0	75.0	73.0	%
Summer enthalpy effic ⁽⁴⁾	69.0	65.0	59.0	60.0	65.0	59.5	59.0	%
Dry thermal efficiency ⁽⁵⁾	74.2.0	74.0	73.0	74.0	73.7	74.3	73.0	%

NOTA

- (1) Multiple = Multispeed > 3 ;
 Man = Manual by selector switch or control panel;
 0-10V = By potentiometer or control panel;
 VSD = Constant flow control or modulation by air quality or air humidity sensor
- (2) Sound pressure level calculated at 1 m far from a ducted supply-exhaust air/ ducted; return-fresh air intake/service side, at nominal conditions.

- (3) Outside air at -5 80% RH; room air at 20 C 50% RH
 (4) Outside air at 32 50% RH; room air at 26 C 50% RH
 (5) Refer to EU 1253/2014 regulations at nominal pressure; air conditions refer to EN 308 standard

DIMENSIONS, WEIGHT

(drawing indicative of the series)

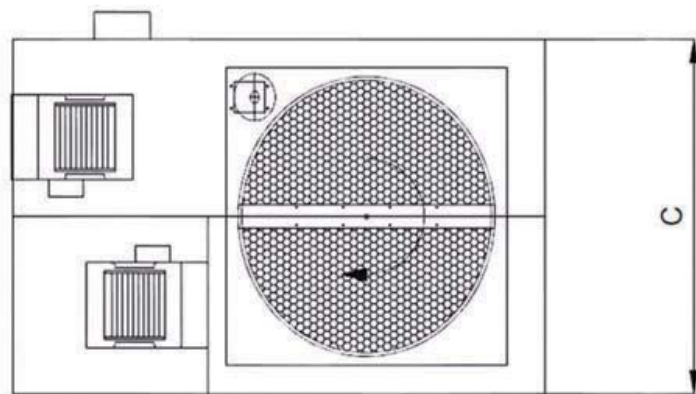
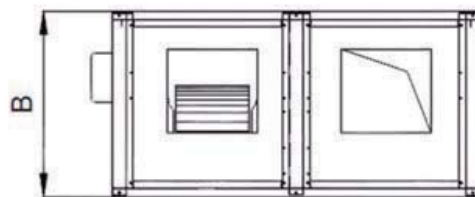
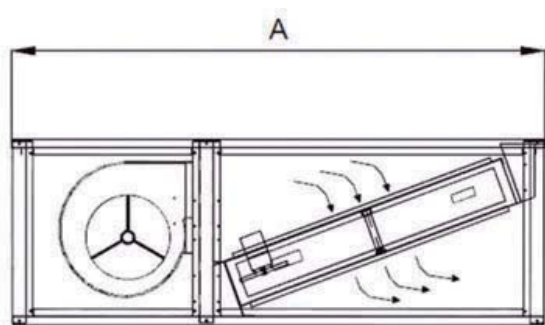

MODEL		40	75	100	150	200	320	400	UM
Dimension	A	1075	1075	1205	1400	1720	2000	2000	mm
	B	480	480	550	550	680	680	680	mm
	C	800	800	1000	1000	1290	1400	1400	mm
Weight		70	75	105	140	180	230	250	kg



HEAT PUMPS

> Technical datasheets	121
> Product range Heat pumps.....	132
> AIR-WATER Heat pumps	
RVL-I PLUS	134
HXP HT.....	146
HMP HT	150
HGA	154
HGA HT	158
HGP	162
HGP HT	166
> WATER-WATER and BRINE-WATER Heat pumps	
HSW LT	170
HXW LT	176
HMW LT.....	182
HMW HT	188
HGW HT	194
> Control accessories overview.....	200

HEAT PUMP SYSTEM BENEFITS

> A new strategy
for heating and
comfort

Satisfy the room
comfort needs using
the heat available
in the environment
as renewable and
inexhaustible energy
source



renewable source

The air, the water and the ground, the three most common elements on Earth, represent a virtually inexhaustible source of energy and heat, that the modern technology applied to heat pumps allow to be used in an optimized way in order to satisfy the heating and cooling needs of all the dwellings with efficient and ecological solutions.



energy efficiency

Heat pumps allow to get much higher efficiency levels compared to the traditional heating systems because they draw the main part of the required energy directly from the environment. The continuous improvement of the technologies applied to all the components and the constant optimization of the thermodynamic cycle, upon which the heat pump operating mode is based, allow to achieve always better performances.



operating costs reduction

The high energetic efficiency guaranteed by the heat pump and the advanced control system able to assure the maximum synergy between all the components of the plant allow to optimize the overall efficiency of the system during the whole year and to minimize the operating costs. The energy required to guarantee the room comfort is always produced in the most efficient way avoiding waste and taking advantage of the most convenient source both on the energetic and on the economical point of view.



domestic hot water production

Heat pumps can satisfy also the domestic hot water production needs coordinating the different requests by means of an accurate priority management. A proper water storage tank is always required in order to guarantee the maximum comfort in all the possible situations.

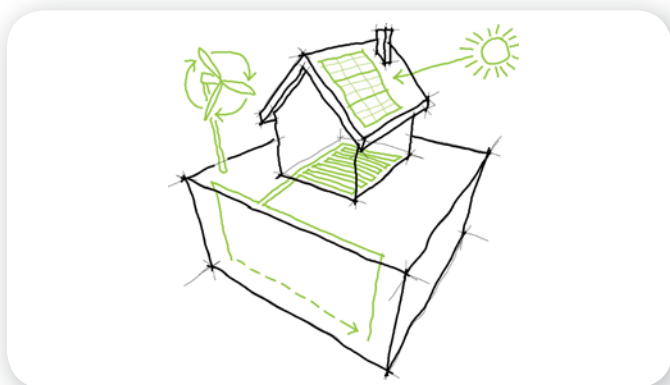

control and integration: the future is the system

The heat pumps are equipped with a control system that allow the management of the whole plant to coordinate all the available heating sources (heat pump, thermal solar, boiler, stove...) in order to satisfy in the best way the room comfort needs using the less quantity of energy as possible, produced in the most efficient way.



cooling function

The heat pump can also be used to produce cold water to be used in the cooling plant. The thermodynamic cycle inversion allow to reverse the normal heat flux that, instead of flowing from the outdoor environment to the plant, flows from the plant to the outdoor environment. The possibility to use the heat pump also for cooling extends the operating period also to the summertime making the heat pump a complete solution for the residential heating and cooling needs and exalting the advantages of the heat pump system in terms of efficiency, overall dimensions and integrated control.

IS THE HEAT PUMP CONSIDERED AS A "RENEWABLE SOURCE"?

> The outdoor environment (air, water and ground) contains a huge quantity of completely renewable thermal energy

The temperature level of all this energy does not allow its direct use in order to satisfy the heating requests

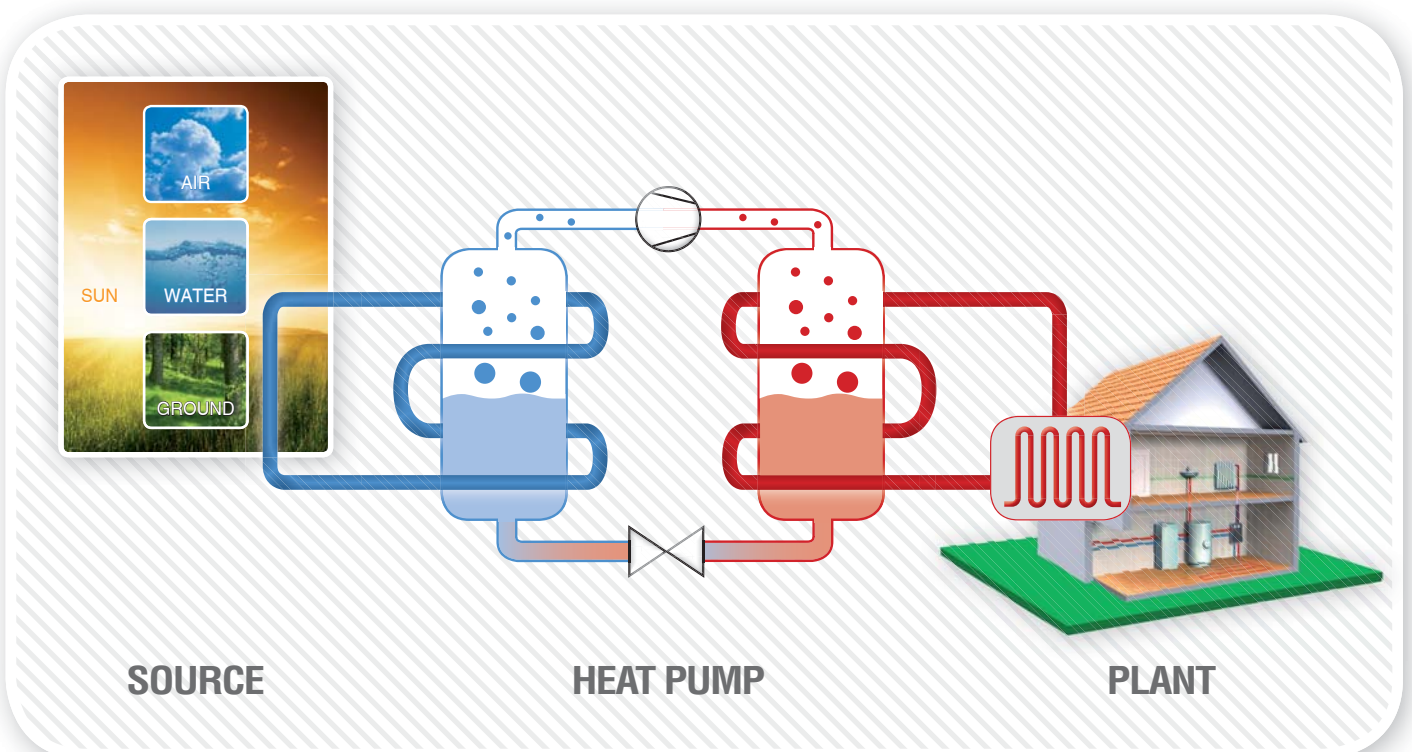

The heat pump is able to increase the temperature level of such energy and to transfer it to the plant by means of a thermodynamic cycle.

In order to perform such operation an amount of electrical energy (normally not renewable) is required. Also this energy is transformed in heat and released to the plant.

Therefore not all the thermal energy supplied by the heat pump can be considered as renewable but only the portion taken from the outdoor environment.

The heat pump could become a completely renewable source if also the electrical energy used to operate the thermodynamic cycle would come from a renewable source (i.e. photovoltaic, wind, hydroelectric...)

In order to quantify the renewable energy (Q_{ren}) produced by a heat pump is necessary to consider its seasonal performance factor (SPF) that represents the ratio between the useful energy (Q_c) available during the heating period and the electrical energy (L) required for the heat pump operation.

$$SPF = \frac{Q_c}{L}$$

The portion of energy that comes from renewable source, given by the difference between the total thermal energy available for the plant and the electrical energy used, is therefore as bigger as higher is the heat pump efficiency.

$$Q_{ren} = Q_c - L = Q_c \cdot \left(1 - \frac{1}{SPF}\right)$$

The seasonal efficiency of the modern heat pumps usually guarantees a **renewable energy percentage** variable from **75% to 100%** of the total thermal energy supplied.

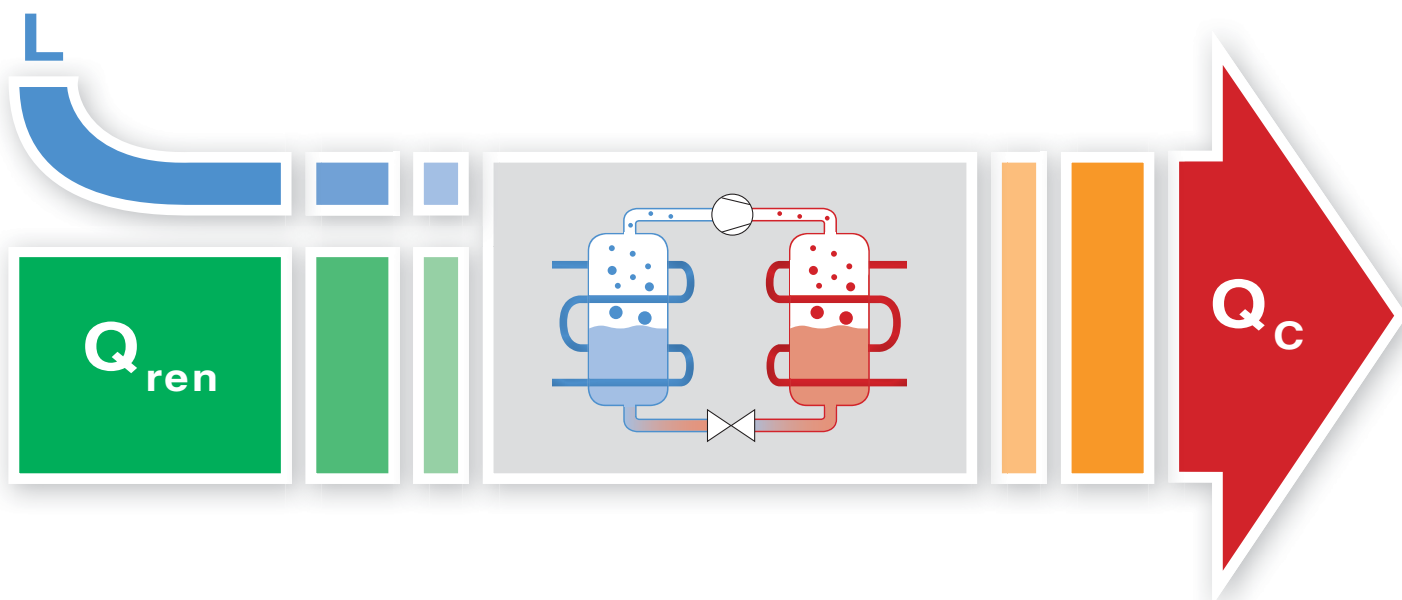

ENERGETIC ADVANTAGE

> The heat pump require **ELECTRICAL ENERGY** to work. In order to make a comparison with a traditional heating system that uses fossil fuel to work is necessary to consider the **PRIMARY ENERGY** consumption.



For the same amount of thermal energy supplied to the plant, the quantity of primary energy required with a traditional heating system depends only on the efficiency of the generator.

Considering as a traditional heating system a **CONDENSING BOILER** with an efficiency equal to 109%, to produce 100 thermal units, 92 primary energy units are required.

In the case of a **HEAT PUMP** the quantity of primary energy required depends on the heat pump efficiency (COP) and on the conversion efficiency of the primary energy into electrical energy. Considering a conversion efficiency equal to 46% and a COP equal to 3,3, to produce 100 thermal units, 30 electrical energy units are required, corresponding to 66 primary energy units.

When is the advantage guaranteed?

Considering a conversion efficiency equal to 46%, the heat pump system achieves a total efficiency, evaluated in terms of primary energy, higher than the one of a traditional heating system if the *COP* is higher than 2,36.

The modern heat pumps, if properly designed and installed, normally achieve a seasonal efficiency higher than such value and suitable to guarantee always the energetic advantage of the heat pump system over the traditional heating systems.



ECONOMIC ADVANTAGE

The three main factors to be taken into account are:

- > the electrical energy cost
- > the fossil fuel cost
- > the heat pump seasonal efficiency

Though the energetic advantage of the heat pump system over a traditional heating system is easily demonstrated, the economic advantage is affected by a much higher number of factors and particularly by the ratio between the electrical energy cost and the fossil fuel cost.

When is the advantage guaranteed?

When the cost of the electrical energy and of the fossil fuel are known, is easy to calculate which is the minimum seasonal efficiency that the heat pump has to guarantee in order to be the best solution also from an economic point of view.

Unlike a traditional heating system where the variability range of the generator efficiency is narrow, the heat pump systems can achieve seasonal efficiency levels very different according to:

> TYPE OF THERMAL SOURCE

> TYPE OF DISTRIBUTION PLANT

type of THERMAL SOURCE

The thermal source is the natural element from which the heat pump takes the thermal energy that is transferred to the plant, once its temperature level has been increased.

Heat pumps can be classified into two main groups:

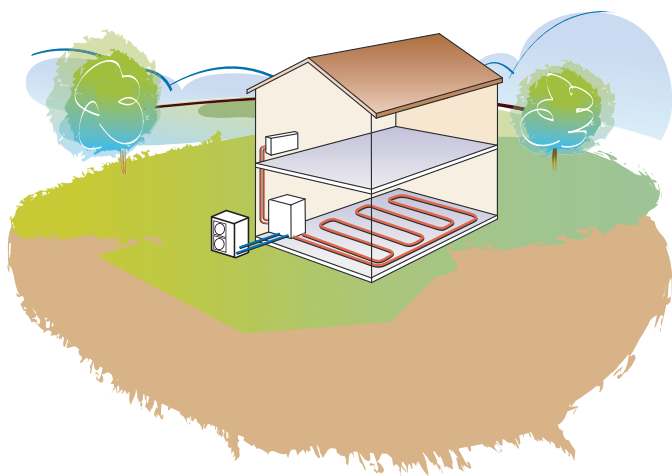

AIR-WATER

heat pumps

use the outdoor air as source

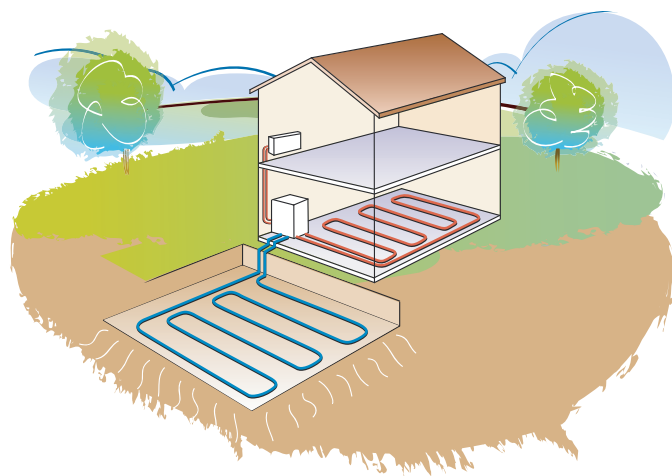

WATER-WATER

heat pumps

use the water as source (from well, river, lake or flowing inside geothermal probes)

type of DISTRIBUTION PLANT

The type of distribution plant strongly defines the temperature level at which the water inside the heat pump has to be heated. The lower the temperature of the water the higher is the efficiency of the heat pump.

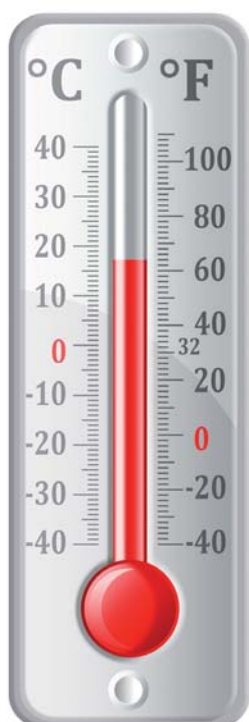

RADIATOR
60-70°C



FAN COIL
40-50°C



RADIANT PLANT
25-35°C



AIR - WATER HEAT PUMPS

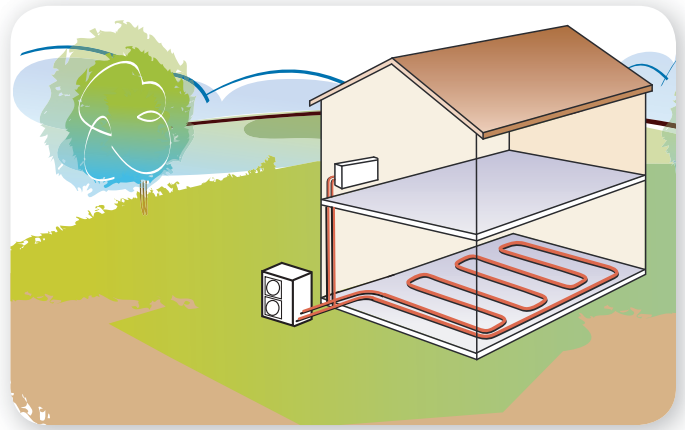

Outdoor air, often underestimated as thermal source, represents a very interesting solution, even in very cold and wet countries.

The technology evolution has lead air-water heat pumps to be not only reliable but also convenient thanks to their simple installation and to their lower investment cost compared to water-water heat pumps.

outdoor installation

The simplest solution to use the energy contained in the outdoor air is to install the heat pump directly outdoor.

It is necessary to reserve enough space around the heat pump to guarantee a proper air circulation and to prevent the freezing risk of the pipes that connect the heat pump to the plant using brine solutions or undergrounding completely the pipes.

> Type of installation

> Performances

bivalent operating mode

The heating capacity supplied by the heat pump decreases when the outdoor air temperature decreases (at -15°C the heating capacity is about the half compared to the corresponding capacity at 7°C). To satisfy the heating requests of the building, that increases when the outdoor air temperature decreases due to the higher thermal losses, without applying an uneconomic heat pump oversizing, is necessary to integrate the heating power supplied by the heat pump with

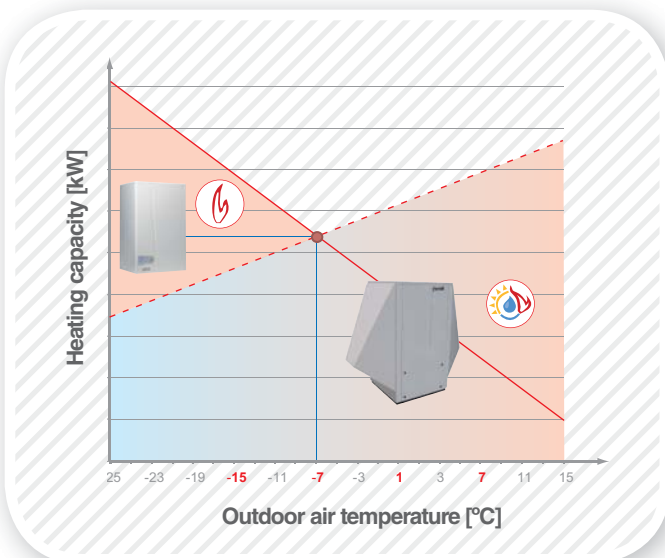

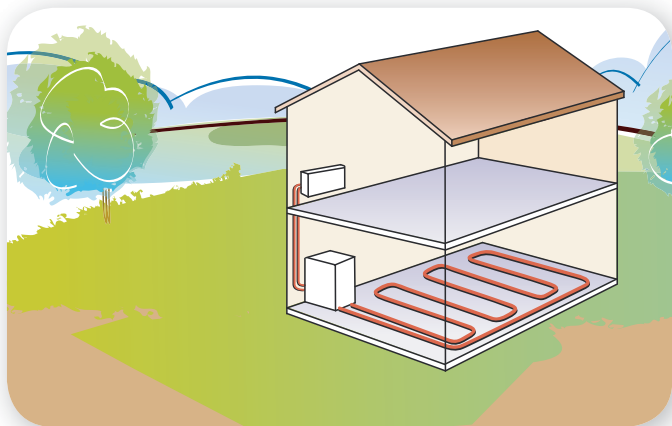

indoor installation

The heat pump, installed in a technical room inside the building, aspirates and ejects the outdoor air through properly designed ducts.

The advantages, besides the lack of an outdoor place dedicated to the heat pump and the corresponding aesthetic impact, are the outdoor noise emissions reduction, the possibility to perform all the maintenance operations in a technical room repaired from bad weather, the thermal losses reduction due to the outdoor pipes and the water pipes freezing risk elimination.

The heat pump efficiency is slightly penalized compared to the outdoor installation due to the higher electrical energy quantity required for the air circulation through the ducts.

This kind of installation allows to use the exhaust air to heat, with a recuperator, the air at the heat pump inlet in order to increase its efficiency.

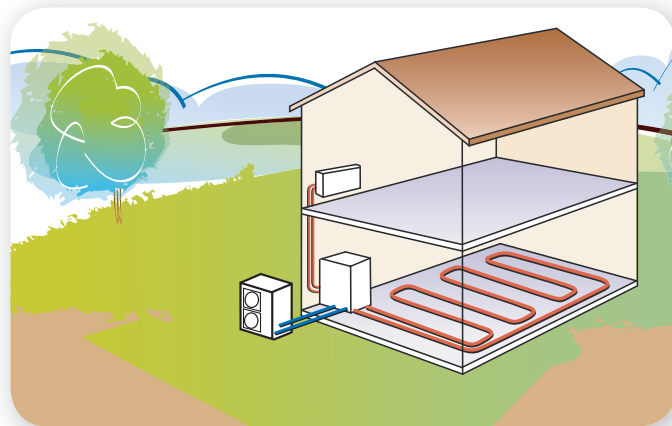

split installation

The heat pump is made of two units: one installed outdoor (extracts the heat from the air) and one installed indoor (transfers the heat to the plant). The two units are connected by means of refrigerant pipes, not affected by freezing risks, to be realized minimizing their length in order not to penalize the heat pump efficiency. Two solutions for this kind of installation are possible:

COMPRESSOR CONTAINED IN THE OUTDOOR UNIT:

the required place inside the building is very little as well as the indoor noise level is very low.

COMPRESSOR CONTAINED IN THE INDOOR UNIT:

the required place outside the building is very little as well as the outdoor noise level is very low and is possible to perform the maintenance operations in a technical room repaired from bad weather.

an auxiliary heating source (boiler, stove, electrical heaters...) performing a bivalent operating mode. Below a defined outdoor air temperature value the heat pump, in order to satisfy properly the plant requests, is integrated or replaced by an auxiliary heating source that, in well designed plants, covers only the peaks and does not significantly penalize the system seasonal efficiency.

defrosting cycles

When the outdoor air temperature is low, the humidity contained in the air tends to deposit on the surface of the finned coil of the heat pump producing a thin ice layer that reduces the thermal exchange capability and therefore the performances.

Periodically the proper operating mode of the heat pump is automatically restored by means of a defrosting cycle that, in order not to penalize the heat pump efficiency, has to be minimized in terms of length and frequency.

WATER - WATER HEAT PUMPS

Water and ground, thanks to their high thermal capacity, maintain during the whole year a very steady temperature at an average value higher than the one of the outdoor air allowing the water-water heat pumps to achieve absolutely the best efficiencies. Moreover the stability of the performances of the water-water heat pumps, due to source stability, allows to satisfy completely the plant needs without the necessity of an auxiliary heating source (monovalent operating mode). Though the plant realization is more complex and expensive compared to the air-water heat pumps, the water-water heat pumps have very small dimensions and very low noise levels that allow to be easily installed inside the building. Furthermore the absence of water pipes outdoor eliminates the freezing risk and reduces the thermal losses.

Type of sources

> GROUND Closed loop (geothermal)

The ground represents a huge energy reserve steadily regenerated through the sun and the rain. At depths higher than 15 meters the temperature is practically constant during the whole year and nearly equal to the annual average outdoor air temperature. The energy extraction from the ground is realized by means of *geothermal probes* made of pipes buried in the ground with a brine solution that flows inside them. Different types of probes are available but the most common are the vertical and the horizontal ones.

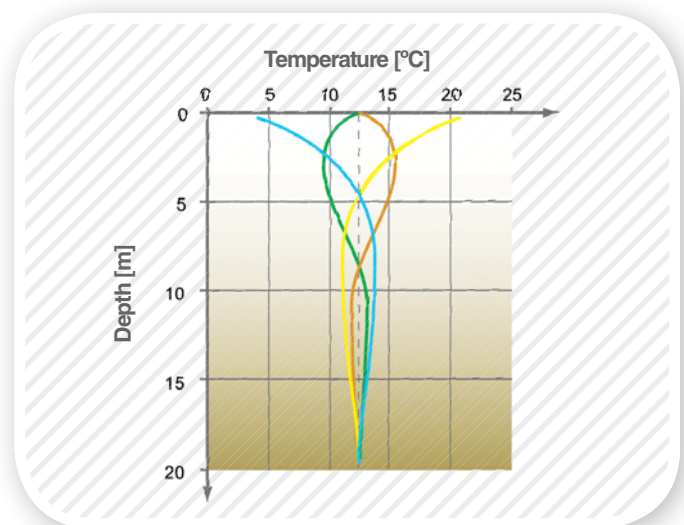

The design of the geothermal probes has to guarantee a proper heat exchange between the ground and the brine solution that flows inside them in order not to penalize the heat pump efficiency and capacity. The ground has to have the possibility to regenerate itself. A too intensive installation for the geothermal probes can produce a gradual lowering of the ground temperature that after few years would penalize the system performances. The possibility to use the heat pump also for cooling facilitates the ground regeneration bringing it back, during summer time, at the starting temperature level.

vertical probes

They are realized with pipes vertically inserted in the ground up to a depth of about 100 meters. They allow to taking better advantage of the ground temperature steadiness and they need a small surface. Their realization is however expensive and often bounded to the local regulations in force for groundwater respect.

horizontal probes

They are realized with pipes horizontally distributed on the ground at a depth of about 2 meters. They are simple and cheap to be realized but they require a large surface free from asphalt and trees and they are much more influenced by the ground temperature oscillations.

VERTICAL PROBES



HORIZONTAL PROBES

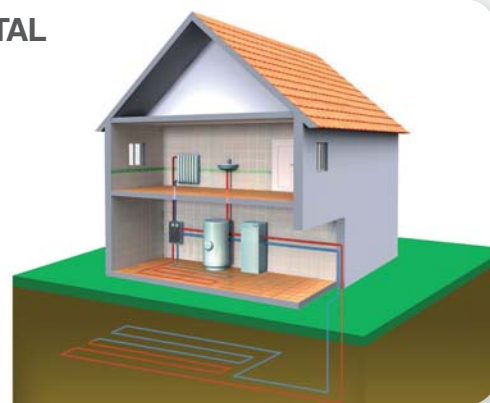

> WATER

Open loop

The heat pump extracts the energy directly from the water taken from wells, rivers, lakes... The water enters directly in the heat pump and is then released in the environment. The absence of intermediate heat exchanges allows to optimize the system efficiency. On the other hand it is necessary to pay attention not to pollute the used water and not to modify too much the temperature respecting the local regulations in force, often very restrictive

groundwater

It guarantees a higher temperature steadiness but requires a higher power input for the water extraction. Moreover it is necessary to realize two independent wells, one for extraction and one for admission, respecting the local regulations in force. In any case it is recommended to verify the quality and the cleaning of the water in order to avoid the heat pump heat exchanger fouling and corrosion. The presence of intermediate heat exchangers, required not to send the source water directly in the heat pump heat exchanger, must be considered in the system performances evaluation.

surface water

The surface water should be preferred to reduce the energy required to the source side pump operation.

SURFACE WATER



GROUND WATER

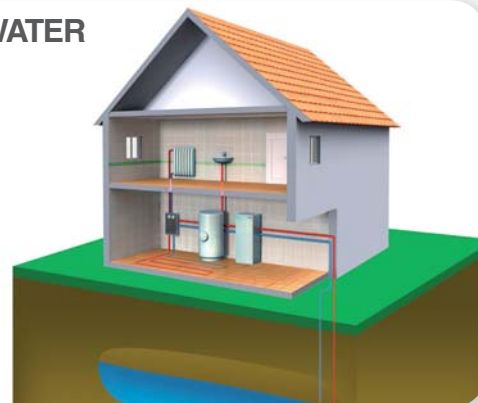

THE HEAT PUMP INTEGRATED INSIDE THE PLANT

The constant evolution of the different components that are involved in the plant is not enough in order to guarantee to obtain the best possible total performances. Only the coordination between all the available heating sources and an integrated management of the distribution systems are able to guarantee to satisfy in every moment and in the best way the comfort needs using the minimum energy quantity as possible, generated in the most efficient way as possible.

The heat pump controller is able to perform all these functions by means of advanced control algorithms and smart logics of activation and coordination of the plant components.

> Tank for the plant when is it necessary?

The tank for the plant is often considered as an expensive and large component that is necessary to "protect" the heat pump. *Indeed the heat pump works properly and in an absolutely safe way also without tank.*

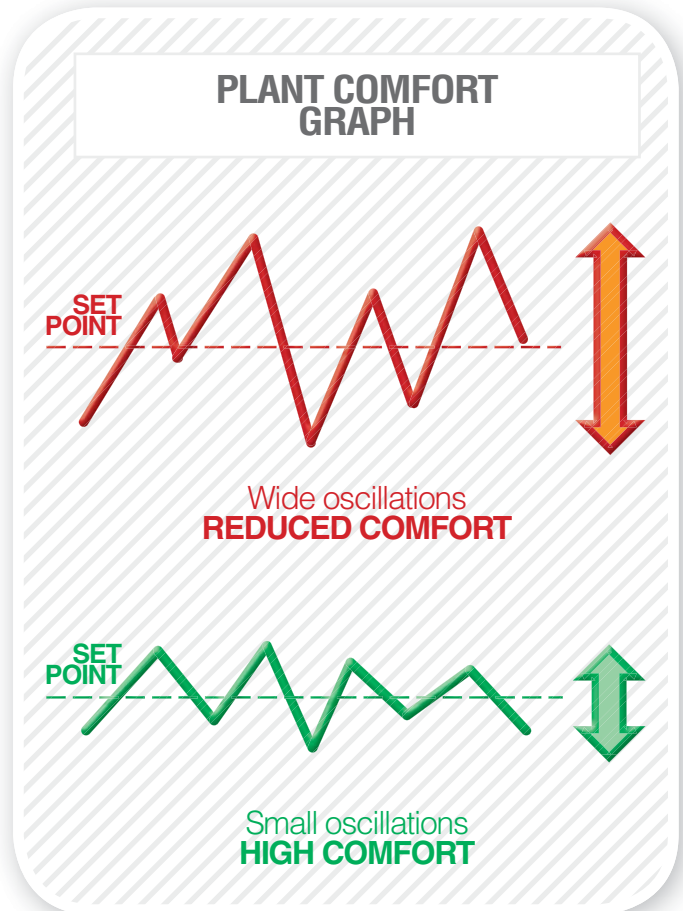

When the heat pump is connected to distribution plant with a low water content (i.e. radiator plants or fan coil plants) the temperature oscillations of the water sent to the hydronic terminals can become very wide causing *not comfortable situations* in the ambient.

In order to restrict the temperature oscillations it is necessary to increase the *thermal inertia* of the plant increasing the available water volume so as to slowing down the temperature variations and allow the system to dynamically adapt to plant needs keeping a high comfort level.

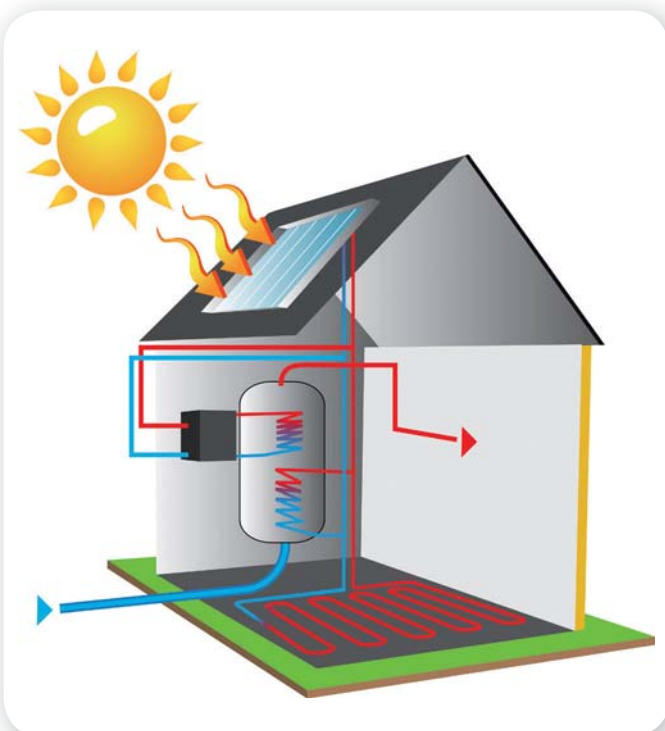

the main functions of the tank for the plant

Besides the function of stabilize the water temperature in the plant, the tank has a lot of other functions that are highlighted in the modern plants, more and more advanced and complex.

The tank thermal inertia allow to stabilize the water temperature in the plant in order to guarantee a constant ambient temperature (perceived by the user as comfortable).

In plant equipped with AIR-WATER heat pumps the tank allows NOT to send cold water to the hydronic terminals during the defrosting cycles.

The tank is the connection point between the different heating sources (heat pump, solar panel, boiler, stove...) and the distribution circuits (radiant circuits, fan coil circuits, radiator circuits...). The heating requests coming from the building are converted, by means of climatic curves optimized for each circuit, into a single set point for the tank that dynamically changes to be always optimized to guarantee the best efficiency.

The tank temperature becomes a fundamental index to carry out the coordination logics of the available heating sources.

The tank allows to produce thermal energy when is much more convenient and to use it when is requested by the plant.

For example it is possible to take advantage of the time slots during which the electrical energy is cheaper or to use an overproduction coming from photovoltaic panels.

The tank allows to reduce the heating request peaks and therefore to install smaller heat pumps with a corresponding reduction of the committed electrical power.

The possibility to use the tank temperature to coordinate the available heating sources allows moreover to optimize the circulation pumps management activating them only when necessary.

Without tank it would be necessary to maintain a water flow through the heat pump heat exchanger to control the return temperature and keep it close to the set point value.

The tank allows to satisfy the heating needs with the thermal energy produced by other renewable sources like solar thermal or biomass since their availability and the plant needs not always occur at the same time.

The tank represent a thermal energy storage that guarantees the plant to be in some extent autonomous also when the heat pump is used to satisfy other needs (for example in the domestic hot water production) or the electrical energy is not available.

For example in many european countries electrical power supply contracts are available that can offer a lower energy cost if the user can accept the power supply to be interrupted up to 2 hours in a row. In such cases the tank is chosen according to this specific need.



> Domestic hot water

Which are the differences with a traditional system

The domestic hot water production with a heat pump always requires a *tank*. The instantaneous domestic hot water production would require a too high absorbed electrical power for residential applications. Moreover with the heat pump is not possible to heat the water inside the tank up to temperatures higher than 50-55°C (according to the kind of heat pump).

tank containing domestic hot water

The tank contains domestic hot water ready to be used that can be heated in two different ways.

COIL The tank is heated by means of a coil inside which the hot water produced by the heat pump flows. The coil must be properly sized in order to be coupled with heat pumps (at least a surface of 0,5 m² per heating power kW supplied by the heat pump are recommended).

"PRIMARY" HEAT EXCHANGER The tank is heated by means of an external heat exchanger placed between the heat pump and the tank. The efficiency of the thermal exchange is higher than the one of the coil and allows to get higher temperatures inside the tank with the same water temperature produced by the heat pump.

In both cases the disinfection legionella cycles, if necessary, must be performed with the help of an auxiliary heating source (electrical heaters, boiler, solar...)

tank containing "technical" water

The tank contains hot water to be used to produce instantaneously domestic hot water, just when it is requested, by means of an external

"SECONDARY" HEAT EXCHANGER.

The hot water contained inside the tank is not affected by the legionella problem.

> Heating sources

How to optimize their use?

To optimize the integration of different heating sources within the same plant is necessary to use in every moment the source that is able to satisfy the plant needs in the most efficient way, both on the energetic point of view and on the economic point of view.

The heat pump controller allows to customize the control logic that enables the available sources modifying some activation thresholds according to the cost of the different energy sources and the features of the generators installed in the plant. Generally the most common logic according which the priority are assigned is realized by the activation in sequence of :

- > *THERMAL SOLAR (both for domestic hot water production and for heating)*
- > *WATER-WATER heat pump*
- > *AIR-WATER heat pump*
- > *COMBUSTION generators (boiler, stove...)*
- > *ELECTRICAL HEATERS*





TECHNICAL datasheets

OPERATING RANGE

AIR-WATER HEAT PUMPS

HEATING

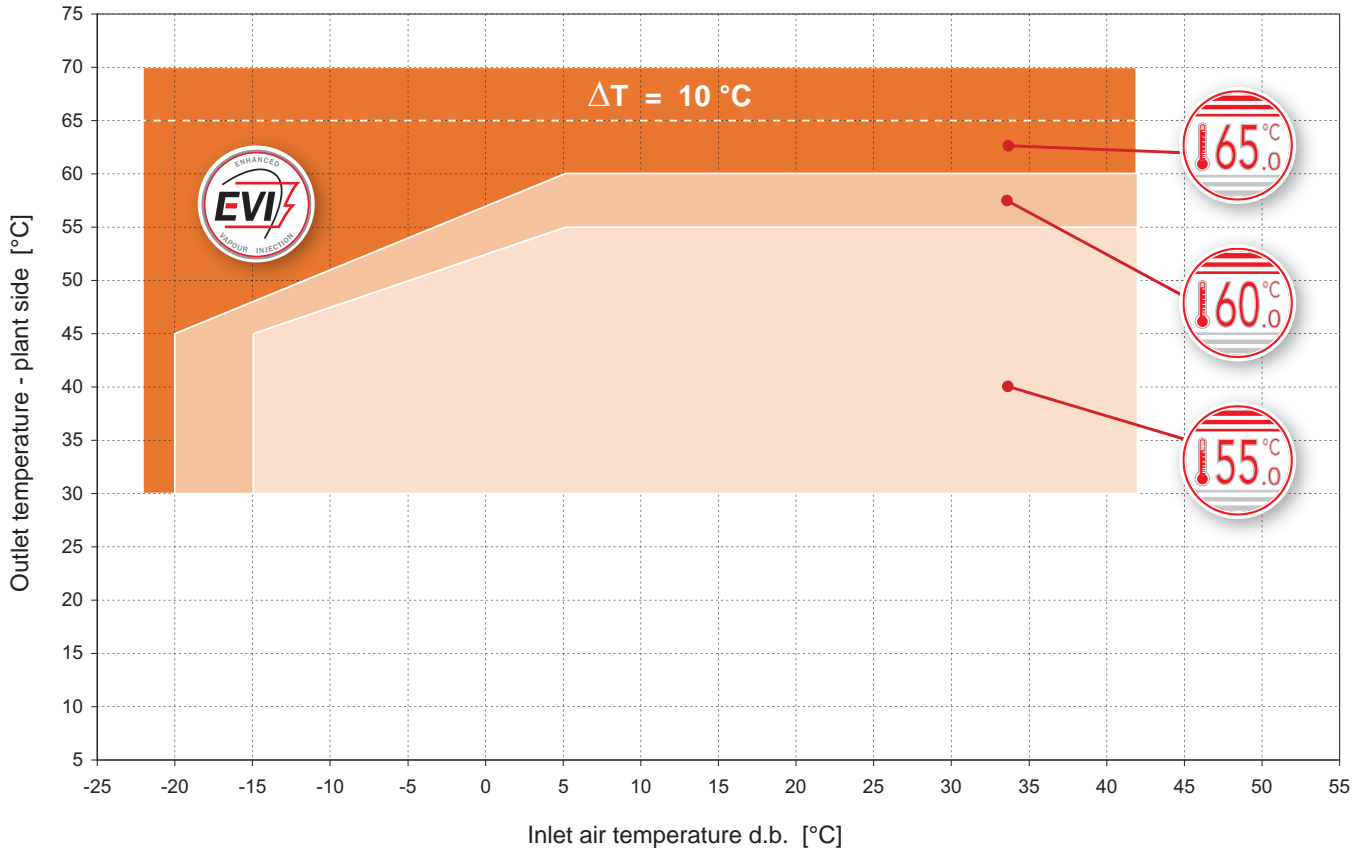

COOLING

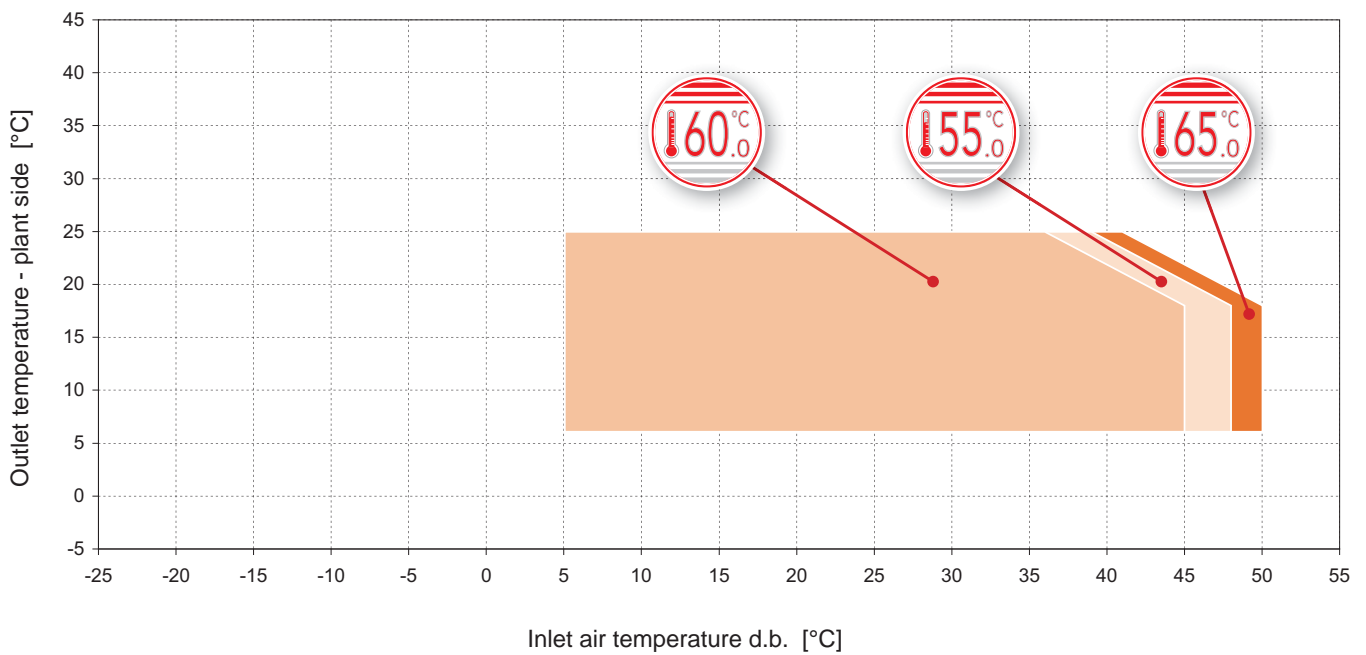

WATER-WATER HEAT PUMPS

HEATING

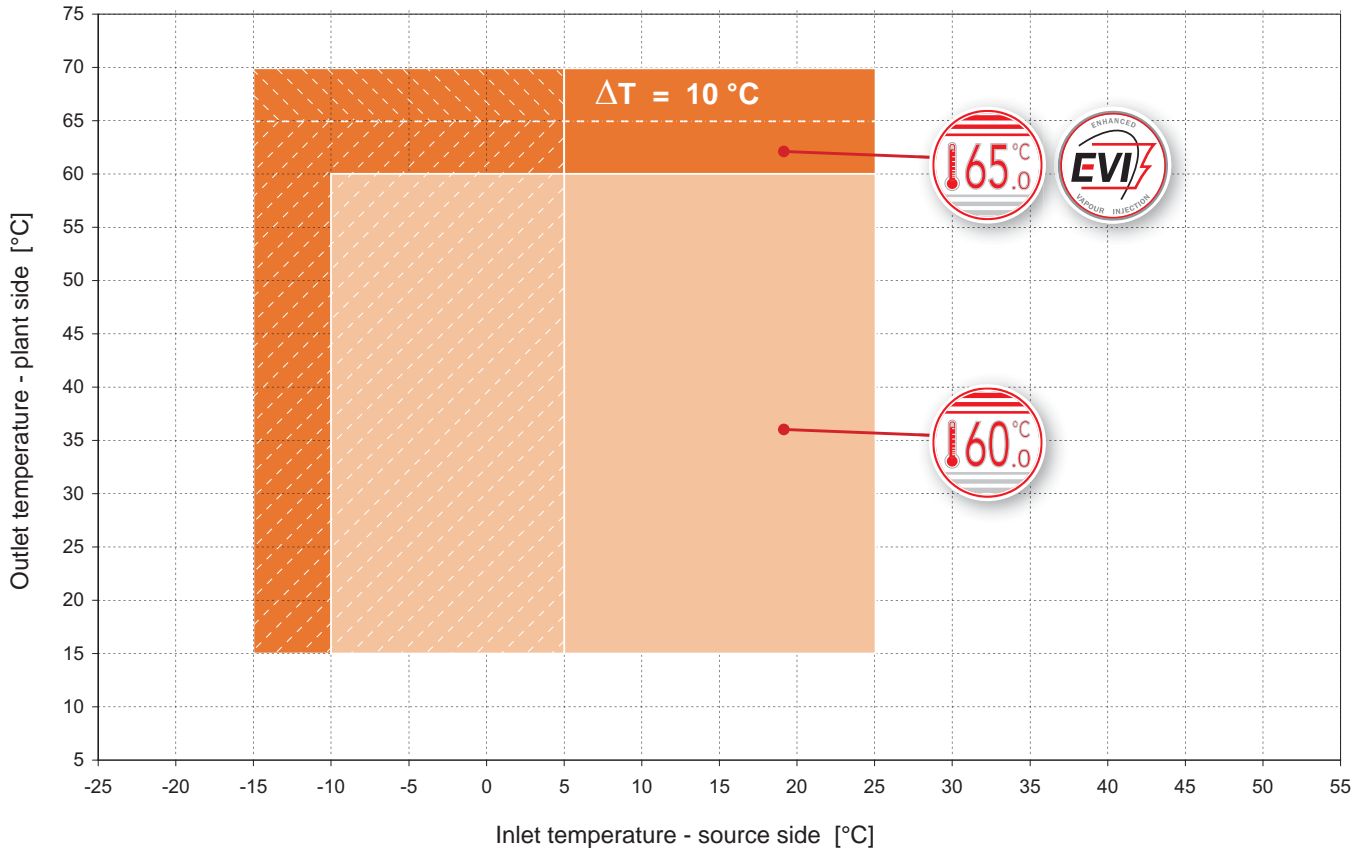

COOLING

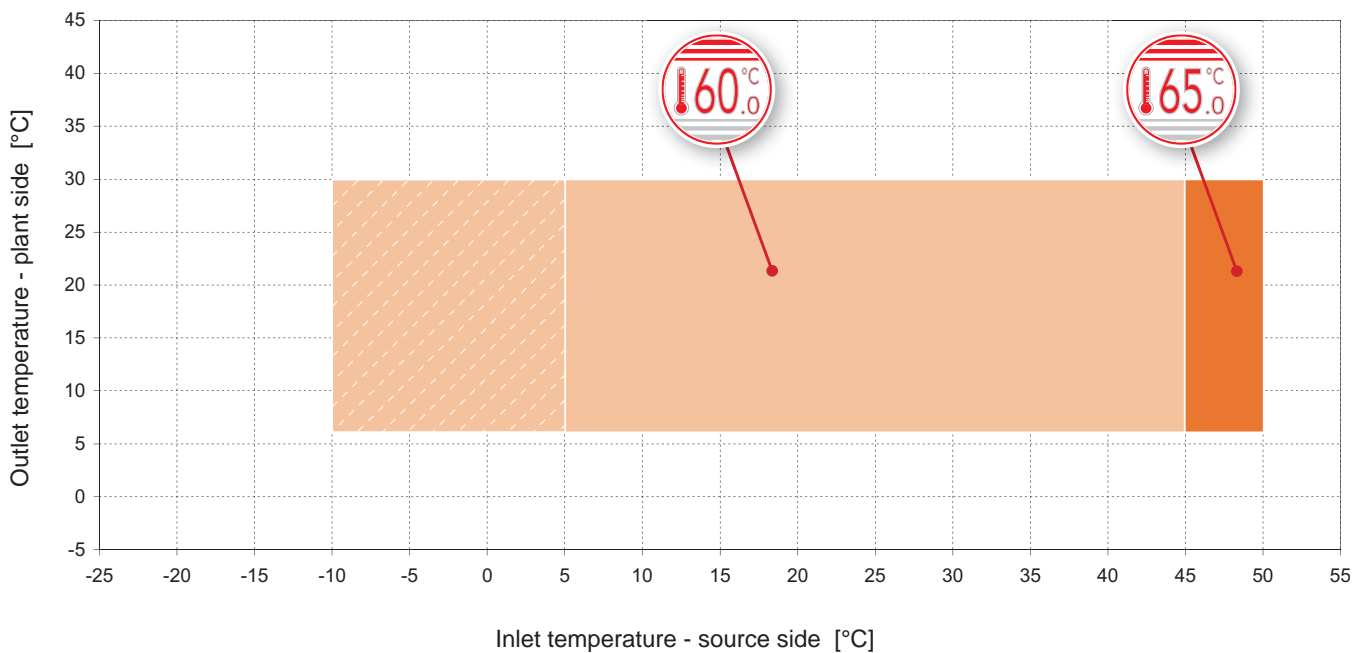

The dotted lines show the operating area when brine solutions in the source side hydraulic circuit are used.

> PERFORMANCES IN HEATING

AIR-WATER HEAT PUMPS

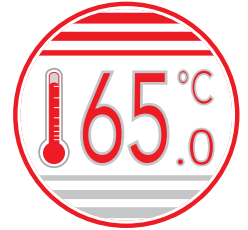

Heating capacity

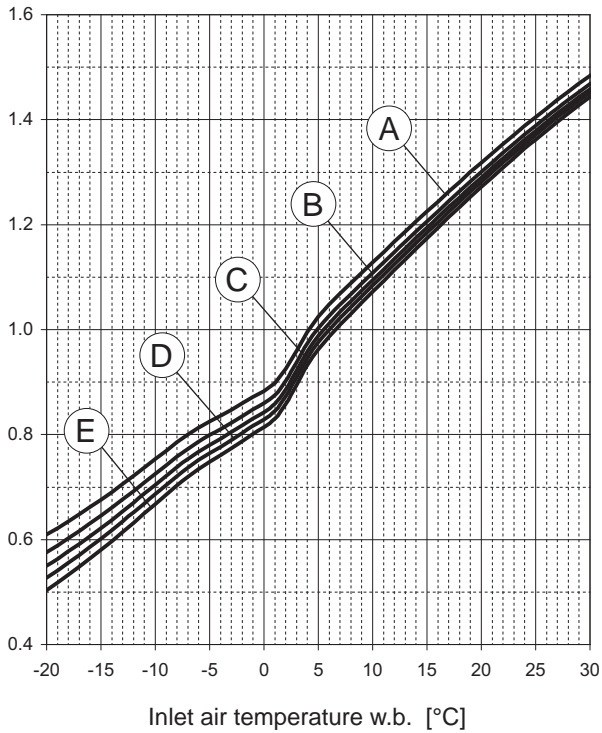

The graphs allow to get the corrective factors to be applied to the nominal performances in order to obtain the real performances in the selected operating conditions.

The reference nominal condition is :

A7W35

source : air in 7°C d.b. 6°C w.b.

plant : water in 30°C out 35°C

Outlet temperature

plant side :

A = 65°C

B = 55°C

C = 45°C

D = 35°C

E = 25°C



Power input

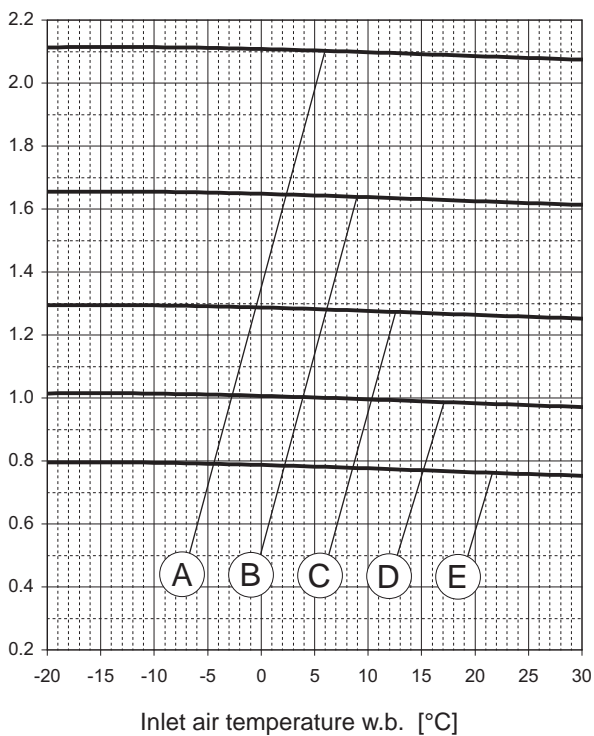

COP

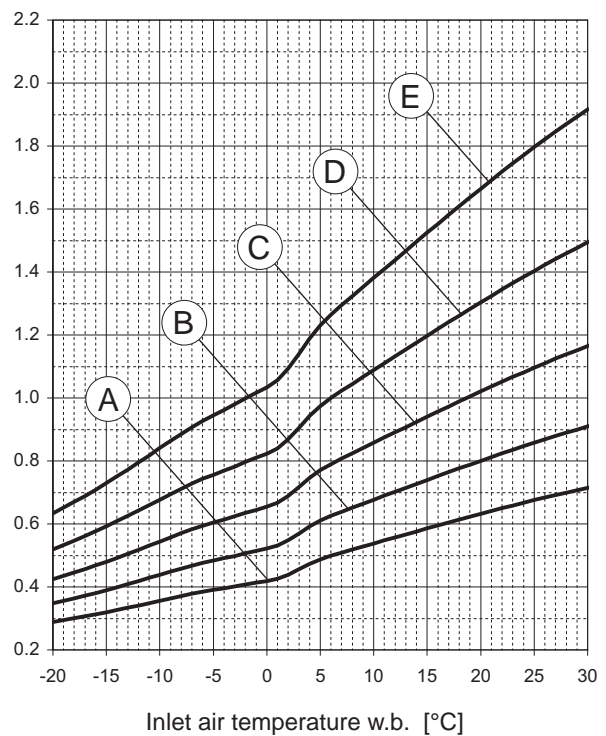

> PERFORMANCES IN COOLING

AIR-WATER HEAT PUMPS

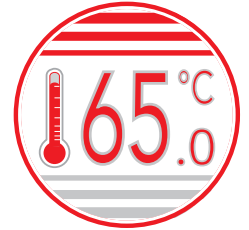

Cooling capacity

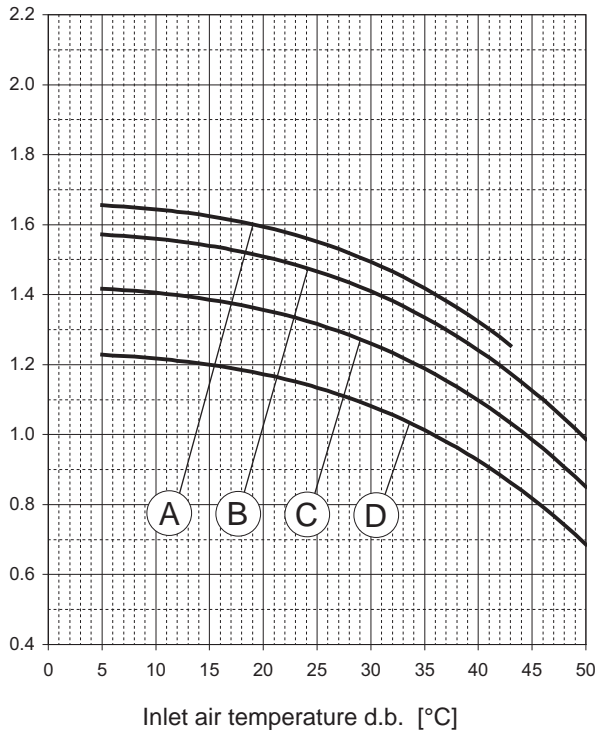

The graphs allow to get the corrective factors to be applied to the nominal performances in order to obtain the real performances in the selected operating conditions.

The reference nominal condition is :

A35W7

source : air in 35°C d.b.

plant : water in 12°C out 7°C

Outlet temperature

plant side :

A = 24°C

B = 18°C

C = 12°C

D = 7°C

Power input

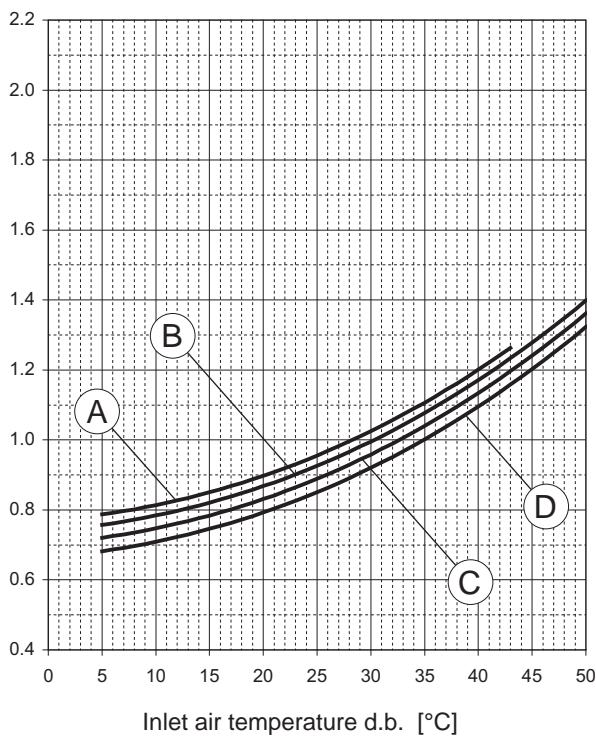

EER

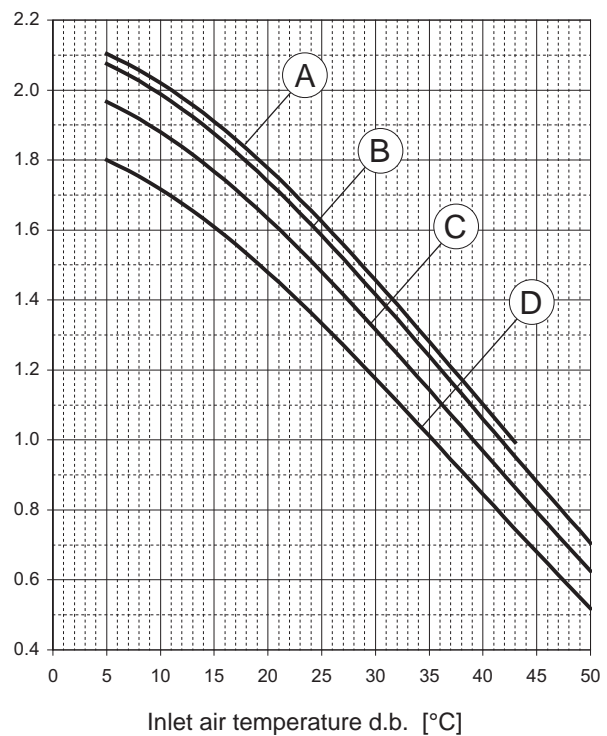

> PERFORMANCES IN HEATING

AIR-WATER HEAT PUMPS

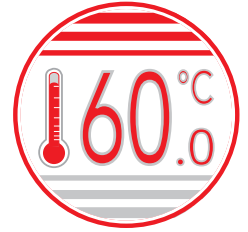

Heating capacity

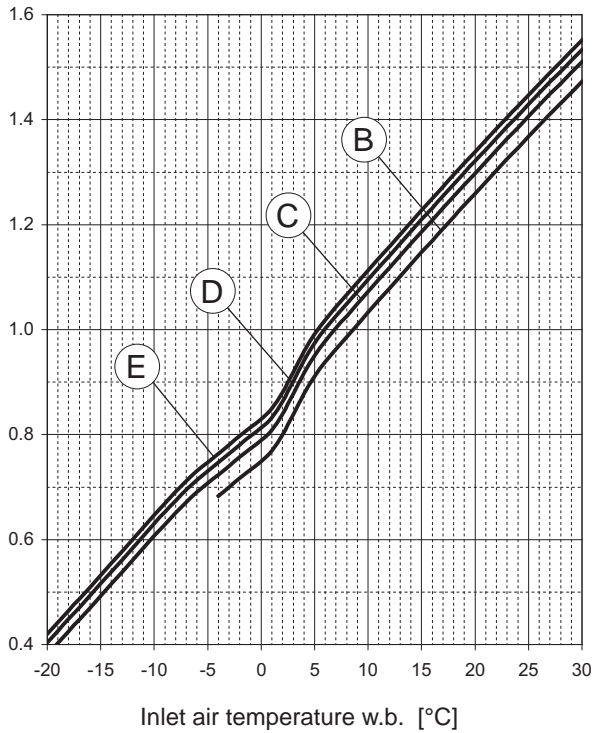

The graphs allow to get the corrective factors to be applied to the nominal performances in order to obtain the real performances in the selected operating conditions.

The reference nominal condition is :

A7W35

source : air in 7°C d.b. 6°C w.b.

plant : water in 30°C out 35°C

Outlet temperature

plant side :

A = 65°C

B = 55°C

C = 45°C

D = 35°C

E = 25°C

Power input

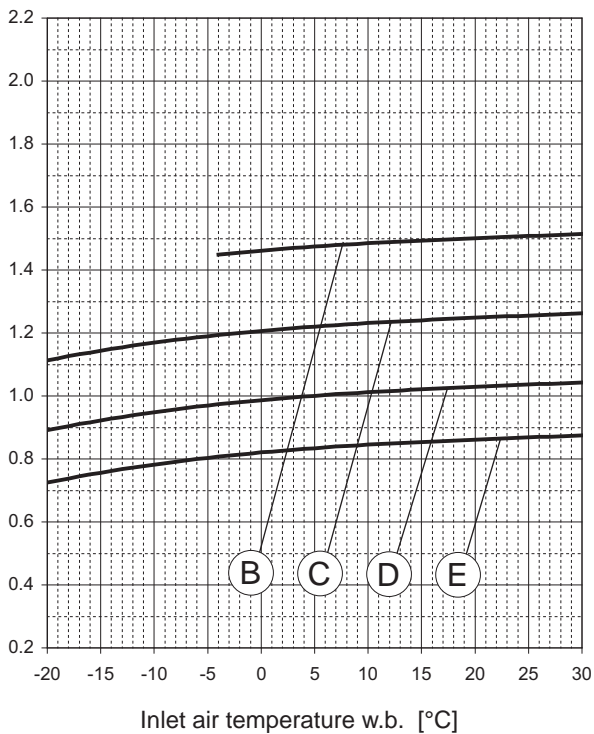

COP

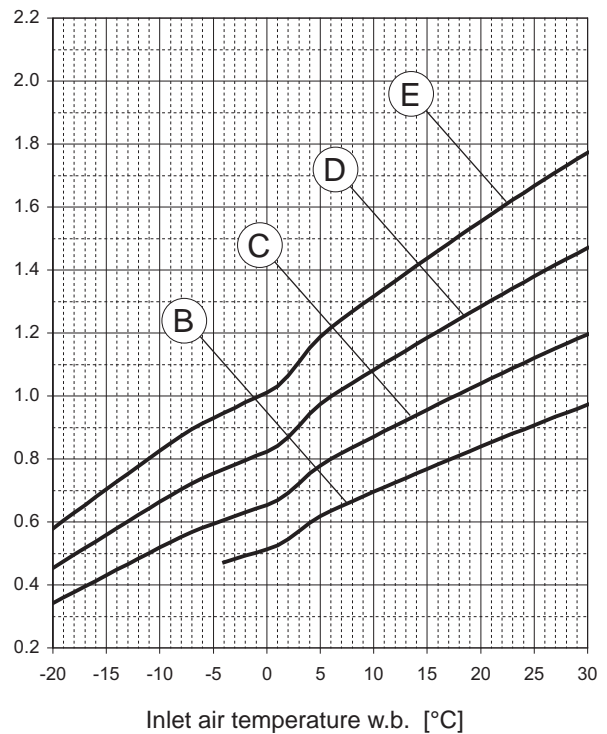

> PERFORMANCES IN COOLING

AIR-WATER HEAT PUMPS

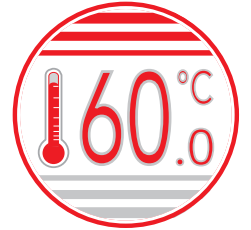

Cooling capacity

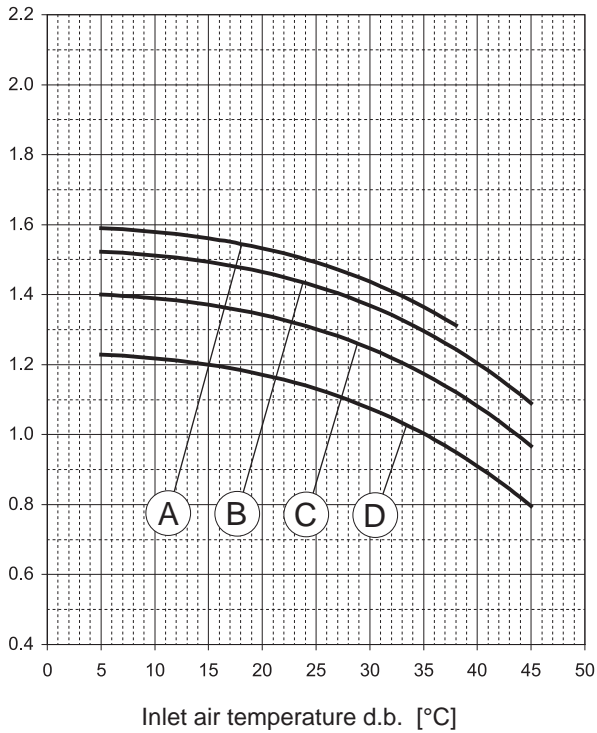

The graphs allow to get the corrective factors to be applied to the nominal performances in order to obtain the real performances in the selected operating conditions.

The reference nominal condition is :

A35W7

source : air in 35°C d.b.

plant : water in 12°C out 7°C

Outlet temperature

plant side :

A = 24°C

B = 18°C

C = 12°C

D = 7°C

Power input

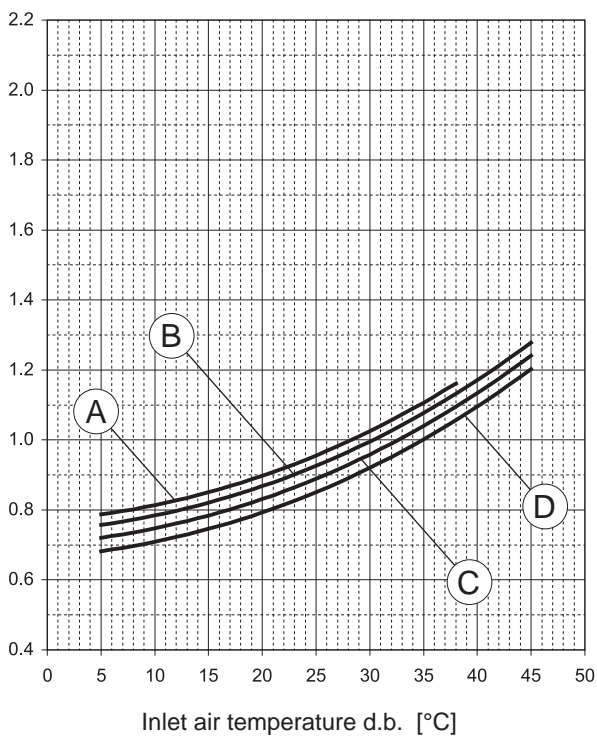

EER

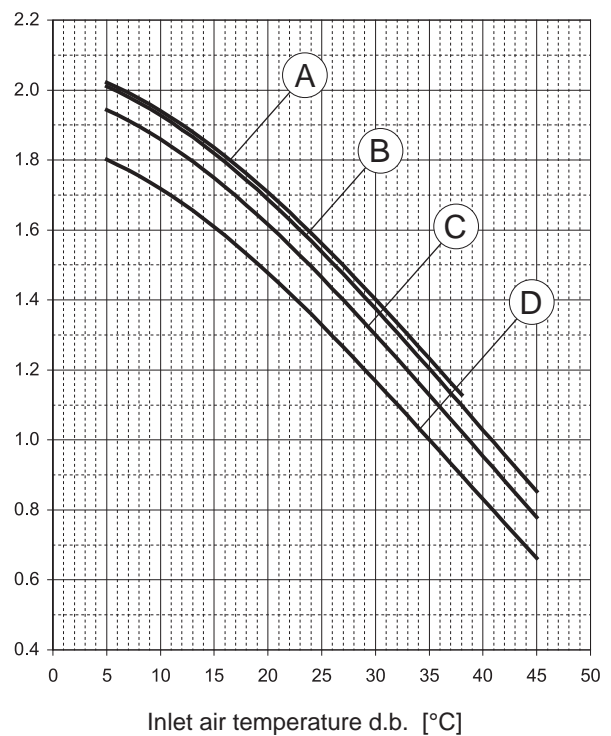

> PERFORMANCES IN HEATING

WATER-WATER HEAT PUMPS

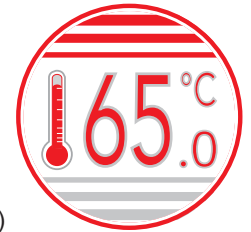

Heating capacity

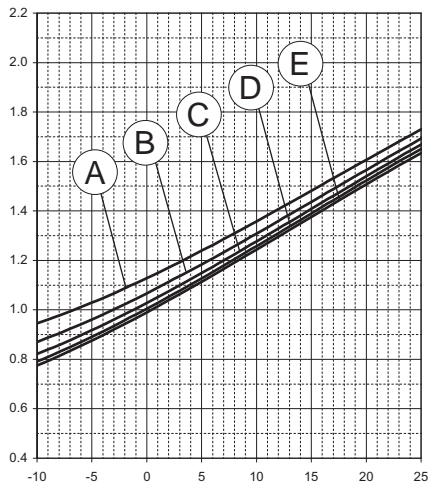

Inlet temperature - source side [°C]

Heating capacity (water)

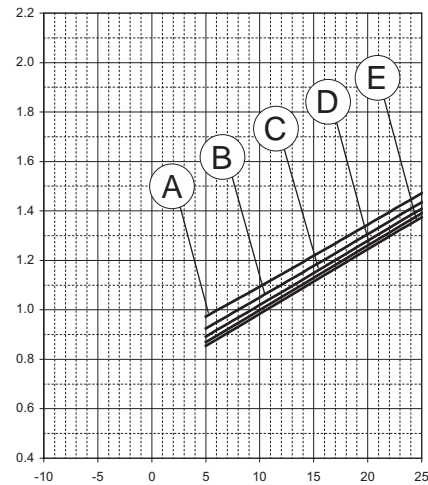

Inlet temperature - source side [°C]

Power input (brine and water)

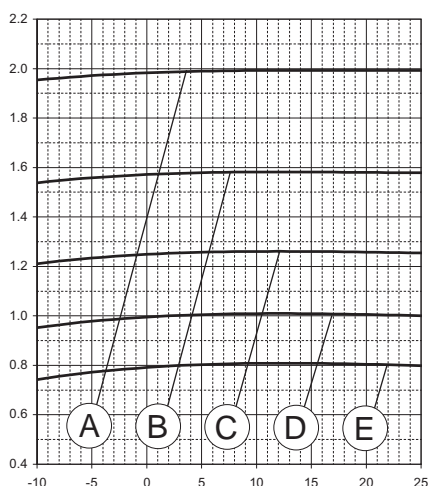

Inlet temperature - source side [°C]

COP (brine)

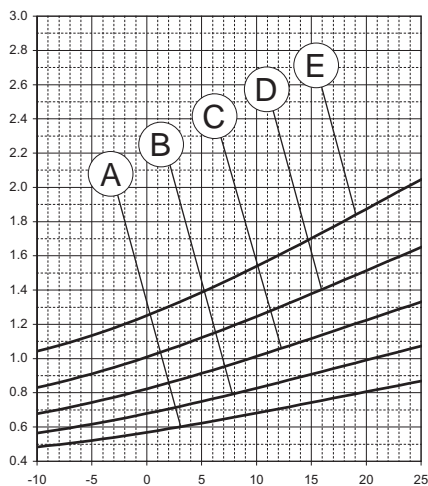

Inlet temperature - source side [°C]

COP (water)

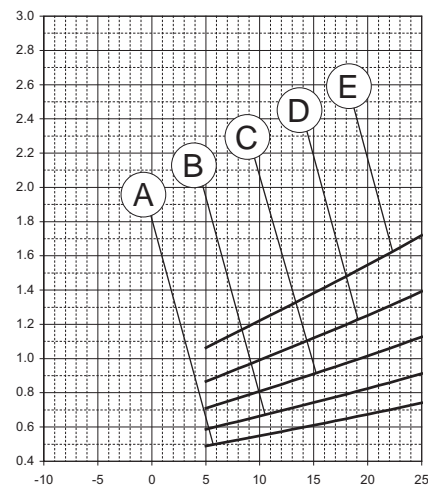

Inlet temperature - source side [°C]

The graphs allow to get the corrective factors to be applied to the nominal performances in order to obtain the real performances in the selected operating conditions.

The reference nominal conditions are :

WATER-WATER units : W10W35

source : water in 10°C out 7°C

plant : water in 30°C out 35°C

BRINE-WATER units : B0W35

source : brine in 0°C out -3°C

plant : water in 30°C out 35°C

Outlet temperature

plant side :

A = 65°C

B = 55°C

C = 45°C

D = 35°C

E = 25°C



> PERFORMANCES IN COOLING

WATER-WATER HEAT PUMPS

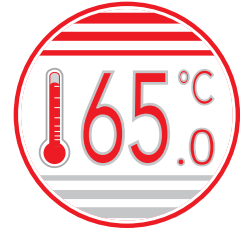

Cooling capacity (brine and water)

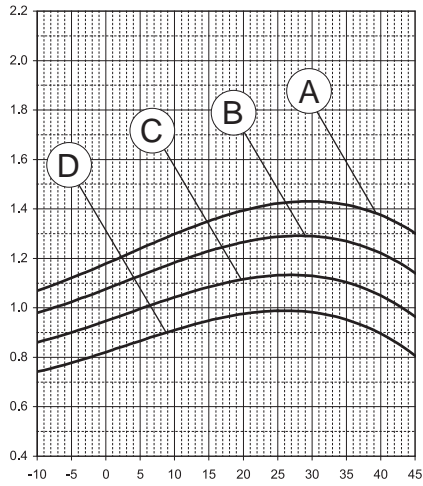

Inlet temperature - source side [°C]

Power input (brine and water)

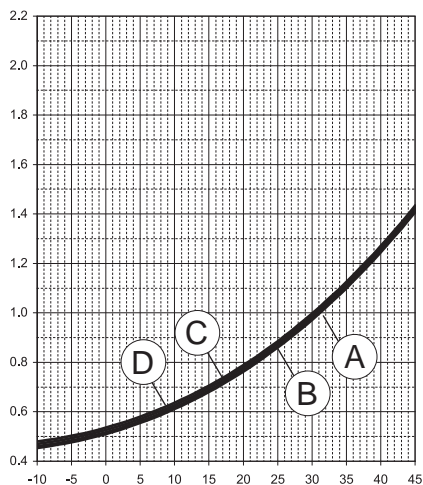

Inlet temperature - source side [°C]

EER (brine and water)

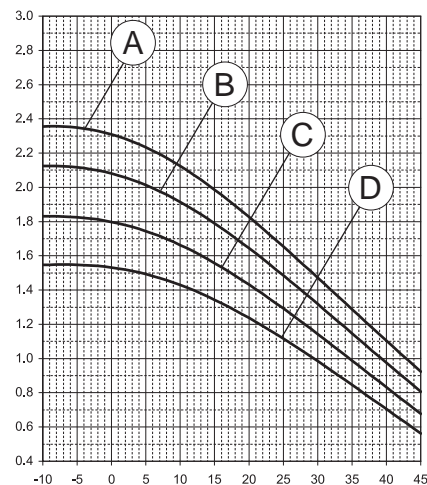

Inlet temperature - source side [°C]

The graphs allow to get the corrective factors to be applied to the nominal performances in order to obtain the real performances in the selected operating conditions.

The reference nominal conditions are :

WATER-WATER units : W30W7

source : water in 30°C out 35°C

plant : water in 12°C out 7°C

BRINE-WATER units : B30W7

source : brine in 30°C out 35°C

plant : water in 12°C out 7°C

Outlet temperature

plant side :

A = 24°C

B = 18°C

C = 12°C

D = 7°C

The performances of the units, when used as brine - water, are referred to applications in which the source side fluid is a solution of water and 30% ethylene glycol by volume.

Such a concentration guarantees a freezing temperature of about -15°C and allows the unit to work inside the declared operating limits.

> PERFORMANCES IN HEATING

WATER-WATER HEAT PUMPS

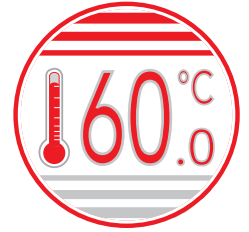

Heating capacity

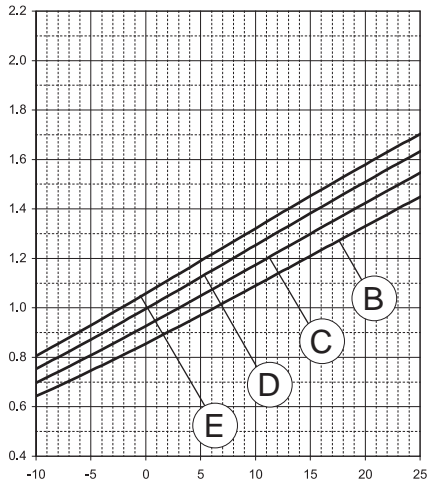

Inlet temperature - source side [°C]

Heating capacity (water)

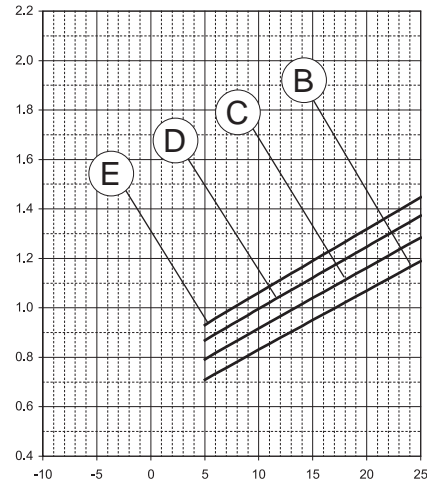

Inlet temperature - source side [°C]

Power input (brine and water)

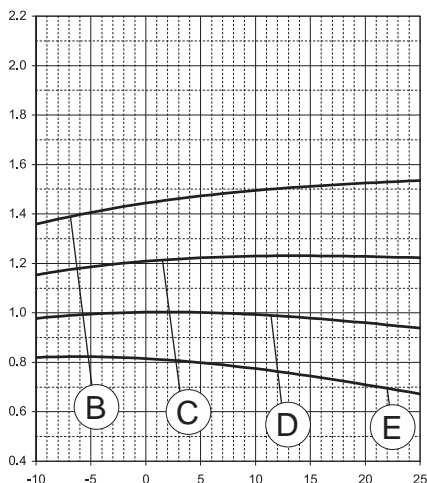

Inlet temperature - source side [°C]

The graphs allow to get the corrective factors to be applied to the nominal performances in order to obtain the real performances in the selected operating conditions.

The reference nominal conditions are :

WATER-WATER units : W10W35

source : water in 10°C out 7°C

plant : water in 30°C out 35°C

BRINE-WATER units : B0W35

source : brine in 0°C out -3°C

plant : water in 30°C out 35°C

Outlet temperature

plant side :

A = 65°C

B = 55°C

C = 45°C

D = 35°C

E = 25°C

COP (brine)

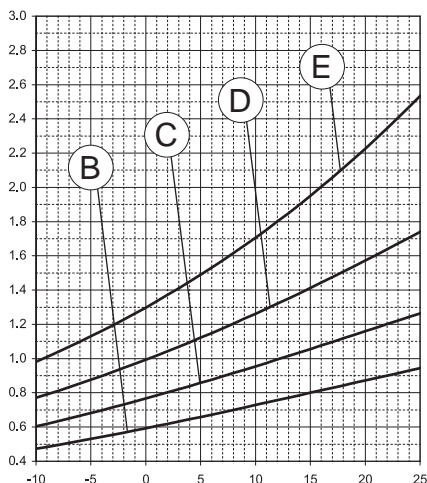

Inlet temperature - source side [°C]

COP (water)

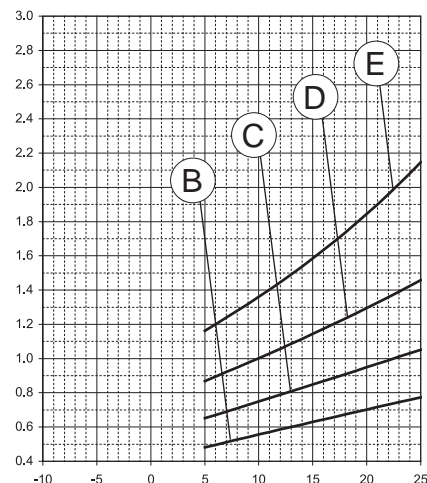

Inlet temperature - source side [°C]

> PERFORMANCES IN COOLING

WATER-WATER HEAT PUMPS

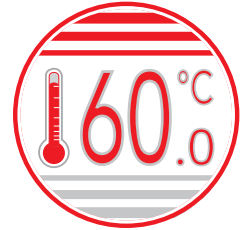

Cooling capacity (brine and water)

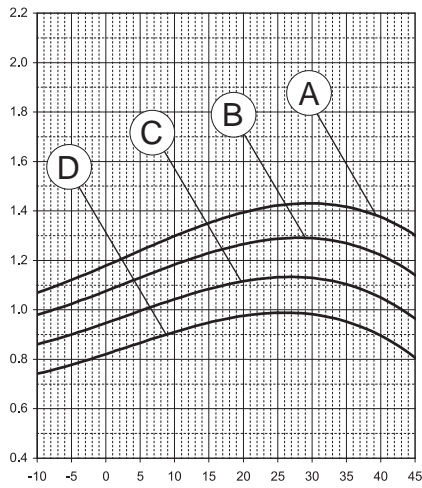

Inlet temperature - source side [°C]

Power input (brine and water)

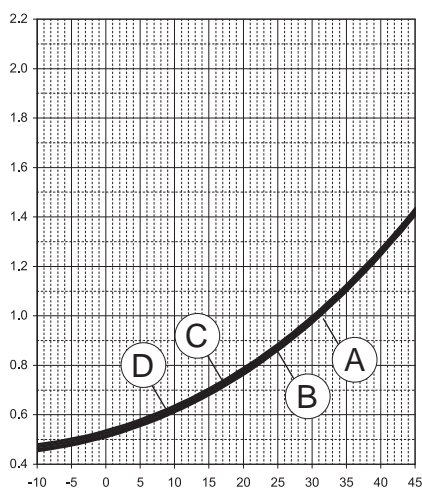

Inlet temperature - source side [°C]

The graphs allow to get the corrective factors to be applied to the nominal performances in order to obtain the real performances in the selected operating conditions.

The reference nominal conditions are :

WATER-WATER units : W30W7

source : water in 30°C out 35°C

plant : water in 12°C out 7°C

BRINE-WATER units : B30W7

source : brine in 30°C out 35°C

plant : water in 12°C out 7°C

Outlet temperature

plant side :

A = 24°C

B = 18°C

C = 12°C

D = 7°C

EER (brine and water)

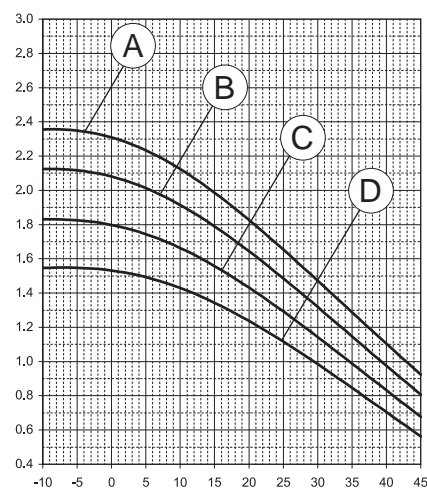

Inlet temperature - source side [°C]

The performances of the units, when used as brine - water, are referred to applications in which the source side fluid is a solution of water and 30% ethylene glycol by volume.

Such a concentration guarantees a freezing temperature of about -15°C and allows the unit to work inside the declared operating limits.

2

5

10

20

MAXIMUM OUTLET WATER TEMPERATURE [°C]

°C

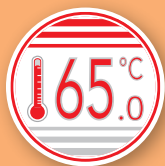

HXP HT

9 - 25

AIR - WATER

Outdoor or indoor installation



RVL-I PLUS

05 - 16T

AIR - WATER

Outdoor installation



HSW LT

3 - 11

WATER - WATER

Outdoor or indoor installation



HXW LT

WATER - WATER

Outdoor or indoor installation

30

50

100

HMP HT

30 - 50

AIR - WATER

Outdoor or indoor installation



HGP HT

60 - 100

AIR - WATER

Indoor installation



HGA HT

60 - 100

AIR - WATER

Outdoor installation



HMW HT

30 - 60

WATER - WATER

Indoor installation



HGW HT

70 - 120

WATER - WATER

Indoor installation



HGP

45 - 95

AIR - WATER

Indoor installation



HGA

45 - 95

AIR - WATER

Outdoor installation



12 - 27



HMW LT

30 - 55

WATER - WATER

Outdoor or indoor installation



> RVL-I PLUS

REVERSIBLE HEAT PUMP FOR OUTDOOR INSTALLATION
WITH DC INVERTER COMPRESSOR

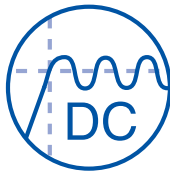

Efficiency class in heating mode - Average climate

Model	5	7	9	12	12T	14	14T	16	16T
Efficiency capacity - medium temperature (water 55°C)	A++	A++	A++	A++	A++	A++	A++	A++	A++
Efficiency capacity - low temperature (water 35°C)	A++	A++	A++	A++	A++	A++	A++	A++	A++

NOTA: Declared according to **European regulation 811/2013**. The values are referred to units without options and accessories.

Unit description

This series of air-water heat pumps meets the needs of winter and summer air conditioning of residential and commercial installations of small and medium power.

All units are suitable for outdoor installation and being able to produce water up to 60 ° C may be employed in systems with radiant floor, fancoils, radiators and for the indirect production of domestic hot water (DHW) via an external boiler (not provided). The units are characterized by the use of a DC inverter compressor that allows you to modulate the capacity from 30 to 120% of the rated capacity and are complete with a hydronic kit including all the essential components for a quick and safe installation.

The units are characterized by high energy efficiency and low noise level and they can be used as the sole generator of the system or integrated with other energy sources such as backup electric heaters or boiler.

All units are supplied with temperature probe (included) for domestic hot water tank (DHW) and with external air temperature probe (already installed on the unit) to realize the climatic control in heating and cooling modes.

All the units are accurately built and individually tested in the factory. The installation only requires the electrical and hydraulic connections.

■ **REFRIGERANT CIRCUIT:** contained in a compartment protected from the air flow to simplify the maintenance operations, is equipped with DC inverter motor driven compressor twin rotary type to ensure greater dynamic balancing and reduce vibrations. It is placed on vibration-damping rubber supports and wrapped by a double layer of sound-absorbing material to reduce the noise. Furthermore, the compressor is equipped with crankcase oil heater. The circuit is equipped with stainless steel brazed plates heat exchanger complete with antifreeze heater, bi-flow electronic expansion valve, 4-way valve, axial fans with brushless DC motor complete with safety protection grilles, finned coil made of copper tubes and aluminium fins. The circuit is controlled by means of temperature probes and pressure transducers and protected by high and low pressure switches.

■ **HYDRAULIC CIRCUIT:** contained in a compartment protected from the air flow to simplify the maintenance operations, is equipped with electronic circulator (brushless DC motor), water flow switch, automatic air vent, water manometer, expansion vessel, safety valve, Y water filter (included). The plate heat exchanger and all the hydraulic pipes are thermally insulated to avoid the formation of condensation and reduce heat loss.

TECHNICAL DATA

Performances data

-	Modelli	5	7	9	10	12	12T	14	14T	16	16T	UM
A7W35	Heating capacity <small>nom</small>	4600	6600	8600	10400	12200	12400	14800	14100	16300	16300	W
		<small>min-max</small> 1341 - 5800	1909 - 7574	2507 - 9500	3032 - 11200	3556 - 12776	3615 - 13697	4314 - 15400	4110 - 16700	4752 - 16730	4752 - 17000	W
	Power input <small>nom</small>	970	1460	2000	2280	2740	2760	3410	3260	3890	3880	W
		<small>min-max</small> 283 - 1280	420 - 1957	580 - 2561	660 - 2605	793 - 2957	803 - 3349	989 - 3747	944 - 4578	1128 - 4584	1125 - 4533	W
	COP	4,72	4,52	4,30	4,57	4,46	4,48	4,34	4,33	4,19	4,20	W/W
	Water flow rate	791	1135	1474	1789	2093	2128	2546	2425	2809	2804	l/h
Available static pressure	61	49	32	53	41	40	25	29	14	15	kPa	
A7W45	Heating capacity <small>nom</small>	4700	6700	9200	10200	12600	12000	14100	14100	16100	16100	W
		<small>min-max</small> 1370 - 5500	1953 - 7700	2682 - 9200	2973 - 10200	3673 - 12600	3498 - 12720	4106 - 14930	4110 - 15200	4693 - 17066	4693 - 16583	W
	Power input <small>nom</small>	1440	2055	2640	3090	3870	3720	4480	4460	5210	5240	W
		<small>min-max</small> 417 - 1833	595 - 2628	764 - 2636	896 - 3377	1121 - 3870	1077 - 4293	1297 - 5166	1293 - 5241	1511 - 6020	1521 - 5888	W
	COP	3,27	3,26	3,49	3,30	3,26	3,23	3,15	3,16	3,09	3,07	W/W
	Water flow rate	808	1152	1577	1754	2164	2067	2425	2425	2773	2762	l/h
Available static pressure	61	48	33	55	39	42	29	29	16	16	kPa	
A35W18	Cooling capacity <small>nom</small>	4550	6450	8350	10300	12200	12600	14600	14000	14800	15100	W
		<small>min-max</small> 1320 - 4921	1872 - 7000	2423 - 9100	2989 - 10800	3541 - 12800	3657 - 12800	4237 - 14800	4063 - 14800	4295 - 15400	4382 - 15400	W
	Power input <small>nom</small>	1000	1470	2100	2070	2650	2740	3320	3260	3650	3780	W
		<small>min-max</small> 304 - 1158	445 - 1719	632 - 2364	628 - 2395	806 - 2943	832 - 2943	1008 - 3515	992 - 3601	1110 - 3990	11470 - 3990	W
	EER	4,55	4,39	3,97	4,98	4,60	4,60	4,40	4,29	4,05	4,00	W/W
	Water flow rate	783	1109	1431	1772	2097	2174	2511	2408	2549	2597	l/h
Available static pressure	61	50	37	55	41	38	26	30	25	23	kPa	
A35W7	Cooling capacity <small>nom</small>	4600	6700	8100	10400	12210	12580	13000	13800	13720	15260	W
		<small>min-max</small> 1479 - 5430	1947 - 7000	2351 - 8300	3018 - 10700	3541 - 12688	3657 - 13003	3773 - 13000	4005 - 13800	3976 - 14317	4440 - 15759	W
	Power input <small>nom</small>	1560	2570	3520	3270	4160	4330	4550	5150	5150	6430	W
		<small>min-max</small> 527 - 2011	773 - 2857	1058 - 3756	994 - 3627	1265 - 4665	1316 - 4603	1386 - 4545	1565 - 5149	1565 - 5544	1953 - 6820	W
	EER	2,95	2,61	2,30	3,18	2,93	2,91	2,86	2,68	2,66	2,38	W/W
	Water flow rate	791	1152	1389	1789	2100	2164	2236	2374	2360	2625	l/h
Available static pressure	61	48	37	53	41	39	36	31	32	22	kPa	

The values are referred to units without options and accessories.

Data declared according to **EN 14511**:

EER (Energy Efficiency Ratio) = ratio of the total cooling capacity to the effective power input of the unit
COP (Coefficient Of Performance) = ratio of the total heating capacity to the effective power input of the unit

A35W7 = source : air in 35°C d.b. / plant : water in 12°C out 7°C

A35W18 = source : air in 35°C d.b. / plant : water in 23°C out 18°C

A7W45 = source : air in 7°C d.b. 6°C w.b. / plant : water in 40°C out 45°C

A7W35 = source : air in 7°C d.b. 6°C w.b. / plant : water in 30°C out 35°C

General data

Models	5	7	9	10	12	12T	14	14T	16	16T	UM
Power supply	230-1-50	230-1-50	230-1-50	230-1-50	230-1-50	400-3-50	230-1-50	400-3-50	230-1-50	400-3-50	V-ph-Hz
Compressor type	Twin Rotary DC										
N° compressors / N° refrigerant circuits	1 / 1										
Plant side heat exchanger type	stainless steel brazed plates										
Source side heat exchanger type	finned coil										
Fans type	DC axial										
N° fans		1					2				n°
Expansion tank volume		2					5				l
Water safety valve set						3					bar
Hydraulic fittings		1" M					1-1/4" M				"
Minimum water content onf the system						20					l
DHW boiler - minimum surface of the coil		1,4					1,7				m²
Refrigerant type	R410A										
Refrigerant charge		2,40					3,60				kg
Control type	Remote wired										
SWL - Sound power level*	63	67	70	68	69	70	73	73	73	75	dB(A)
SPL - Sound pressure level at 1mt**	48	52	55	53	54	55	58	58	58	60	dB(A)
Maximum current input	16	16	20	32	32	16	32	16	32	16	A

* **SWL** = Sound power levels, with reference to 1×10^{-12} W.

** **SPL** = Sound pressure levels, with reference to 2×10^5 Pa.

The Total sound power level in dB(A) measured in compliance with ISO 9614 standards. The Total Sound Power in dB(A) the only binding acoustic specification.

The sound pressure levels are values calculated by applying the ISO-3744 relation.

OPERATING LIMITS

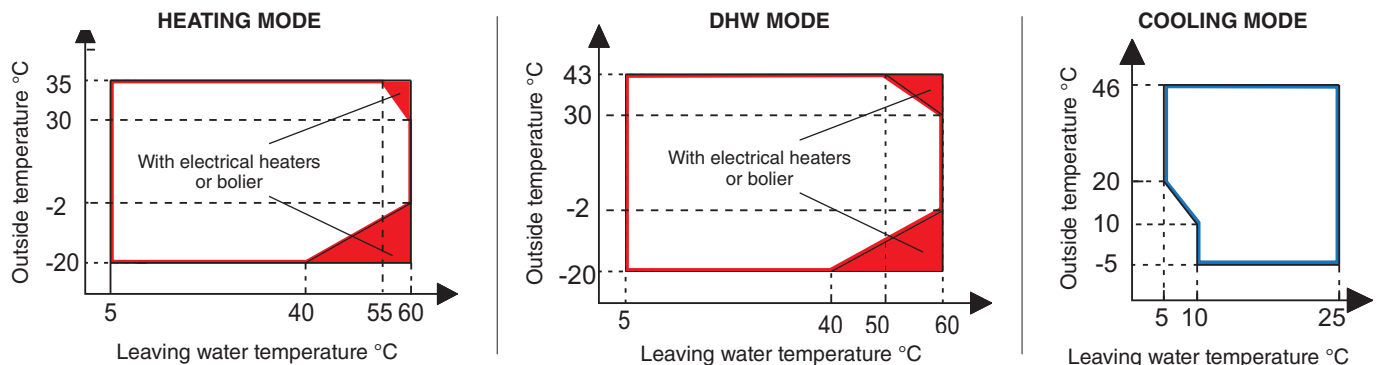

NOTE FOR DHW MODE: leaving water temperature is the temperature of the water produced by the unit and not the DHW temperature available to the user: the DHW

DIMENSIONS

Base version

Mod. 5 - 7 - 9

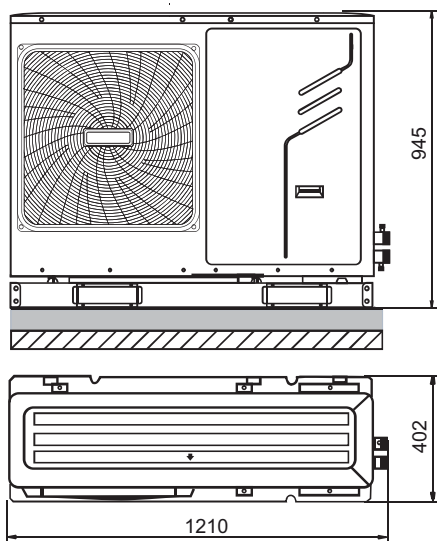

Mod. 12 - 12T - 14 - 14T - 16 - 16T

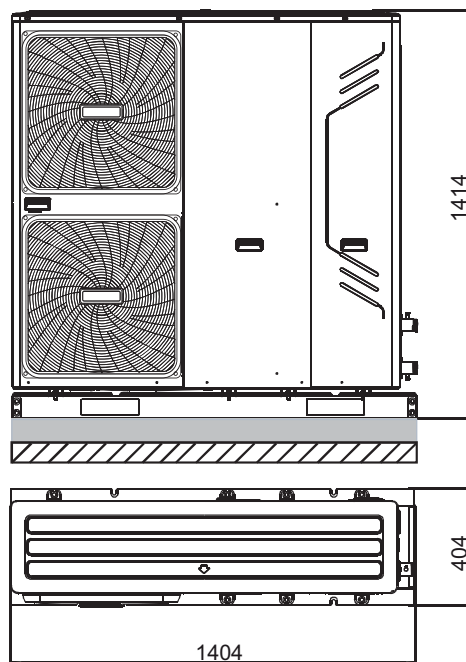

Models	5	7	9	12	12T	14	14T	16	16T		
Packaging (WxHxD)	1500x1140x450				1475x1580x440						mm
Weight Net \ Gross	99 / 117	99 / 117	99 / 117	162 / 178	177 / 193	162 / 178	177 / 193	162 / 178	177 / 193	kg	

Base version + "INERTIAL WATER TANK" accessory

Note: Base version and inertial water tank accessory are provided separately.

Mod. 5 - 7 - 9

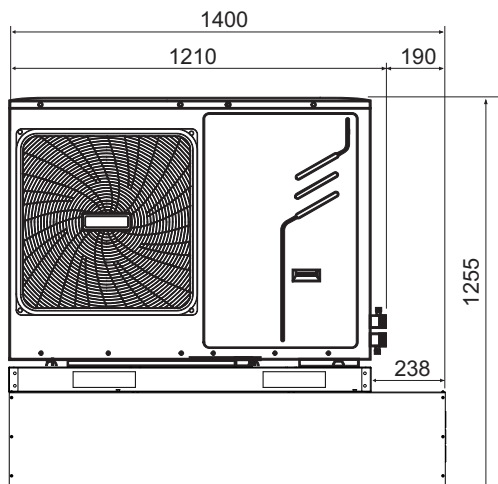

Mod. 12 - 12T - 14 - 14T - 16 - 16T

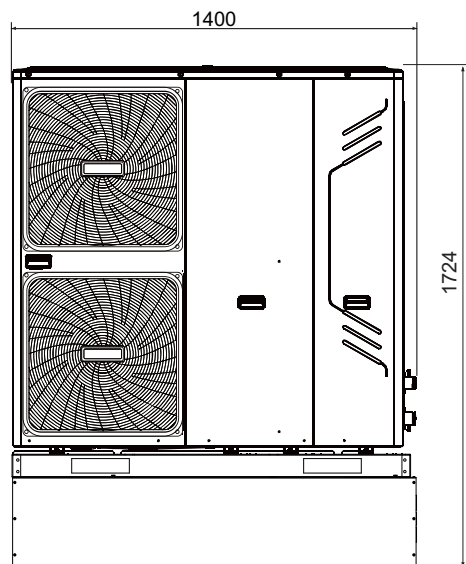

MINIMUM OPERATING AREA

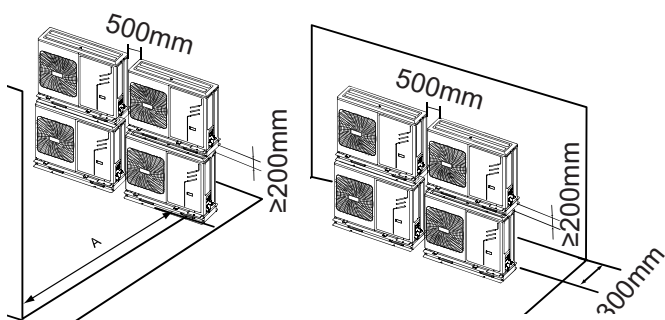

Models	5 - 7 - 9	12 - 12T - 14 - 14T - 16 - 16T	
A	1000	1500	mm

THE CONTROL SYSTEM

The user interface consists of a wired remote controller (up to 50 m from the unit) which allows the management of:

- **HEATING AND COOLING SYSTEM**, where the heat pump is the sole energy source. The unit, if activated in heat or cool mode, works by modulating the frequency of the compressor to maintain the temperature of the produced water to the setpoint value set by the controller. Through parameter you can use the remote controller (eg. For single-zone systems) as a room thermostat.

- **DOMESTIC HOT WATER PRODUCTION (DHW)**. The unit is activated in a heatt mode to keep the temperature of a DHW tank (not supplied) to the setpoint value. It requires a 3-way diverter valve (not supplied) and a temperature sensor (T5 probe, L = 10m, provided) to be inserted into one well of the DHW tank.

- **ADDITIONAL SOURCES OF ENERGY** (boiler or electrical heater). Depending on the parameters set, these sources can be activated in integration or replacement of the heat pump when the system is used for space heating or for DHW production.

The controller also activate additional energy sources in case the heat pump is not working.

- **ELECTRIC HEATER OF THE DHW TANK**. The controller can manage the activation of an electric heater inserted in the DHW tank as a heat integration to the heat pump, for disinfecting function, or as a source of energy reserve for DHW production in case the heat pump is not working.

FAST DHW. This function can be activated manually and it allows you to give priority to DHW production by activating all energy sources (heat pumps, electric heaters, boiler) available for DHW heating to bring in the shortest time possible the DHW tank to the setpoint required.

- **DISINFECT FUNCTION**. You can set from the controller weekly cycles for disinfecting the water in the Dhw tank. In order to successfully execute these cycles, the heat pump must be integrated with DHW electric heater or boiler.

- **SILENT MODE**. If active it allows a reduction of the maximum frequency of the compressor and of the fan speed in order to reduce the noise emitted and the power absorbed by the unit. There are 2 levels of silencing. Through time programming, you can define for 2 daily time bands the desired silent level (eg. during the night).

- **ON / OFF** using an external contact. The unit can be turned on and off (eg. thermostat / remote switch) via an external contact: in this case the unit will operate in the mode set by the controller keyboard.

- **HEAT / COOL** via external contacts. The unit can be activated in heat or cool mode via two external contacts (eg. thermostat that manages the heat and cool demand / remote switch).

- **ECO MODE**. For heating mode it is possible to define daily time band and corresponding set point for ECO mode.

- **WEEKLY SCHEDULING**. It allows a scheduling of 6 time bands for each day of the week: for each time band it is possible to define the mode (COOL / HEAT / DHW) and the required setpoint.

- **Antifreeze protection**. Guaranteed for outdoor air temperature down to -20°C, thanks to the management of the electronic board of the unit which allows you to heat water using antifreeze heater (standard on the plate heat exchanger), the heat pump itself working in heating mode and the electric booster (if installed).

- **Detailed alarms diagnostics with alarms history**.

- **Display of all operating parameters**.



ACCESSORIES

Electrical booster (backup heater box). Suitable for indoor installation, is constituted by an electrical heater (3kW, 230V-1-50) mounted inside a painted sheet metal box and complete with electrical control panel. The booster is then handled by the heat pump to integrate / replace in heating mode the hot water production in case the heat pump is stopped for having reached operational limits or for alarm.

Rubber antivibration dampers.

Inertial water tank. It is constituted of a 60-liter tank in painted sheet metal, thermally insulated and placed inside a painted sheet metal box that can be positioned below the unit.

HY 1 - Cooling / heating and DHW production integrated with boiler heating only

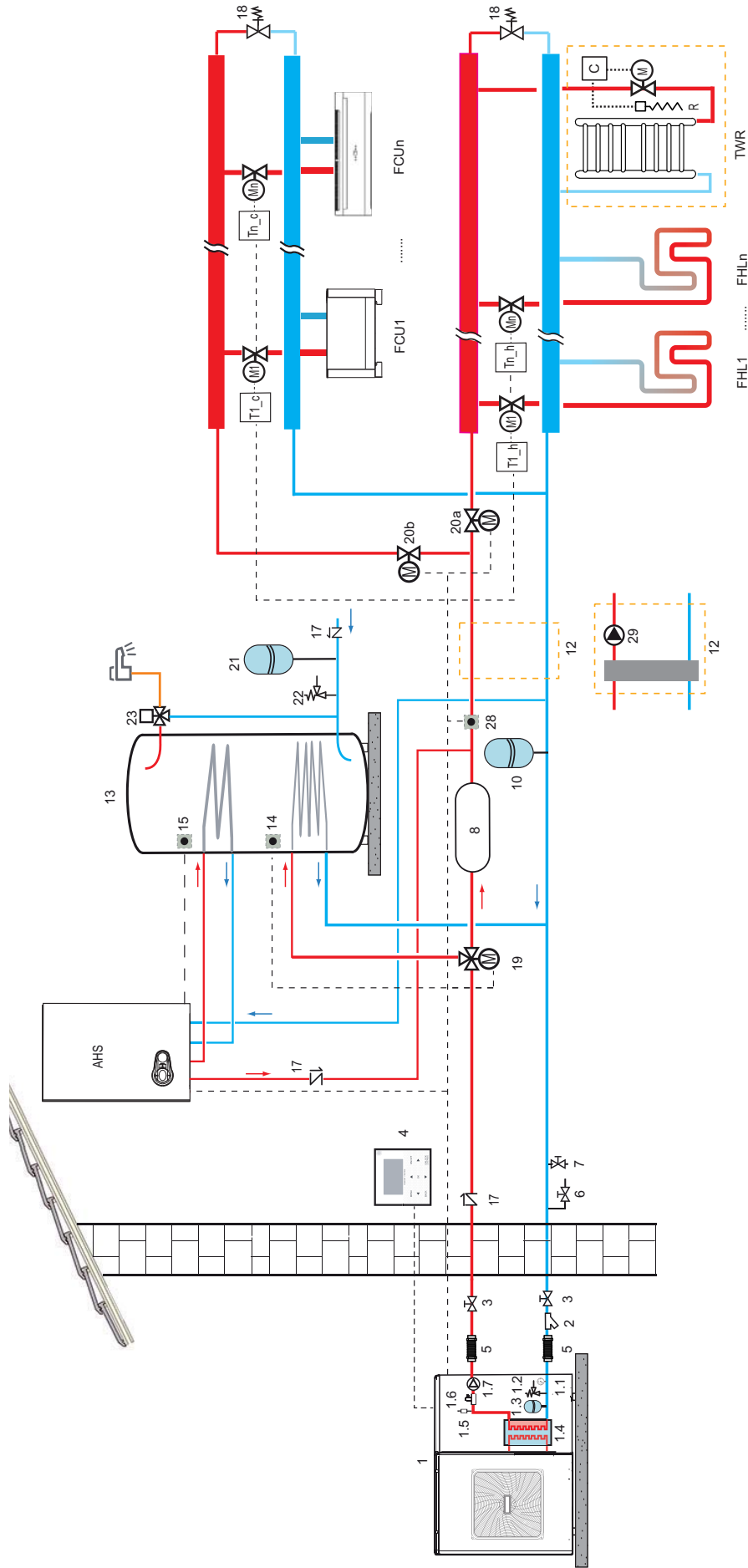

LEGEND

- 1 Heat pump
- 1.1 Manometer
- 1.2 Water safety valve
- 1.3 Expansion Vessel
- 1.4 Plate Heat Exchanger (complete with antifreeze electric heater)
- 1.5 Air Purge Valve
- 1.6 Flow Switch
- 1.7 Pump inside the unit (P_i)
- 2 Y-shape water filter (supplied, mounting by the installer)
- 3 Shut-off valve (not supplied)
- 4 Wired remote control (supplied as standard with the unit)
- 5 Flexible joint (not supplied)
- 6 Drain Valve (not supplied)
- 7 Fill Valve (not supplied)
- 8 Buffer Tank (available as accessory): required if you use air terminals for cooling or if the system water content (excluding the content of the unit) is less than 20 liters
- 10 Expansion tank (not supplied)
- 11 Solar expansion tank

- 12 Hydraulic separator and booster pump (not supplied), evaluate the need for installation in case of high water pressure drop in the system.
- 13 DHW boiler (not supplied). Minimum surface of the coil for heat pump (1.4 m² for mod. 5-7, 1.7 m² for mod. 10-14-14T)
- 13.1 Electrical Heater DHW boiler (not supplied)
- 14 Temperature probe T5 (supplied, mounting by the installer)
- 15 Temperature probe (available as accessory of the gas boiler)
- 17 Check-valve (not supplied)
- 18 Bypass valve (not supplied)
- 19 3-way valve SV1 (not supplied)
- 20a 2-way valve (not supplied), controlled by SV2 with denied logic
- 21 DHW Expansion Vessel (not supplied)
- 22 DHW safety valve (not supplied)
- 23 Thermostatic mixing valve (not supplied)
- 24 Solar system control box with its own probes (not supplied)
- 25 Solar panel (not supplied)
- 26 Solar system pump (not supplied)
- 27 Electrical Booster (available as accessory)

- 28 Temperature probe T1B (available as heat pump accessory)
- 29 External pump (P_o), (not supplied), to evaluate possible need for installation according to the plant water pressure drop, managed by the heat pump.
- T1_c - T1_h Room thermostat for cool demand (not supplied)
- T1_h - T1_h-h Room thermostat for heat demand (not supplied)
- FCU 1...n Air terminal: it can be used only for cooling with radiant floor heating or cooling and heating without radiant floor.
- FHL 1...n only heating radiant floor with n areas
- TWR Towel water radiator for bath integration: if connected to the heating system it MUST be integrated with electrical heater (R) activated by the control (C) that at the same time closes the valve (M); if not connected to the system, the heating is granted only by the electrical heater (R) activated via the control (C)
- AHS Additional boiler for heating and DHW integration (with disinfect function for heating only versions)
 - - - electrical connections to the heat pump
 - - - electrical connections to the solar system control box
 - - - connection to the boiler of the DHW boiler water probe (not supplied)

HY 2 - Cooling / heating integrated with instant combi boiler / DHW production with water heater heat pump (wall hung installation) and post-heating with instant combi boiler

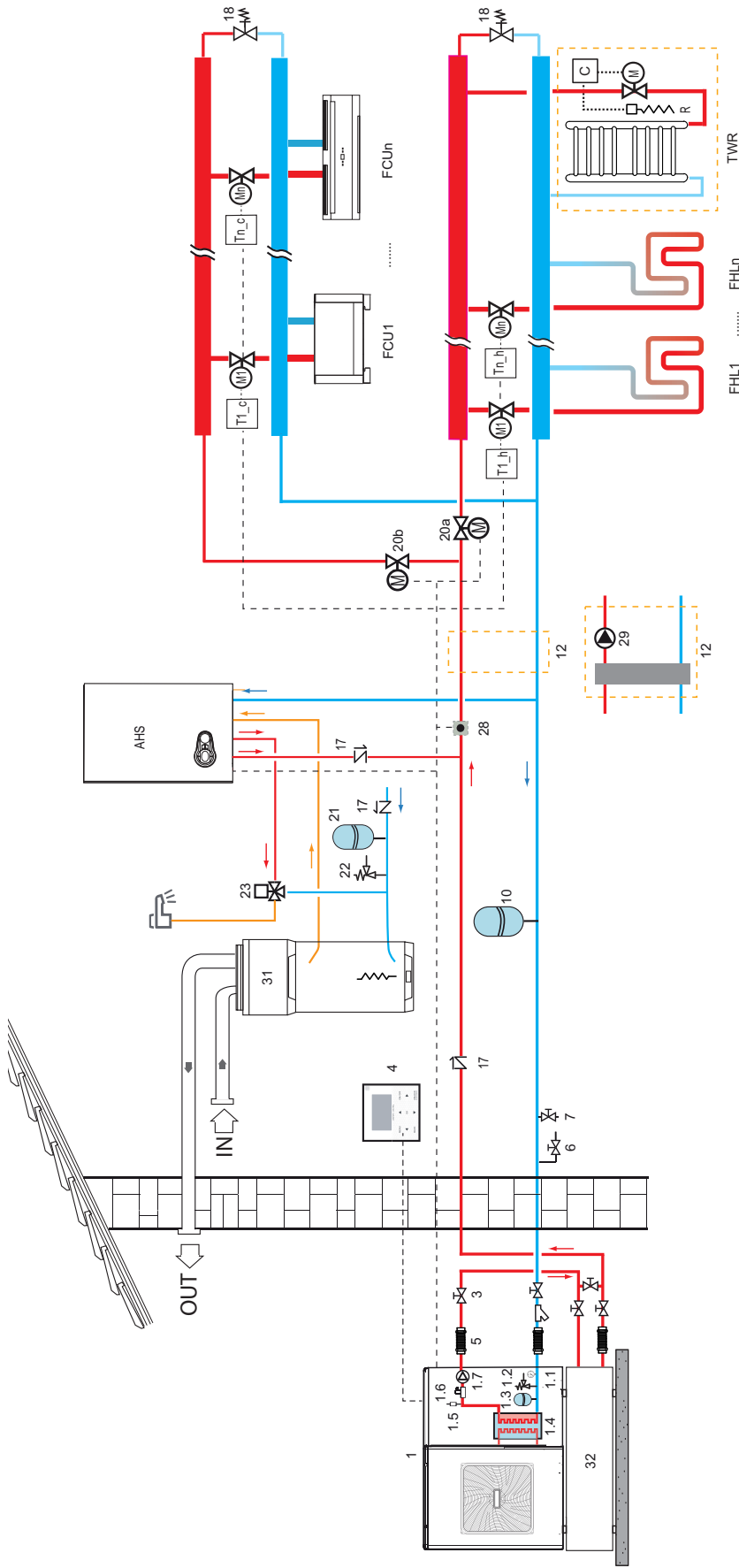

LEGEND

- 1 Heat pump
- 1.1 Manometer
- 1.2 Water safety valve
- 1.3 Expansion Vessel
- 1.4 Plate Heat Exchanger (complete with antifreeze electric heater)
- 1.5 Air Purge Valve
- 1.6 Flow Switch
- 1.7 Pump inside the unit (P_i)
- 2 Y-shape water filter (supplied, mounting by the installer)
- 3 Shut-off valve (not supplied)
- 4 Wired remote control (supplied as standard with the unit)
- 5 Flexible joint (not supplied)
- 6 Drain Valve (not supplied)
- 7 Fill Valve (not supplied)
- 8 Buffer Tank (available as accessory); required if you use air terminals for cooling or if the system water content (excluding the content of the unit) is less than 20 liters
- 10 Expansion tank (not supplied)
- 11 Solar expansion tank
- 12 Hydraulic separator and booster pump (not supplied), evaluate the need for installation in case of high water pressure drop in the system.
- 13 DHW boiler (not supplied), Minimum surface of the coil for heat pump (1,4 m² for mod. 5-7, 1,7 m² for mod. 10-14-14T)
- 13.1 Electrical Heater DHW boiler (not supplied)
- 14 Temperature probe T5 (supplied, mounting by the installer)
- 15 Temperature probe (available as accessory of the gas boiler)
- 17 Check-valve (not supplied)
- 18 Bypass valve (not supplied)
- 19 3-way valve SV1 (not supplied)
- 20a 2-way valve (not supplied), controlled by SV2 with denied logic
- 21 DHW Expansion Vessel (not supplied)
- 22 DHW safety valve (not supplied)
- 23 Thermostatic mixing valve(not supplied)
- 24 Solar system control box with its own probes(not supplied)
- 25 Solar panel (not supplied)
- 26 Solar system pump (not supplied)
- 27 Electrical Booster (available as accessory)
- 28 Temperature probe T1B (available as heat pump accessory)
- 29 External pump (P_o), (not supplied), to evaluate possible need for installation according to the plant water pressure drop, managed by the heat pump.
- T1_c - Tn_c Room thermostat for cool demand (not supplied)
- T1_h - Tn_h Room thermostat for heat demand (not supplied)
- FCU 1...n Air terminal: it can be used only for cooling with radiant floor heating or cooling and heating without radiant floor.
- FHL 1...n only heating radiant floor with n areas
- TWR Towel water radiator for bath integration; if connected to the heating system it MUST be integrated with electrical heater (R) activated by the control (C) that at the same time closes the valve (M); if not connected to the system, the heating is granted only by the electrical heater (R) activated via the control (C)
- AHS Additional boiler for heating and DHW integration (with disinfect function for heating only versions)
 - electrical connections to the heat pump
 - electrical connections to the solar system control box
 - connection to the boiler of the DHW boiler water probe (not supplied)

HY 3S - Cooling / heating integrated with instant combi boiler / DHW production with water heater heat pump (floor installation), integrated with optional solar system and post-heating with instant combi boiler

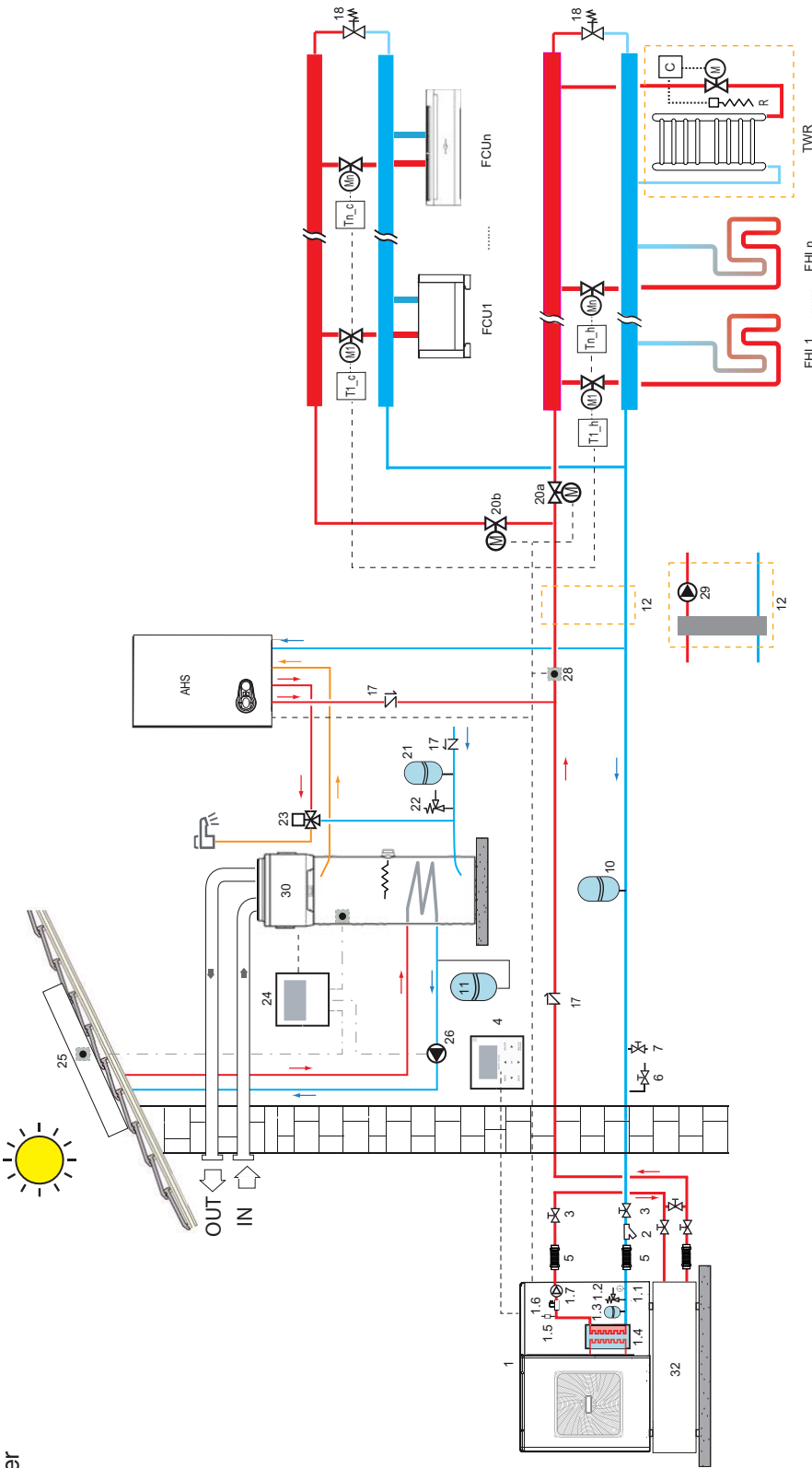

LEGEND

- 1 Heat pump
- 1.1 Manometer
- 1.2 Water safety valve
- 1.3 Expansion Vessel
- 1.4 Plate Heat Exchanger (complete with antifreeze electric heater)
- 1.5 Air Purge Valve
- 1.6 Flow Switch
- 1.7 Pump inside the unit (P_i)
- 2 Y-shape water filter (supplied, mounting by the installer)
- 3 Shut-off valve (not supplied)
- 4 Wired remote control (supplied as standard with the unit)
- 5 Flexible joint (not supplied)
- 6 Drain Valve (not supplied)
- 7 Fill Valve (not supplied)
- 8 Buffer Tank (available as accessory): required if you use air terminals for cooling or if the system water content (excluding the content of the unit) is less than 20 liters
- 10 Expansion tank (not supplied)
- 11 Solar expansion tank
- 12 Hydraulic separator and booster pump (not supplied), evaluate the need for installation in case of high water pressure drop in the system.
- 13 DHW boiler (not supplied). Minimum surface of the coil for heat pump (1.4 m² for mod. 5-7, 1.7 m² for mod. 10-14-14T)
- 13.1 Electrical Heater DHW boiler (not supplied)
- 14 Temperature probe T5 (supplied, mounting by the installer)
- 15 Temperature probe (available as accessory of the gas boiler)
- 17 Check-valve (not supplied)
- 18 Bypass valve (not supplied)
- 19 3-way valve SV1 (not supplied)
- 20a 2-way valve (not supplied), controlled by SV2 with denied logic
- 21 DHW Expansion Vessel (not supplied)
- 22 DHW safety valve (not supplied)
- 23 Thermostatic mixing valve (not supplied)
- 24 Solar system control box with its own probes (not supplied)
- 25 Solar panel (not supplied)
- 26 Solar system pump (not supplied)
- 27 Electrical Booster (available as accessory)
- 28 Temperature probe T1B (available as heat pump accessory)
- 29 External pump (P_o), (not supplied), to evaluate possible need for installation according to the plant water pressure drop, managed by the heat pump.
- T1_c - Tn_c Room thermostat for cool demand (not supplied)
- T1_h - Tn_h Room thermostat for heat demand (not supplied)
- FCU 1...n Air terminal: it can be used only for cooling with radiant floor heating or cooling and heating without radiant floor.
- FHL 1...n only heating radiant floor with n areas
- TWR Towel water radiator for bath integration: if connected to the heating system it MUST be integrated with electrical heater (R) activated by the control (C) that at the same time closes the valve (M); if not connected to the system, the heating is granted only by the electrical heater (R) activated via the control (C)
- AHS Additional boiler for heating and DHW integration (with disinfect function for heating only versions)
 - - - electrical connections to the heat pump
 - - - electrical connections to the solar system control box
 - - - connection to the boiler of the DHW boiler water probe (not supplied)

HY 4S - Cooling / heating integrated with boiler heating only / DHW production with boiler heating only with optional solar system

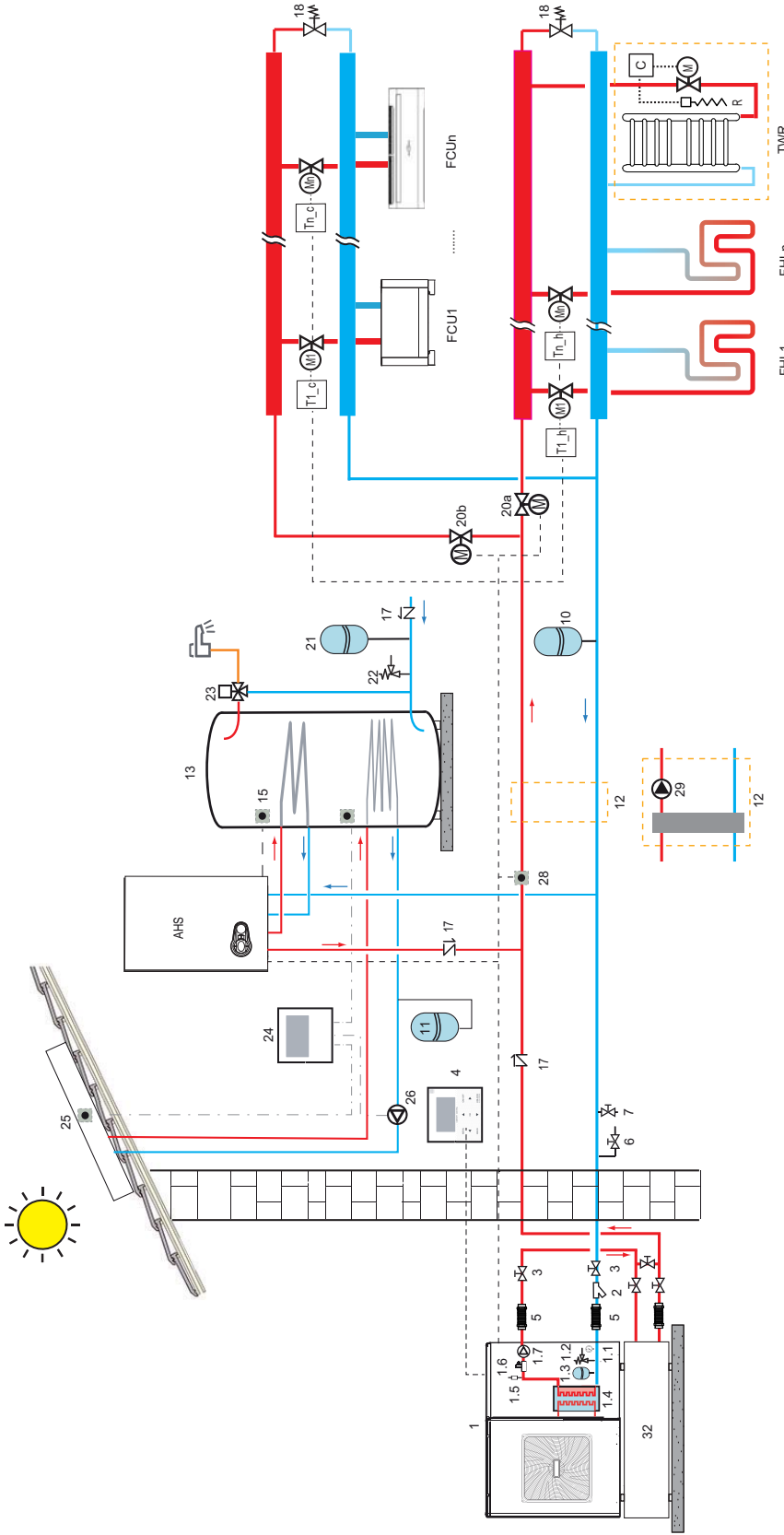

LEGEND

- 1 Heat pump
- 1.1 Manometer
- 1.2 Water safety valve
- 1.3 Expansion Vessel
- 1.4 Plate Heat Exchanger (complete with antifreeze electric heater)
- 1.5 Air Purge Valve
- 1.6 Flow Switch
- 1.7 Pump inside the unit (P_i)
- 2 Y-shape water filter (supplied, mounting by the installer)
- 3 Shut-off valve (not supplied)
- 4 Wired remote control (supplied as standard with the unit)
- 5 Flexible joint (not supplied)
- 6 Drain Valve (not supplied)
- 7 Fill Valve (not supplied)
- 8 Buffer Tank (available as accessory): required if you use air terminals for cooling or if the system water content (excluding the content of the unit) is less than 20 liters
- 10 Expansion tank (not supplied)
- 11 Solar expansion tank

- 12 Hydraulic separator and booster pump (not supplied), evaluate the need for installation in case of high water pressure drop in the system.
- 13 DHW boiler (not supplied), Minimum surface of the coil for heat pump (1,4 m² for mod. 5-7, 1,7 m² for mod. 10-14-14T)
- 13.1 Electrical Heater DHW boiler (not supplied)
- 14 Temperature probe T5 (supplied, mounting by the installer)
- 15 Temperature probe (available as accessory of the gas boiler)
- 17 Check-valve (not supplied)
- 18 Bypass valve (not supplied)
- 19 3-way valve SV1 (not supplied)
- 20 2-way valve (not supplied), controlled by SV2 with denied logic (not supplied), controlled by SV2 with denied logic
- 21 DHW Expansion Vessel (not supplied)
- 22 DHW safety valve (not supplied)
- 23 Thermostatic mixing valve (not supplied)
- 24 Solar system control box with its own probes (not supplied)
- 25 Solar panel (not supplied)
- 26 Solar system pump (not supplied)
- 27 Electrical Booster (available as accessory)

- 28 Temperature probe T1B (available as heat pump accessory)
- 29 External pump (P_o), (not supplied), to evaluate possible need for installation according to the plant water pressure drop, managed by the heat pump.
- T1_c - Tn_c Room thermostat for cool demand (not supplied)
- T1_h - Tn_h Room thermostat for heat demand (not supplied)
- FCU 1...n Air terminal: it can be used only for cooling with radiant floor heating or cooling and heating without radiant floor.
- FHL 1...n only heating radiant floor with n areas
- TWR Towel water radiator for bath integration: if connected to the heating system it MUST be integrated with electrical heater (R) activated by the control (C) that at the same time closes the valve (M); if not connected to the system, the heating is granted only by the electrical heater (R) activated via the control (C)
- AHS Additional boiler for heating and DHW integration (with disinfect function for heating only versions)
 - - - electrical connections to the heat pump
 - - - electrical connections to the solar system control box
 - - - connection to the boiler of the DHW boiler water probe (not supplied)

HY 5S - Cooling / heating integrated with instant combi boiler / DHW production with optional solar system and post-heating with instant combi boiler

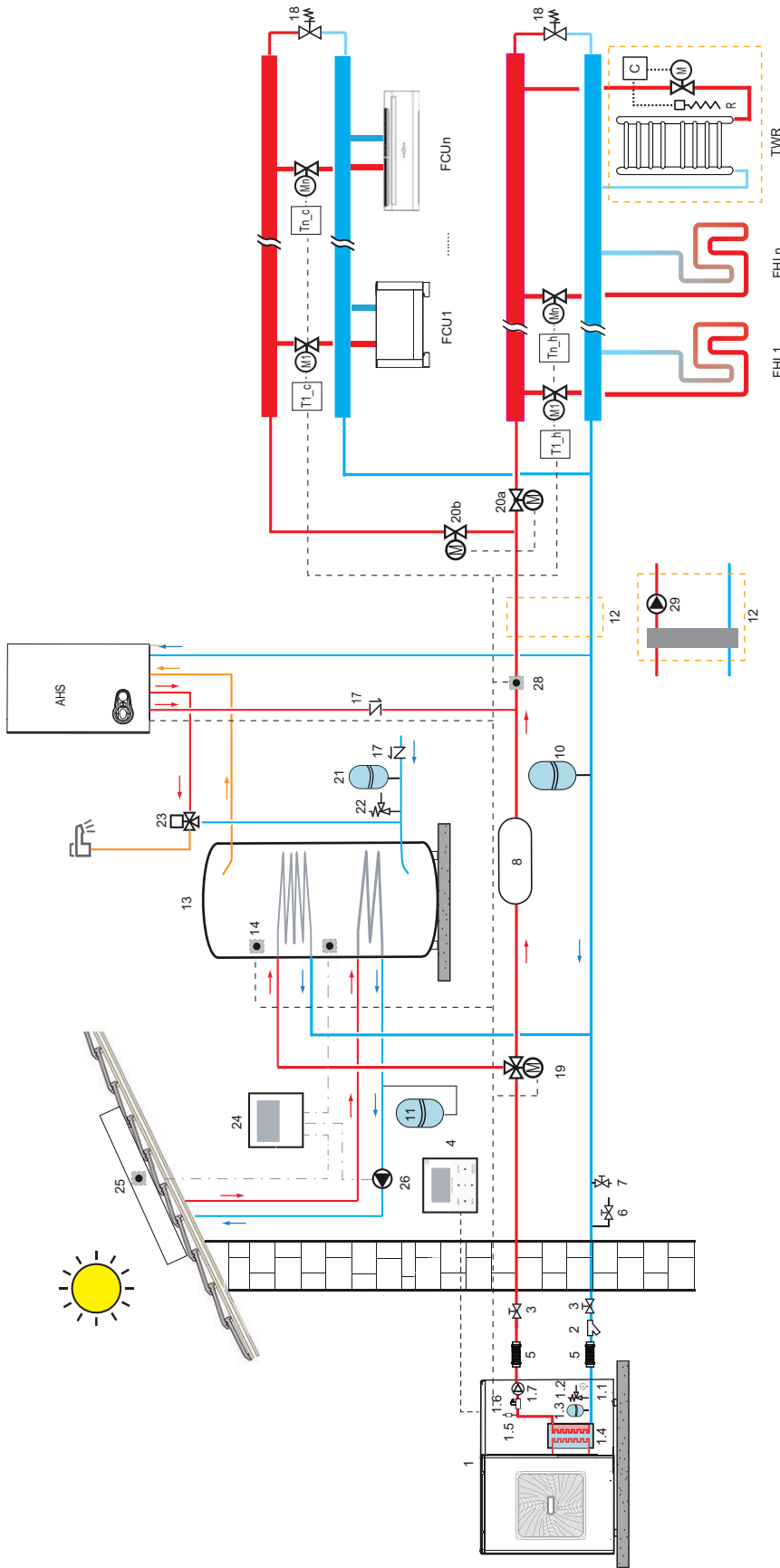

LEGEND

- 1 Heat pump
- 1.1 Manometer
- 1.2 Water safety valve
- 1.3 Expansion Vessel
- 1.4 Plate Heat Exchanger (complete with antifreeze electric heater)
- 1.5 Air Purge Valve
- 1.6 Flow Switch
- 1.7 Pump inside the unit (P_i)
- 2 Y-shape water filter (supplied, mounting by the installer)
- 3 Shut-off valve (not supplied)
- 4 Wired remote control (supplied as standard with the unit)
- 5 Flexible joint (not supplied)
- 6 Drain Valve (not supplied)
- 7 Fill Valve (not supplied)
- 8 Buffer Tank (available as accessory): required if you use air terminals for cooling or if the system water content (excluding the content of the unit) is less than 20 liters
- 10 Expansion tank (not supplied)
- 11 Solar expansion tank

- 12 Hydraulic separator and booster pump (not supplied), evaluate the need for installation in case of high water pressure drop in the system.
- 13 DHW boiler (not supplied). Minimum surface of the coil for heat pump (1,4 m² for mod. 5-7, 1,7 m² for mod. 10-14-14T)
- 13.1 Electrical Heater DHW boiler (not supplied)
- 14 Temperature probe T5 (supplied, mounting by the installer)
- 15 Temperature probe (available as accessory of the gas boiler)
- 17 Check-valve (not supplied)
- 18 Bypass valve (not supplied)
- 19 3-way valve SV1 (not supplied)
- 20a 2-way valve (not supplied), controlled by SV2 with denied logic
- 21 DHW Expansion Vessel (not supplied)
- 22 DHW safety valve (not supplied)
- 23 Thermostatic mixing valve (not supplied)
- 24 Solar system control box with its own probes (not supplied)
- 25 Solar panel (not supplied)
- 26 Solar system pump (not supplied)
- 27 Electrical Booster (available as accessory)

- 28 Temperature probe T1B (available as heat pump accessory)
- 29 External pump (P_o) (not supplied), to evaluate possible need for installation according to the plant water pressure drop, managed by the heat pump.
- T1_c - Tn_c Room thermostat for cool demand (not supplied)
- T1_h - Tn_h Room thermostat for heat demand (not supplied)
- FCU 1...n Air terminal: it can be used only for cooling with radiant floor heating or cooling and heating without radiant floor.
- FHL 1...n only heating radiant floor with n areas
- TWR Towel water radiator for bath integration: if connected to the heating system it MUST be integrated with electrical heater (R) activated by the control (C) that at the same time closes the valve (M); if not connected to the system, the heating is granted only by the electrical heater (R) activated via the control (C)
- AHS Additional boiler for heating and DHW integration (with disinfect function for heating only versions)
 - - - electrical connections to the heat pump
 - - - electrical connections to the solar system control box
 - - - connection to the boiler of the DHW boiler water probe (not supplied)

HY 6 - Cooling / heating integrated with boiler heating only / DHW production with water heater heat pump (floor installation), integrated with boiler heating only

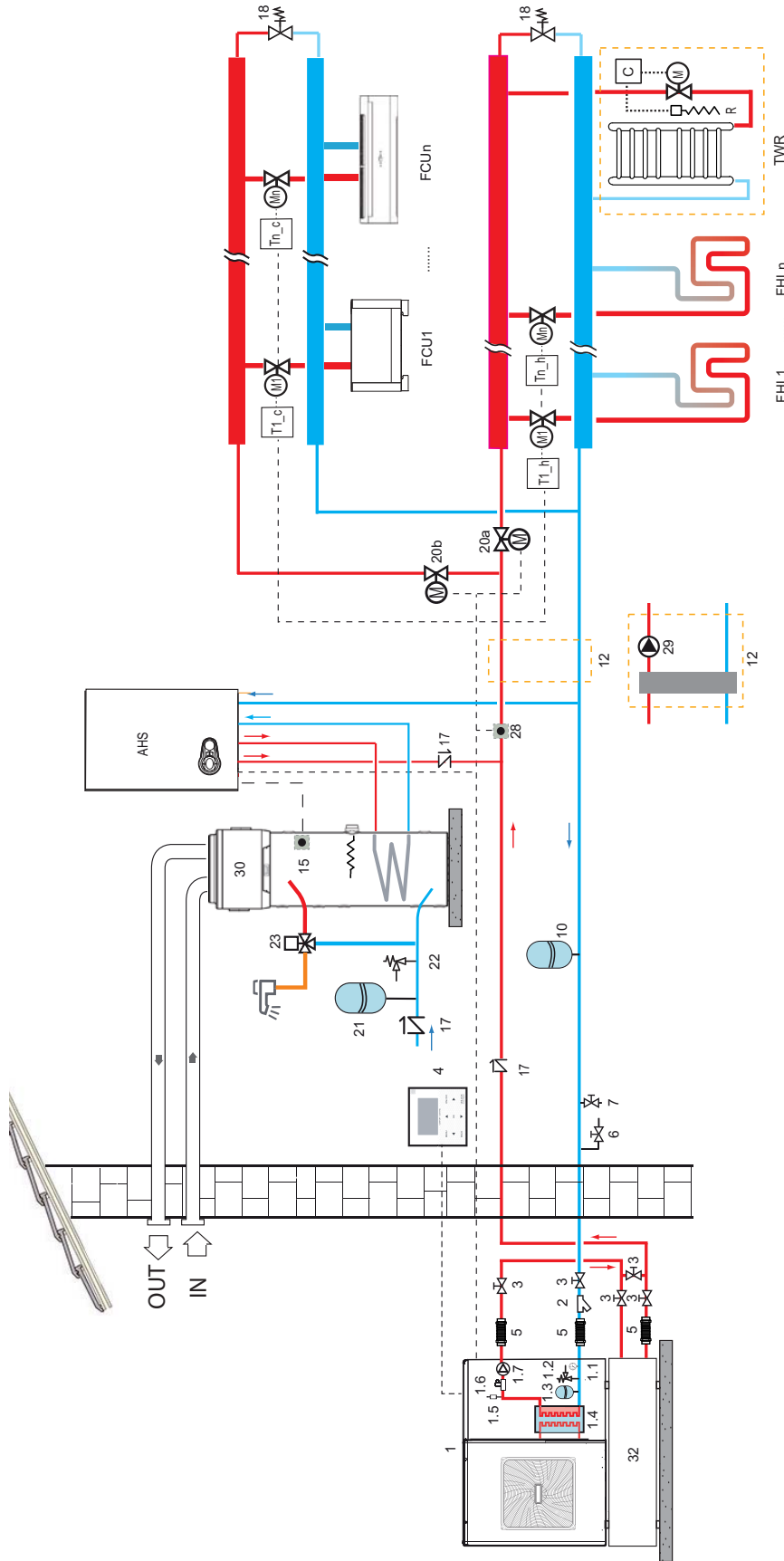

LEGEND

- 1 Heat pump
- 1.1 Manometer
- 1.2 Water safety valve
- 1.3 Expansion Vessel
- 1.4 Plate Heat Exchanger (complete with antifreeze electric heater)
- 1.5 Air Purge Valve
- 1.6 Flow Switch
- 1.7 Pump inside the unit (P_i)
- 2 Y-shape water filter (supplied, mounting by the installer)
- 3 Shut-off valve (not supplied)
- 4 Wired remote control (supplied as standard with the unit)
- 5 Flexible joint (not supplied)
- 6 Drain Valve (not supplied)
- 7 Fill Valve (not supplied)
- 8 Buffer Tank (available as accessory): required if you use air terminals for cooling or if the system water content (excluding the content of the unit) is less than 20 liters
- 10 Expansion tank (not supplied)
- 11 Solar expansion tank

- 12 Hydraulic separator and booster pump (not supplied), evaluate the need for installation in case of high water pressure drop in the system.
- 13 DHW boiler (not supplied), Minimum surface of the coil for heat pump (1,4 m² for mod. 5-7, 1,7 m² for mod. 10-14-14T)
- 13.1 Electrical Heater DHW boiler (not supplied)
- 14 Temperature probe T5 (supplied, mounting by the installer)
- 15 Temperature probe (available as accessory of the gas boiler)
- 17 Check-valve (not supplied)
- 18 Bypass valve (not supplied)
- 19 3-way valve SV1 (not supplied)
- 20 2-way valve (not supplied), controlled by SV2 with denied logic
- 20a 2-way valve (not supplied), controlled by SV2 with denied logic
- 21 DHW Expansion Vessel (not supplied)
- 22 DHW safety valve (not supplied)
- 23 Thermostatic mixing valve (not supplied)
- 24 Solar system control box with its own probes (not supplied)
- 25 Solar panel (not supplied)
- 26 Solar system pump (not supplied)
- 27 Electrical Booster (available as accessory)

- 28 Temperature probe T1B (available as heat pump accessory)
- 29 External pump (P_o), (not supplied), to evaluate possible need for installation according to the plant water pressure drop, managed by the heat pump.
- T1_c - Tn_c Room thermostat for cool demand (not supplied)
- T1_h - Tn_h Room thermostat for heat demand (not supplied)
- FCU 1...n Air terminal: it can be used only for cooling with radiant floor heating or cooling and heating without radiant floor.
- FHL 1...n only heating radiant floor with n areas
- TWR Towel water radiator for bath integration: if connected to the heating system it MUST be integrated with electrical heater (R) activated by the control (C) that at the same time closes the valve (M); if not connected to the system, the heating is granted only by the electrical heater (R) activated via the control (C)
- AHS Additional boiler for heating and DHW integration (with disinfect function for heating only versions)
 - - - electrical connections to the heat pump
 - - - electrical connections to the solar system control box
 - - - connection to the boiler of the DHW boiler water probe (not supplied)

> HXP HT

AIR - WATER
HEAT PUMPS
FOR OUTDOOR OR INDOOR INSTALLATION

Available range

Unit type

IP Reversible heat pump
(reversible on the refrigerant side)

Versions (heat recovery)

VB Base version
VD Desuperheater version

Acoustic setting up

AB Base setting up

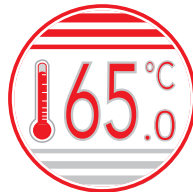

Efficiency class in heating mode - Average climate

Model	9.1	12.1	15.1	20.1	25.1
Efficiency class - medium temperature (water produce at 55°C)	A+	A+	A+	A+	A+
Efficiency class - low temperature (water produce at 35°C)	A+	A+	A+	A+	A+

NOTA: Declared according to **European regulation 811/2013**. The values are referred to units without options and accessories.

Unit description

This series of **air-water** heat pumps satisfies the heating, cooling and domestic hot water production requirements of residential plants of small and medium size.

All the units are suitable both for outdoor or indoor installation. The possibility to produce water at high temperatures makes these units particularly suitable to be applied to **radiators** plants as well as to **fan coil** plants and **radiant** floor plants.

The control system allows to manage not only the refrigerant circuit but the whole plant with the possibility to choose different solutions both for the heating and cooling plant and for the domestic hot water management. The possibility of solar panels or other heating sources integration is also available.

The **heating** function optimizes the flow water temperature according both to the ambient temperature and to the outdoor temperature through climatic curves adaptable to the building features. It's possible to manage a storage tank and two independent circuits (a direct one and a mixed one).

The **domestic hot water** management allows to control the three way valve, the storage tank and the anti-legionella cycles (if necessary).

The **cooling** function can be realized through "active cooling" (refrigerant circuit inversion). When the unit is used in radiant floor plants, to avoid condensate generation, a room humidity sensor can be installed. During cooling mode operation a

part of the heating power in excess can be recovered for the domestic hot water production (VD version).

The **internal programmer clock** allows to define different daily switching programs for heating, cooling and domestic hot water production.

The refrigerant circuit, contained in a box repaired from the air flow to simplify the maintenance operations, is equipped with scroll compressor mounted on damper supports, brazed plate heat exchangers, electronic expansion valve, reverse cycle valve, centrifugal fan (plug fan), finned coil realized with copper pipes and aluminium fins. The circuit is protected by high and low pressure switches and flow switches on the plate heat exchanger.

The compressor is equipped with vapour and liquid injection and is placed on an economized refrigerant circuit with plate heat exchanger and electronic expansion valve dedicated to the injection.

The plate heat exchanger and all the hydraulic pipes are thermally insulated in order to avoid condensate generation and reduce thermal losses.

The plug fan with electronic control of the rotational speed guarantees high efficiencies and low noise in all the operating conditions and allows to install the unit both outdoor (with protection caps) or indoor (with ducted air inlet and outlet). It is moreover possible to reduce the noise during the night.

All the units with three-phase power supply are provided with a phase sequence and correct sequence controller device and

with an outdoor temperature sensor in order to realize the climatic control.

All the units are accurately built and individually tested in the factory. Only electric and hydraulic connections are required for installation.

Options

Plant side flow rate management

- not present
- standard pump
- high head pump
- modulating pump

Domestic hot water production

- not present
- 3 way valve

Integrative electrical heaters

- not present
- standard in the flow

Soft starter

- not present
- standard

Accessories

Rubber vibration dampers

Adjustable rubber vibration dampers

Spring vibration dampers

Protection caps

Remote thermostat (wired or wireless)

Remote control (wired or wireless)

Wireless transmitter

Wireless repeater

Condensate sensor

Room hygrostat

Room humidity sensor

CONTROL SYSTEM

The microprocessor controller is able to manage not only the unit itself but also all that components of the plant which allow to realize a complete system.

The main **functions** of the control system are :

- room temperature control according to the outdoor temperature (climatic control)
- domestic hot water production (management of 3 way valve, storage tank, anti legionella cycles...)
- management of a heating and/or cooling mixed circuit (pump and 3 way mixing valve)
- management of a heating direct circuit (only pump)
- management of a storage tank for heating and/or cooling
- management of electrical heaters for heating and domestic hot water (3 steps logic)
- solar panels integration
- room humidity control for cooling with radiant systems
- internal programmer clock (for heating, cooling and domestic hot water)
- digital input for electrical energy low tariff
- alarm memory management and diagnostic
- compressor and pump operating hour counter
- possibility to manage more units in cascade (maximum 16)

Besides the standard user interface to be placed indoor, wired or wireless remote thermostats are available which allow to control all the operating parameters of the unit and to acquire the temperature in the different zones in order to realize a more precise and comfortable control.

The unit controller is able to manage a lot of different plant solutions enabling automatically the necessary control algorithms according to the components which have been connected.

The management of such components is possible through additional expansion modules which communicate with the unit by means of an internal bus and provide all the inputs and outputs required to fulfil a complete system.

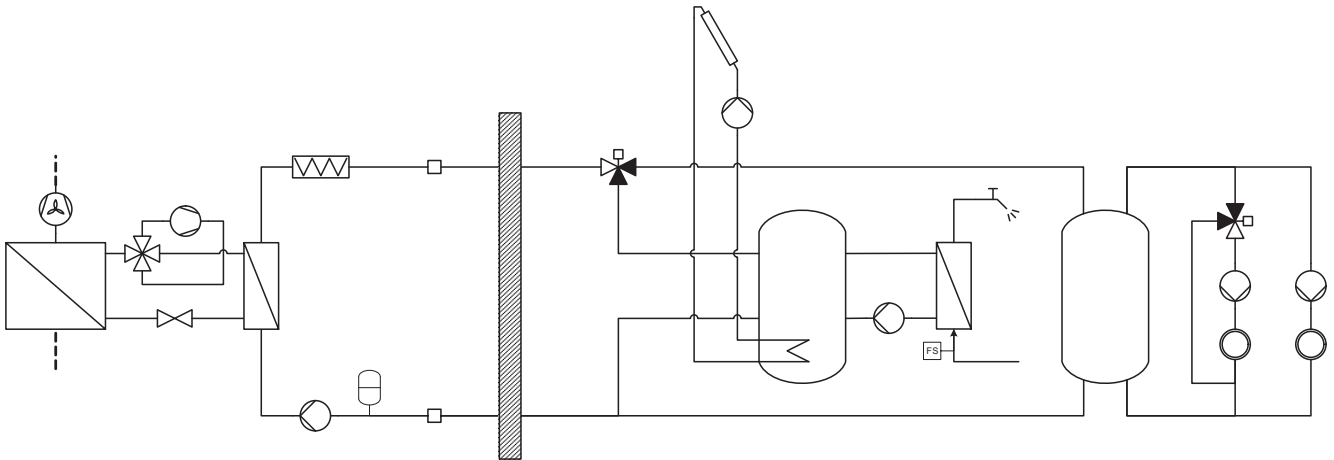
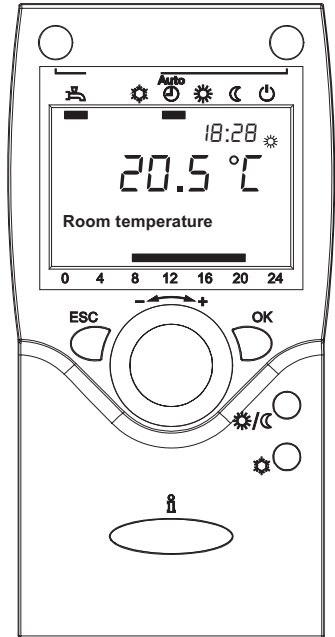

The controller is able to manage up to **two zones in heating** (one by means of a mixed circuit and the other by means of a direct circuit) and **one zone in cooling** (by means of a mixed circuit).

It's possible to realize more complex plants connecting to the heat pump controller further expansion modules in order to extend without limits the number of zones to be managed.

For each zone the following parameters can be set :

- set point
- daily or weekly operating time table
- climatic control curve
- room control sensor : it can be in common with the other zones or independent (in that case it's necessary to install an additional room thermostat)

AERAUIC performances	9.1	12.1	15.1	20.1	25.1	
Nominal air flow rate	3650	4150	4150	7150	7150	m ³ /h
Nominal available static head	30	30	30	50	50	Pa

OPERATING LIMITS	Unit type	Cooling		Heating		
		min	max	min	max	
Outdoor air inlet temperature	IP	5	50	-22	42	°C
Water outlet temperature	IP	6	25	30	65 *	°C

* The maximum water outlet temperature can be increased up to 70°C keeping a ΔT between inlet and outlet equal to 10°C.

NOMINAL performances - Radiant plants

IP	Acoustic setting up : AB	9.1	12.1	15.1	20.1	25.1	
A7W35	Heating capacity	8,82	11,8	15,3	19,8	25,0	kW
	Power input	1,92	2,58	3,32	4,33	5,49	kW
	COP	4,59	4,57	4,61	4,57	4,55	-
	Water flow rate plant side	1524	2043	2632	3429	4312	l/h
	Pressure drops plant side	14	16	24	16	24	kPa
A2W35	Heating capacity	7,45	10,0	12,8	16,7	21,1	kW
	Power input	1,92	2,58	3,32	4,33	5,48	kW
	COP	3,88	3,87	3,86	3,86	3,85	-
	Water flow rate plant side	1288	1727	2217	2892	3637	l/h
	Pressure drops plant side	10	12	18	11	17	kPa
A35W18	Cooling capacity	9,03	12,1	15,5	20,2	25,5	kW
	Power input	2,36	3,16	4,07	5,31	6,71	kW
	EER	3,83	3,83	3,81	3,80	3,80	-
	Water flow rate plant side	1560	2086	2690	3500	4414	l/h
	Pressure drops plant side	14	16	25	16	25	kPa

NOMINAL performances - Standard plants

IP	Acoustic setting up : AB	9.1	12.1	15.1	20.1	25.1	
A7W45	Heating capacity	8,93	11,9	15,4	20,1	25,3	kW
	Power input	2,45	3,30	4,24	5,53	7,01	kW
	COP	3,64	3,61	3,63	3,63	3,61	-
	Water flow rate plant side	1548	2068	2659	3476	4380	l/h
	Pressure drops plant side	14	16	24	16	25	kPa
A2W45	Heating capacity	7,57	10,1	13,0	17,0	21,5	kW
	Power input	2,45	3,30	4,23	5,54	6,99	kW
	COP	3,09	3,06	3,07	3,07	3,08	-
	Water flow rate plant side	1314	1755	2259	2954	3719	l/h
	Pressure drops plant side	11	12	18	12	18	kPa
A35W7	Cooling capacity	6,86	9,19	11,9	15,4	19,4	kW
	Power input	2,18	2,93	3,76	4,91	6,20	kW
	EER	3,15	3,14	3,16	3,14	3,13	-
	Water flow rate plant side	1179	1581	2042	2643	3329	l/h
	Pressure drops plant side	9	10	16	10	15	kPa

NOMINAL performances - HIGH temperature and VERY HIGH temperature plants

IP	Acoustic setting up : AB	9.1	12.1	15.1	20.1	25.1	
A7W65	Heating capacity	9,28	12,4	16,0	20,9	26,3	kW
	Power input	3,76	5,06	6,47	8,49	10,7	kW
	COP	2,47	2,45	2,47	2,46	2,46	-
	Water flow rate plant side	812	1085	1400	1828	2301	l/h
	Pressure drops plant side	5	5	8	5	7	kPa
A2W65	Heating capacity	7,96	10,7	13,7	17,9	22,5	kW
	Power input	3,77	5,06	6,48	8,51	10,7	kW
	COP	2,11	2,11	2,11	2,10	2,10	-
	Water flow rate plant side	696	936	1199	1566	1968	l/h
	Pressure drops plant side	4	4	6	4	5	kPa
A7W55	Heating capacity	9,08	12,2	15,6	20,4	25,7	kW
	Power input	3,02	4,05	5,19	6,80	8,57	kW
	COP	3,01	3,01	3,01	3,00	3,00	-
	Water flow rate plant side	988	1329	1700	2223	2800	l/h
	Pressure drops plant side	7	8	11	7	11	kPa
A2W55	Heating capacity	7,73	10,4	13,3	17,4	21,9	kW
	Power input	3,02	4,07	5,19	6,82	8,59	kW
	COP	2,56	2,56	2,56	2,55	2,55	-
	Water flow rate plant side	842	1133	1449	1896	2386	l/h
	Pressure drops plant side	5	6	9	5	8	kPa

Data declared according to **EN 14511**. The values are referred to units without options and accessories.

A7W65 = source : air in 7°C d.b. 6°C w.b. / plant : water in 55°C out 65°C
 A7W55 = source : air in 7°C d.b. 6°C w.b. / plant : water in 47°C out 55°C
 A7W45 = source : air in 7°C d.b. 6°C w.b. / plant : water in 40°C out 45°C
 A7W35 = source : air in 7°C d.b. 6°C w.b. / plant : water in 30°C out 35°C
 A35W7 = source : air in 35°C d.b. / plant : water in 12°C out 7°C
 A35W18 = source : air in 35°C d.b. / plant : water in 23°C out 18°C

A2W65 = source : air in 2°C d.b. 1°C w.b. / plant : water in 55°C out 65°C
 A2W55 = source : air in 2°C d.b. 1°C w.b. / plant : water in 47°C out 55°C
 A2W45 = source : air in 2°C d.b. 1°C w.b. / plant : water in 40°C out 45°C
 A2W35 = source : air in 2°C d.b. 1°C w.b. / plant : water in 30°C out 35°C

TECHNICAL DATA	9.1	12.1	15.1	20.1	25.1	
Power supply	230 - 1 - 50 400 - 3N - 50			400 - 3N - 50		V-ph-Hz
Compressor type	scroll with vapour injection (EVI)					-
N° compressors / N° refrigerant circuits	1 / 1					n°
Plant side heat exchanger type	stainless steel brazed plates					-
Source side heat exchanger type	finned coil					-
Fans type	plug fan					-
N° fans	1					n°
Hydraulic fittings	1" M			1"1/4 M		-
Hydraulic fittings heat recovery (VD)	1" M			1" M		-
Weight *	213	220	225	287	295	kg
Maximum power input *	4,5	5,9	7,1	10,1	12,5	kW

* base unit without options and accessories

ACOUSTIC PERFORMANCES

Unit without accessory "Protection caps"	9.1	12.1	15.1	20.1	25.1	
Sound power level	71	72	72	74	74	dB(A)
Sound pressure level at 1 metre	55	56	57	59	59	dB(A)
Sound pressure level at 5 metres	45	46	46	48	48	dB(A)
Sound pressure level at 10 metres	39	40	41	43	43	dB(A)
Unit with accessory "Protection caps"	9.1	12.1	15.1	20.1	25.1	
Sound power level	67	68	69	71	71	dB(A)
Sound pressure level at 1 metre	52	53	54	55	55	dB(A)
Sound pressure level at 5 metres	41	42	43	45	45	dB(A)
Sound pressure level at 10 metres	36	37	38	40	40	dB(A)

The acoustic performances are referred to units operating in heating mode at nominal conditions A7W35.

Unit placed in free field on reflecting surface (directional factor equal to 2).

The sound power level is measured according to ISO 3744 standard.

The sound pressure level is calculated according to ISO 3744 and is referred to a distance of 1/5/10 metres from the external surface of the unit.

DIMENSIONS AND MINIMUM OPERATING AREA

Respect the free area around the unit as shown in figure in order to guarantee a good accessibility and facilitate maintenance and control operations.

C	600 mm
D	600 mm

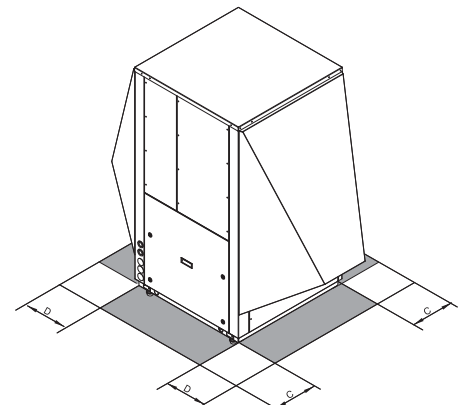
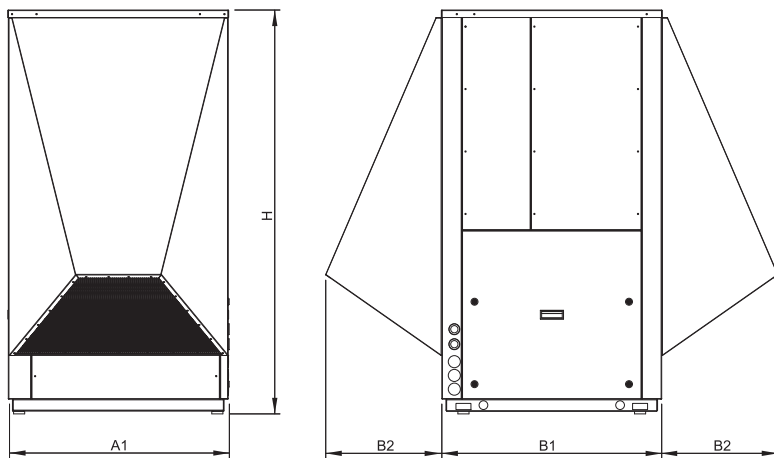

Outdoor installation

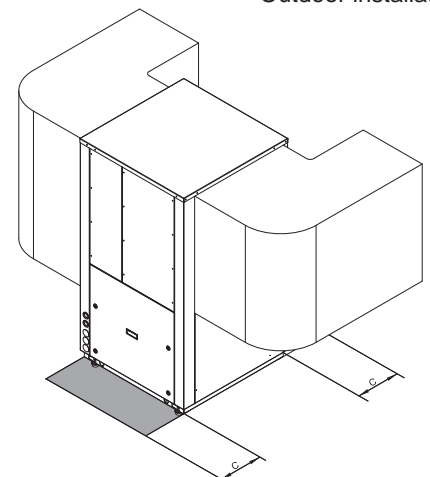

Indoor installation

	9.1 - 12.1 - 15.1	20.1 - 25.1	
A1	730	880	mm
B1	730	880	mm
B2	450	465	mm
H	1470	1620	mm

> HMP HT

AIR - WATER
HEAT PUMPS
FOR OUTDOOR OR INDOOR INSTALLATION

Available range

Unit type

IP Reversible heat pump
(reversible on the refrigerant side)

Versions (heat recovery)

VB Base version
VD Desuperheater version

Acoustic setting up

AB Base setting up

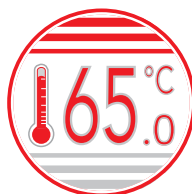

Efficiency class in heating mode - Average climate

Modello	30.1	35.1	40.1	45.1	50.1
Efficiency class - medium temperature (water produce at 55°C)	A+	A+	A+	A+	A+
Efficiency class - low temperature (water produce at 35°C)	A+	A+	A+	A+	A+

NOTA: Declared according to **European regulation 811/2013**. The values are referred to units without options and accessories.

Unit description

This series of **air-water** heat pumps satisfies the heating, cooling and domestic hot water production requirements of residential plants of small and medium size.

All the units are suitable both for outdoor or indoor installation. The possibility to produce water at high temperatures makes these units particularly suitable to be applied to **radiators** plants as well as to **fan coil** plants and **radiant** floor plants.

The control system allows to manage not only the refrigerant circuit but the whole plant with the possibility to choose different solutions both for the heating and cooling plant and for the domestic hot water management. The possibility of solar panels or other heating sources integration is also available.

The **heating** function optimizes the flow water temperature according both to the ambient temperature and to the outdoor temperature through climatic curves adaptable to the building features. It's possible to manage a storage tank and two independent circuits (a direct one and a mixed one).

The **domestic hot water** management allows to control the three way valve, the storage tank and the anti-legionella cycles (if necessary).

The **cooling** function can be realized through "active cooling" (refrigerant circuit inversion). When the unit is used in radiant floor plants, to avoid condensate generation, a room humidity sensor can be installed. During cooling mode operation a

part of the heating power in excess can be recovered for the domestic hot water production (VD version).

The **internal programmer clock** allows to define different daily switching programs for heating, cooling and domestic hot water production.

The refrigerant circuit, contained in a box repaired from the air flow to simplify the maintenance operations, is equipped with scroll compressor mounted on damper supports, brazed plate heat exchangers, electronic expansion valve, reverse cycle valve, centrifugal fan (plug fan), finned coil realized with copper pipes and aluminium fins. The circuit is protected by high and low pressure switches and flow switches on the plate heat exchanger.

The compressor is equipped with vapour and liquid injection and is placed on an economized refrigerant circuit with plate heat exchanger and electronic expansion valve dedicated to the injection.

The plate heat exchanger and all the hydraulic pipes are thermally insulated in order to avoid condensate generation and reduce thermal losses.

The plug fan with electronic control of the rotational speed guarantees high efficiencies and low noise in all the operating conditions and allows to install the unit both outdoor (with protection caps) or indoor (with ducted air inlet and outlet). It is moreover possible to reduce the noise during the night.

All the units with three-phase power supply are provided with a phase sequence and correct sequence controller device and

with an outdoor temperature sensor in order to realize the climatic control.

All the units are accurately built and individually tested in the factory. Only electric and hydraulic connections are required for installation.

Options

Plant side flow rate management

- not present
- standard pump
- high head pump
- modulating pump

Domestic hot water production

- not present
- 3 way valve

Integrative electrical heaters

- not present
- standard in the flow

Soft starter

- not present
- standard

Accessories

- Rubber vibration dampers
- Adjustable rubber vibration dampers
- Spring vibration dampers
- Protection caps
- Remote thermostat (wired or wireless)
- Remote control (wired or wireless)
- Wireless transmitter
- Wireless repeater
- Condensate sensor
- Room hygostat
- Room humidity sensor

CONTROL SYSTEM

The microprocessor controller is able to manage not only the unit itself but also all that components of the plant which allow to realize a complete system.

The main **functions** of the control system are :

- room temperature control according to the outdoor temperature (climatic control)
- domestic hot water production (management of 3 way valve, storage tank, anti legionella cycles...)
- management of a heating and/or cooling mixed circuit (pump and 3 way mixing valve)
- management of a heating direct circuit (only pump)
- management of a storage tank for heating and/or cooling
- management of electrical heaters for heating and domestic hot water (3 steps logic)
- solar panels integration
- room humidity control for cooling with radiant systems
- internal programmer clock (for heating, cooling and domestic hot water)
- digital input for electrical energy low tariff
- alarm memory management and diagnostic
- compressor and pump operating hour counter
- possibility to manage more units in cascade (maximum 16)

Besides the standard user interface to be placed indoor, wired or wireless remote thermostats are available which allow to control all the operating parameters of the unit and to acquire the temperature in the different zones in order to realize a more precise and comfortable control.

The unit controller is able to manage a lot of different plant solutions enabling automatically the necessary control algorithms according to the components which have been connected.

The management of such components is possible through additional expansion modules which communicate with the unit by means of an internal bus and provide all the inputs and outputs required to fulfil a complete system.

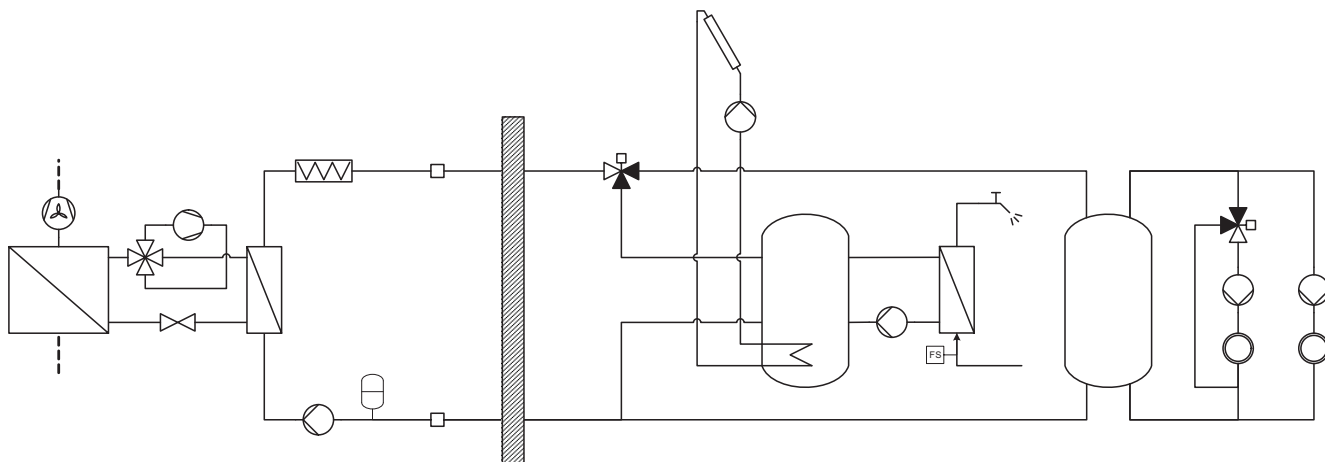
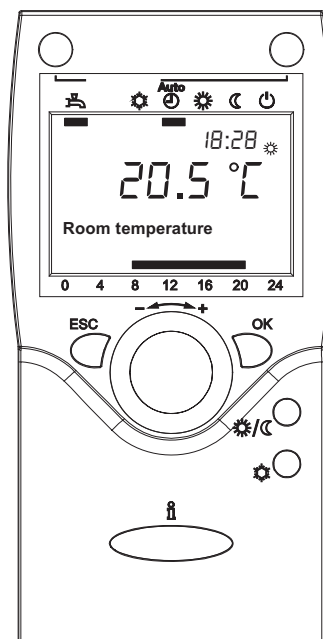

The controller is able to manage up to **two zones in heating** (one by means of a mixed circuit and the other by means of a direct circuit) and **one zone in cooling** (by means of a mixed circuit).

It's possible to realize more complex plants connecting to the heat pump controller further expansion modules in order to extend without limits the number of zones to be managed.

For each zone the following parameters can be set :

- set point
- daily or weekly operating time table
- climatic control curve
- room control sensor : it can be in common with the other zones or independent (in that case it's necessary to install an additional room thermostat)

AERAUIC performances	30.1	35.1	40.1	45.1	50.1	
Nominal air flow rate	7850	7850	7850	11400	11400	m ³ /h
Nominal available static head	50	50	50	150	150	Pa

OPERATING LIMITS	Unit type	Cooling		Heating		
		min	max	min	max	
Outdoor air inlet temperature	IP	5	50	-22	42	°C
Water outlet temperature	IP	6	25	30	65 *	°C

* The maximum water outlet temperature can be increased up to 70°C keeping a ΔT between inlet and outlet equal to 10°C.

NOMINAL performances - Radiant plants

IP	Base acoustic setting up (AB)	30.1	35.1	40.1	45.1	50.1	
A7W35	Heating capacity	29,2	34,4	38,6	44,1	50,4	kW
	Power input	6,32	7,48	8,40	9,59	11,0	kW
	COP	4,62	4,60	4,60	4,60	4,58	-
	Water flow rate plant side	5039	5923	6650	7602	8676	l/h
	Pressure drops plant side	21	28	35	31	40	kPa
A2W35	Heating capacity	24,7	29,0	32,6	37,2	42,5	kW
	Power input	6,32	7,46	8,36	9,55	11,0	kW
	COP	3,91	3,89	3,90	3,90	3,86	-
	Water flow rate plant side	4260	5005	5628	6425	7325	l/h
	Pressure drops plant side	15	21	26	22	29	kPa
A35W18	Cooling capacity	29,8	35,0	39,3	44,9	51,2	kW
	Power input	7,74	9,15	10,2	11,7	13,4	kW
	EER	3,85	3,83	3,85	3,84	3,82	-
	Water flow rate plant side	5155	6069	6811	7776	8880	l/h
	Pressure drops plant side	22	30	37	32	42	kPa

NOMINAL performances - Standard plants

IP	Base acoustic setting up (AB)	30.1	35.1	40.1	45.1	50.1	
A7W45	Heating capacity	29,6	34,8	39,1	44,6	51,0	kW
	Power input	8,07	9,54	10,7	12,2	14,0	kW
	COP	3,67	3,65	3,65	3,66	3,64	-
	Water flow rate plant side	5127	6013	6761	7716	8811	l/h
	Pressure drops plant side	22	29	36	32	41	kPa
A2W45	Heating capacity	25,1	29,5	33,1	37,8	43,2	kW
	Power input	8,06	9,52	10,6	12,2	14,0	kW
	COP	3,11	3,10	3,12	3,10	3,09	-
	Water flow rate plant side	4345	5109	5735	6552	7473	l/h
	Pressure drops plant side	16	21	27	23	30	kPa
A35W7	Cooling capacity	22,7	26,6	29,9	34,1	38,9	kW
	Power input	7,15	8,42	9,44	10,8	12,4	kW
	EER	3,17	3,16	3,17	3,16	3,14	-
	Water flow rate plant side	3896	4582	5148	5869	6710	l/h
	Pressure drops plant side	13	18	22	19	25	kPa

NOMINAL performances - HIGH temperature plants

IP	Base acoustic setting up (AB)	30.1	35.1	40.1	45.1	50.1	
A7W65	Heating capacity	30,7	36,1	40,5	46,3	53,0	kW
	Power input	12,3	14,5	16,2	18,6	21,3	kW
	COP	2,50	2,49	2,50	2,49	2,49	-
	Water flow rate plant side	2686	3158	3543	4051	4628	l/h
	Pressure drops plant side	6	9	11	9	12	kPa
A2W65	Heating capacity	26,3	31,0	34,7	39,7	45,3	kW
	Power input	12,4	14,5	16,2	18,6	21,2	kW
	COP	2,12	2,14	2,14	2,13	2,14	-
	Water flow rate plant side	2301	2712	3036	3473	3963	l/h
	Pressure drops plant side	5	6	8	7	9	kPa
A7W55	Heating capacity	30,0	35,3	39,7	45,4	51,7	kW
	Power input	9,89	11,6	13,1	15,0	17,1	kW
	COP	3,03	3,04	3,03	3,03	3,02	-
	Water flow rate plant side	3269	3846	4315	4936	5623	l/h
	Pressure drops plant side	9	12	15	14	17	kPa
A2W55	Heating capacity	25,6	30,1	33,7	38,6	44,1	kW
	Power input	9,91	11,6	13,0	14,9	17,1	kW
	COP	2,58	2,59	2,59	2,59	2,58	-
	Water flow rate plant side	2789	3280	3672	4206	4794	l/h
	Pressure drops plant side	7	9	11	10	13	kPa

Data declared according to **EN 14511**. The values are referred to units without options and accessories.

A7W65 = source : air in 7°C d.b. 6°C w.b. / plant : water in 55°C out 65°C
 A7W55 = source : air in 7°C d.b. 6°C w.b. / plant : water in 47°C out 55°C
 A7W45 = source : air in 7°C d.b. 6°C w.b. / plant : water in 40°C out 45°C
 A7W35 = source : air in 7°C d.b. 6°C w.b. / plant : water in 30°C out 35°C
 A35W7 = source : air in 35°C d.b. / plant : water in 12°C out 7°C
 A35W18 = source : air in 35°C d.b. / plant : water in 23°C out 18°C

A2W65 = source : air in 2°C d.b. 1°C w.b. / plant : water in 55°C out 65°C
 A2W55 = source : air in 2°C d.b. 1°C w.b. / plant : water in 47°C out 55°C
 A2W45 = source : air in 2°C d.b. 1°C w.b. / plant : water in 40°C out 45°C
 A2W35 = source : air in 2°C d.b. 1°C w.b. / plant : water in 30°C out 35°C

TECHNICAL DATA	30.1	35.1	40.1	45.1	50.1	
Power supply	400 - 3N - 50					V-ph-Hz
Compressor type	scroll with vapour injection (EVI)					-
N° compressors / N° refrigerant circuits	1 / 1					n°
Plant side heat exchanger type	stainless steel brazed plates					-
Source side heat exchanger type	finned coil					-
Fans type	plug fan					-
N° fans	1					n°
Hydraulic fittings	1"1/4 M					-
Hydraulic fittings heat recovery (VD)	1" M					-
Weight *	364	366	369	428	430	kg
Maximum power input *	13,9	15,5	17,1	21,6	24,5	kW

* base unit without options and accessories

ACOUSTIC PERFORMANCES

Unit without accessory "Protection caps"	30.1	35.1	40.1	45.1	50.1	
Sound power level	76	77	77	78	78	dB(A)
Sound pressure level at 1 metre	60	61	61	62	62	dB(A)
Sound pressure level at 5 metres	50	51	51	52	52	dB(A)
Sound pressure level at 10 metres	44	45	45	46	46	dB(A)
Unit with accessory "Protection caps"	30.1	35.1	40.1	45.1	50.1	
Sound power level	72	73	73	74	74	dB(A)
Sound pressure level at 1 metre	56	57	57	58	58	dB(A)
Sound pressure level at 5 metres	46	47	47	48	48	dB(A)
Sound pressure level at 10 metres	41	42	42	43	43	dB(A)

The acoustic performances are referred to units operating in heating mode at nominal conditions A7W35.

Unit placed in free field on reflecting surface (directional factor equal to 2).

The sound power level is measured according to ISO 3744 standard.

The sound pressure level is calculated according to ISO 3744 and is referred to a distance of 1/5/10 metres from the external surface of the unit.

DIMENSIONS AND MINIMUM OPERATING AREA

Respect the free area around the unit as shown in figure in order to guarantee a good accessibility and facilitate maintenance and control operations.

C	600 mm
D	600 mm

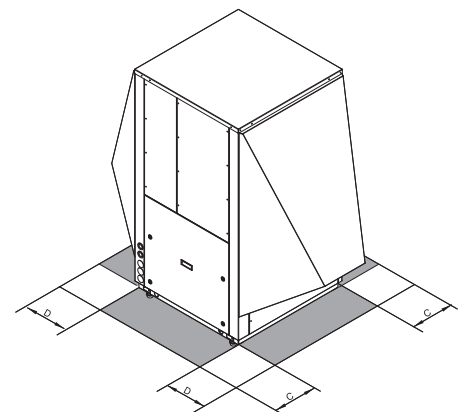
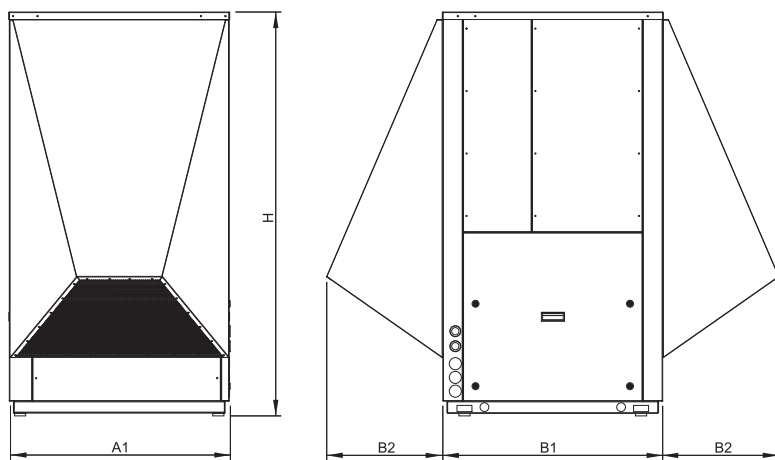

Outdoor installation

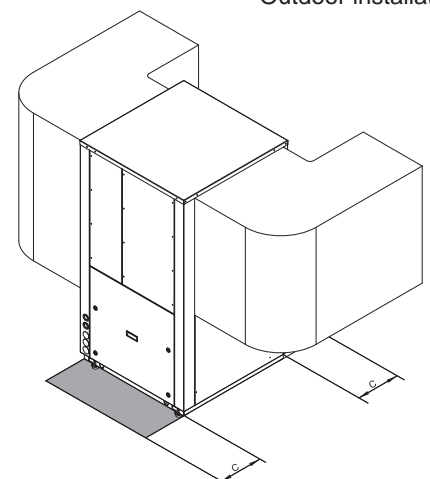

Indoor installation

	30.1 - 35.1 - 40.1	45.1 - 50.1	
A1	1180	1480	mm
B1	880	880	mm
B2	465	465	mm
H	1620	1620	mm

> HGA

AIR - WATER HEAT PUMPS FOR OUTDOOR INSTALLATION

Available range

Unit type

IP Reversible heat pump
(reversible on the refrigerant side)

Versions (heat recovery)

VB Base version
VD Desuperheater version

Acoustic setting up

AB Base setting up
AS Low noise setting up

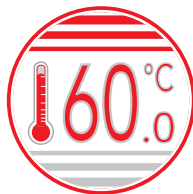

Efficiency class in heating mode - Average climate

Model	45.2	55.2	65.2	75.2	85.2	95.2
Efficiency class - medium temperature (water produce at 55°C)	A++	A++	A++	A++	A++	A++
Efficiency class - low temperature (water produce at 35°C)	A++	A++	A++	A++	A++	A++

NOTA: Declared according to **European regulation 811/2013**. The values are referred to units without options and accessories.

Unit description

This series of **air-water** heat pumps satisfies the heating, cooling and domestic hot water production requirements of autonomous or centralized residential plants of medium and large size.

All the units are suitable for outdoor installation and can be applied to **fan coil** plants, **radiant** floor plants and high efficiency **radiators** plants.

The control system allows to manage not only the refrigerant circuit but the whole plant with the possibility to choose different solutions both for the heating and cooling plant and for the domestic hot water management. The possibility of solar panels or other heating sources integration is also available.

The **heating** function optimizes the flow water temperature according both to the ambient temperature and to the outdoor temperature through climatic curves adaptable to the building features. It's possible to manage a storage tank and two independent circuits (a direct one and a mixed one).

The **domestic hot water** management allows to control the three way valve, the storage tank and the anti-legionella cycles (if necessary).

The **cooling** function can be realized through "active cooling" (refrigerant circuit inversion). When the unit is used in radiant floor plants, to avoid condensate generation, a room humidity sensor can be in-

stalled. During cooling mode operation a part of the heating power in excess can be recovered for the domestic hot water production (VD version).

The **internal programmer clock** allows to define different daily switching programs for heating, cooling and domestic hot water production.

The refrigerant circuit, contained in a box repaired from the air flow to simplify the maintenance operations, is equipped with two scroll compressors mounted on damper supports, brazed plate heat exchangers, electronic expansion valve, reverse cycle valve, axial fans, finned coil realized with copper pipes and aluminium fins. The circuit is protected by high and low pressure switches and flow switches on the plate heat exchanger.

The compressors are arranged in tandem on a single refrigerant circuit and allow the capacity modulation according to the plant requests in order to guarantee a high seasonal efficiency.

The plate heat exchanger and all the hydraulic pipes are thermally insulated in order to avoid condensate generation and reduce thermal losses.

The axial fans, equipped with electronic control of the rotational speed, guarantee high efficiencies in all the operating conditions and the possibility to reduce the noise level during the night.

All the units are provided with a phase sequence and correct sequence controller device and with an outdoor temperature

sensor in order to realize the climatic control.

All the units are accurately built and individually tested in the factory. Only electric and hydraulic connections are required for installation.

Options

Plant side flow rate management

- not present
- standard pump
- high head pump
- modulating pump
- high efficiency pump

Domestic hot water production

- not present
- 3 way valve

Soft starter

- not present
- standard

Accessories

- Rubber vibration dampers
- Spring vibration dampers
- Coil protection grilles
- Remote thermostat (wired or wireless)
- Remote control (wired or wireless)
- Wireless transmitter
- Wireless repeater
- Condensate sensor
- Room hygostat
- Room humidity sensor

CONTROL SYSTEM

The microprocessor controller is able to manage not only the unit itself but also all that components of the plant which allow to realize a complete system.

The main **functions** of the control system are :

- room temperature control according to the outdoor temperature (climatic control)
- domestic hot water production (management of 3 way valve, storage tank, anti legionella cycles...)
- management of a heating and/or cooling mixed circuit (pump and 3 way mixing valve)
- management of a heating direct circuit (only pump)
- management of a storage tank for heating and/or cooling
- management of electrical heaters for heating and domestic hot water (3 steps logic)
- solar panels integration
- room humidity control for cooling with radiant systems
- internal programmer clock (for heating, cooling and domestic hot water)
- digital input for electrical energy low tariff
- alarm memory management and diagnostic
- compressor and pump operating hour counter
- possibility to manage more units in cascade (maximum 16)

Besides the standard user interface to be placed indoor, wired or wireless remote thermostats are available which allow to control all the operating parameters of the unit and to acquire the temperature in the different zones in order to realize a more precise and comfortable control.

The unit controller is able to manage a lot of different plant solutions enabling automatically the necessary control algorithms according to the components which have been connected.

The management of such components is possible through additional expansion modules which communicate with the unit by means of an internal bus and provide all the inputs and outputs required to fulfil a complete system.

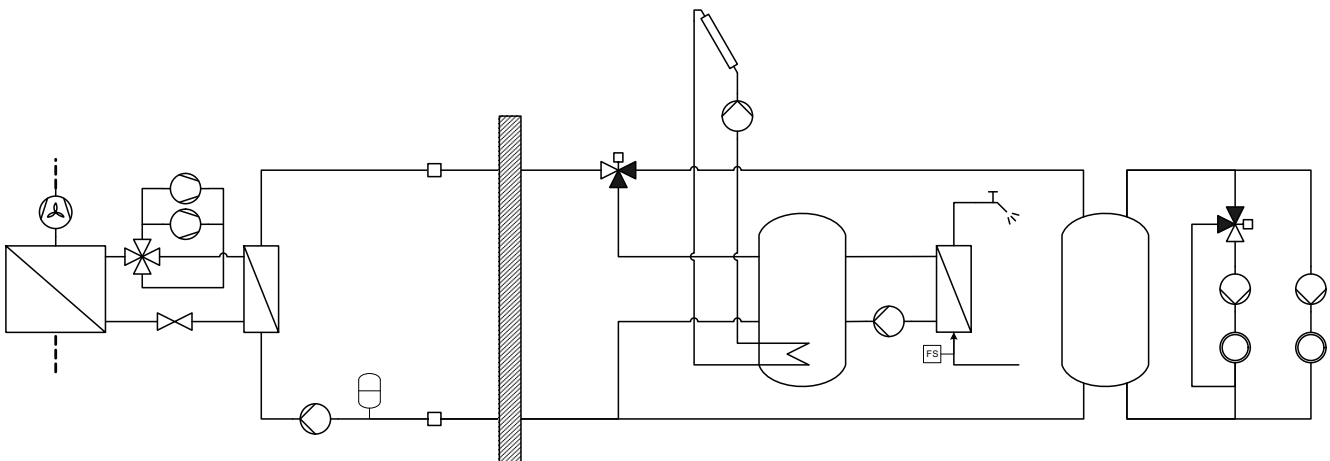
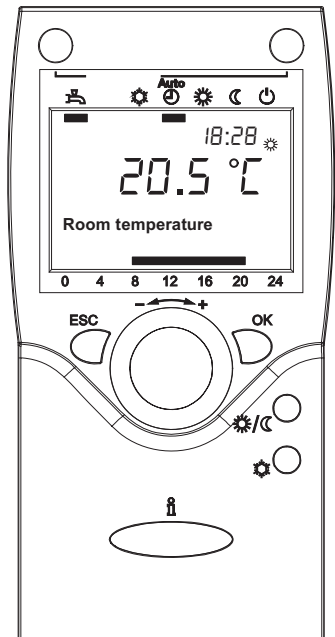

The controller is able to manage up to **two zones in heating** (one by means of a mixed circuit and the other by means of a direct circuit) and **one zone in cooling** (by means of a mixed circuit).

It's possible to realize more complex plants connecting to the heat pump controller further expansion modules in order to extend without limits the number of zones to be managed.

For each zone the following parameters can be set :

- set point
- daily or weekly operating time table
- climatic control curve
- room control sensor : it can be in common with the other zones or independent (in that case it's necessary to install an additional room thermostat)

OPERATING LIMITS	Unit type	Cooling		Heating		°C
		min	max	min	max	
Outdoor air inlet temperature	IP	5	45	-20	42	°C
Water outlet temperature	IP	6	25	30	60	°C

NOMINAL performances - Radiant plants

IP	Acoustic setting up : AB and AS	45.2	55.2	65.2	75.2	85.2	95.2	
A7W35	Heating capacity	48,2	55,4	65,2	72,9	82,2	95,8	kW
	Power input	10,3	11,9	14,0	15,7	17,7	20,7	kW
	COP	4,68	4,66	4,66	4,64	4,64	4,63	-
	Water flow rate plant side	8313	9559	11257	12573	14183	16538	l/h
	Pressure drops plant side	20	20	22	22	20	20	kPa
A2W35	Heating capacity	40,0	46,0	54,1	60,5	68,3	79,6	kW
	Power input	10,1	11,7	13,7	15,4	17,3	20,3	kW
	COP	3,96	3,93	3,95	3,93	3,95	3,92	-
	Water flow rate plant side	6910	7949	9352	10443	11793	13750	l/h
	Pressure drops plant side	14	15	16	16	14	14	kPa
A35W18	Cooling capacity	50,9	58,7	69,0	77,1	87,0	102,0	kW
	Power input	13,2	15,3	18,1	20,2	22,7	26,7	kW
	EER	3,86	3,84	3,81	3,82	3,83	3,82	-
	Water flow rate plant side	8811	10156	11949	13345	15052	17570	l/h
	Pressure drops plant side	23	23	25	25	22	22	kPa

NOMINAL performances - Standard plants

IP	Acoustic setting up : AB and AS	45.2	55.2	65.2	75.2	85.2	95.2	
A7W45	Heating capacity	46,9	54,1	63,7	71,1	80,2	93,6	kW
	Power input	12,5	14,5	17,0	19,0	21,4	25,1	kW
	COP	3,75	3,73	3,75	3,74	3,75	3,73	-
	Water flow rate plant side	8133	9367	11036	12322	13903	16215	l/h
	Pressure drops plant side	19	20	21	22	19	19	kPa
A2W45	Heating capacity	38,8	44,7	52,6	58,7	66,3	77,4	kW
	Power input	12,3	14,3	16,7	18,7	21,0	24,8	kW
	COP	3,15	3,13	3,15	3,14	3,16	3,12	-
	Water flow rate plant side	6726	7751	9124	10184	11505	13417	l/h
	Pressure drops plant side	14	14	15	15	14	14	kPa
A35W7	Cooling capacity	38,7	44,6	52,5	58,6	66,1	77,1	kW
	Power input	12,2	14,1	16,6	18,6	20,9	24,6	kW
	EER	3,17	3,16	3,16	3,15	3,16	3,13	-
	Water flow rate plant side	6659	7671	9027	10074	11361	13266	l/h
	Pressure drops plant side	14	14	15	15	13	14	kPa

NOMINAL performances - HIGH temperature plants

IP	Acoustic setting up : AB and AS	45.2	55.2	65.2	75.2	85.2	95.2	
A7W55	Heating capacity	45,1	51,9	61,2	68,4	77,1	90,0	kW
	Power input	14,4	16,7	19,7	22,1	24,8	29,0	kW
	COP	3,13	3,11	3,11	3,10	3,11	3,10	-
	Water flow rate plant side	4914	5655	6658	7442	8390	9796	l/h
	Pressure drops plant side	8	8	9	9	8	8	kPa
A2W55	Heating capacity	37,0	42,5	50,1	56,0	63,1	73,6	kW
	Power input	14,3	16,5	19,4	21,8	24,5	28,7	kW
	COP	2,59	2,58	2,58	2,57	2,58	2,56	-
	Water flow rate plant side	4032	4631	5459	6102	6876	8020	l/h
	Pressure drops plant side	5	5	6	6	5	5	kPa

Data declared according to **EN 14511**. The values are referred to units without options and accessories.

A7W65 = source : air in 7°C d.b. 6°C w.b. / plant : water in 55°C out 65°C
 A7W55 = source : air in 7°C d.b. 6°C w.b. / plant : water in 47°C out 55°C
 A7W45 = source : air in 7°C d.b. 6°C w.b. / plant : water in 40°C out 45°C
 A7W35 = source : air in 7°C d.b. 6°C w.b. / plant : water in 30°C out 35°C
 A35W7 = source : air in 35°C d.b. / plant : water in 12°C out 7°C
 A35W18 = source : air in 35°C d.b. / plant : water in 23°C out 18°C

A2W65 = source : air in 2°C d.b. 1°C w.b. / plant : water in 55°C out 65°C
 A2W55 = source : air in 2°C d.b. 1°C w.b. / plant : water in 47°C out 55°C
 A2W45 = source : air in 2°C d.b. 1°C w.b. / plant : water in 40°C out 45°C
 A2W35 = source : air in 2°C d.b. 1°C w.b. / plant : water in 30°C out 35°C

TECHNICAL DATA	45.2	55.2	65.2	75.2	85.2	95.2	
Power supply	400 - 3 - 50						V-ph-Hz
Compressor type	scroll						-
N° compressors / N° refrigerant circuits	2 / 1						n°
Plant side heat exchanger type	stainless steel brazed plates						-
Source side heat exchanger type	finned coil						-
Fans type	axial						-
N° fans	2		3		4		n°
Hydraulic fittings	2" M						-
Hydraulic fittings heat recovery (VD)	1" 1/4 M						-
Weight *	635	670	785	795	905	920	kg
Maximum power input *	21,6	24,2	27,4	29,8	35,6	40,8	kW

* base unit without options and accessories

ACOUSTIC PERFORMANCES

Base acoustic setting up (AB)	45.2	55.2	65.2	75.2	85.2	95.2	
Sound power level	79	79	80	80	81	81	dB(A)
Sound pressure level at 1 metre	61	61	62	62	62	62	dB(A)
Sound pressure level at 5 metres	52	52	53	53	54	54	dB(A)
Sound pressure level at 10 metres	47	47	48	48	49	49	dB(A)
Low noise acoustic setting up (AS)	45.2	55.2	65.2	75.2	85.2	95.2	
Sound power level	76	76	77	77	78	78	dB(A)
Sound pressure level at 1 metre	58	58	59	59	59	59	dB(A)
Sound pressure level at 5 metres	49	49	50	50	51	51	dB(A)
Sound pressure level at 10 metres	44	44	45	45	46	46	dB(A)

The acoustic performances are referred to units operating in cooling mode at nominal conditions A7W35.

Unit placed in free field on reflecting surface (directional factor equal to 2).

The sound power level is measured according to ISO 3744 standard.

The sound pressure level is calculated according to ISO 3744 and is referred to a distance of 1/5/10 metres from the external surface of the unit.

DIMENSIONS AND MINIMUM OPERATING AREA

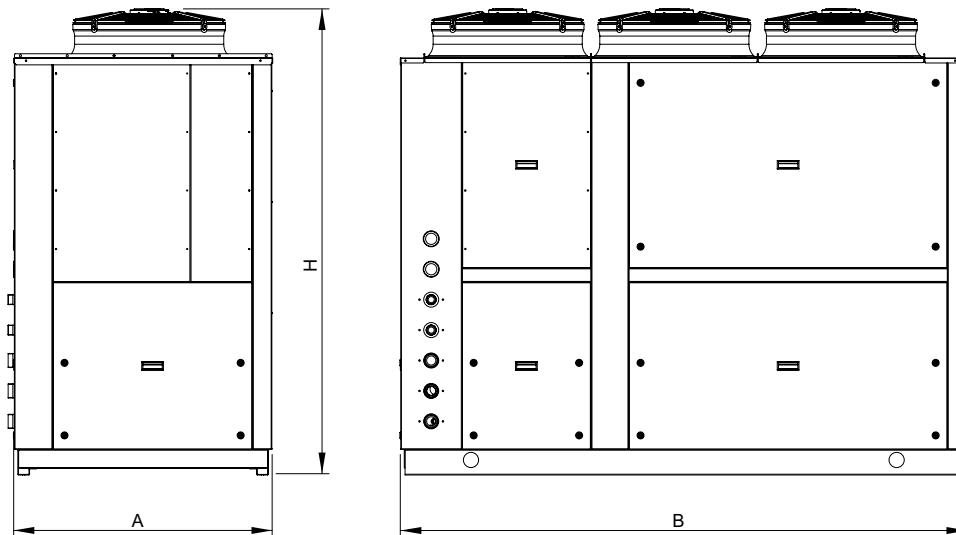

Respect the free area around the unit as shown in figure in order to guarantee a good accessibility and facilitate maintenance and control operations.

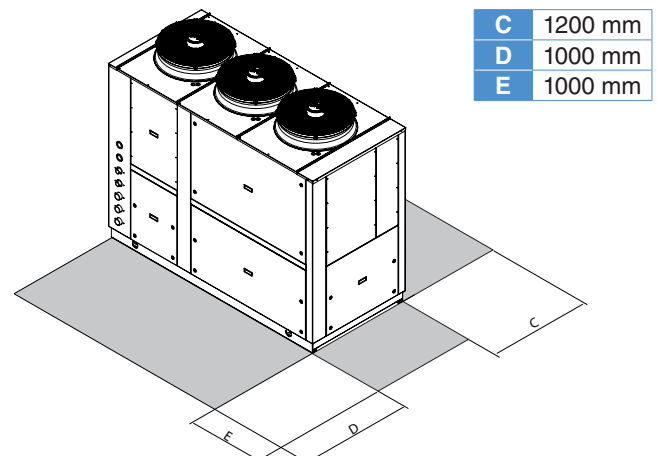

C	1200 mm
D	1000 mm
E	1000 mm

	45.2 - 55.2	65.2 - 75.2	85.2 - 95.2	
A	1130	1130	1130	mm
B	1710	2430	3130	mm
H	1980	1980	1980	mm

> HGA HT

AIR - WATER
HEAT PUMPS
FOR OUTDOOR INSTALLATION

Available range

Unit type

IP Reversible heat pump
(reversible on the refrigerant side)

Versions (heat recovery)

VB Base version
VD Desuperheater version

Acoustic setting up

AB Base setting up
AS Low noise setting up

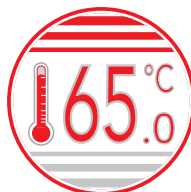

Efficiency class in heating mode - Average climate

Model	60.2	70.2	80.2	90.2	100.2
Efficiency class - medium temperature (water produce at 55°C)	A++	A++	A++	A++	A++
Efficiency class - low temperature (water produce at 35°C)	A++	A++	A++	A++	A++

NOTA: Declared according to **European regulation 811/2013**. The values are referred to units without options and accessories.

Unit description

This series of **air-water** heat pumps satisfies the heating, cooling and domestic hot water production requirements of autonomous or centralized residential plants of medium and large size.

All the units are suitable for outdoor installation. The possibility to produce water at high temperatures makes these units particularly suitable to be applied to **radiators** plants as well as to **fan coil** plants and **radiant** floor plants.

The control system allows to manage not only the refrigerant circuit but the whole plant with the possibility to choose different solutions both for the heating and cooling plant and for the domestic hot water management. The possibility of solar panels or other heating sources integration is also available.

The **heating** function optimizes the flow water temperature according both to the ambient temperature and to the outdoor temperature through climatic curves adaptable to the building features. It's possible to manage a storage tank and two independent circuits (a direct one and a mixed one).

The **domestic hot water** management allows to control the three way valve, the storage tank and the anti-legionella cycles (if necessary).

The **cooling** function can be realized through "active cooling" (refrigerant circuit inversion). When the unit is used in radiant floor plants, to avoid condensate generation, a room humidity sensor can be in-

stalled. During cooling mode operation a part of the heating power in excess can be recovered for the domestic hot water production (VD version).

The **internal programmer clock** allows to define different daily switching programs for heating, cooling and domestic hot water production.

The refrigerant circuit, contained in a box repaired from the air flow to simplify the maintenance operations, is equipped with two scroll compressors mounted on damper supports, brazed plate heat exchangers, electronic expansion valve, reverse cycle valve, axial fans, finned coil realized with copper pipes and aluminium fins. The circuit is protected by high and low pressure switches and flow switches on the plate heat exchanger.

The compressors are arranged in tandem on a single refrigerant circuit and allow the capacity modulation according to the plant requests in order to guarantee a high seasonal efficiency.

Both the compressors are equipped with vapour and liquid injection and are placed on an economized refrigerant circuit with plate heat exchanger and electronic expansion valve dedicated to the injection.

The plate heat exchanger and all the hydraulic pipes are thermally insulated in order to avoid condensate generation and reduce thermal losses.

The axial fans, equipped with electronic control of the rotational speed, guarantee high efficiencies in all the operating conditions and the possibility to reduce the noise level during the night.

All the units are provided with a phase sequence and correct sequence controller device and with an outdoor temperature sensor in order to realize the climatic control.

All the units are accurately built and individually tested in the factory. Only electric and hydraulic connections are required for installation.

Options

Plant side flow rate management

- not present
- standard pump
- high head pump
- modulating pump
- high efficiency pump

Domestic hot water production

- not present
- 3 way valve

Soft starter

- not present
- standard

Accessories

- Rubber vibration dampers
- Spring vibration dampers
- Coil protection grilles
- Remote thermostat (wired or wireless)
- Remote control (wired or wireless)
- Wireless transmitter
- Wireless repeater
- Condensate sensor
- Room hygostat
- Room humidity sensor

CONTROL SYSTEM

The microprocessor controller is able to manage not only the unit itself but also all that components of the plant which allow to realize a complete system.

The main **functions** of the control system are :

- room temperature control according to the outdoor temperature (climatic control)
- domestic hot water production (management of 3 way valve, storage tank, anti legionella cycles...)
- management of a heating and/or cooling mixed circuit (pump and 3 way mixing valve)
- management of a heating direct circuit (only pump)
- management of a storage tank for heating and/or cooling
- management of electrical heaters for heating and domestic hot water (3 steps logic)
- solar panels integration
- room humidity control for cooling with radiant systems
- internal programmer clock (for heating, cooling and domestic hot water)
- digital input for electrical energy low tariff
- alarm memory management and diagnostic
- compressor and pump operating hour counter
- possibility to manage more units in cascade (maximum 16)

Besides the standard user interface to be placed indoor, wired or wireless remote thermostats are available which allow to control all the operating parameters of the unit and to acquire the temperature in the different zones in order to realize a more precise and comfortable control.

The unit controller is able to manage a lot of different plant solutions enabling automatically the necessary control algorithms according to the components which have been connected.

The management of such components is possible through additional expansion modules which communicate with the unit by means of an internal bus and provide all the inputs and outputs required to fulfil a complete system.

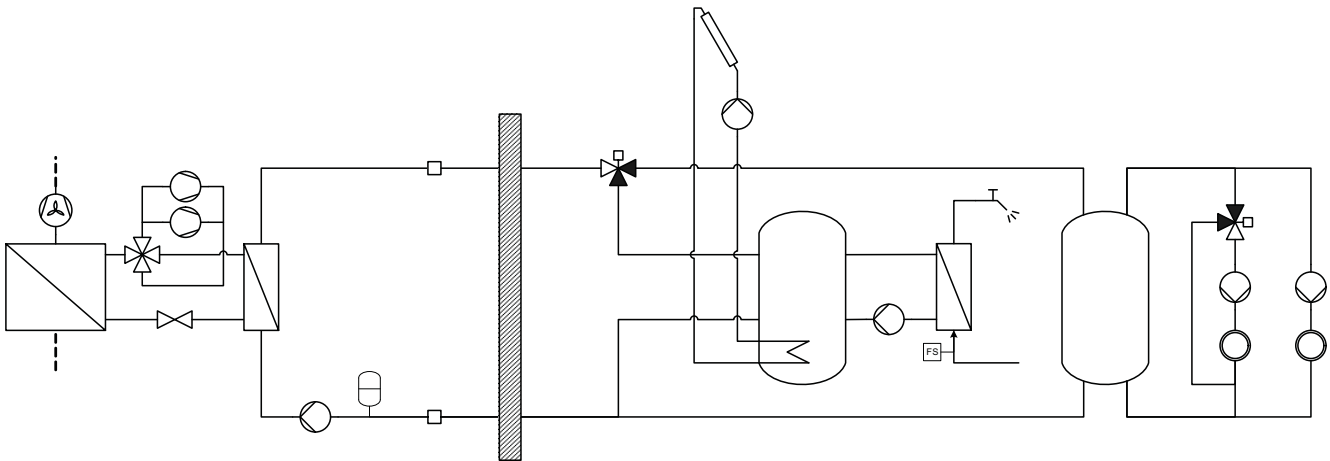
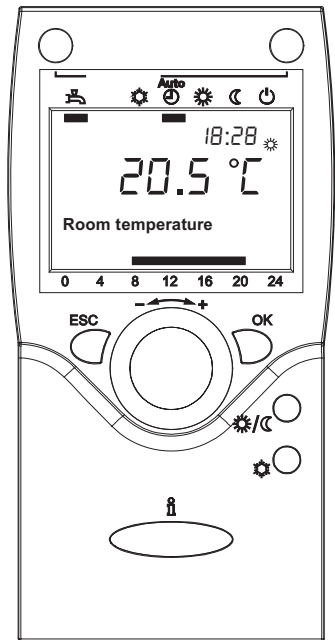

The controller is able to manage up to **two zones in heating** (one by means of a mixed circuit and the other by means of a direct circuit) and **one zone in cooling** (by means of a mixed circuit).

It's possible to realize more complex plants connecting to the heat pump controller further expansion modules in order to extend without limits the number of zones to be managed.

For each zone the following parameters can be set :

- set point
- daily or weekly operating time table
- climatic control curve
- room control sensor : it can be in common with the other zones or independent (in that case it's necessary to install an additional room thermostat)

OPERATING LIMITS	Unit type	Cooling		Heating		°C
		min	max	min	max	
Outdoor air inlet temperature	IP	5	50	-22	42	°C
Water outlet temperature	IP	6	25	30	65 *	°C

* The maximum water outlet temperature can be increased up to 70°C keeping a ΔT between inlet and outlet equal to 10°C.

NOMINAL performances - Radiant plants

IP	Acoustic setting up : AB and AS	60.2	70.2	80.2	90.2	100.2	
A7W35	Heating capacity	57,5	67,8	75,7	85,4	99,5	kW
	Power input	12,2	14,4	16,1	18,1	21,1	kW
	COP	4,71	4,71	4,70	4,72	4,72	-
	Water flow rate plant side	9923	11689	13058	14737	17179	l/h
	Pressure drops plant side	22	24	24	22	21	kPa
A2W35	Heating capacity	48,5	57,3	63,9	72,1	84,0	kW
	Power input	12,2	14,4	16,1	18,1	21,1	kW
	COP	3,98	3,98	3,97	3,98	3,98	-
	Water flow rate plant side	8382	9888	11031	12451	14512	l/h
	Pressure drops plant side	16	18	18	16	16	kPa
A35W18	Cooling capacity	58,7	69,1	77,3	87,1	102	kW
	Power input	15,3	18,1	20,2	22,7	26,6	kW
	EER	3,84	3,82	3,83	3,84	3,83	-
	Water flow rate plant side	10156	11966	13380	15070	17587	l/h
	Pressure drops plant side	23	25	25	22	22	kPa

NOMINAL performances - Standard plants

IP	Acoustic setting up : AB and AS	60.2	70.2	80.2	90.2	100.2	
A7W45	Heating capacity	58,2	68,6	76,6	86,4	101	kW
	Power input	15,6	18,4	20,5	23,1	27,0	kW
	COP	3,73	3,73	3,74	3,74	3,74	-
	Water flow rate plant side	10080	11870	13260	14963	17449	l/h
	Pressure drops plant side	22	24	25	22	22	kPa
A2W45	Heating capacity	49,3	58,2	64,9	73,3	85,4	kW
	Power input	15,5	18,3	20,5	23,1	27,0	kW
	COP	3,18	3,18	3,17	3,17	3,16	-
	Water flow rate plant side	8551	10080	11244	12704	14807	l/h
	Pressure drops plant side	17	18	18	16	16	kPa
A35W7	Cooling capacity	44,6	52,6	58,7	66,2	77,2	kW
	Power input	14,1	16,6	18,6	20,9	24,5	kW
	EER	3,16	3,17	3,16	3,17	3,15	-
	Water flow rate plant side	7671	9044	10091	11378	13283	l/h
	Pressure drops plant side	14	15	15	14	14	kPa

NOMINAL performances - HIGH temperature and VERY HIGH temperature plants

IP	Acoustic setting up : AB and AS	60.2	70.2	80.2	90.2	100.2	
A7W65	Heating capacity	60,5	71,2	79,5	89,8	105	kW
	Power input	23,8	27,9	31,3	35,3	41,3	kW
	COP	2,54	2,55	2,54	2,54	2,54	-
	Water flow rate plant side	5293	6229	6955	7856	9160	l/h
	Pressure drops plant side	7	8	8	7	7	kPa
A2W65	Heating capacity	51,8	61,0	68,2	77,0	89,7	kW
	Power input	23,8	28,0	31,4	35,3	41,3	kW
	COP	2,18	2,18	2,17	2,18	2,17	-
	Water flow rate plant side	4532	5337	5967	6736	7847	l/h
	Pressure drops plant side	5	6	6	5	5	kPa
A7W55	Heating capacity	59,2	69,7	77,8	87,8	102	kW
	Power input	19,1	22,5	25,1	28,3	33,1	kW
	COP	3,10	3,10	3,10	3,10	3,08	-
	Water flow rate plant side	6440	7584	8466	9556	11147	l/h
	Pressure drops plant side	10	11	11	10	10	kPa
A2W55	Heating capacity	50,3	59,3	66,3	74,9	87,3	kW
	Power input	19,1	22,4	25,2	28,4	33,2	kW
	COP	2,63	2,65	2,63	2,64	2,63	-
	Water flow rate plant side	5481	6462	7213	8150	9502	l/h
	Pressure drops plant side	7	8	8	7	7	kPa

Data declared according to **EN 14511**. The values are referred to units without options and accessories.

A7W65 = source : air in 7°C d.b. 6°C w.b. / plant : water in 55°C out 65°C
 A7W55 = source : air in 7°C d.b. 6°C w.b. / plant : water in 47°C out 55°C
 A7W45 = source : air in 7°C d.b. 6°C w.b. / plant : water in 40°C out 45°C
 A7W35 = source : air in 7°C d.b. 6°C w.b. / plant : water in 30°C out 35°C
 A35W7 = source : air in 35°C d.b. / plant : water in 12°C out 7°C
 A35W18 = source : air in 35°C d.b. / plant : water in 23°C out 18°C

A2W65 = source : air in 2°C d.b. 1°C w.b. / plant : water in 55°C out 65°C
 A2W55 = source : air in 2°C d.b. 1°C w.b. / plant : water in 47°C out 55°C
 A2W45 = source : air in 2°C d.b. 1°C w.b. / plant : water in 40°C out 45°C
 A2W35 = source : air in 2°C d.b. 1°C w.b. / plant : water in 30°C out 35°C

TECHNICAL DATA	60.2	70.2	80.2	90.2	100.2	
Power supply	400 - 3 - 50					V-ph-Hz
Compressor type	scroll with vapour injection (EVI)					-
N° compressors / N° refrigerant circuits	2 / 1					n°
Plant side heat exchanger type	stainless steel brazed plates					-
Source side heat exchanger type	finned coil					-
Fans type	axial					-
N° fans	2	3		4		n°
Hydraulic fittings	2" M					-
Hydraulic fittings heat recovery (VD)	1" 1/4 M					-
Weight *	690	805	815	926	941	kg
Maximum power input *	27,8	31,6	34,8	40,0	45,8	kW

* base unit without options and accessories

ACOUSTIC PERFORMANCES

Base acoustic setting up (AB)	60.2	70.2	80.2	90.2	100.2	
Sound power level	79	80	80	81	81	dB(A)
Sound pressure level at 1 metre	61	62	62	62	62	dB(A)
Sound pressure level at 5 metres	52	53	53	54	54	dB(A)
Sound pressure level at 10 metres	47	48	48	49	49	dB(A)
Low noise acoustic setting up (AS)	60.2	70.2	80.2	90.2	100.2	
Sound power level	76	77	77	78	78	dB(A)
Sound pressure level at 1 metre	58	59	59	59	59	dB(A)
Sound pressure level at 5 metres	49	50	50	51	51	dB(A)
Sound pressure level at 10 metres	44	45	45	46	46	dB(A)

The acoustic performances are referred to units operating in cooling mode at nominal conditions A7W35.

Unit placed in free field on reflecting surface (directional factor equal to 2).

The sound power level is measured according to ISO 3744 standard.

The sound pressure level is calculated according to ISO 3744 and is referred to a distance of 1/5/10 metres from the external surface of the unit.

DIMENSIONS AND MINIMUM OPERATING AREA

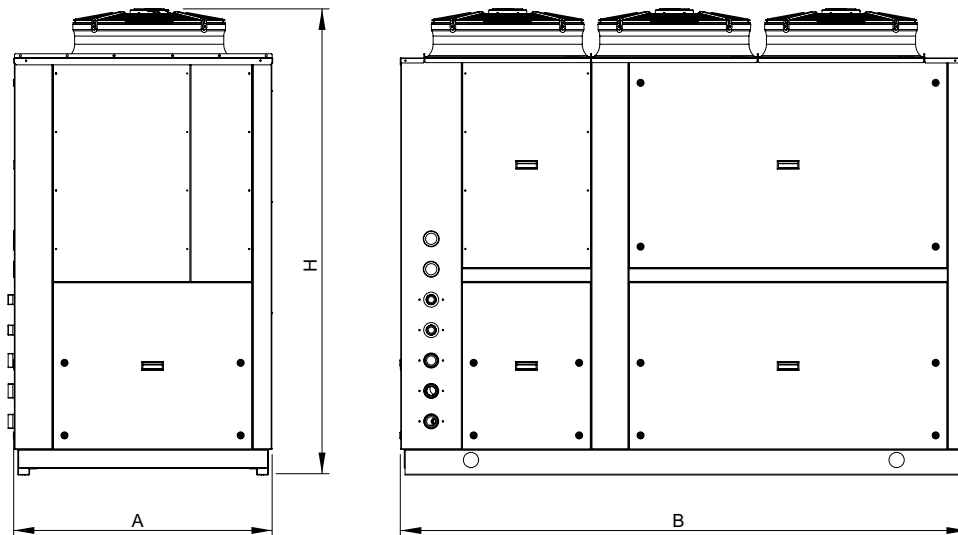

Respect the free area around the unit as shown in figure in order to guarantee a good accessibility and facilitate maintenance and control operations.

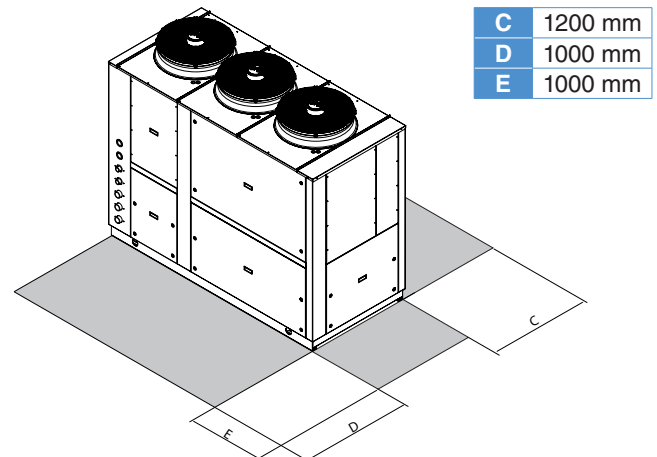

	60.2	70.2 - 80.2	90.2 - 100.2	
A	1130	1130	1130	mm
B	1710	2430	3130	mm
H	1980	1980	1980	mm

> HGP

AIR - WATER HEAT PUMPS FOR INDOOR INSTALLATION

Available range

Unit type

IP Reversible heat pump
(reversible on the refrigerant side)

Versions (heat recovery)

VB Base version
VD Desuperheater version

Acoustic setting up

AB Base setting up
AS Low noise setting up

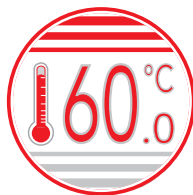

Efficiency class in heating mode - Average climate

Model	45.2	55.2	65.2	75.2	85.2	95.2
Efficiency class - medium temperature (water produce at 55°C)	A++	A++	A++	A++	A++	A++
Efficiency class - low temperature (water produce at 35°C)	A++	A++	A++	A++	A++	A++

NOTA: Declared according to **European regulation 811/2013**. The values are referred to units without options and accessories.

Unit description

This series of **air-water** heat pumps satisfies the heating, cooling and domestic hot water production requirements of autonomous or centralized residential plants of medium and large size.

All the units are suitable for indoor installation and can be applied to **fan coil** plants, **radiant** floor plants and high efficiency **radiators** plants.

The control system allows to manage not only the refrigerant circuit but the whole plant with the possibility to choose different solutions both for the heating and cooling plant and for the domestic hot water management. The possibility of solar panels or other heating sources integration is also available.

The **heating** function optimizes the flow water temperature according both to the ambient temperature and to the outdoor temperature through climatic curves adaptable to the building features. It's possible to manage a storage tank and two independent circuits (a direct one and a mixed one).

The **domestic hot water** management allows to control the three way valve, the storage tank and the anti-legionella cycles (if necessary).

The **cooling** function can be realized through "active cooling" (refrigerant circuit inversion). When the unit is used in radiant floor plants, to avoid condensate generation, a room humidity sensor can be in-

stalled. During cooling mode operation a part of the heating power in excess can be recovered for the domestic hot water production (VD version).

The **internal programmer clock** allows to define different daily switching programs for heating, cooling and domestic hot water production.

The refrigerant circuit, contained in a box repaired from the air flow to simplify the maintenance operations, is equipped with two scroll compressors mounted on damper supports, brazed plate heat exchangers, electronic expansion valve, reverse cycle valve, centrifugal fans (plug fans), finned coil realized with copper pipes and aluminium fins. The circuit is protected by high and low pressure switches and flow switches on the plate heat exchanger.

The compressors are arranged in tandem on a single refrigerant circuit and allow the capacity modulation according to the plant requests in order to guarantee a high seasonal efficiency.

The plate heat exchanger and all the hydraulic pipes are thermally insulated in order to avoid condensate generation and reduce thermal losses.

The plug fans with electronic control of the rotational speed guarantee high efficiencies and low noise in all the operating conditions and allow to install the unit indoor (with ducted air inlet and outlet). It is moreover possible to reduce the noise level during the night.

All the units are provided with a phase se-

quence and correct sequence controller device and with an outdoor temperature sensor in order to realize the climatic control.

All the units are accurately built and individually tested in the factory. Only electric and hydraulic connections are required for installation.

Options

Plant side flow rate management

- not present
- standard pump
- high head pump
- modulating pump
- high efficiency pump

Domestic hot water production

- not present
- 3 way valve

Soft starter

- not present
- standard

Accessories

- Rubber vibration dampers
- Spring vibration dampers
- Coil protection grilles
- Remote thermostat (wired or wireless)
- Remote control (wired or wireless)
- Wireless transmitter
- Wireless repeater
- Condensate sensor
- Room hygostat
- Room humidity sensor

CONTROL SYSTEM

The microprocessor controller is able to manage not only the unit itself but also all that components of the plant which allow to realize a complete system.

The main **functions** of the control system are :

- room temperature control according to the outdoor temperature (climatic control)
- domestic hot water production (management of 3 way valve, storage tank, anti legionella cycles...)
- management of a heating and/or cooling mixed circuit (pump and 3 way mixing valve)
- management of a heating direct circuit (only pump)
- management of a storage tank for heating and/or cooling
- management of electrical heaters for heating and domestic hot water (3 steps logic)
- solar panels integration
- room humidity control for cooling with radiant systems
- internal programmer clock (for heating, cooling and domestic hot water)
- digital input for electrical energy low tariff
- alarm memory management and diagnostic
- compressor and pump operating hour counter
- possibility to manage more units in cascade (maximum 16)

Besides the standard user interface to be placed indoor, wired or wireless remote thermostats are available which allow to control all the operating parameters of the unit and to acquire the temperature in the different zones in order to realize a more precise and comfortable control.

The unit controller is able to manage a lot of different plant solutions enabling automatically the necessary control algorithms according to the components which have been connected.

The management of such components is possible through additional expansion modules which communicate with the unit by means of an internal bus and provide all the inputs and outputs required to fulfil a complete system.

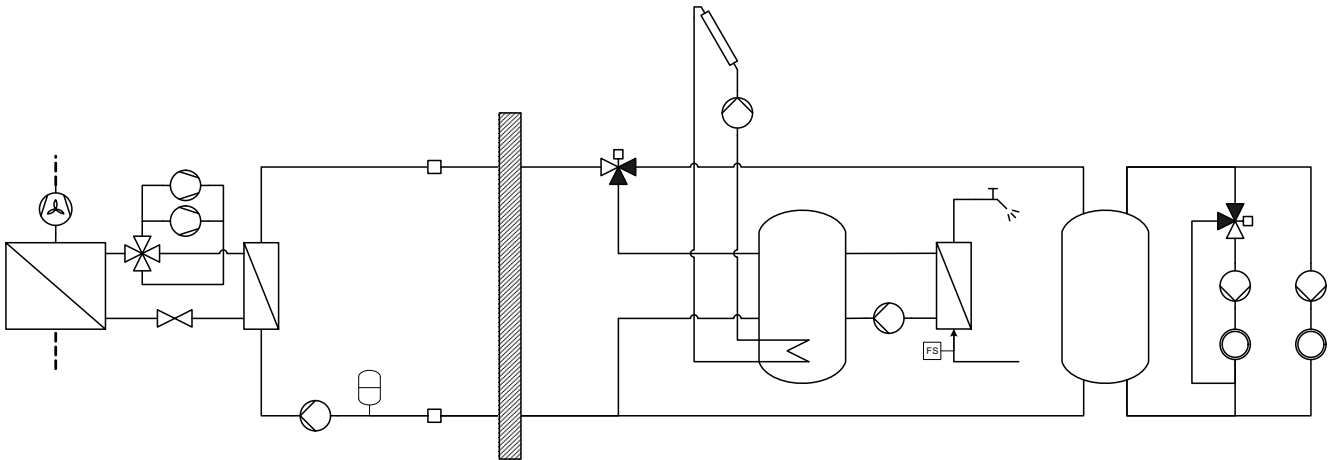
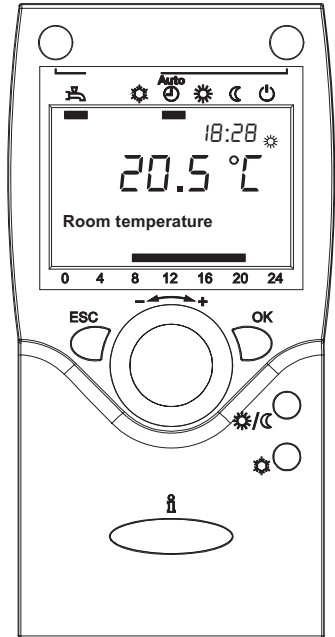

The controller is able to manage up to **two zones in heating** (one by means of a mixed circuit and the other by means of a direct circuit) and **one zone in cooling** (by means of a mixed circuit).

It's possible to realize more complex plants connecting to the heat pump controller further expansion modules in order to extend without limits the number of zones to be managed.

For each zone the following parameters can be set :

- set point
- daily or weekly operating time table
- climatic control curve
- room control sensor : it can be in common with the other zones or independent (in that case it's necessary to install an additional room thermostat)

AERAUIC performances	45.2	55.2	65.2	75.2	85.2	95.2	
Nominal air flow rate	17600	17600	26400	26400	35200	35200	m ³ /h
Nominal available static head	150	150	150	150	150	150	Pa

OPERATING LIMITS	Unit type	Cooling		Heating		
		min	max	min	max	
Outdoor air inlet temperature	IP	5	45	-20	42	°C
Water outlet temperature	IP	6	25	30	60	°C

NOMINAL performances - Radiant plants

IP	Acoustic setting up : AB and AS	45.2	55.2	65.2	75.2	85.2	95.2	
A7W35	Heating capacity	48,2	55,4	65,2	72,9	82,2	95,8	kW
	Power input	10,3	11,9	14,0	15,7	17,7	20,7	kW
	COP	4,68	4,66	4,66	4,64	4,64	4,63	-
	Water flow rate plant side	8313	9559	11257	12573	14183	16538	l/h
	Pressure drops plant side	20	20	22	22	20	20	kPa
A2W35	Heating capacity	40,0	46,0	54,1	60,5	68,3	79,6	kW
	Power input	10,1	11,7	13,7	15,4	17,3	20,3	kW
	COP	3,96	3,93	3,95	3,93	3,95	3,92	-
	Water flow rate plant side	6910	7949	9352	10443	11793	13750	l/h
	Pressure drops plant side	14	15	16	16	14	14	kPa
A35W18	Cooling capacity	50,9	58,7	69,0	77,1	87,0	102,0	kW
	Power input	13,2	15,3	18,1	20,2	22,7	26,7	kW
	EER	3,86	3,84	3,81	3,82	3,83	3,82	-
	Water flow rate plant side	8811	10156	11949	13345	15052	17570	l/h
	Pressure drops plant side	23	23	25	25	22	22	kPa

NOMINAL performances - Standard plants

IP	Acoustic setting up : AB and AS	45.2	55.2	65.2	75.2	85.2	95.2	
A7W45	Heating capacity	46,9	54,1	63,7	71,1	80,2	93,6	kW
	Power input	12,5	14,5	17,0	19,0	21,4	25,1	kW
	COP	3,75	3,73	3,75	3,74	3,75	3,73	-
	Water flow rate plant side	8133	9367	11036	12322	13903	16215	l/h
	Pressure drops plant side	19	20	21	22	19	19	kPa
A2W45	Heating capacity	38,8	44,7	52,6	58,7	66,3	77,4	kW
	Power input	12,3	14,3	16,7	18,7	21,0	24,8	kW
	COP	3,15	3,13	3,15	3,14	3,16	3,12	-
	Water flow rate plant side	6726	7751	9124	10184	11505	13417	l/h
	Pressure drops plant side	14	14	15	15	14	14	kPa
A35W7	Cooling capacity	38,7	44,6	52,5	58,6	66,1	77,1	kW
	Power input	12,2	14,1	16,6	18,6	20,9	24,6	kW
	EER	3,17	3,16	3,16	3,15	3,16	3,13	-
	Water flow rate plant side	6659	7671	9027	10074	11361	13266	l/h
	Pressure drops plant side	14	14	15	15	13	14	kPa

NOMINAL performances - HIGH temperature plants

IP	Acoustic setting up : AB and AS	45.2	55.2	65.2	75.2	85.2	95.2	
A7W55	Heating capacity	45,1	51,9	61,2	68,4	77,1	90,0	kW
	Power input	14,4	16,7	19,7	22,1	24,8	29,0	kW
	COP	3,13	3,11	3,11	3,10	3,11	3,10	-
	Water flow rate plant side	4914	5655	6658	7442	8390	9796	l/h
	Pressure drops plant side	8	8	9	9	8	8	kPa
A2W55	Heating capacity	37,0	42,5	50,1	56,0	63,1	73,6	kW
	Power input	14,3	16,5	19,4	21,8	24,5	28,7	kW
	COP	2,59	2,58	2,58	2,57	2,58	2,56	-
	Water flow rate plant side	4032	4631	5459	6102	6876	8020	l/h
	Pressure drops plant side	5	5	6	6	5	5	kPa

Data declared according to **EN 14511**. The values are referred to units without options and accessories.

A7W65 = source : air in 7°C d.b. 6°C w.b. / plant : water in 55°C out 65°C
 A7W55 = source : air in 7°C d.b. 6°C w.b. / plant : water in 47°C out 55°C
 A7W45 = source : air in 7°C d.b. 6°C w.b. / plant : water in 40°C out 45°C
 A7W35 = source : air in 7°C d.b. 6°C w.b. / plant : water in 30°C out 35°C
 A35W7 = source : air in 35°C d.b. / plant : water in 12°C out 7°C
 A35W18 = source : air in 35°C d.b. / plant : water in 23°C out 18°C

A2W65 = source : air in 2°C d.b. 1°C w.b. / plant : water in 55°C out 65°C
 A2W55 = source : air in 2°C d.b. 1°C w.b. / plant : water in 47°C out 55°C
 A2W45 = source : air in 2°C d.b. 1°C w.b. / plant : water in 40°C out 45°C
 A2W35 = source : air in 2°C d.b. 1°C w.b. / plant : water in 30°C out 35°C

TECHNICAL DATA	45.2	55.2	65.2	75.2	85.2	95.2	
Power supply	400 - 3 - 50						V-ph-Hz
Compressor type	scroll						-
N° compressors / N° refrigerant circuits	2 / 1						n°
Plant side heat exchanger type	stainless steel brazed plates						-
Source side heat exchanger type	finned coil						-
Fans type	plug fan						-
N° fans	2		3		4		n°
Hydraulic fittings	2" M						-
Hydraulic fittings heat recovery (VD)	1" 1/4 M						-
Weight *	715	750	905	915	1065	1080	kg
Maximum power input *	24,4	27,0	31,6	34,0	41,2	46,4	kW

* base unit without options and accessories

ACOUSTIC PERFORMANCES

Base acoustic setting up (AB)	45.2	55.2	65.2	75.2	85.2	95.2	
Sound power level	80	80	81	81	82	82	dB(A)
Sound pressure level at 1 metre	63	63	64	64	64	64	dB(A)
Sound pressure level at 5 metres	54	54	54	55	55	56	dB(A)
Sound pressure level at 10 metres	48	49	49	50	50	51	dB(A)
Low noise acoustic setting up (AS)	45.2	55.2	65.2	75.2	85.2	95.2	
Sound power level	77	77	78	78	79	79	dB(A)
Sound pressure level at 1 metre	60	60	61	61	61	61	dB(A)
Sound pressure level at 5 metres	51	51	51	52	52	53	dB(A)
Sound pressure level at 10 metres	45	46	46	47	47	48	dB(A)

The acoustic performances are referred to units operating in cooling mode at nominal conditions A7W35.

Unit placed in free field on reflecting surface (directional factor equal to 2).

The sound power level is measured according to ISO 3744 standard.

The sound pressure level is calculated according to ISO 3744 and is referred to a distance of 1/5/10 metres from the external surface of the unit.

DIMENSIONS AND MINIMUM OPERATING AREA

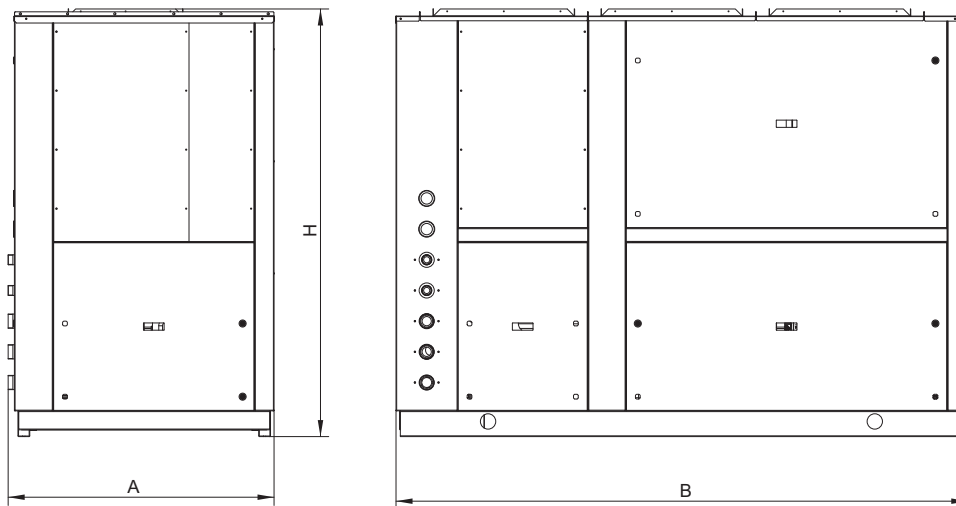

Respect the free area around the unit as shown in figure in order to guarantee a good accessibility and facilitate maintenance and control operations.

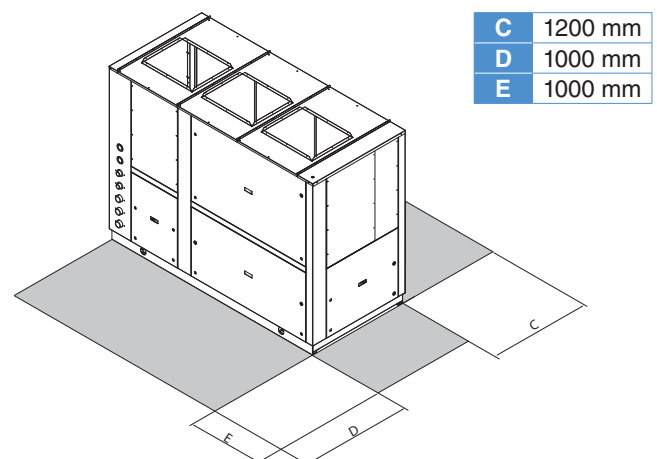

	45.2 - 55.2	65.2 - 75.2	85.2 - 95.2	
A	1130	1130	1130	mm
B	1710	2430	3130	mm
H	1810	1810	1810	mm

> HGP HT

AIR - WATER
HEAT PUMPS
FOR INDOOR INSTALLATION

Available range

Unit type

IP Reversible heat pump
(reversible on the refrigerant side)

Versions (heat recovery)

VB Base version
VD Desuperheater version

Acoustic setting up

AB Base setting up
AS Low noise setting up

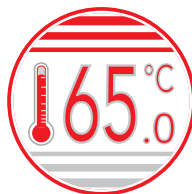

Efficiency class in heating mode - Average climate

Model	60.2	70.2	80.2	90.2	100.2
Efficiency class - medium temperature (water produce at 55°C)	A++	A++	A++	A++	A++
Efficiency class - low temperature (water produce at 35°C)	A++	A++	A++	A++	A++

NOTA: Declared according to **European regulation 811/2013**. The values are referred to units without options and accessories.

Unit description

This series of **air-water** heat pumps satisfies the heating, cooling and domestic hot water production requirements of autonomous or centralized residential plants of medium and large size.

All the units are suitable for indoor installation. The possibility to produce water at high temperatures makes these units particularly suitable to be applied to **radiators** plants as well as to **fan coil** plants and **radiant** floor plants.

The control system allows to manage not only the refrigerant circuit but the whole plant with the possibility to choose different solutions both for the heating and cooling plant and for the domestic hot water management. The possibility of solar panels or other heating sources integration is also available.

The **heating** function optimizes the flow water temperature according both to the ambient temperature and to the outdoor temperature through climatic curves adaptable to the building features. It's possible to manage a storage tank and two independent circuits (a direct one and a mixed one).

The **domestic hot water** management allows to control the three way valve, the storage tank and the anti-legionella cycles (if necessary).

The **cooling** function can be realized through "active cooling" (refrigerant circuit inversion). When the unit is used in radiant floor plants, to avoid condensate generation, a room humidity sensor can be installed. During cooling mode operation a

part of the heating power in excess can be recovered for the domestic hot water production (VD version).

The **internal programmer clock** allows to define different daily switching programs for heating, cooling and domestic hot water production.

The refrigerant circuit, contained in a box repaired from the air flow to simplify the maintenance operations, is equipped with two scroll compressors mounted on damper supports, brazed plate heat exchangers, electronic expansion valve, reverse cycle valve, centrifugal fans (plug fans), finned coil realized with copper pipes and aluminium fins. The circuit is protected by high and low pressure switches and flow switches on the plate heat exchanger.

The compressors are arranged in tandem on a single refrigerant circuit and allow the capacity modulation according to the plant requests in order to guarantee a high seasonal efficiency.

Both the compressors are equipped with vapour and liquid injection and are placed on an economized refrigerant circuit with plate heat exchanger and electronic expansion valve dedicated to the injection.

The plate heat exchanger and all the hydraulic pipes are thermally insulated in order to avoid condensate generation and reduce thermal losses.

The plug fans with electronic control of the rotational speed guarantee high efficiencies and low noise in all the operating conditions and allow to install the unit indoor (with ducted air inlet and outlet). It is moreover possible to reduce the noise level during the night.

All the units are provided with a phase sequence and correct sequence controller device and with an outdoor temperature sensor in order to realize the climatic control.

All the units are accurately built and individually tested in the factory. Only electric and hydraulic connections are required for installation.

Options

Plant side flow rate management

- not present
- standard pump
- high head pump
- modulating pump
- high efficiency pump

Domestic hot water production

- not present
- 3 way valve

Soft starter

- not present
- standard

Accessories

- Rubber vibration dampers
- Spring vibration dampers
- Coil protection grilles
- Remote thermostat (wired or wireless)
- Remote control (wired or wireless)
- Wireless transmitter
- Wireless repeater
- Condensate sensor
- Room hygostat
- Room humidity sensor

CONTROL SYSTEM

The microprocessor controller is able to manage not only the unit itself but also all that components of the plant which allow to realize a complete system.

The main **functions** of the control system are :

- room temperature control according to the outdoor temperature (climatic control)
- domestic hot water production (management of 3 way valve, storage tank, anti legionella cycles...)
- management of a heating and/or cooling mixed circuit (pump and 3 way mixing valve)
- management of a heating direct circuit (only pump)
- management of a storage tank for heating and/or cooling
- management of electrical heaters for heating and domestic hot water (3 steps logic)
- solar panels integration
- room humidity control for cooling with radiant systems
- internal programmer clock (for heating, cooling and domestic hot water)
- digital input for electrical energy low tariff
- alarm memory management and diagnostic
- compressor and pump operating hour counter
- possibility to manage more units in cascade (maximum 16)

Besides the standard user interface to be placed indoor, wired or wireless remote thermostats are available which allow to control all the operating parameters of the unit and to acquire the temperature in the different zones in order to realize a more precise and comfortable control.

The unit controller is able to manage a lot of different plant solutions enabling automatically the necessary control algorithms according to the components which have been connected.

The management of such components is possible through additional expansion modules which communicate with the unit by means of an internal bus and provide all the inputs and outputs required to fulfil a complete system.

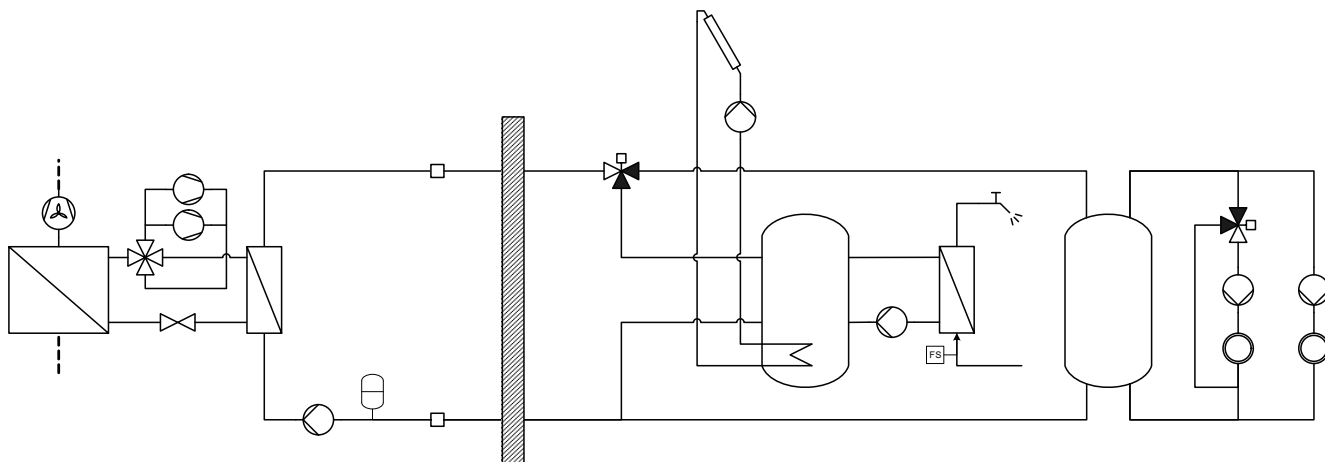
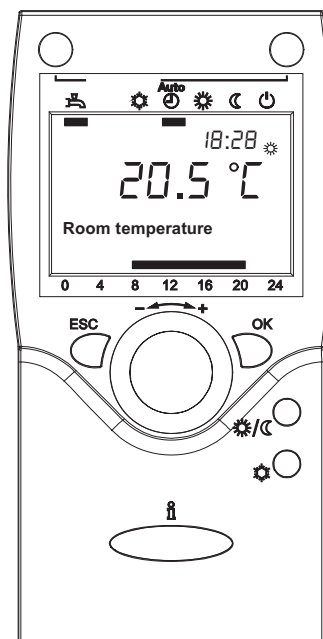

The controller is able to manage up to **two zones in heating** (one by means of a mixed circuit and the other by means of a direct circuit) and **one zone in cooling** (by means of a mixed circuit).

It's possible to realize more complex plants connecting to the heat pump controller further expansion modules in order to extend without limits the number of zones to be managed.

For each zone the following parameters can be set :

- set point
- daily or weekly operating time table
- climatic control curve
- room control sensor : it can be in common with the other zones or independent (in that case it's necessary to install an additional room thermostat)

AERAUIC performances	60.2	70.2	80.2	90.2	100.2	
Nominal air flow rate	17600	26400	26400	35200	35200	m ³ /h
Nominal available static head	150	150	150	150	150	Pa

OPERATING LIMITS	Unit type	Cooling		Heating		
		min	max	min	max	
Outdoor air inlet temperature	IP	5	50	-22	42	°C
Water outlet temperature	IP	6	25	30	65 *	°C

* The maximum water outlet temperature can be increased up to 70°C keeping a ΔT between inlet and outlet equal to 10°C.

NOMINAL performances - Radiant plants

IP	Acoustic setting up : AB and AS	60.2	70.2	80.2	90.2	100.2	
A7W35	Heating capacity	57,5	67,8	75,7	85,4	99,5	kW
	Power input	12,2	14,4	16,1	18,1	21,1	kW
	COP	4,71	4,71	4,70	4,72	4,72	-
	Water flow rate plant side	9923	11689	13058	14737	17179	l/h
	Pressure drops plant side	22	24	24	22	21	kPa
A2W35	Heating capacity	48,5	57,3	63,9	72,1	84,0	kW
	Power input	12,2	14,4	16,1	18,1	21,1	kW
	COP	3,98	3,98	3,97	3,98	3,98	-
	Water flow rate plant side	8382	9888	11031	12451	14512	l/h
	Pressure drops plant side	16	18	18	16	16	kPa
A35W18	Cooling capacity	58,7	69,1	77,3	87,1	102	kW
	Power input	15,3	18,1	20,2	22,7	26,6	kW
	EER	3,84	3,82	3,83	3,84	3,83	-
	Water flow rate plant side	10156	11966	13380	15070	17587	l/h
	Pressure drops plant side	23	25	25	22	22	kPa

NOMINAL performances - Standard plants

IP	Acoustic setting up : AB and AS	60.2	70.2	80.2	90.2	100.2	
A7W45	Heating capacity	58,2	68,6	76,6	86,4	101	kW
	Power input	15,6	18,4	20,5	23,1	27,0	kW
	COP	3,73	3,73	3,74	3,74	3,74	-
	Water flow rate plant side	10080	11870	13260	14963	17449	l/h
	Pressure drops plant side	22	24	25	22	22	kPa
A2W45	Heating capacity	49,3	58,2	64,9	73,3	85,4	kW
	Power input	15,5	18,3	20,5	23,1	27,0	kW
	COP	3,18	3,18	3,17	3,17	3,16	-
	Water flow rate plant side	8551	10080	11244	12704	14807	l/h
	Pressure drops plant side	17	18	18	16	16	kPa
A35W7	Cooling capacity	44,6	52,6	58,7	66,2	77,2	kW
	Power input	14,1	16,6	18,6	20,9	24,5	kW
	EER	3,16	3,17	3,16	3,17	3,15	-
	Water flow rate plant side	7671	9044	10091	11378	13283	l/h
	Pressure drops plant side	14	15	15	14	14	kPa

NOMINAL performances - HIGH temperature and VERY HIGH temperature plants

IP	Acoustic setting up : AB and AS	60.2	70.2	80.2	90.2	100.2	
A7W65	Heating capacity	60,5	71,2	79,5	89,8	105	kW
	Power input	23,8	27,9	31,3	35,3	41,3	kW
	COP	2,54	2,55	2,54	2,54	2,54	-
	Water flow rate plant side	5293	6229	6955	7856	9160	l/h
	Pressure drops plant side	7	8	8	7	7	kPa
A2W65	Heating capacity	51,8	61,0	68,2	77,0	89,7	kW
	Power input	23,8	28,0	31,4	35,3	41,3	kW
	COP	2,18	2,18	2,17	2,18	2,17	-
	Water flow rate plant side	4532	5337	5967	6736	7847	l/h
	Pressure drops plant side	5	6	6	5	5	kPa
A7W55	Heating capacity	59,2	69,7	77,8	87,8	102	kW
	Power input	19,1	22,5	25,1	28,3	33,1	kW
	COP	3,10	3,10	3,10	3,10	3,08	-
	Water flow rate plant side	6440	7584	8466	9556	11147	l/h
	Pressure drops plant side	10	11	11	10	10	kPa
A2W55	Heating capacity	50,3	59,3	66,3	74,9	87,3	kW
	Power input	19,1	22,4	25,2	28,4	33,2	kW
	COP	2,63	2,65	2,63	2,64	2,63	-
	Water flow rate plant side	5481	6462	7213	8150	9502	l/h
	Pressure drops plant side	7	8	8	7	7	kPa

Data declared according to **EN 14511**. The values are referred to units without options and accessories.

A7W65 = source : air in 7°C d.b. 6°C w.b. / plant : water in 55°C out 65°C
 A7W55 = source : air in 7°C d.b. 6°C w.b. / plant : water in 47°C out 55°C
 A7W45 = source : air in 7°C d.b. 6°C w.b. / plant : water in 40°C out 45°C
 A7W35 = source : air in 7°C d.b. 6°C w.b. / plant : water in 30°C out 35°C
 A35W7 = source : air in 35°C d.b. / plant : water in 12°C out 7°C
 A35W18 = source : air in 35°C d.b. / plant : water in 23°C out 18°C

A2W65 = source : air in 2°C d.b. 1°C w.b. / plant : water in 55°C out 65°C
 A2W55 = source : air in 2°C d.b. 1°C w.b. / plant : water in 47°C out 55°C
 A2W45 = source : air in 2°C d.b. 1°C w.b. / plant : water in 40°C out 45°C
 A2W35 = source : air in 2°C d.b. 1°C w.b. / plant : water in 30°C out 35°C

TECHNICAL DATA	60.2	70.2	80.2	90.2	100.2	
Power supply	400 - 3 - 50					V-ph-Hz
Compressor type	scroll with vapour injection (EVI)					-
N° compressors / N° refrigerant circuits	2 / 1					n°
Plant side heat exchanger type	stainless steel brazed plates					-
Source side heat exchanger type	finned coil					-
Fans type	plug fan					-
N° fans	2	3		4		n°
Hydraulic fittings	2" M					-
Hydraulic fittings heat recovery (VD)	1" 1/4 M					-
Weight *	770	925	935	1086	1101	kg
Maximum power input *	30,6	35,8	39,0	45,6	51,4	kW

* base unit without options and accessories

ACOUSTIC PERFORMANCES

Base acoustic setting up (AB)	60.2	70.2	80.2	90.2	100.2	
Sound power level	80	81	81	82	82	dB(A)
Sound pressure level at 1 metre	63	64	64	64	64	dB(A)
Sound pressure level at 5 metres	54	54	55	55	56	dB(A)
Sound pressure level at 10 metres	49	49	50	50	51	dB(A)
Low noise acoustic setting up (AS)	60.2	70.2	80.2	90.2	100.2	
Sound power level	77	78	78	79	79	dB(A)
Sound pressure level at 1 metre	60	61	61	61	61	dB(A)
Sound pressure level at 5 metres	51	51	52	52	53	dB(A)
Sound pressure level at 10 metres	46	46	47	47	48	dB(A)

The acoustic performances are referred to units operating in cooling mode at nominal conditions A7W35.

Unit placed in free field on reflecting surface (directional factor equal to 2).

The sound power level is measured according to ISO 3744 standard.

The sound pressure level is calculated according to ISO 3744 and is referred to a distance of 1/5/10 metres from the external surface of the unit.

DIMENSIONS AND MINIMUM OPERATING AREA

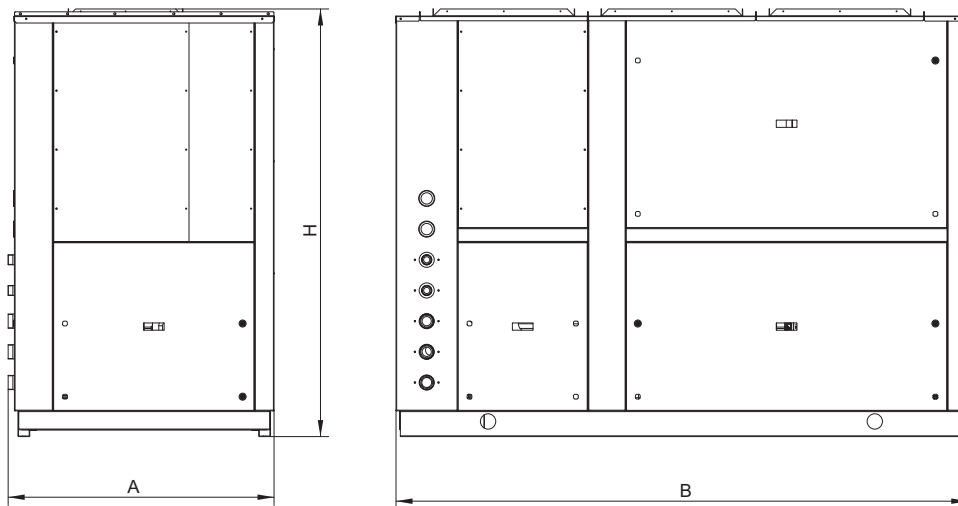

Respect the free area around the unit as shown in figure in order to guarantee a good accessibility and facilitate maintenance and control operations.

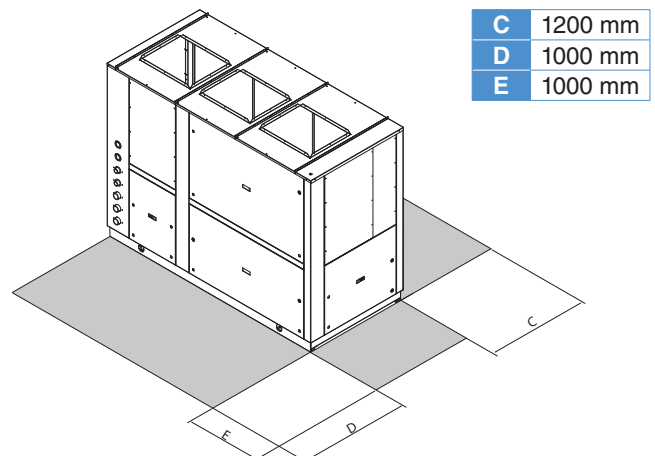

	60.2	70.2 - 80.2	90.2 - 100.2	
A	1130	1130	1130	mm
B	1710	2430	3130	mm
H	1810	1810	1810	mm

> HSW LT

WATER - WATER AND BRINE - WATER
HEAT PUMPS
FOR OUTDOOR OR INDOOR INSTALLATION

Available range

Unit type

- IH Heat pump
- IP Reversible heat pump
(reversible on the refrigerant side)

Versions

- VB Base version

Acoustic setting up

- AB Base setting up

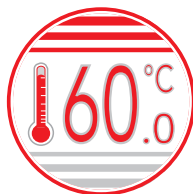

Efficiency class in heating mode - Average climate

Model	3.1	5.1	7.1	9.1	11.1
Efficiency class - medium temperature (water produce at 55°C)	A++	A++	A+	A+	A+
Efficiency class - low temperature (water produce at 35°C)	A++	A++	A++	A++	A++

NOTA: Declared according to **European regulation 811/2013**. The values are referred to units without options and accessories.

Unit description

This series of **water-water** heat pumps satisfies the heating, cooling and domestic hot water production requirements of residential plants of small and medium size.

All the units are suitable for outdoor or indoor installation and can be applied to **fan coil** plants, **radiant** floor plants and high efficiency **radiators** plants.

As source both water (from well, river, lake...) or brine solutions (from geothermic probes) can be used.

The control system allows to manage not only the refrigerant circuit but the whole plant with the possibility to choose different solutions both for the heating and cooling plant and for the domestic hot water management. The possibility of solar panels or other heating sources integration is also available.

The **heating** function optimizes the flow water temperature according both to the ambient temperature and to the outdoor temperature through climatic curves adaptable to the building features. It's possible to manage a storage tank and two independent circuits (a direct one and a mixed one).

The **domestic hot water** management allows to control the three way valve, the storage tank and the anti-legionella cycles (if necessary).

The **cooling** function can be realized through "passive cooling" (free cooling), through "active cooling" (refrigerant circuit inversion) or through both systems actuated in sequence. When the unit is used in radiant floor plants, to avoid condensate generation, a room humidity sensor can be installed.

The **internal programmer clock** allows to define different daily switching programs for heating, cooling and domestic hot water production.

The refrigerant circuit is equipped with rotary compressor mounted on damper supports, brazed plate heat exchangers, thermostatic expansion valve and reverse cycle valve (for reversible units). The circuit is protected by high and low pressure switches and flow switches on both the exchangers.

The outdoor structure is **thermally and acoustically insulated** in order to reduce sound propagation and to allow the installation in domestic places.

All the hydraulic pipes are thermally insulated to avoid condensate generation.

All the units are supplied with an outdoor temperature sensor in order to realize the climatic control.

All the units are accurately built and individually tested in the factory. Only electric and hydraulic connections are required for installation.

Options

Plant side flow rate management

- not present
- standard pump
- high head pump
- modulating pump

Soft starter

- not present
- standard

Accessories

- Rubber vibration dampers
- Spring vibration dampers
- Remote thermostat (wired or wireless)
- Remote control (wired or wireless)
- Wireless transmitter
- Wireless repeater
- Condensate sensor
- Room hygrometer
- Room humidity sensor
- Plant tank

CONTROL SYSTEM

The microprocessor controller is able to manage not only the unit itself but also all that components of the plant which allow to realize a complete system.

The main **functions** of the control system are :

- room temperature control according to the outdoor temperature (climatic control)
- domestic hot water production (management of 3 way valve, storage tank, anti legionella cycles...)
- management of a heating and/or cooling mixed circuit (pump and 3 way mixing valve)
- management of a heating direct circuit (only pump)
- management of a storage tank for heating and/or cooling
- management of electrical heaters for heating and domestic hot water (3 steps logic)
- solar panels integration
- passive cooling
- room humidity control for cooling with radiant systems
- internal programmer clock (for heating, cooling and domestic hot water)
- digital input for electrical energy low tariff
- alarm memory management and diagnostic
- compressor and pump operating hour counter
- possibility to manage more units in cascade (maximum 16)

Besides the standard user interface to be placed indoor, wired or wireless remote thermostats are available which allow to control all the operating parameters of the unit and to acquire the temperature in the different zones in order to realize a more precise and comfortable control.

The unit controller is able to manage a lot of different plant solutions enabling automatically the necessary control algorithms according to the components which have been connected.

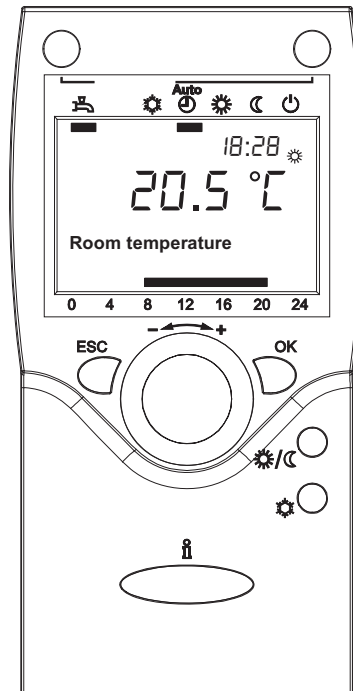

The management of such components is possible through additional expansion modules which communicate with the unit by means of an internal bus and provide all the inputs and outputs required to fulfil a complete system.

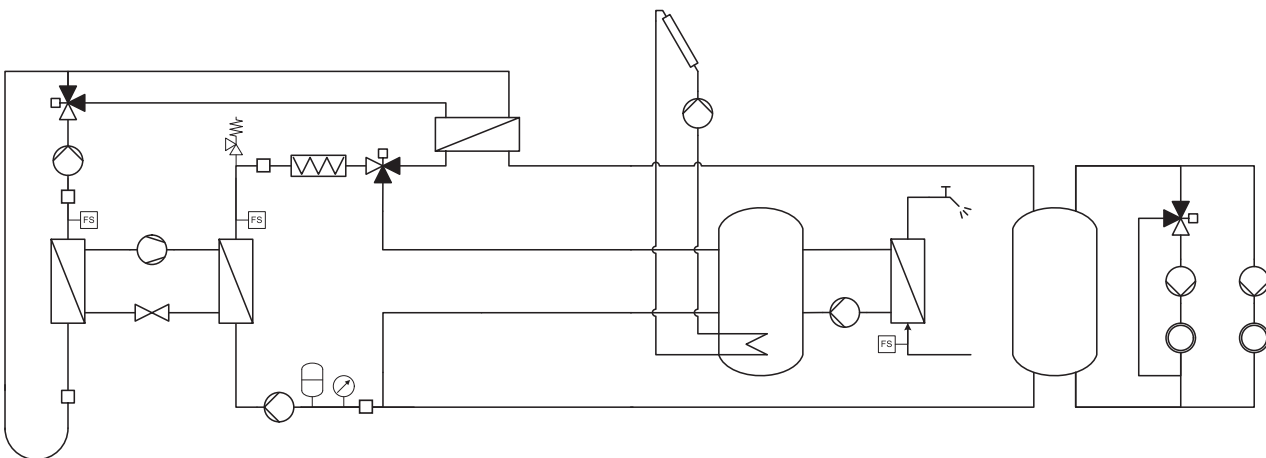

The controller is able to manage up to **two zones in heating** (one by means of a mixed circuit and the other by means of a direct circuit) and **one zone in cooling** (by means of a mixed circuit).

It's possible to realize more complex plants connecting to the heat pump controller further expansion modules in order to extend without limits the number of zones to be managed.

For each zone the following parameters can be set :

- set point
- daily or weekly operating time table
- climatic control curve
- room control sensor : it can be in common with the other zones or independent (in that case it's necessary to install an additional room thermostat)

OPERATING LIMITS	Unit type	Cooling		Heating		°C
		min	max	min	max	
Plant flow temperature	-	6	30	15	60	°C
Source return temperature (water)	-	5	45	5	25	°C
Source return temperature (brine)	-	-10	45	-10	25	°C

NOMINAL performances - Radiant plants

IP	Acoustic setting up : AB	3.1	5.1	7.1	9.1	11.1	
W10W35	Heating capacity	3,30	5,01	6,72	9,13	11,6	kW
	Power input	0,58	0,89	1,23	1,67	2,15	kW
	COP	5,69	5,63	5,46	5,47	5,40	-
	Water flow rate plant side	571	866	1160	1576	2009	l/h
	Pressure drops plant side	5	11	19	21	22	kPa
	Water flow rate source side	780	1181	1578	2147	2730	l/h
	Pressure drops source side	6	13	21	24	25	kPa
B0W35	Heating capacity	2,44	3,70	4,97	6,74	8,57	kW
	Power input	0,57	0,88	1,21	1,64	2,12	kW
	COP	4,28	4,20	4,11	4,11	4,04	-
	Water flow rate plant side	423	641	859	1165	1481	l/h
	Pressure drops plant side	2	7	11	13	13	kPa
	Water flow rate source side	595	900	1199	1632	2062	l/h
	Pressure drops source side	4	9	14	16	17	kPa
W30W18	Cooling capacity	3,59	5,43	7,27	9,87	12,6	kW
	Power input	0,59	0,90	1,25	1,69	2,17	kW
	EER	6,08	6,03	5,82	5,84	5,81	-
	Water flow rate plant side	619	938	1257	1709	2173	l/h
	Pressure drops plant side	6	13	21	24	25	kPa
	Water flow rate source side	722	1094	1470	1995	2541	l/h
	Pressure drops source side	6	12	19	21	22	kPa
B30W18	Cooling capacity	3,51	5,30	7,11	9,63	12,3	kW
	Power input	0,60	0,92	1,28	1,72	2,22	kW
	EER	5,85	5,76	5,55	5,60	5,54	-
	Water flow rate plant side	605	916	1229	1667	2121	l/h
	Pressure drops plant side	6	13	21	23	24	kPa
	Water flow rate source side	771	1166	1570	2127	2710	l/h
	Pressure drops source side	7	13	22	25	26	kPa

NOMINAL performances - Radiant plants

IH	Acoustic setting up : AB	3.1	5.1	7.1	9.1	11.1	
W10W35	Heating capacity	3,37	5,11	6,85	9,31	11,8	kW
	Power input	0,59	0,89	1,24	1,69	2,18	kW
	COP	5,71	5,74	5,52	5,51	5,41	-
	Water flow rate plant side	584	883	1183	1607	2043	l/h
	Pressure drops plant side	5	12	19	22	22	kPa
	Water flow rate source side	798	1209	1612	2193	2782	l/h
	Pressure drops source side	7	14	22	25	26	kPa
B0W35	Heating capacity	2,49	3,78	5,07	6,88	8,72	kW
	Power input	0,58	0,89	1,23	1,66	2,14	kW
	COP	4,29	4,25	4,12	4,14	4,07	-
	Water flow rate plant side	431	655	876	1190	1507	l/h
	Pressure drops plant side	3	7	12	13	13	kPa
	Water flow rate source side	608	923	1228	1670	2103	l/h
	Pressure drops source side	4	9	15	17	17	kPa

Data declared according to **EN 14511**. The values are referred to units without options or accessories. Brine = water with 30% ethylene glycol.

W10W65 = source: water in 10°C out 7°C / plant: water in 55°C out 65°C
 W10W55 = source: water in 10°C out 7°C / plant: water in 47°C out 55°C
 W10W45 = source: water in 10°C out 7°C / plant: water in 40°C out 45°C
 W10W35 = source: water in 10°C out 7°C / plant: water in 30°C out 35°C
 W30W7 = source: water in 30°C out 35°C / plant: water in 12°C out 7°C
 W30W18 = source: water in 30°C out 35°C / plant: water in 23°C out 18°C

B0W65 = source: brine in 0°C out -3°C / plant: water in 55°C out 65°C
 B0W55 = source: brine in 0°C out -3°C / plant: water in 47°C out 55°C
 B0W45 = source: brine in 0°C out -3°C / plant: water in 40°C out 45°C
 B0W35 = source: brine in 0°C out -3°C / plant: water in 30°C out 35°C
 B30W7 = source: brine in 30°C out 35°C / plant: water in 12°C out 7°C
 B30W18 = source: brine in 30°C out 35°C / plant: water in 23°C out 18°C

NOMINAL performances - Standard plants

IP	Acoustic setting up : AB	3.1	5.1	7.1	9.1	11.1	
W10W45	Heating capacity	3,03	4,61	6,19	8,40	10,6	kW
	Power input	0,71	1,09	1,50	2,02	2,59	kW
	COP	4,27	4,23	4,13	4,16	4,09	-
	Water flow rate plant side	527	799	1072	1456	1842	l/h
	Pressure drops plant side	4	10	16	18	19	kPa
	Water flow rate source side	666	1009	1347	1835	2310	l/h
	Pressure drops source side	5	10	16	19	19	kPa
B0W45	Heating capacity	2,27	3,44	4,62	6,27	7,96	kW
	Power input	0,69	1,06	1,46	1,96	2,53	kW
	COP	3,29	3,25	3,16	3,20	3,15	-
	Water flow rate plant side	395	598	801	1088	1382	l/h
	Pressure drops plant side	2	6	10	11	12	kPa
	Water flow rate source side	503	760	1009	1378	1737	l/h
	Pressure drops source side	3	6	11	12	13	kPa
W30W7	Cooling capacity	2,73	4,13	5,54	7,52	9,54	kW
	Power input	0,59	0,91	1,26	1,69	2,16	kW
	EER	4,63	4,54	4,40	4,45	4,42	-
	Water flow rate plant side	469	710	952	1294	1641	l/h
	Pressure drops plant side	3	8	13	15	16	kPa
	Water flow rate source side	575	873	1174	1592	2021	l/h
	Pressure drops source side	4	8	13	15	15	kPa
B30W7	Cooling capacity	2,67	4,05	5,42	7,35	9,33	kW
	Power input	0,60	0,92	1,28	1,72	2,21	kW
	EER	4,45	4,40	4,23	4,27	4,22	-
	Water flow rate plant side	458	695	932	1265	1605	l/h
	Pressure drops plant side	3	8	13	15	15	kPa
	Water flow rate source side	615	933	1256	1702	2162	l/h
	Pressure drops source side	4	9	15	17	18	kPa

NOMINAL performances - Standard plants

IH	Acoustic setting up : AB	3.1	5.1	7.1	9.1	11.1	
W10W45	Heating capacity	3,10	4,70	6,31	8,58	10,8	kW
	Power input	0,72	1,10	1,51	2,04	2,62	kW
	COP	4,31	4,27	4,18	4,21	4,12	-
	Water flow rate plant side	539	815	1093	1486	1877	l/h
	Pressure drops plant side	5	10	17	19	19	kPa
	Water flow rate source side	683	1032	1378	1878	2361	l/h
	Pressure drops source side	5	10	17	19	20	kPa
B0W45	Heating capacity	2,32	3,51	4,72	6,40	8,12	kW
	Power input	0,70	1,07	1,47	1,99	2,55	kW
	COP	3,31	3,28	3,21	3,22	3,18	-
	Water flow rate plant side	403	610	819	1111	1408	l/h
	Pressure drops plant side	2	6	10	12	12	kPa
	Water flow rate source side	515	779	1037	1409	1778	l/h
	Pressure drops source side	3	7	11	13	13	kPa

Data declared according to **EN 14511**. The values are referred to units without options or accessories. Brine = water with 30% ethylene glycol.

W10W65 = source: water in 10°C out 7°C / plant: water in 55°C out 65°C
 W10W55 = source: water in 10°C out 7°C / plant: water in 47°C out 55°C
 W10W45 = source: water in 10°C out 7°C / plant: water in 40°C out 45°C
 W10W35 = source: water in 10°C out 7°C / plant: water in 30°C out 35°C
 W30W7 = source: water in 30°C out 35°C / plant: water in 12°C out 7°C
 W30W18 = source: water in 30°C out 35°C / plant: water in 23°C out 18°C

B0W65 = source: brine in 0°C out -3°C / plant: water in 55°C out 65°C
 B0W55 = source: brine in 0°C out -3°C / plant: water in 47°C out 55°C
 B0W45 = source: brine in 0°C out -3°C / plant: water in 40°C out 45°C
 B0W35 = source: brine in 0°C out -3°C / plant: water in 30°C out 35°C
 B30W7 = source: brine in 30°C out 35°C / plant: water in 12°C out 7°C
 B30W18 = source: brine in 30°C out 35°C / plant: water in 23°C out 18°C

NOMINAL performances - HIGH temperature and plants

IP	Acoustic setting up : AB	3.1	5.1	7.1	9.1	11.1	
W10W55	Heating capacity	2,76	4,19	5,61	7,63	9,69	kW
	Power input	0,82	1,27	1,74	2,33	3,00	kW
	COP	3,37	3,30	3,22	3,27	3,23	-
	Water flow rate plant side	301	457	611	830	1055	l/h
	Pressure drops plant side	1	3	6	7	7	kPa
	Water flow rate source side	555	838	1112	1518	1918	l/h
	Pressure drops source side	3	7	12	14	14	kPa
B0W55	Heating capacity	2,10	3,19	4,28	5,81	7,37	kW
	Power input	0,79	1,21	1,67	2,24	2,89	kW
	COP	2,66	2,64	2,56	2,59	2,55	-
	Water flow rate plant side	229	348	466	633	803	l/h
	Pressure drops plant side	1	1	3	4	5	kPa
	Water flow rate source side	417	630	834	1139	1432	l/h
	Pressure drops source side	2	5	8	9	9	kPa

NOMINAL performances - HIGH temperature plants

IH	Acoustic setting up : AB	3.1	5.1	7.1	9.1	11.1	
W10W55	Heating capacity	2,82	4,27	5,72	7,78	9,85	kW
	Power input	0,84	1,28	1,75	2,37	3,03	kW
	COP	3,36	3,34	3,27	3,28	3,25	-
	Water flow rate plant side	307	465	623	847	1072	l/h
	Pressure drops plant side	1	3	6	7	8	kPa
	Water flow rate source side	566	858	1141	1552	1955	l/h
	Pressure drops source side	3	8	12	14	15	kPa
B0W55	Heating capacity	2,15	3,25	4,36	5,93	7,50	kW
	Power input	0,81	1,23	1,68	2,27	2,92	kW
	COP	2,65	2,64	2,60	2,61	2,57	-
	Water flow rate plant side	234	354	475	646	817	l/h
	Pressure drops plant side	1	1	3	4	5	kPa
	Water flow rate source side	426	643	856	1168	1463	l/h
	Pressure drops source side	2	5	8	9	10	kPa

TECHNICAL DATA	3.1	5.1	7.1	9.1	11.1	
Power supply	230 - 1 - 50					V-ph-Hz
Compressor type	rotary					-
N° compressors / N° refrigerant circuits	1 / 1					n°
Plant side heat exchanger type	stainless steel brazed plates					-
Source side heat exchanger type	stainless steel brazed plates					-
Hydraulic fittings	1" M					-
Weight *	91	101	103	112	115	kg
Maximum power input *	1,1	1,5	2,0	2,7	3,5	kW

* base unit without options and accessories

ACOUSTIC PERFORMANCES

Base acoustic setting up (AB)	3.1	5.1	7.1	9.1	11.1	
Sound power level	60	61	61	62	62	dB(A)
Sound pressure level at 1 metre	46	47	47	48	48	dB(A)
Sound pressure level at 5 metres	34	35	35	36	36	dB(A)
Sound pressure level at 10 metres	28	29	29	30	30	dB(A)

The acoustic performances are referred to units operating in cooling mode at nominal conditions W10W35.

Unit placed in free field on reflecting surface (directional factor equal to 2).

The sound power level is measured according to ISO 3744 standard.

The sound pressure level is calculated according to ISO 3744 and is referred to a distance of 1/5/10 metres from the external surface of the unit.

DIMENSIONS AND MINIMUM OPERATING AREA

Respect the free area around the unit as shown in figure in order to guarantee a good accessibility and facilitate maintenance and control operations.

A	600 mm
B	600 mm

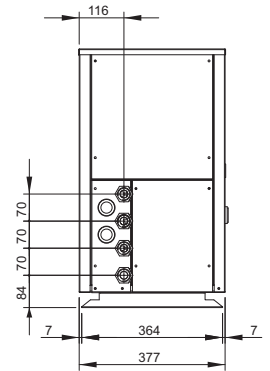
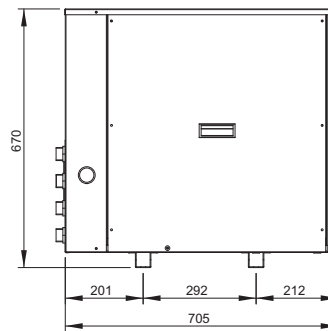
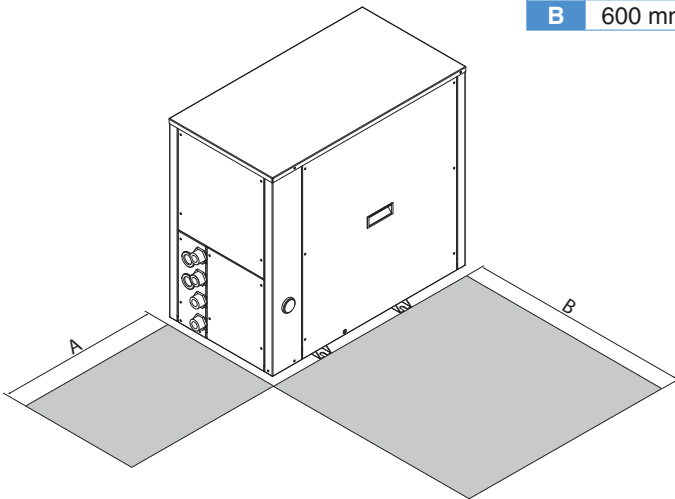

Unit with accessory
"Plant tank"

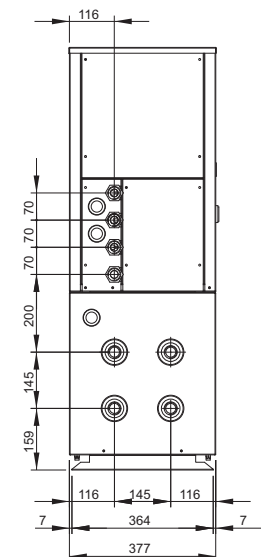
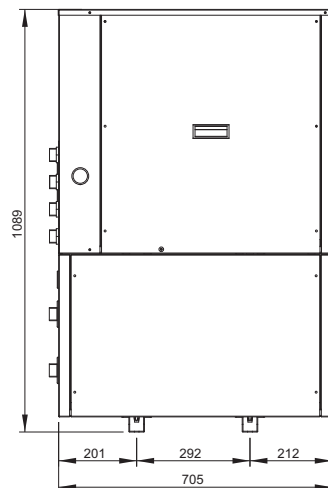
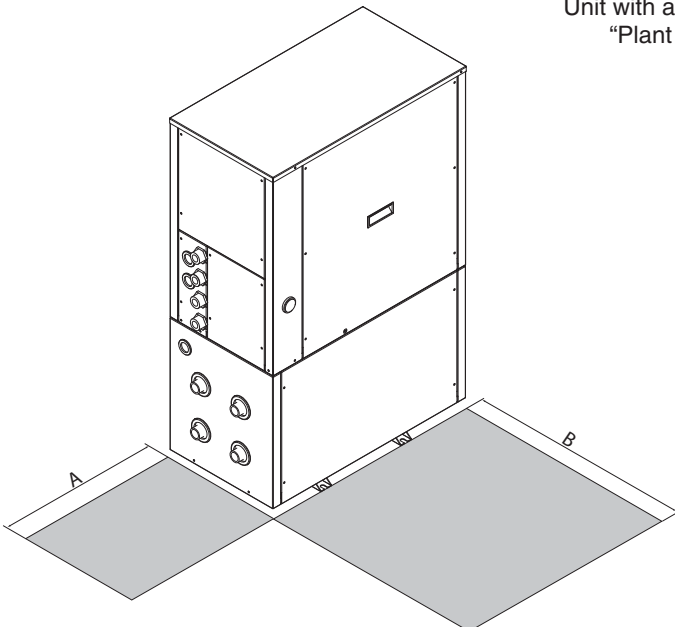

> HXW LT

WATER - WATER AND BRINE - WATER
HEAT PUMPS
FOR OUTDOOR OR INDOOR INSTALLATION

Available range

Unit type

- IH Heat pump
- IP Reversible heat pump
(reversible on the refrigerant side)

Versions

- VB Base version

Acoustic setting up

- AB Base setting up

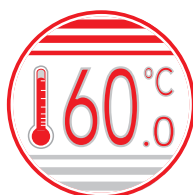

Efficiency class in heating mode - Average climate

Model	12.1	14.1	17.1	20.1	23.1	27.1
Efficiency class - medium temperature (water produce at 55°C)	A++	A+	A++	A+	A+	A+
Efficiency class - low temperature (water produce at 35°C)	A++	A++	A++	A++	A++	A++

NOTA: Declared according to **European regulation 811/2013**. The values are referred to units without options and accessories.

Unit description

This series of **water-water** heat pumps satisfies the heating, cooling and domestic hot water production requirements of residential plants of small and medium size.

All the units are suitable for outdoor or indoor installation and can be applied to **fan coil** plants, **radiant** floor plants and high efficiency **radiators** plants.

As source both water (from well, river, lake...) or brine solutions (from geothermic probes) can be used.

The control system allows to manage not only the refrigerant circuit but the whole plant with the possibility to choose different solutions both for the heating and cooling plant and for the domestic hot water management. The possibility of solar panels or other heating sources integration is also available.

The **heating** function optimizes the flow water temperature according both to the ambient temperature and to the outdoor temperature through climatic curves adaptable to the building features. It's possible to manage a storage tank and two independent circuits (a direct one and a mixed one).

The **domestic hot water** management allows to control the three way valve, the storage tank and the anti-legionella cycles (if necessary).

The **cooling** function can be realized

through "passive cooling" (free cooling), through "active cooling" (refrigerant circuit inversion) or through both systems actuated in sequence. When the unit is used in radiant floor plants, to avoid condensate generation, a room humidity sensor can be installed.

The **internal programmer clock** allows to define different daily switching programs for heating, cooling and domestic hot water production.

The refrigerant circuit is equipped with scroll compressor mounted on damper supports, brazed plate heat exchangers, thermostatic expansion valve and reverse cycle valve (for reversible units). The circuit is protected by high and low pressure switches and flow switches on both the exchangers.

The outdoor structure is **thermally and acoustically insulated** in order to reduce sound propagation and to allow the installation in domestic places.

All the hydraulic pipes are thermally insulated to avoid condensate generation.

All the three phase electrical power supply units are supplied with phase sequence and voltage controller and with an outdoor temperature sensor in order to realize the climatic control.

All the units are accurately built and individually tested in the factory. Only electric and hydraulic connections are required for installation.

Options

Plant side flow rate management

- not present
- standard pump
- high head pump
- modulating pump

Soft starter

- not present
- standard

Accessories

- Rubber vibration dampers
- Spring vibration dampers
- Remote thermostat (wired or wireless)
- Remote control (wired or wireless)
- Wireless transmitter
- Wireless repeater
- Condensate sensor
- Room hygostat
- Room humidity sensor
- Plant tank

CONTROL SYSTEM

The microprocessor controller is able to manage not only the unit itself but also all that components of the plant which allow to realize a complete system.

The main **functions** of the control system are :

- room temperature control according to the outdoor temperature (climatic control)
- domestic hot water production (management of 3 way valve, storage tank, anti legionella cycles...)
- management of a heating and/or cooling mixed circuit (pump and 3 way mixing valve)
- management of a heating direct circuit (only pump)
- management of a storage tank for heating and/or cooling
- management of electrical heaters for heating and domestic hot water (3 steps logic)
- solar panels integration
- passive cooling
- room humidity control for cooling with radiant systems
- internal programmer clock (for heating, cooling and domestic hot water)
- digital input for electrical energy low tariff
- alarm memory management and diagnostic
- compressor and pump operating hour counter
- possibility to manage more units in cascade (maximum 16)

Besides the standard user interface to be placed indoor, wired or wireless remote thermostats are available which allow to control all the operating parameters of the unit and to acquire the temperature in the different zones in order to realize a more precise and comfortable control.

The unit controller is able to manage a lot of different plant solutions enabling automatically the necessary control algorithms according to the components which have been connected.

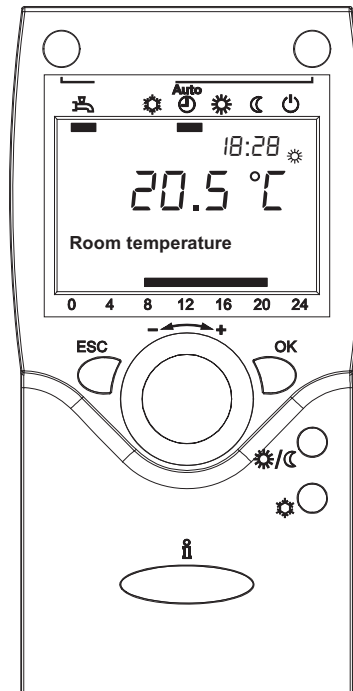

The management of such components is possible through additional expansion modules which communicate with the unit by means of an internal bus and provide all the inputs and outputs required to fulfil a complete system.

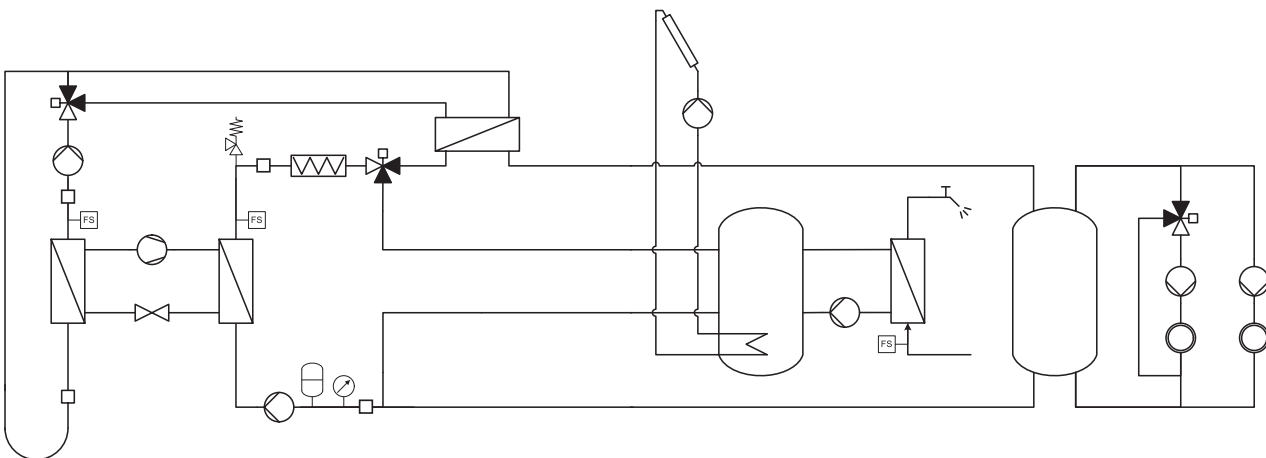

The controller is able to manage up to **two zones in heating** (one by means of a mixed circuit and the other by means of a direct circuit) and **one zone in cooling** (by means of a mixed circuit).

It's possible to realize more complex plants connecting to the heat pump controller further expansion modules in order to extend without limits the number of zones to be managed.

For each zone the following parameters can be set :

- set point
- daily or weekly operating time table
- climatic control curve
- room control sensor : it can be in common with the other zones or independent (in that case it's necessary to install an additional room thermostat)

OPERATING LIMITS	Unit type	Cooling		Heating		°C
		min	max	min	max	
Plant flow temperature	-	6	30	15	60	°C
Source return temperature (water)	-	5	45	5	25	°C
Source return temperature (brine)	-	-10	45	-10	25	°C

NOMINAL performances - Radiant plants

IP	Acoustic setting up : AB	12.1	14.1	17.1	20.1	23.1	27.1	
W10W35	Heating capacity	11,8	14,3	16,7	20,4	23,6	26,7	kW
	Power input	2,18	2,66	3,10	3,82	4,43	5,02	kW
	COP	5,41	5,38	5,39	5,34	5,33	5,32	-
	Water flow rate plant side	2043	2459	2892	3516	4070	4607	l/h
	Pressure drops plant side	17	24	18	27	22	27	kPa
	Water flow rate source side	2773	3336	3922	4774	5512	6255	l/h
	Pressure drops source side	17	24	20	29	25	32	kPa
B0W35	Heating capacity	8,71	10,6	12,4	15,0	17,4	19,7	kW
	Power input	2,15	2,62	3,07	3,73	4,35	4,90	kW
	COP	4,05	4,05	4,04	4,02	4,00	4,02	-
	Water flow rate plant side	1507	1836	2147	2598	3013	3412	l/h
	Pressure drops plant side	9	14	11	15	12	15	kPa
	Water flow rate source side	2093	2558	2987	3617	4180	4753	l/h
	Pressure drops source side	11	15	13	18	16	20	kPa
W30W18	Cooling capacity	12,8	15,4	18,1	22,0	25,4	28,8	kW
	Power input	2,21	2,70	3,14	3,87	4,50	5,09	kW
	EER	5,79	5,70	5,76	5,68	5,64	5,66	-
	Water flow rate plant side	2207	2673	3138	3811	4397	4983	l/h
	Pressure drops plant side	20	28	22	31	25	32	kPa
	Water flow rate source side	2586	3129	3675	4459	5159	5834	l/h
	Pressure drops source side	15	21	18	26	22	28	kPa
B30W18	Cooling capacity	12,5	15,1	17,7	21,6	24,9	28,3	kW
	Power input	2,25	2,76	3,22	3,96	4,59	5,21	kW
	EER	5,56	5,47	5,50	5,45	5,42	5,43	-
	Water flow rate plant side	2155	2621	3069	3742	4311	4897	l/h
	Pressure drops plant side	19	27	21	30	24	31	kPa
	Water flow rate source side	2759	3351	3926	4780	5521	6258	l/h
	Pressure drops source side	18	25	21	31	26	33	kPa

NOMINAL performances - Radiant plants

IH	Acoustic setting up : AB	12.1	14.1	17.1	20.1	23.1	27.1	
W10W35	Heating capacity	12,0	14,6	17,1	20,8	24,1	27,2	kW
	Power input	2,20	2,70	3,14	3,87	4,48	5,09	kW
	COP	5,45	5,41	5,45	5,37	5,38	5,34	-
	Water flow rate plant side	2078	2511	2944	3585	4156	4693	l/h
	Pressure drops plant side	17	25	19	28	22	28	kPa
	Water flow rate source side	2825	3413	3999	4877	5643	6384	l/h
	Pressure drops source side	18	25	21	30	26	33	kPa
B0W35	Heating capacity	8,81	10,8	12,7	15,3	17,7	20,1	kW
	Power input	2,17	2,65	3,10	3,77	4,40	4,95	kW
	COP	4,06	4,08	4,10	4,06	4,02	4,06	-
	Water flow rate plant side	1524	1870	2199	2650	3065	3464	l/h
	Pressure drops plant side	10	14	11	16	13	16	kPa
	Water flow rate source side	2119	2612	3073	3700	4263	4833	l/h
	Pressure drops source side	11	16	13	19	16	20	kPa

Data declared according to **EN 14511**. The values are referred to units without options or accessories. Brine = water with 30% ethylene glycol.

W10W65 = source: water in 10°C out 7°C / plant: water in 55°C out 65°C
 W10W55 = source: water in 10°C out 7°C / plant: water in 47°C out 55°C
 W10W45 = source: water in 10°C out 7°C / plant: water in 40°C out 45°C
 W10W35 = source: water in 10°C out 7°C / plant: water in 30°C out 35°C
 W30W7 = source: water in 30°C out 35°C / plant: water in 12°C out 7°C
 W30W18 = source: water in 30°C out 35°C / plant: water in 23°C out 18°C

B0W65 = source: brine in 0°C out -3°C / plant: water in 55°C out 65°C
 B0W55 = source: brine in 0°C out -3°C / plant: water in 47°C out 55°C
 B0W45 = source: brine in 0°C out -3°C / plant: water in 40°C out 45°C
 B0W35 = source: brine in 0°C out -3°C / plant: water in 30°C out 35°C
 B30W7 = source: brine in 30°C out 35°C / plant: water in 12°C out 7°C
 B30W18 = source: brine in 30°C out 35°C / plant: water in 23°C out 18°C

NOMINAL performances - Standard plants

IP	Acoustic setting up : AB	12.1	14.1	17.1	20.1	23.1	27.1	
W10W45	Heating capacity	10,8	13,1	15,4	18,8	21,7	24,6	kW
	Power input	2,63	3,21	3,76	4,58	5,34	6,02	kW
	COP	4,11	4,08	4,10	4,10	4,06	4,09	-
	Water flow rate plant side	1877	2277	2676	3250	3754	4258	l/h
	Pressure drops plant side	14	21	16	23	18	23	kPa
	Water flow rate source side	2350	2853	3353	4080	4688	5343	l/h
	Pressure drops source side	13	18	15	22	18	23	kPa
B0W45	Heating capacity	8,10	9,84	11,5	14,0	16,2	18,3	kW
	Power input	2,57	3,12	3,67	4,45	5,20	5,83	kW
	COP	3,15	3,15	3,13	3,15	3,12	3,14	-
	Water flow rate plant side	1406	1707	1999	2433	2815	3180	l/h
	Pressure drops plant side	8	12	9	13	11	13	kPa
	Water flow rate source side	1763	2144	2504	3061	3519	3996	l/h
	Pressure drops source side	8	11	9	13	11	14	kPa
W30W7	Cooling capacity	9,71	11,8	13,8	16,8	19,4	21,9	kW
	Power input	2,21	2,68	3,14	3,82	4,47	5,02	kW
	EER	4,39	4,40	4,39	4,40	4,34	4,36	-
	Water flow rate plant side	1670	2025	2368	2883	3329	3775	l/h
	Pressure drops plant side	12	17	13	18	15	19	kPa
	Water flow rate source side	2061	2497	2923	3554	4116	4655	l/h
	Pressure drops source side	10	14	12	17	14	18	kPa
B30W7	Cooling capacity	9,50	11,6	13,6	16,5	19,1	21,5	kW
	Power input	2,25	2,74	3,21	3,91	4,56	5,14	kW
	EER	4,22	4,23	4,24	4,22	4,19	4,18	-
	Water flow rate plant side	1634	1991	2334	2832	3278	3707	l/h
	Pressure drops plant side	11	16	12	18	14	18	kPa
	Water flow rate source side	2206	2683	3148	3815	4428	4998	l/h
	Pressure drops source side	12	17	14	20	17	22	kPa

NOMINAL performances - Standard plants

IH	Acoustic setting up : AB	12.1	14.1	17.1	20.1	23.1	27.1	
W10W45	Heating capacity	11,0	13,4	15,7	19,2	22,2	25,0	kW
	Power input	2,67	3,26	3,80	4,64	5,40	6,09	kW
	COP	4,12	4,11	4,13	4,14	4,11	4,11	-
	Water flow rate plant side	1912	2329	2729	3319	3841	4327	l/h
	Pressure drops plant side	15	22	16	24	19	24	kPa
	Water flow rate source side	2399	2927	3428	4180	4817	5440	l/h
	Pressure drops source side	13	19	16	23	19	24	kPa
B0W45	Heating capacity	8,21	10,0	11,8	14,3	16,5	18,6	kW
	Power input	2,59	3,16	3,70	4,49	5,26	5,90	kW
	COP	3,17	3,16	3,19	3,18	3,14	3,15	-
	Water flow rate plant side	1425	1738	2051	2485	2868	3233	l/h
	Pressure drops plant side	8	12	10	14	11	14	kPa
	Water flow rate source side	1791	2189	2590	3143	3598	4072	l/h
	Pressure drops source side	8	12	10	14	12	15	kPa

Data declared according to **EN 14511**. The values are referred to units without options or accessories. Brine = water with 30% ethylene glycol.

W10W65 = source: water in 10°C out 7°C / plant: water in 55°C out 65°C
 W10W55 = source: water in 10°C out 7°C / plant: water in 47°C out 55°C
 W10W45 = source: water in 10°C out 7°C / plant: water in 40°C out 45°C
 W10W35 = source: water in 10°C out 7°C / plant: water in 30°C out 35°C
 W30W7 = source: water in 30°C out 35°C / plant: water in 12°C out 7°C
 W30W18 = source: water in 30°C out 35°C / plant: water in 23°C out 18°C

B0W65 = source: brine in 0°C out -3°C / plant: water in 55°C out 65°C
 B0W55 = source: brine in 0°C out -3°C / plant: water in 47°C out 55°C
 B0W45 = source: brine in 0°C out -3°C / plant: water in 40°C out 45°C
 B0W35 = source: brine in 0°C out -3°C / plant: water in 30°C out 35°C
 B30W7 = source: brine in 30°C out 35°C / plant: water in 12°C out 7°C
 B30W18 = source: brine in 30°C out 35°C / plant: water in 23°C out 18°C

NOMINAL performances - HIGH temperature and plants

IP	Acoustic setting up : AB	12.1	14.1	17.1	20.1	23.1	27.1	
W10W55	Heating capacity	9,84	11,9	14,0	17,0	19,7	22,3	kW
	Power input	3,07	3,72	4,36	5,28	6,19	6,94	kW
	COP	3,21	3,20	3,21	3,22	3,18	3,21	-
	Water flow rate plant side	1072	1297	1525	1852	2147	2430	l/h
	Pressure drops plant side	5	7	5	8	6	8	kPa
	Water flow rate source side	1941	2350	2764	3368	3879	4417	l/h
	Pressure drops source side	9	13	10	15	13	16	kPa
B0W55	Heating capacity	7,50	9,10	10,6	13,0	15,0	17,0	kW
	Power input	2,95	3,57	4,20	5,08	5,95	6,66	kW
	COP	2,54	2,55	2,52	2,56	2,52	2,55	-
	Water flow rate plant side	817	992	1155	1417	1634	1852	l/h
	Pressure drops plant side	3	4	3	5	4	5	kPa
	Water flow rate source side	1451	1766	2042	2529	2889	3302	l/h
	Pressure drops source side	5	8	6	9	8	10	kPa

NOMINAL performances - HIGH temperature plants

IH	Acoustic setting up : AB	12.1	14.1	17.1	20.1	23.1	27.1	
W10W55	Heating capacity	10,0	12,2	14,3	17,3	20,1	22,7	kW
	Power input	3,09	3,76	4,41	5,34	6,25	7,01	kW
	COP	3,24	3,24	3,24	3,24	3,22	3,24	-
	Water flow rate plant side	1090	1329	1558	1885	2190	2473	l/h
	Pressure drops plant side	5	7	6	8	7	8	kPa
	Water flow rate source side	1981	2424	2839	3436	3977	4511	l/h
	Pressure drops source side	9	13	11	16	13	17	kPa
B0W55	Heating capacity	7,60	9,30	10,9	13,2	15,3	17,3	kW
	Power input	2,98	3,62	4,24	5,13	6,01	6,73	kW
	COP	2,55	2,57	2,57	2,57	2,55	2,57	-
	Water flow rate plant side	828	1013	1188	1438	1667	1885	l/h
	Pressure drops plant side	3	4	3	5	4	5	kPa
	Water flow rate source side	1473	1813	2125	2577	2965	3375	l/h
	Pressure drops source side	5	8	7	10	8	10	kPa

TECHNICAL DATA	12.1	14.1	17.1	20.1	23.1	27.1	
Power supply	230-1-50 400-3N-50				400-3N-50		V-ph-Hz
Compressor type	scroll						-
N° compressors / N° refrigerant circuits	1 / 1						n°
Plant side heat exchanger type	stainless steel brazed plates						-
Source side heat exchanger type	stainless steel brazed plates						-
Hydraulic fittings	1" M						-
Weight *	138	141	160	162	165	168	kg
Maximum power input *	3,5	4,5	5,1	5,8	6,8	7,6	kW

* base unit without options and accessories

ACOUSTIC PERFORMANCES

Base acoustic setting up (AB)	12.1	14.1	17.1	20.1	23.1	27.1	
Sound power level	63	63	64	64	65	65	dB(A)
Sound pressure level at 1 metre	50	50	51	51	52	52	dB(A)
Sound pressure level at 5 metres	38	38	39	39	40	40	dB(A)
Sound pressure level at 10 metres	32	32	33	33	34	34	dB(A)

The acoustic performances are referred to units operating in cooling mode at nominal conditions W10W35.

Unit placed in free field on reflecting surface (directional factor equal to 2).

The sound power level is measured according to ISO 3744 standard.

The sound pressure level is calculated according to ISO 3744 and is referred to a distance of 1/5/10 metres from the external surface of the unit.

DIMENSIONS AND MINIMUM OPERATING AREA

Respect the free area around the unit as shown in figure in order to guarantee a good accessibility and facilitate maintenance and control operations.

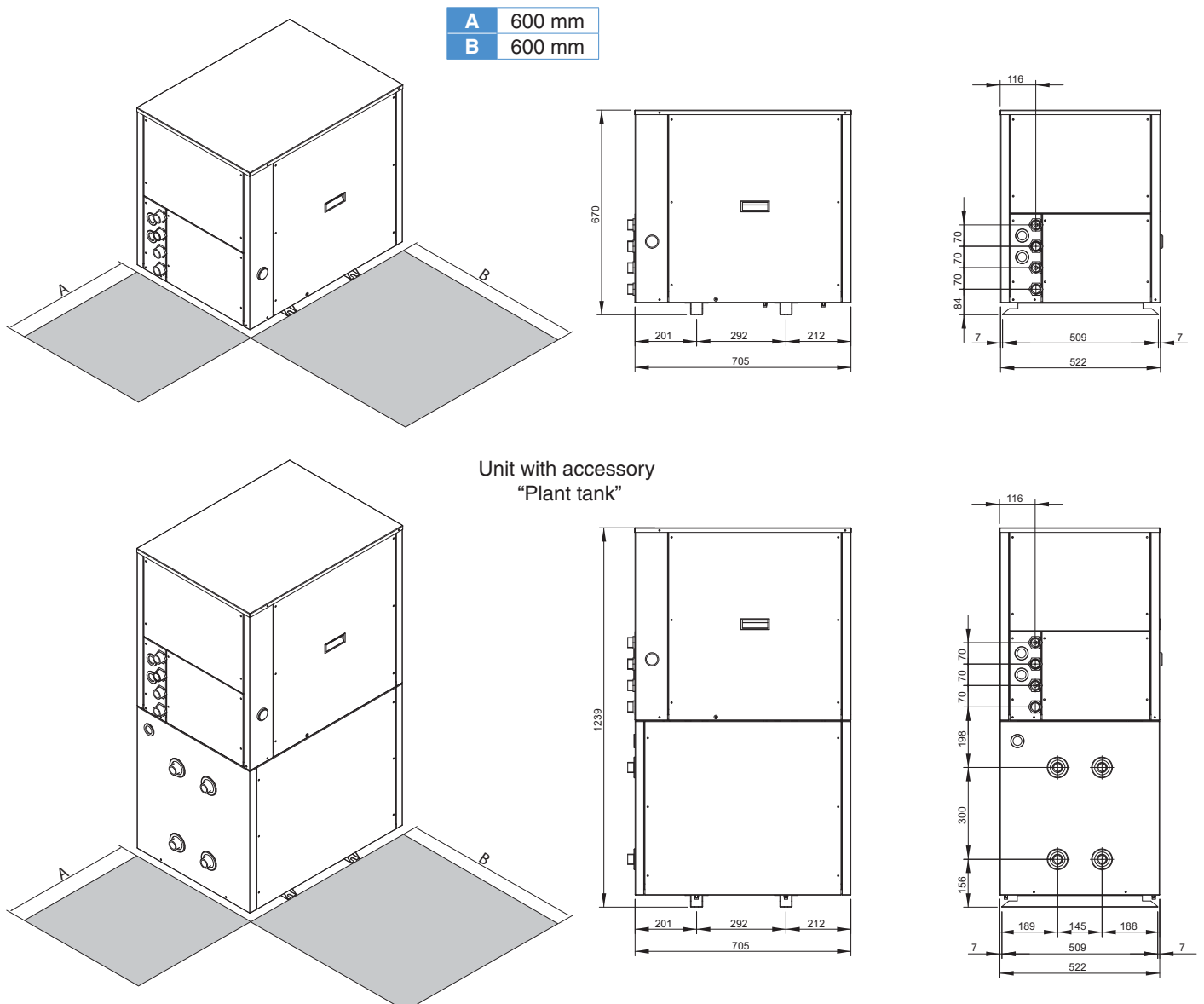

> HMW LT

WATER - WATER AND BRINE - WATER
HEAT PUMPS
FOR OUTDOOR OR INDOOR INSTALLATION

Available range

Unit type

- IH Heat pump
- IP Reversible heat pump
(reversible on the refrigerant side)

Versions

- VB Base version

Acoustic setting up

- AB Base setting up

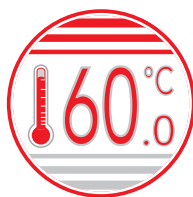

Efficiency class in heating mode - Average climate

Model	30.1	35.1	40.1	45.1	50.1	55.1
Efficiency class - medium temperature (water produce at 55°C)	A++	A++	A++	A++	A++	A++
Efficiency class - low temperature (water produce at 35°C)	A++	A++	A++	A++	A++	A++

NOTA: Declared according to **European regulation 811/2013**. The values are referred to units without options and accessories.

Unit description

This series of **water-water** heat pumps satisfies the heating, cooling and domestic hot water production requirements of residential plants of small and medium size.

All the units are suitable for indoor installation and can be applied to **fan coil** plants, **radiant** floor plants and high efficiency **radiators** plants.

As source both water (from well, river, lake...) or brine solutions (from geothermic probes) can be used.

The control system allows to manage not only the refrigerant circuit but the whole plant with the possibility to choose different solutions both for the heating and cooling plant and for the domestic hot water management. The possibility of solar panels or other heating sources integration is also available.

The **heating** function optimizes the flow water temperature according both to the ambient temperature and to the outdoor temperature through climatic curves adaptable to the building features. It's possible to manage a storage tank and two independent circuits (a direct one and a mixed one).

The **domestic hot water** management allows to control the three way valve, the storage tank and the anti-legionella cycles (if necessary).

The **cooling** function can be realized

through "passive cooling" (free cooling), through "active cooling" (refrigerant circuit inversion) or through both systems actuated in sequence. When the unit is used in radiant floor plants, to avoid condensate generation, a room humidity sensor can be installed.

The **internal programmer clock** allows to define different daily switching programs for heating, cooling and domestic hot water production.

The refrigerant circuit is equipped with scroll compressor mounted on damper supports, brazed plate heat exchangers, electronic expansion valve and reverse cycle valve (for reversible units). The circuit is protected by high and low pressure switches and flow switches on both the exchangers.

The outdoor structure is **thermally and acoustically insulated** in order to reduce sound propagation and to allow the installation in domestic places.

All the hydraulic pipes are thermally insulated to avoid condensate generation.

All the units are supplied with phase sequence and voltage controller and with an outdoor temperature sensor in order to realize the climatic control.

All the units are accurately built and individually tested in the factory. Only electric and hydraulic connections are required for installation.

Options

Plant side flow rate management

- not present
- standard pump
- high head pump
- modulating pump

Soft starter

- not present
- standard

Accessories

- Rubber vibration dampers
- Spring vibration dampers
- Remote thermostat (wired or wireless)
- Remote control (wired or wireless)
- Wireless transmitter
- Wireless repeater
- Condensate sensor
- Room hygostat
- Room humidity sensor
- Plant tank

CONTROL SYSTEM

The microprocessor controller is able to manage not only the unit itself but also all that components of the plant which allow to realize a complete system.

The main **functions** of the control system are :

- room temperature control according to the outdoor temperature (climatic control)
- domestic hot water production (management of 3 way valve, storage tank, anti legionella cycles...)
- management of a heating and/or cooling mixed circuit (pump and 3 way mixing valve)
- management of a heating direct circuit (only pump)
- management of a storage tank for heating and/or cooling
- management of electrical heaters for heating and domestic hot water (3 steps logic)
- solar panels integration
- passive cooling
- room humidity control for cooling with radiant systems
- internal programmer clock (for heating, cooling and domestic hot water)
- digital input for electrical energy low tariff
- alarm memory management and diagnostic
- compressor and pump operating hour counter
- possibility to manage more units in cascade (maximum 16)

Besides the standard user interface to be placed indoor, wired or wireless remote thermostats are available which allow to control all the operating parameters of the unit and to acquire the temperature in the different zones in order to realize a more precise and comfortable control.

The unit controller is able to manage a lot of different plant solutions enabling automatically the necessary control algorithms according to the components which have been connected.

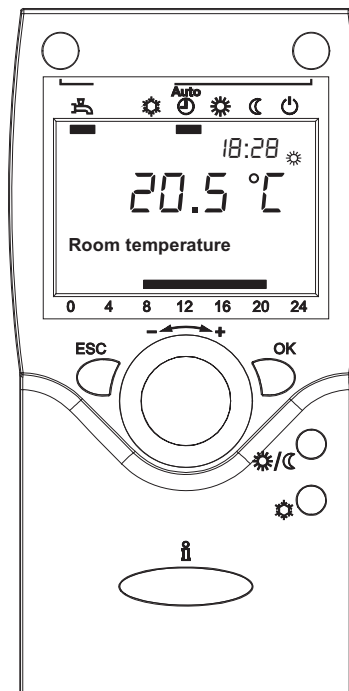

The management of such components is possible through additional expansion modules which communicate with the unit by means of an internal bus and provide all the inputs and outputs required to fulfil a complete system.

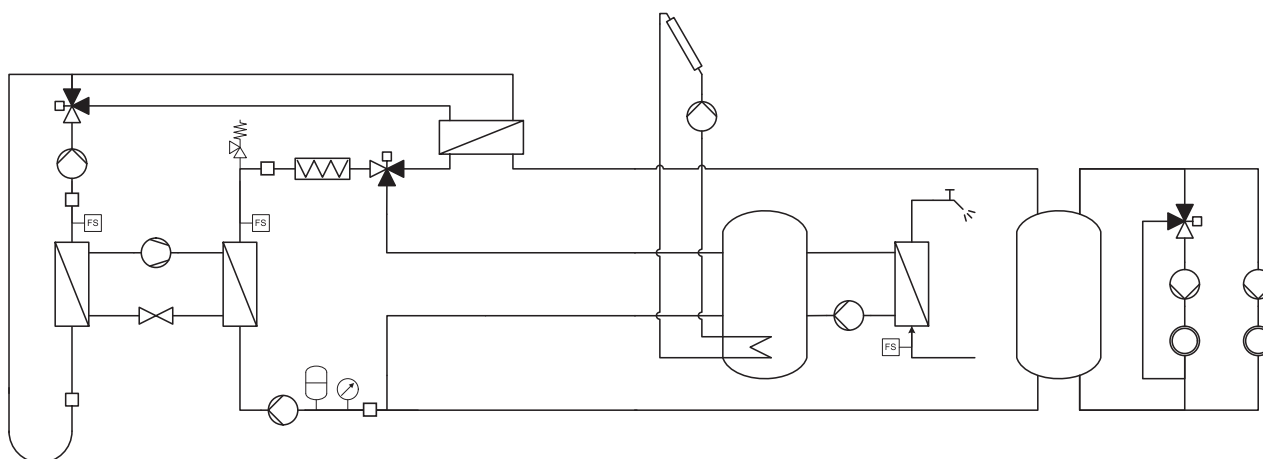

The controller is able to manage up to **two zones in heating** (one by means of a mixed circuit and the other by means of a direct circuit) and **one zone in cooling** (by means of a mixed circuit).

It's possible to realize more complex plants connecting to the heat pump controller further expansion modules in order to extend without limits the number of zones to be managed.

For each zone the following parameters can be set :

- set point
- daily or weekly operating time table
- climatic control curve
- room control sensor : it can be in common with the other zones or independent (in that case it's necessary to install an additional room thermostat)

OPERATING LIMITS	Unit type	Cooling		Heating		°C
		min	max	min	max	
Plant flow temperature	-	6	30	15	60	°C
Source return temperature (water)	-	5	45	5	25	°C
Source return temperature (brine)	-	-10	45	-10	25	°C

NOMINAL performances - Radiant plants

IP	Acoustic setting up : AB	30.1	35.1	40.1	45.1	50.1	55.1	
W10W35	Heating capacity	28,2	32,4	38,2	42,7	48,1	56,4	kW
	Power input	5,13	5,93	7,01	7,90	8,86	10,5	kW
	COP	5,50	5,46	5,45	5,41	5,43	5,37	-
	Water flow rate plant side	4866	5594	6598	7360	8295	9715	l/h
	Pressure drops plant side	20	26	24	29	28	38	kPa
	Water flow rate source side	6655	7670	9031	10089	11378	13368	l/h
	Pressure drops source side	36	47	43	53	51	70	kPa
B0W35	Heating capacity	21,6	24,9	29,4	32,9	37,0	43,4	kW
	Power input	5,02	5,76	6,84	7,64	8,57	10,1	kW
	COP	4,30	4,32	4,30	4,31	4,32	4,30	-
	Water flow rate plant side	3741	4295	5074	5680	6390	7481	l/h
	Pressure drops plant side	12	16	14	18	17	23	kPa
	Water flow rate source side	5326	6134	7231	8122	9140	10744	l/h
	Pressure drops source side	25	32	30	37	36	48	kPa
W30W18	Cooling capacity	30,5	34,9	41,2	46,0	51,8	60,6	kW
	Power input	5,18	5,97	7,07	7,95	8,90	10,6	kW
	EER	5,89	5,85	5,83	5,79	5,82	5,72	-
	Water flow rate plant side	5276	6052	7138	7983	8983	10518	l/h
	Pressure drops plant side	23	30	28	34	33	44	kPa
	Water flow rate source side	6146	7040	8314	9284	10444	12204	l/h
	Pressure drops source side	30	39	37	45	43	58	kPa
B30W18	Cooling capacity	30,1	34,5	40,8	45,6	51,3	60,1	kW
	Power input	5,22	6,04	7,15	8,06	9,02	10,7	kW
	EER	5,77	5,71	5,71	5,66	5,69	5,62	-
	Water flow rate plant side	5207	5983	7069	7897	8897	10431	l/h
	Pressure drops plant side	22	29	27	33	32	43	kPa
	Water flow rate source side	6598	7569	8953	9987	11247	13157	l/h
	Pressure drops source side	36	47	44	54	52	70	kPa

NOMINAL performances - Radiant plants

IH	Acoustic setting up : AB	30.1	35.1	40.1	45.1	50.1	55.1	
W10W35	Heating capacity	28,8	33,0	39,0	43,6	49,1	57,6	kW
	Power input	5,20	6,02	7,11	8,02	8,99	10,7	kW
	COP	5,54	5,48	5,49	5,44	5,46	5,38	-
	Water flow rate plant side	4970	5698	6719	7516	8468	9906	l/h
	Pressure drops plant side	20	26	24	30	29	39	kPa
	Water flow rate source side	6813	7825	9211	10326	11641	13657	l/h
	Pressure drops source side	37	48	45	56	54	73	kPa
B0W35	Heating capacity	22,1	25,4	30,0	33,6	37,8	44,2	kW
	Power input	5,09	5,84	6,92	7,74	8,68	10,2	kW
	COP	4,34	4,35	4,34	4,34	4,35	4,33	-
	Water flow rate plant side	3827	4381	5178	5801	6529	7620	l/h
	Pressure drops plant side	12	16	15	19	18	24	kPa
	Water flow rate source side	5469	6274	7400	8323	9369	10970	l/h
	Pressure drops source side	26	34	31	39	37	50	kPa

Data declared according to **EN 14511**. The values are referred to units without options or accessories. Brine = water with 30% ethylene glycol.

W10W65 = source: water in 10°C out 7°C / plant: water in 55°C out 65°C
 W10W55 = source: water in 10°C out 7°C / plant: water in 47°C out 55°C
 W10W45 = source: water in 10°C out 7°C / plant: water in 40°C out 45°C
 W10W35 = source: water in 10°C out 7°C / plant: water in 30°C out 35°C
 W30W7 = source: water in 30°C out 35°C / plant: water in 12°C out 7°C
 W30W18 = source: water in 30°C out 35°C / plant: water in 23°C out 18°C

B0W65 = source: brine in 0°C out -3°C / plant: water in 55°C out 65°C
 B0W55 = source: brine in 0°C out -3°C / plant: water in 47°C out 55°C
 B0W45 = source: brine in 0°C out -3°C / plant: water in 40°C out 45°C
 B0W35 = source: brine in 0°C out -3°C / plant: water in 30°C out 35°C
 B30W7 = source: brine in 30°C out 35°C / plant: water in 12°C out 7°C
 B30W18 = source: brine in 30°C out 35°C / plant: water in 23°C out 18°C

NOMINAL performances - Standard plants

IP	Acoustic setting up : AB	30.1	35.1	40.1	45.1	50.1	55.1	
W10W45	Heating capacity	26,0	29,8	35,1	39,3	44,3	51,9	kW
	Power input	6,14	7,05	8,35	9,34	10,50	12,3	kW
	COP	4,23	4,23	4,20	4,21	4,22	4,22	-
	Water flow rate plant side	4501	5162	6083	6795	7664	8968	l/h
	Pressure drops plant side	17	22	20	25	24	32	kPa
	Water flow rate source side	5709	6567	7716	8642	9757	11464	l/h
	Pressure drops source side	27	35	32	40	38	52	kPa
B0W45	Heating capacity	20,1	23,2	27,3	30,6	34,4	40,3	kW
	Power input	5,97	6,82	8,10	9,01	10,1	11,8	kW
	COP	3,37	3,40	3,37	3,40	3,41	3,42	-
	Water flow rate plant side	3493	4015	4727	5301	5961	6986	l/h
	Pressure drops plant side	10	14	13	16	15	20	kPa
	Water flow rate source side	4530	5233	6134	6916	7779	9163	l/h
	Pressure drops source side	18	24	22	27	26	36	kPa
W30W7	Cooling capacity	23,2	26,6	31,4	35,2	39,6	46,2	kW
	Power input	5,13	5,87	6,96	7,77	8,71	10,2	kW
	EER	4,52	4,53	4,51	4,53	4,55	4,53	-
	Water flow rate plant side	3999	4582	5406	6058	6813	7963	l/h
	Pressure drops plant side	14	18	16	20	19	26	kPa
	Water flow rate source side	4899	5604	6621	7403	8325	9707	l/h
	Pressure drops source side	20	26	24	29	28	38	kPa
B30W7	Cooling capacity	23,0	26,3	31,1	34,8	39,2	45,9	kW
	Power input	5,15	5,90	7,00	7,82	8,77	10,3	kW
	EER	4,47	4,46	4,44	4,45	4,47	4,46	-
	Water flow rate plant side	3947	4531	5354	5989	6744	7911	l/h
	Pressure drops plant side	13	17	16	20	19	26	kPa
	Water flow rate source side	5263	6029	7132	7963	8964	10483	l/h
	Pressure drops source side	24	31	29	35	34	46	kPa

NOMINAL performances - Standard plants

IH	Acoustic setting up : AB	30.1	35.1	40.1	45.1	50.1	55.1	
W10W45	Heating capacity	26,5	30,4	35,9	40,2	45,2	52,9	kW
	Power input	6,21	7,14	8,47	9,47	10,7	12,5	kW
	COP	4,27	4,26	4,24	4,24	4,22	4,23	-
	Water flow rate plant side	4588	5266	6222	6952	7821	9141	l/h
	Pressure drops plant side	17	23	21	26	25	34	kPa
	Water flow rate source side	5835	6718	7919	8874	9977	11721	l/h
	Pressure drops source side	28	36	34	42	40	54	kPa
B0W45	Heating capacity	20,6	23,6	27,9	31,2	35,1	41,0	kW
	Power input	6,04	6,90	8,19	9,12	10,2	12,0	kW
	COP	3,41	3,42	3,41	3,42	3,44	3,42	-
	Water flow rate plant side	3580	4084	4831	5405	6083	7108	l/h
	Pressure drops plant side	11	14	13	16	16	21	kPa
	Water flow rate source side	4670	5338	6299	7079	7969	9353	l/h
	Pressure drops source side	19	25	23	29	28	37	kPa

Data declared according to **EN 14511**. The values are referred to units without options or accessories. Brine = water with 30% ethylene glycol.

W10W65 = source: water in 10°C out 7°C / plant: water in 55°C out 65°C
 W10W55 = source: water in 10°C out 7°C / plant: water in 47°C out 55°C
 W10W45 = source: water in 10°C out 7°C / plant: water in 40°C out 45°C
 W10W35 = source: water in 10°C out 7°C / plant: water in 30°C out 35°C
 W30W7 = source: water in 30°C out 35°C / plant: water in 12°C out 7°C
 W30W18 = source: water in 30°C out 35°C / plant: water in 23°C out 18°C

B0W65 = source: brine in 0°C out -3°C / plant: water in 55°C out 65°C
 B0W55 = source: brine in 0°C out -3°C / plant: water in 47°C out 55°C
 B0W45 = source: brine in 0°C out -3°C / plant: water in 40°C out 45°C
 B0W35 = source: brine in 0°C out -3°C / plant: water in 30°C out 35°C
 B30W7 = source: brine in 30°C out 35°C / plant: water in 12°C out 7°C
 B30W18 = source: brine in 30°C out 35°C / plant: water in 23°C out 18°C

NOMINAL performances - HIGH temperature and plants

IP	Acoustic setting up : AB	30.1	35.1	40.1	45.1	50.1	55.1	
W10W55	Heating capacity	23,5	27,0	31,9	35,6	40,1	47,1	kW
	Power input	7,09	8,07	9,61	10,7	12,0	14,0	kW
	COP	3,31	3,35	3,32	3,33	3,34	3,36	-
	Water flow rate plant side	2561	2942	3476	3879	4369	5121	l/h
	Pressure drops plant side	6	7	7	9	8	11	kPa
	Water flow rate source side	4717	5452	6418	7176	8090	9548	l/h
	Pressure drops source side	19	24	23	28	27	37	kPa
B0W55	Heating capacity	18,6	21,4	25,2	28,3	31,8	37,3	kW
	Power input	6,81	7,75	9,21	10,2	11,5	13,3	kW
	COP	2,73	2,76	2,74	2,77	2,77	2,80	-
	Water flow rate plant side	2027	2332	2746	3084	3465	4064	l/h
	Pressure drops plant side	4	5	4	6	5	7	kPa
	Water flow rate source side	3767	4368	5113	5790	6490	7699	l/h
	Pressure drops source side	13	17	15	20	19	26	kPa

NOMINAL performances - HIGH temperature plants

IH	Acoustic setting up : AB	30.1	35.1	40.1	45.1	50.1	55.1	
W10W55	Heating capacity	24,0	27,5	32,5	36,4	41,0	48,0	kW
	Power input	7,17	8,17	9,72	10,8	12,2	14,1	kW
	COP	3,35	3,37	3,34	3,37	3,36	3,40	-
	Water flow rate plant side	2615	2996	3541	3966	4468	5219	l/h
	Pressure drops plant side	6	8	7	9	9	12	kPa
	Water flow rate source side	4840	5569	6561	7376	8319	9777	l/h
	Pressure drops source side	20	25	24	29	28	39	kPa
B0W55	Heating capacity	19,1	21,8	25,8	28,9	32,5	38,0	kW
	Power input	6,89	7,83	9,32	10,3	11,6	13,4	kW
	COP	2,77	2,78	2,77	2,81	2,80	2,84	-
	Water flow rate plant side	2081	2375	2811	3149	3541	4141	l/h
	Pressure drops plant side	4	5	5	6	6	8	kPa
	Water flow rate source side	3904	4470	5272	5949	6681	7890	l/h
	Pressure drops source side	14	18	16	21	20	27	kPa

TECHNICAL DATA	30.1	35.1	40.1	45.1	50.1	55.1	
Power supply	400-3N-50						V-ph-Hz
Compressor type	scroll						-
N° compressors / N° refrigerant circuits	1 / 1						n°
Plant side heat exchanger type	stainless steel brazed plates						-
Source side heat exchanger type	stainless steel brazed plates						-
Hydraulic fittings	1"1/4 M						-
Weight *	254	272	282	282	294	295	kg
Maximum power input *	10,2	11,5	12,8	14,0	16,6	19,2	kW

* base unit without options and accessories

ACOUSTIC PERFORMANCES

Base acoustic setting up (AB)	30.1	35.1	40.1	45.1	50.1	55.1	
Sound power level	65	66	67	68	69	70	dB(A)
Sound pressure level at 1 metre	51	52	53	54	55	56	dB(A)
Sound pressure level at 5 metres	40	41	42	43	44	45	dB(A)
Sound pressure level at 10 metres	34	35	36	37	38	39	dB(A)

The acoustic performances are referred to units operating in cooling mode at nominal conditions W10W35.

Unit placed in free field on reflecting surface (directional factor equal to 2).

The sound power level is measured according to ISO 3744 standard.

The sound pressure level is calculated according to ISO 3744 and is referred to a distance of 1/5/10 metres from the external surface of the unit.

DIMENSIONS AND MINIMUM OPERATING AREA

Respect the free area around the unit as shown in figure in order to guarantee a good accessibility and facilitate maintenance and control operations.

A	600 mm
B	600 mm

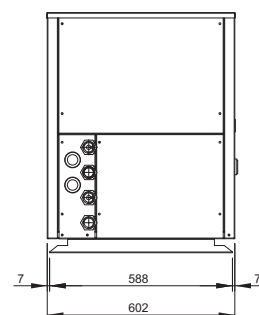
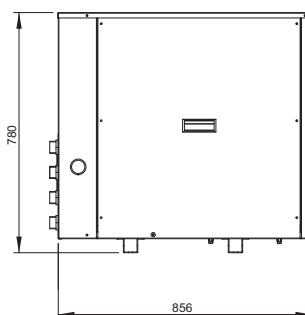
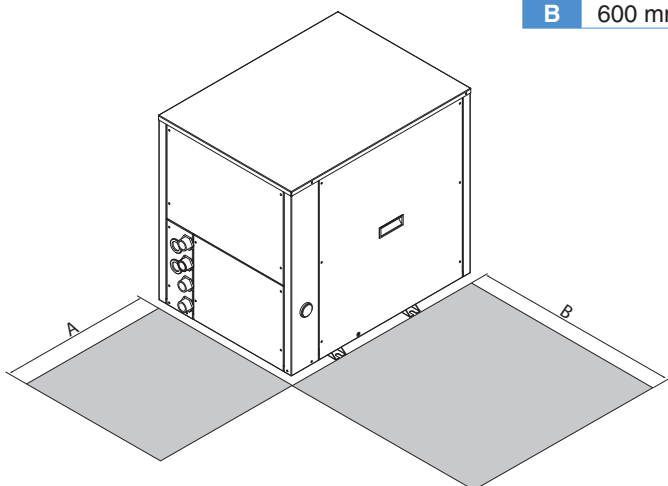

Unit with accessory
"Plant tank"

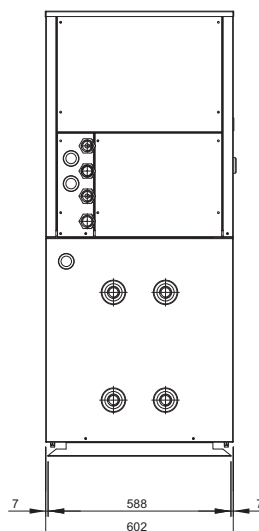
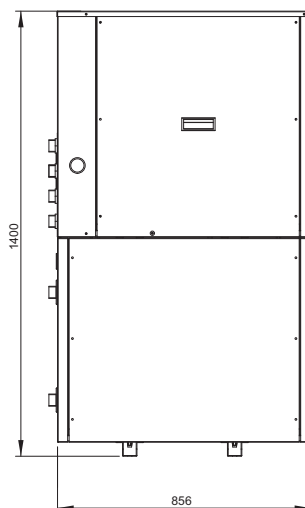
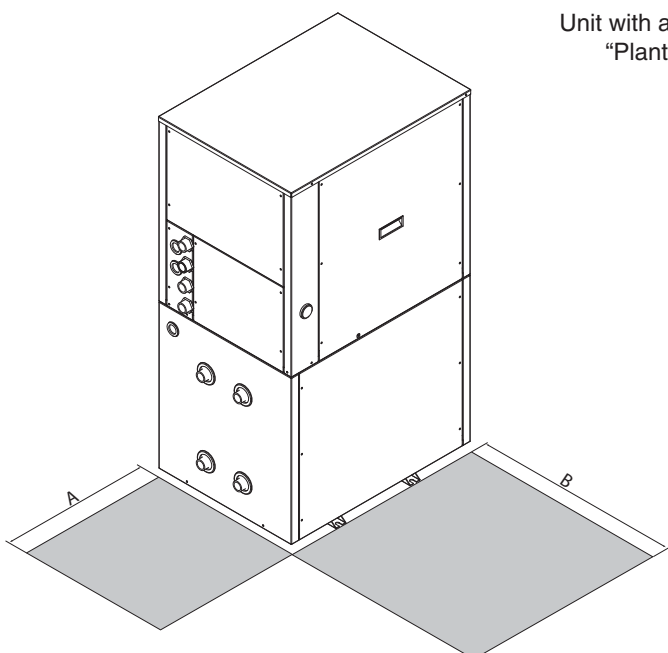

> HMW HT

WATER - WATER AND BRINE - WATER
HEAT PUMPS
FOR INDOOR INSTALLATION

Available range

Unit type

- IH Heat pump
- IP Reversible heat pump
(reversible on the refrigerant side)

Versions (heat recovery)

- VB Base version
- VD Desuperheater version

Acoustic setting up

- AB Base setting up
- AS Low noise setting up

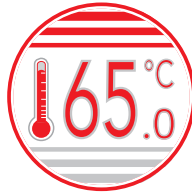

Efficiency class in heating mode - Average climate

Model	35.1	40.1	45.1	50.1	60.1
Efficiency class - medium temperature (water produce at 55°C)	A++	A++	A++	A++	A++
Efficiency class - low temperature (water produce at 35°C)	A++	A++	A++	A++	A++

NOTA: Declared according to **European regulation 811/2013**. The values are referred to units without options and accessories.

Unit description

This series of **water-water** heat pumps satisfies the heating, cooling and domestic hot water production requirements of residential plants of small and medium size.

All the units are suitable for indoor installation. The possibility to produce water at high temperatures makes these units particularly suitable to be applied to **radiators** plants as well as to **fan coil** plants and **radiant** floor plants.

As source both water (from well, river, lake...) or brine solutions (from geothermic probes) can be used.

The control system allows to manage not only the refrigerant circuit but the whole plant with the possibility to choose different solutions both for the heating and cooling plant and for the domestic hot water management. The possibility of solar panels or other heating sources integration is also available. The **heating** function optimizes the flow water temperature according both to the ambient temperature and to the outdoor temperature through climatic curves adaptable to the building features. It's possible to manage a storage tank and two independent circuits (a direct one and a mixed one). The **domestic hot water** management allows to control the three way valve, the storage tank and the anti-legionella cycles (if necessary).

The **cooling** function can be realized through "passive cooling" (free cooling), through "active cooling" (refrigerant circuit inversion) or through both systems actuated in sequence. When the unit is used in radiant floor plants, to avoid condensate generation, a room humidity sensor can be installed. During cooling mode operation a

part of the heating power in excess can be recovered for the domestic hot water production (VD version).

The **internal programmer clock** allows to define different daily switching programs for heating, cooling and domestic hot water production. The refrigerant circuit is equipped with scroll compressor mounted on damper supports, brazed plate heat exchangers, electronic expansion valve and reverse cycle valve (for reversible units). The circuit is protected by high and low pressure switches and flow switches on both the exchangers. The compressors are arranged in tandem on a single refrigerant circuit and allow the capacity modulation according to the plant requests in order to guarantee a high seasonal efficiency.

The compressor is equipped with vapour and liquid injection and is placed on an economized refrigerant circuit with plate heat exchanger and electronic expansion valve dedicated to the injection.

In the low noise setting up units (AS) the outdoor structure is **thermally and acoustically insulated** in order to reduce sound propagation and to allow the installation in domestic places.

The heat exchangers and all the hydraulic pipes are thermally insulated to avoid condensate generation and reduce thermal losses.

All the units are supplied with phase sequence and voltage controller and with an outdoor temperature sensor in order to realize the climatic control.

All the units are accurately built and individually tested in the factory. Only electric and hydraulic connections are required for installation.

Options

Plant side flow rate management

- not present
- standard pump
- high head pump
- modulating pump

Source side flow rate management

- not present
- standard pump
- high head pump
- modulating pump
- 2 way valve

Domestic hot water production

- not present
- 3 way valve

Passive cooling

- not present
- standard

Soft starter

- not present
- standard

Accessories

- Rubber vibration dampers
- Spring vibration dampers
- Remote thermostat (wired or wireless)
- Remote control (wired or wireless)
- Wireless transmitter
- Wireless repeater
- Condensate sensor
- Room hygostat
- Room humidity sensor

CONTROL SYSTEM

The microprocessor controller is able to manage not only the unit itself but also all that components of the plant which allow to realize a complete system.

The main **functions** of the control system are :

- room temperature control according to the outdoor temperature (climatic control)
- domestic hot water production (management of 3 way valve, storage tank, anti legionella cycles...)
- management of a heating and/or cooling mixed circuit (pump and 3 way mixing valve)
- management of a heating direct circuit (only pump)
- management of a storage tank for heating and/or cooling
- management of electrical heaters for heating and domestic hot water (3 steps logic)
- solar panels integration
- passive cooling
- room humidity control for cooling with radiant systems
- internal programmer clock (for heating, cooling and domestic hot water)
- digital input for electrical energy low tariff
- alarm memory management and diagnostic
- compressor and pump operating hour counter
- possibility to manage more units in cascade (maximum 16)

Besides the standard user interface to be placed indoor, wired or wireless remote thermostats are available which allow to control all the operating parameters of the unit and to acquire the temperature in the different zones in order to realize a more precise and comfortable control.

The unit controller is able to manage a lot of different plant solutions enabling automatically the necessary control algorithms according to the components which have been connected.

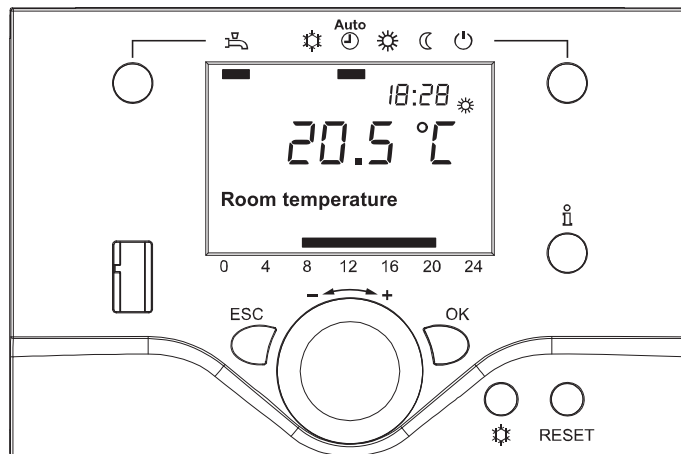

The management of such components is possible through additional expansion modules which communicate with the unit by means of an internal bus and provide all the inputs and outputs required to fulfil a complete system.

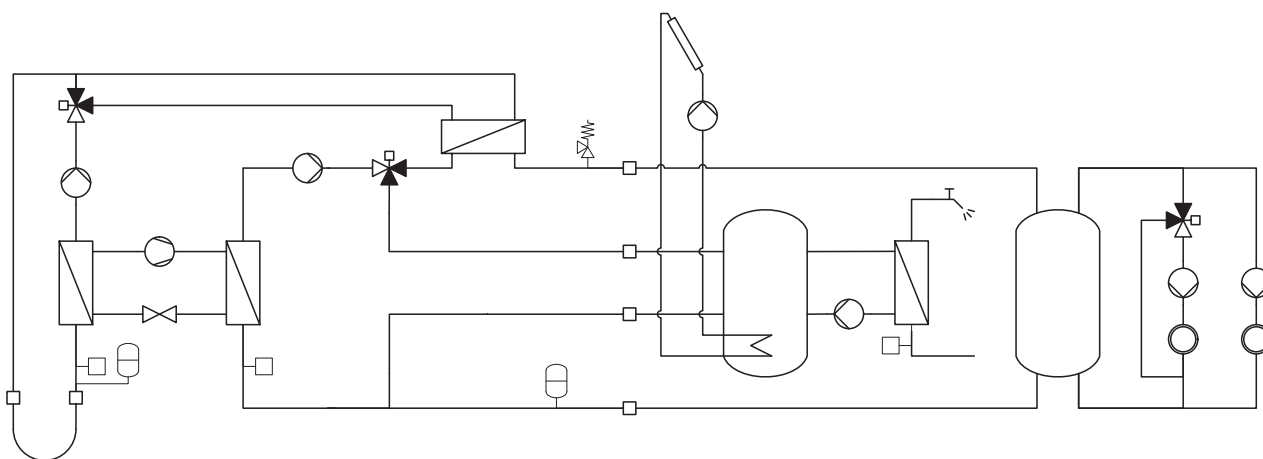

The controller is able to manage up to **two zones in heating** (one by means of a mixed circuit and the other by means of a direct circuit) and **one zone in cooling** (by means of a mixed circuit).

It's possible to realize more complex plants connecting to the heat pump controller further expansion modules in order to extend without limits the number of zones to be managed.

For each zone the following parameters can be set :

- set point
- daily or weekly operating time table
- climatic control curve
- room control sensor : it can be in common with the other zones or independent (in that case it's necessary to install an additional room thermostat)

OPERATING LIMITS	Unit type	Cooling		Heating		°C
		min	max	min	max	
Plant flow temperature	-	6	30	15	65 *	°C
Source return temperature (water)	-	5	50	5	25	°C
Source return temperature (brine)	-	-10	50	-15	25	°C

* The maximum water outlet temperature can be increased up to 70°C keeping a ΔT between inlet and outlet equal to 10°C.

NOMINAL performances - Radiant plants

IP	Acoustic setting up : AB and AS	35.1	40.1	45.1	50.1	60.1	
W10W35	Heating capacity	35,7	42,2	47,3	53,2	62,5	kW
	Power input	6,74	7,92	8,98	10,1	12,0	kW
	COP	5,30	5,33	5,27	5,27	5,21	-
	Water flow rate plant side	6148	7273	8139	9161	10737	l/h
	Pressure drops plant side	31	28	35	34	46	kPa
	Water flow rate source side	8394	9934	11135	12533	14752	l/h
	Pressure drops source side	55	52	64	62	84	kPa
B0W35	Heating capacity	27,6	32,6	36,6	41,1	48,2	kW
	Power input	6,40	7,53	8,47	9,51	11,2	kW
	COP	4,31	4,33	4,32	4,32	4,30	-
	Water flow rate plant side	4762	5628	6321	7100	8313	l/h
	Pressure drops plant side	19	18	22	21	28	kPa
	Water flow rate source side	6818	8059	9080	10193	11994	l/h
	Pressure drops source side	39	37	46	44	60	kPa
W30W18	Cooling capacity	34,8	41,1	45,9	51,7	60,5	kW
	Power input	5,91	6,94	7,83	8,79	10,4	kW
	EER	5,89	5,92	5,86	5,88	5,82	-
	Water flow rate plant side	6035	7121	7966	8966	10500	l/h
	Pressure drops plant side	30	27	34	33	44	kPa
	Water flow rate source side	7012	8274	9248	10408	12154	l/h
	Pressure drops source side	39	36	45	43	58	kPa
B30W18	Cooling capacity	34,1	40,3	45,2	50,8	59,4	kW
	Power input	6,03	7,08	8,01	8,98	10,6	kW
	EER	5,66	5,69	5,64	5,66	5,60	-
	Water flow rate plant side	5914	6983	7828	8811	10311	l/h
	Pressure drops plant side	28	26	33	32	43	kPa
	Water flow rate source side	7493	8849	9906	11149	13007	l/h
	Pressure drops source side	46	43	53	51	69	kPa

NOMINAL performances - Radiant plants

IH	Acoustic setting up : AB and AS	35.1	40.1	45.1	50.1	60.1	
W10W35	Heating capacity	36,4	43,0	48,2	54,3	63,7	kW
	Power input	6,84	8,03	9,12	10,2	12,2	kW
	COP	5,32	5,35	5,29	5,32	5,22	-
	Water flow rate plant side	6269	7412	8295	9352	10945	l/h
	Pressure drops plant side	32	29	36	35	47	kPa
	Water flow rate source side	8576	10143	11367	12822	15066	l/h
	Pressure drops source side	58	54	67	64	87	kPa
B0W35	Heating capacity	28,2	33,2	37,3	42,0	49,1	kW
	Power input	6,48	7,63	8,58	9,64	11,3	kW
	COP	4,35	4,35	4,35	4,36	4,35	-
	Water flow rate plant side	4866	5732	6442	7256	8468	l/h
	Pressure drops plant side	20	18	23	22	29	kPa
	Water flow rate source side	6990	8227	9277	10451	12249	l/h
	Pressure drops source side	41	38	48	46	62	kPa

Data declared according to **EN 14511**. The values are referred to units without options or accessories. Brine = water with 30% ethylene glycol.

W10W65 = source: water in 10°C out 7°C / plant: water in 55°C out 65°C
 W10W55 = source: water in 10°C out 7°C / plant: water in 47°C out 55°C
 W10W45 = source: water in 10°C out 7°C / plant: water in 40°C out 45°C
 W10W35 = source: water in 10°C out 7°C / plant: water in 30°C out 35°C
 W30W7 = source: water in 30°C out 35°C / plant: water in 12°C out 7°C
 W30W18 = source: water in 30°C out 35°C / plant: water in 23°C out 18°C

B0W65 = source: brine in 0°C out -3°C / plant: water in 55°C out 65°C
 B0W55 = source: brine in 0°C out -3°C / plant: water in 47°C out 55°C
 B0W45 = source: brine in 0°C out -3°C / plant: water in 40°C out 45°C
 B0W35 = source: brine in 0°C out -3°C / plant: water in 30°C out 35°C
 B30W7 = source: brine in 30°C out 35°C / plant: water in 12°C out 7°C
 B30W18 = source: brine in 30°C out 35°C / plant: water in 23°C out 18°C

NOMINAL performances - Standard plants

IP	Acoustic setting up : AB and AS	35.1	40.1	45.1	50.1	60.1	
W10W45	Heating capacity	36,5	43,1	48,3	54,3	63,8	kW
	Power input	8,27	9,71	11,0	12,3	14,6	kW
	COP	4,41	4,44	4,39	4,41	4,37	-
	Water flow rate plant side	6309	7456	8342	9385	11001	l/h
	Pressure drops plant side	32	30	37	35	48	kPa
	Water flow rate source side	8182	9671	10835	12207	14380	l/h
	Pressure drops source side	53	49	61	59	80	kPa
B0W45	Heating capacity	28,3	33,4	37,4	42,0	49,3	kW
	Power input	7,93	9,33	10,5	11,7	13,7	kW
	COP	3,57	3,58	3,56	3,59	3,60	-
	Water flow rate plant side	4901	5787	6482	7282	8533	l/h
	Pressure drops plant side	20	18	23	22	30	kPa
	Water flow rate source side	6547	7734	8688	9767	11517	l/h
	Pressure drops source side	36	34	42	40	55	kPa
W30W7	Cooling capacity	26,5	31,3	35,1	39,5	46,2	kW
	Power input	5,80	6,82	7,65	8,60	9,99	kW
	EER	4,57	4,59	4,59	4,59	4,62	-
	Water flow rate plant side	4565	5389	6041	6796	7963	l/h
	Pressure drops plant side	17	16	20	19	26	kPa
	Water flow rate source side	5576	6581	7367	8288	9674	l/h
	Pressure drops source side	25	24	29	28	38	kPa
B30W7	Cooling capacity	26,0	30,7	34,5	38,8	45,4	kW
	Power input	5,90	6,94	7,78	8,74	10,2	kW
	EER	4,41	4,42	4,43	4,44	4,45	-
	Water flow rate plant side	4479	5286	5938	6676	7826	l/h
	Pressure drops plant side	17	16	19	19	25	kPa
	Water flow rate source side	5972	7048	7901	8885	10370	l/h
	Pressure drops source side	30	28	35	33	45	kPa

NOMINAL performances - Standard plants

IH	Acoustic setting up : AB and AS	35.1	40.1	45.1	50.1	60.1	
W10W45	Heating capacity	37,2	43,9	49,2	55,5	65,0	kW
	Power input	8,38	9,84	11,1	12,5	14,7	kW
	COP	4,44	4,46	4,43	4,44	4,42	-
	Water flow rate plant side	6430	7595	8498	9593	11210	l/h
	Pressure drops plant side	33	31	38	37	50	kPa
	Water flow rate source side	8359	9874	11064	12493	14694	l/h
	Pressure drops source side	55	51	63	61	83	kPa
B0W45	Heating capacity	28,9	34,0	38,1	43,1	50,3	kW
	Power input	8,02	9,44	10,6	12,0	13,9	kW
	COP	3,60	3,60	3,59	3,59	3,62	-
	Water flow rate plant side	5005	5892	6604	7456	8707	l/h
	Pressure drops plant side	21	19	24	23	31	kPa
	Water flow rate source side	6716	7896	8876	10022	11803	l/h
	Pressure drops source side	38	35	44	42	58	kPa

Data declared according to **EN 14511**. The values are referred to units without options or accessories. Brine = water with 30% ethylene glycol.

W10W65 = source: water in 10°C out 7°C / plant: water in 55°C out 65°C
 W10W55 = source: water in 10°C out 7°C / plant: water in 47°C out 55°C
 W10W45 = source: water in 10°C out 7°C / plant: water in 40°C out 45°C
 W10W35 = source: water in 10°C out 7°C / plant: water in 30°C out 35°C
 W30W7 = source: water in 30°C out 35°C / plant: water in 12°C out 7°C
 W30W18 = source: water in 30°C out 35°C / plant: water in 23°C out 18°C

B0W65 = source: brine in 0°C out -3°C / plant: water in 55°C out 65°C
 B0W55 = source: brine in 0°C out -3°C / plant: water in 47°C out 55°C
 B0W45 = source: brine in 0°C out -3°C / plant: water in 40°C out 45°C
 B0W35 = source: brine in 0°C out -3°C / plant: water in 30°C out 35°C
 B30W7 = source: brine in 30°C out 35°C / plant: water in 12°C out 7°C
 B30W18 = source: brine in 30°C out 35°C / plant: water in 23°C out 18°C

NOMINAL performances - HIGH temperature and VERY HIGH temperature plants

IP	Acoustic setting up : AB and AS	35.1	40.1	45.1	50.1	60.1	
W10W65	Heating capacity	39,2	46,4	51,9	58,5	68,5	kW
	Power input	11,9	13,9	15,6	17,6	20,4	kW
	COP	3,29	3,34	3,33	3,32	3,36	-
	Water flow rate plant side	3429	4059	4541	5109	5984	l/h
	Pressure drops plant side	10	9	12	11	15	kPa
	Water flow rate source side	7919	9406	10549	11864	14037	l/h
	Pressure drops source side	49	47	58	56	76	kPa
B0W65	Heating capacity	31,1	36,8	41,2	46,3	54,3	kW
	Power input	11,6	13,7	15,2	17,2	19,8	kW
	COP	2,68	2,69	2,71	2,69	2,74	-
	Water flow rate plant side	2721	3219	3604	4051	4750	l/h
	Pressure drops plant side	6	6	7	7	10	kPa
	Water flow rate source side	6267	7413	8367	9385	11167	l/h
	Pressure drops source side	33	31	39	38	52	kPa
W10W55	Heating capacity	37,6	44,5	49,8	56,0	65,6	kW
	Power input	9,75	11,5	12,9	14,4	16,9	kW
	COP	3,86	3,87	3,86	3,89	3,88	-
	Water flow rate plant side	4086	4838	5415	6091	7137	l/h
	Pressure drops plant side	14	13	16	16	21	kPa
	Water flow rate source side	8056	9548	10721	12064	14237	l/h
	Pressure drops source side	51	48	60	57	79	kPa
B0W55	Heating capacity	29,3	34,7	38,9	43,7	51,3	kW
	Power input	9,48	11,2	12,5	14,1	16,2	kW
	COP	3,09	3,10	3,11	3,10	3,17	-
	Water flow rate plant side	3193	3781	4239	4762	5579	l/h
	Pressure drops plant side	9	8	10	10	13	kPa
	Water flow rate source side	6379	7572	8526	9544	11326	l/h
	Pressure drops source side	35	32	41	39	54	kPa

NOMINAL performances - HIGH temperature and VERY HIGH temperature plants

IH	Acoustic setting up : AB and AS	35.1	40.1	45.1	50.1	60.1	
W10W65	Heating capacity	40,0	47,3	53,0	59,7	69,8	kW
	Power input	12,0	14,1	15,9	17,8	20,6	kW
	COP	3,33	3,35	3,33	3,35	3,39	-
	Water flow rate plant side	3499	4138	4628	5214	6098	l/h
	Pressure drops plant side	10	10	12	12	16	kPa
	Water flow rate source side	8119	9634	10778	12150	14351	l/h
	Pressure drops source side	52	49	60	58	80	kPa
B0W65	Heating capacity	31,8	37,5	42,0	47,4	55,3	kW
	Power input	11,7	13,8	15,5	17,4	20,0	kW
	COP	2,72	2,72	2,71	2,72	2,77	-
	Water flow rate plant side	2782	3281	3674	4147	4838	l/h
	Pressure drops plant side	7	6	8	7	10	kPa
	Water flow rate source side	6458	7604	8558	9672	11421	l/h
	Pressure drops source side	35	33	41	40	54	kPa
W10W55	Heating capacity	38,4	45,3	50,7	57,1	66,8	kW
	Power input	9,88	11,6	13,0	14,7	17,1	kW
	COP	3,89	3,91	3,90	3,88	3,91	-
	Water flow rate plant side	4173	4925	5514	6211	7268	l/h
	Pressure drops plant side	15	14	17	16	22	kPa
	Water flow rate source side	8259	9749	10949	12322	14523	l/h
	Pressure drops source side	54	50	62	60	82	kPa
B0W55	Heating capacity	30,0	35,3	39,6	44,7	52,3	kW
	Power input	9,60	11,3	12,7	14,2	16,5	kW
	COP	3,13	3,12	3,12	3,15	3,17	-
	Water flow rate plant side	3269	3846	4315	4871	5688	l/h
	Pressure drops plant side	9	8	11	10	14	kPa
	Water flow rate source side	6570	7731	8685	9831	11580	l/h
	Pressure drops source side	37	34	42	41	56	kPa

TECHNICAL DATA	35.1	40.1	45.1	50.1	60.1	
Power supply	400-3-50					V-ph-Hz
Compressor type	scroll with vapour injection (EVI)					-
N° compressors / N° refrigerant circuits	1 / 1					n°
Plant side heat exchanger type	stainless steel brazed plates					-
Source side heat exchanger type	stainless steel brazed plates					-
Hydraulic fittings	1"1/2 M					-
Hydraulic fittings heat recovery (VD)	1"1/4 M					-
Weight *	411	421	421	433	434	kg
Maximum power input *	13,3	14,9	16,5	18,8	21,7	kW

* base unit without options and accessories

ACOUSTIC PERFORMANCES

Base acoustic setting up (AB)	35.1	40.1	45.1	50.1	60.1	
Sound power level	64	65	66	67	68	dB(A)
Sound pressure level at 1 metre	48	49	50	51	52	dB(A)
Sound pressure level at 5 metres	38	39	40	41	42	dB(A)
Sound pressure level at 10 metres	33	34	35	36	37	dB(A)
Low noise acoustic setting up (AS)	35.1	40.1	45.1	50.1	60.1	
Sound power level	58	59	60	61	62	dB(A)
Sound pressure level at 1 metre	42	43	44	45	46	dB(A)
Sound pressure level at 5 metres	32	33	34	35	36	dB(A)
Sound pressure level at 10 metres	27	28	29	30	31	dB(A)

The acoustic performances are referred to units operating in cooling mode at nominal conditions W10W35.

Unit placed in free field on reflecting surface (directional factor equal to 2).

The sound power level is measured according to ISO 3744 standard.

The sound pressure level is calculated according to ISO 3744 and is referred to a distance of 1/5/10 metres from the external surface of the unit.

DIMENSIONS AND MINIMUM OPERATING AREA

Respect the free area around the unit as shown in figure in order to guarantee a good accessibility and facilitate maintenance and control operations.

A	600 mm
B	600 mm

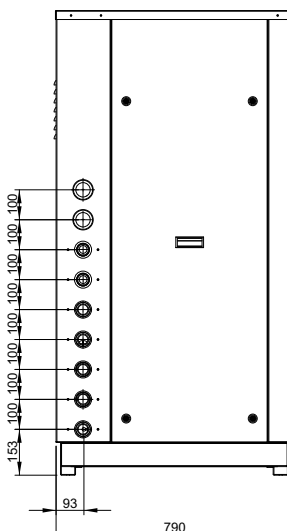
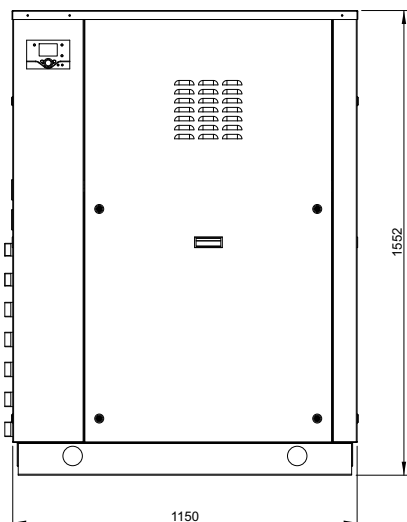
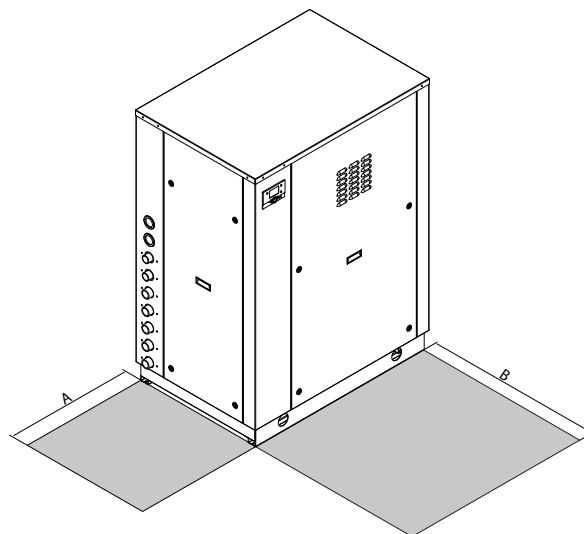

> HGW HT

WATER - WATER AND BRINE - WATER
HEAT PUMPS
FOR INDOOR INSTALLATION

Available range

Unit type

- IH Heat pump
- IP Reversible heat pump
(reversible on the refrigerant side)

Versions (heat recovery)

- VB Base version
- VD Desuperheater version

Acoustic setting up

- AB Base setting up
- AS Low noise setting up

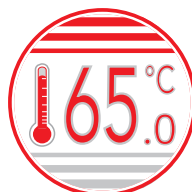

Efficiency class in heating mode - Average climate

Model	70.2	80.2	90.2	100.2	120.2
Efficiency class - medium temperature (water produce at 55°C)	A++	A++	A++	A++	A++
Efficiency class - low temperature (water produce at 35°C)	A++	A++	A++	A++	A++

NOTA: Declared according to **European regulation 811/2013**. The values are referred to units without options and accessories.

Unit description

This series of **water-water** heat pumps satisfies the heating, cooling and domestic hot water production requirements of autonomous or centralized residential plants of medium and large size. All the units are suitable for indoor installation. The possibility to produce water at high temperatures makes these units particularly suitable to be applied to **radiators** plants as well as to **fan coil** plants and **radiant** floor plants.

As source both water (from well, river, lake...) or brine solutions (from geothermic probes) can be used. The control system allows to manage not only the refrigerant circuit but the whole plant with the possibility to choose different solutions both for the heating and cooling plant and for the domestic hot water management. The possibility of solar panels or other heating sources integration is also available.

The **heating** function optimizes the flow water temperature according both to the ambient temperature and to the outdoor temperature through climatic curves adaptable to the building features. It's possible to manage a storage tank and two independent circuits (a direct one and a mixed one). The **domestic hot water** management allows to control the three way valve, the storage tank and the anti-legionella cycles (if necessary). The **cooling** function can be realized through "passive cooling" (free cooling), through "active cooling" (refrigerant circuit inversion) or through both systems actuated in sequence. When the unit is used in radiant floor plants, to avoid condensate generation, a room humidity sensor can be installed. During cooling mode operation a part of the heating po-

wer in excess can be recovered for the domestic hot water production (VD version).

The **internal programmer clock** allows to define different daily switching programs for heating, cooling and domestic hot water production.

The refrigerant circuit is equipped with scroll compressors mounted on damper supports, brazed plate heat exchangers, electronic expansion valve and reverse cycle valve (for reversible units). The circuit is protected by high and low pressure switches and flow switches on both the exchangers. The compressors are arranged in tandem on a single refrigerant circuit and allow the capacity modulation according to the plant requests in order to guarantee a high seasonal efficiency.

Both the compressors are equipped with vapour and liquid injection and are placed on an economized refrigerant circuit equipped with a plate heat exchanger and an electronic expansion valve dedicated to the injection. In the low noise setting up units (AS) the outdoor structure is **thermally and acoustically insulated** in order to reduce sound propagation and to allow the installation in domestic places.

The heat exchangers and all the hydraulic pipes are thermally insulated to avoid condensate generation and reduce thermal losses. All the units are supplied with phase sequence and voltage controller and with an outdoor temperature sensor in order to realize the climatic control.

All the units are accurately built and individually tested in the factory. Only electric and hydraulic connections are required for installation.

Options

Plant side flow rate management

- not present
- standard pump
- high head pump
- modulating pump

Source side flow rate management

- not present
- standard pump
- high head pump
- modulating pump
- 2 way valve

Domestic hot water production

- not present
- 3 way valve

Passive cooling

- not present
- standard

Soft starter

- not present
- standard

Accessories

- Rubber vibration dampers
- Spring vibration dampers
- Remote thermostat (wired or wireless)
- Remote control (wired or wireless)
- Wireless transmitter
- Wireless repeater
- Condensate sensor
- Room hygrosat
- Room humidity sensor

CONTROL SYSTEM

The microprocessor controller is able to manage not only the unit itself but also all that components of the plant which allow to realize a complete system.

The main **functions** of the control system are :

- room temperature control according to the outdoor temperature (climatic control)
- domestic hot water production (management of 3 way valve, storage tank, anti legionella cycles...)
- management of a heating and/or cooling mixed circuit (pump and 3 way mixing valve)
- management of a heating direct circuit (only pump)
- management of a storage tank for heating and/or cooling
- management of electrical heaters for heating and domestic hot water (3 steps logic)
- solar panels integration
- passive cooling
- room humidity control for cooling with radiant systems
- internal programmer clock (for heating, cooling and domestic hot water)
- digital input for electrical energy low tariff
- alarm memory management and diagnostic
- compressor and pump operating hour counter
- possibility to manage more units in cascade (maximum 16)

Besides the standard user interface to be placed indoor, wired or wireless remote thermostats are available which allow to control all the operating parameters of the unit and to acquire the temperature in the different zones in order to realize a more precise and comfortable control.

The unit controller is able to manage a lot of different plant solutions enabling automatically the necessary control algorithms according to the components which have been connected.

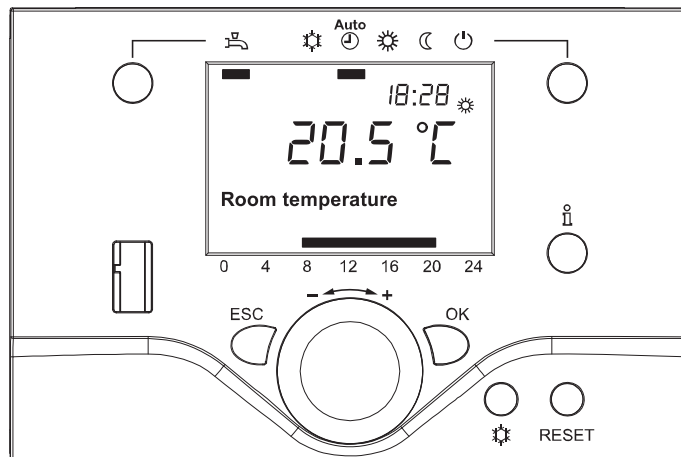

The management of such components is possible through additional expansion modules which communicate with the unit by means of an internal bus and provide all the inputs and outputs required to fulfil a complete system.

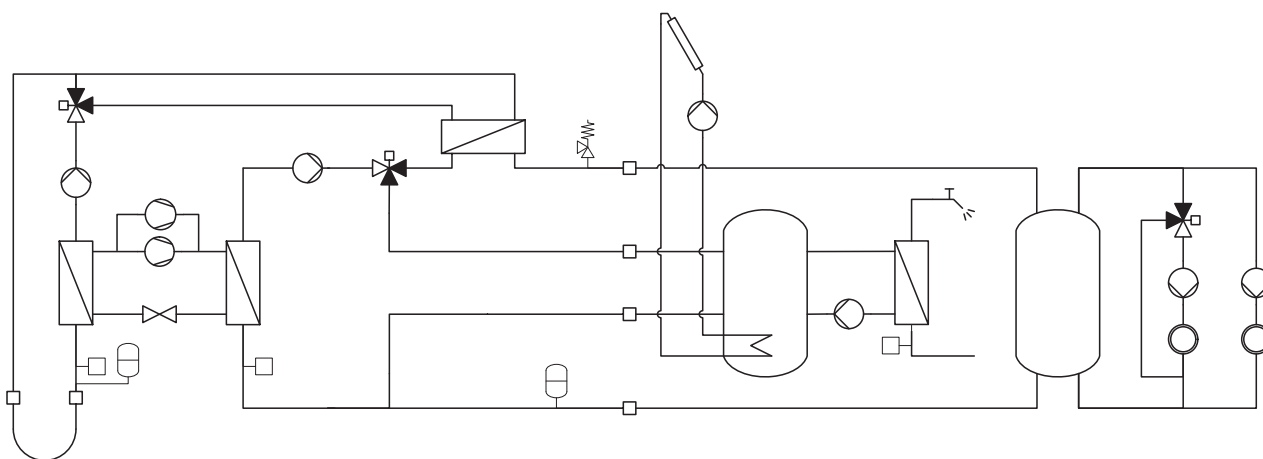

The controller is able to manage up to **two zones in heating** (one by means of a mixed circuit and the other by means of a direct circuit) and **one zone in cooling** (by means of a mixed circuit).

It's possible to realize more complex plants connecting to the heat pump controller further expansion modules in order to extend without limits the number of zones to be managed.

For each zone the following parameters can be set :

- set point
- daily or weekly operating time table
- climatic control curve
- room control sensor : it can be in common with the other zones or independent (in that case it's necessary to install an additional room thermostat)

OPERATING LIMITS	Unit type	Cooling		Heating		°C
		min	max	min	max	
Plant flow temperature	-	6	30	15	65 *	°C
Source return temperature (water)	-	5	50	5	25	°C
Source return temperature (brine)	-	-10	50	-15	25	°C

* The maximum water outlet temperature can be increased up to 70°C keeping a ΔT between inlet and outlet equal to 10°C.

NOMINAL performances - Radiant plants

IP	Acoustic setting up : AB and AS	70.2	80.2	90.2	100.2	120.2	
W10W35	Heating capacity	69,1	81,4	91,0	102	120	kW
	Power input	12,7	15,0	16,8	18,8	22,0	kW
	COP	5,44	5,43	5,42	5,43	5,45	-
	Water flow rate plant side	11915	14027	15673	17664	20625	l/h
	Pressure drops plant side	31	33	33	30	30	kPa
	Water flow rate source side	16267	19154	21384	24128	28131	l/h
	Pressure drops source side	30	33	33	30	30	kPa
B0W35	Heating capacity	53,5	62,9	70,3	79,1	92,6	kW
	Power input	12,1	14,3	16,1	18,0	21,2	kW
	COP	4,42	4,40	4,37	4,39	4,37	-
	Water flow rate plant side	9230	10858	12140	13664	15984	l/h
	Pressure drops plant side	19	21	21	19	19	kPa
	Water flow rate source side	13235	15557	17371	19566	22843	l/h
	Pressure drops source side	22	24	24	21	21	kPa
W30W18	Cooling capacity	67,3	79,1	88,4	99,6	116	kW
	Power input	11,3	13,2	14,9	16,6	19,6	kW
	EER	5,96	5,99	5,93	6,00	5,92	-
	Water flow rate plant side	11656	13707	15328	17259	20173	l/h
	Pressure drops plant side	29	32	32	29	29	kPa
	Water flow rate source side	13560	15932	17837	20071	23483	l/h
	Pressure drops source side	22	23	24	21	21	kPa
B30W18	Cooling capacity	66,1	77,6	86,9	97,9	114	kW
	Power input	11,4	13,4	15,1	16,9	19,9	kW
	EER	5,80	5,79	5,75	5,79	5,73	-
	Water flow rate plant side	11449	13449	15052	16949	19811	l/h
	Pressure drops plant side	28	31	31	28	28	kPa
	Water flow rate source side	14517	17036	19086	21493	25141	l/h
	Pressure drops source side	26	28	28	25	25	kPa

NOMINAL performances - Radiant plants

IH	Acoustic setting up : AB and AS	70.2	80.2	90.2	100.2	120.2	
W10W35	Heating capacity	70,6	83,1	92,8	105	122	kW
	Power input	12,8	15,2	17,1	19,0	22,3	kW
	COP	5,52	5,47	5,43	5,53	5,47	-
	Water flow rate plant side	12157	14304	15984	18010	21041	l/h
	Pressure drops plant side	32	34	35	31	31	kPa
	Water flow rate source side	16638	19583	21841	24643	28760	l/h
	Pressure drops source side	32	34	35	31	31	kPa
B0W35	Heating capacity	54,5	64,2	71,6	80,8	94,4	kW
	Power input	12,3	14,5	16,4	18,3	21,5	kW
	COP	4,43	4,43	4,37	4,42	4,39	-
	Water flow rate plant side	9404	11083	12365	13941	16296	l/h
	Pressure drops plant side	20	22	22	19	20	kPa
	Water flow rate source side	13521	15939	17721	20011	23352	l/h
	Pressure drops source side	23	25	25	22	22	kPa

Data declared according to **EN 14511**. The values are referred to units without options or accessories. Brine = water with 30% ethylene glycol.

W10W65 = source: water in 10°C out 7°C / plant: water in 55°C out 65°C
 W10W55 = source: water in 10°C out 7°C / plant: water in 47°C out 55°C
 W10W45 = source: water in 10°C out 7°C / plant: water in 40°C out 45°C
 W10W35 = source: water in 10°C out 7°C / plant: water in 30°C out 35°C
 W30W7 = source: water in 30°C out 35°C / plant: water in 12°C out 7°C
 W30W18 = source: water in 30°C out 35°C / plant: water in 23°C out 18°C

B0W65 = source: brine in 0°C out -3°C / plant: water in 55°C out 65°C
 B0W55 = source: brine in 0°C out -3°C / plant: water in 47°C out 55°C
 B0W45 = source: brine in 0°C out -3°C / plant: water in 40°C out 45°C
 B0W35 = source: brine in 0°C out -3°C / plant: water in 30°C out 35°C
 B30W7 = source: brine in 30°C out 35°C / plant: water in 12°C out 7°C
 B30W18 = source: brine in 30°C out 35°C / plant: water in 23°C out 18°C

NOMINAL performances - Standard plants

IP	Acoustic setting up : AB and AS	70.2	80.2	90.2	100.2	120.2	
W10W45	Heating capacity	70,6	83,2	92,9	105	122	kW
	Power input	15,7	18,5	20,8	23,1	27,2	kW
	COP	4,50	4,50	4,47	4,55	4,49	-
	Water flow rate plant side	12200	14373	16058	18092	21133	l/h
	Pressure drops plant side	32	34	35	31	31	kPa
	Water flow rate source side	15809	18640	20784	23471	27359	l/h
	Pressure drops source side	29	31	32	28	28	kPa
B0W45	Heating capacity	54,8	64,3	72,0	81,1	94,8	kW
	Power input	15,1	17,9	20,1	22,5	26,4	kW
	COP	3,63	3,59	3,58	3,60	3,59	-
	Water flow rate plant side	9489	11140	12461	14042	16423	l/h
	Pressure drops plant side	20	22	22	20	20	kPa
	Water flow rate source side	12694	14857	16607	18739	21888	l/h
	Pressure drops source side	20	22	22	20	20	kPa
W30W7	Cooling capacity	51,4	60,3	67,5	76,0	88,9	kW
	Power input	11,2	13,2	14,8	16,5	19,5	kW
	EER	4,59	4,57	4,56	4,61	4,56	-
	Water flow rate plant side	8838	10383	11618	13077	15291	l/h
	Pressure drops plant side	18	19	20	17	17	kPa
	Water flow rate source side	10806	12694	14218	15984	18721	l/h
	Pressure drops source side	14	15	16	14	14	kPa
B30W7	Cooling capacity	50,5	59,2	66,3	74,6	87,3	kW
	Power input	11,3	13,3	15,0	16,8	19,6	kW
	EER	4,47	4,45	4,42	4,44	4,45	-
	Water flow rate plant side	8684	10194	11412	12837	15016	l/h
	Pressure drops plant side	17	19	19	17	17	kPa
	Water flow rate source side	11583	13595	15231	17130	20045	l/h
	Pressure drops source side	17	18	18	16	16	kPa

NOMINAL performances - Standard plants

IH	Acoustic setting up : AB and AS	70.2	80.2	90.2	100.2	120.2	
W10W45	Heating capacity	72,1	84,8	94,7	107	125	kW
	Power input	15,8	18,7	21,1	23,5	27,6	kW
	COP	4,56	4,53	4,49	4,55	4,53	-
	Water flow rate plant side	12461	14651	16371	18439	21568	l/h
	Pressure drops plant side	33	36	36	32	32	kPa
	Water flow rate source side	16210	19068	21241	23957	27988	l/h
	Pressure drops source side	30	33	33	29	29	kPa
B0W45	Heating capacity	55,8	65,7	73,4	82,7	96,6	kW
	Power input	15,3	18,1	20,3	22,7	26,7	kW
	COP	3,65	3,63	3,62	3,64	3,62	-
	Water flow rate plant side	9663	11383	12704	14320	16736	l/h
	Pressure drops plant side	21	23	23	20	20	kPa
	Water flow rate source side	12948	15271	16989	19184	22365	l/h
	Pressure drops source side	21	23	23	20	20	kPa

Data declared according to **EN 14511**. The values are referred to units without options or accessories. Brine = water with 30% ethylene glycol.

W10W65 = source: water in 10°C out 7°C / plant: water in 55°C out 65°C
 W10W55 = source: water in 10°C out 7°C / plant: water in 47°C out 55°C
 W10W45 = source: water in 10°C out 7°C / plant: water in 40°C out 45°C
 W10W35 = source: water in 10°C out 7°C / plant: water in 30°C out 35°C
 W30W7 = source: water in 30°C out 35°C / plant: water in 12°C out 7°C
 W30W18 = source: water in 30°C out 35°C / plant: water in 23°C out 18°C

B0W65 = source: brine in 0°C out -3°C / plant: water in 55°C out 65°C
 B0W55 = source: brine in 0°C out -3°C / plant: water in 47°C out 55°C
 B0W45 = source: brine in 0°C out -3°C / plant: water in 40°C out 45°C
 B0W35 = source: brine in 0°C out -3°C / plant: water in 30°C out 35°C
 B30W7 = source: brine in 30°C out 35°C / plant: water in 12°C out 7°C
 B30W18 = source: brine in 30°C out 35°C / plant: water in 23°C out 18°C

NOMINAL performances - HIGH temperature and VERY HIGH temperature plants

IP	Acoustic setting up : AB and AS	70.2	80.2	90.2	100.2	120.2	
W10W65	Heating capacity	76,0	89,4	99,9	113	132	kW
	Power input	22,7	26,7	29,9	33,6	39,5	kW
	COP	3,35	3,35	3,34	3,36	3,34	-
	Water flow rate plant side	6640	7812	8731	9842	11496	l/h
	Pressure drops plant side	10	11	11	10	10	kPa
	Water flow rate source side	15352	18068	20155	22756	26501	l/h
	Pressure drops source side	27	30	30	27	27	kPa
B0W65	Heating capacity	60,3	70,9	79,3	89,3	104	kW
	Power input	22,2	26,3	29,4	33,1	38,9	kW
	COP	2,72	2,70	2,70	2,70	2,67	-
	Water flow rate plant side	5275	6203	6938	7812	9133	l/h
	Pressure drops plant side	7	7	8	7	7	kPa
	Water flow rate source side	12185	14285	15971	18007	20966	l/h
	Pressure drops source side	19	20	20	18	18	kPa
W10W55	Heating capacity	72,7	85,6	95,7	108	126	kW
	Power input	18,5	21,9	24,5	27,4	32,4	kW
	COP	3,93	3,91	3,91	3,94	3,89	-
	Water flow rate plant side	7911	9316	10406	11724	13708	l/h
	Pressure drops plant side	14	16	16	14	14	kPa
	Water flow rate source side	15609	18382	20498	23128	26959	l/h
	Pressure drops source side	28	31	31	27	27	kPa
B0W55	Heating capacity	57,0	66,9	74,9	84,3	98,5	kW
	Power input	18,2	21,4	24,1	27,0	31,8	kW
	COP	3,13	3,13	3,11	3,12	3,10	-
	Water flow rate plant side	6200	7279	8150	9175	10722	l/h
	Pressure drops plant side	9	10	10	9	9	kPa
	Water flow rate source side	12408	14539	16257	18325	21347	l/h
	Pressure drops source side	19	21	21	19	19	kPa











NOMINAL performances - HIGH temperature and VERY HIGH temperature plants

IH	Acoustic setting up : AB and AS	70.2	80.2	90.2	100.2	120.2	
W10W65	Heating capacity	77,5	91,2	102	115	134	kW
	Power input	22,8	26,9	30,4	33,9	39,8	kW
	COP	3,40	3,39	3,36	3,39	3,37	-
	Water flow rate plant side	6771	7970	8906	10035	11723	l/h
	Pressure drops plant side	11	12	12	11	11	kPa
	Water flow rate source side	15752	18525	20612	23299	27159	l/h
	Pressure drops source side	29	31	31	28	28	kPa
B0W65	Heating capacity	61,4	72,3	80,8	91,2	106	kW
	Power input	22,5	26,5	29,9	33,5	39,3	kW
	COP	2,73	2,73	2,70	2,72	2,70	-
	Water flow rate plant side	5372	6325	7060	7970	9308	l/h
	Pressure drops plant side	7	8	8	7	7	kPa
	Water flow rate source side	12471	14666	16289	18452	21475	l/h
	Pressure drops source side	19	21	21	19	19	kPa
W10W55	Heating capacity	74,2	87,3	97,6	110	128	kW
	Power input	18,7	22,1	24,9	27,8	32,7	kW
	COP	3,97	3,95	3,92	3,96	3,91	-
	Water flow rate plant side	8074	9502	10613	11953	13980	l/h
	Pressure drops plant side	15	16	16	15	15	kPa
	Water flow rate source side	15981	18811	20955	23642	27588	l/h
	Pressure drops source side	29	32	32	29	29	kPa
B0W55	Heating capacity	58,0	68,3	76,3	86,0	100	kW
	Power input	18,4	21,6	24,4	27,3	32,1	kW
	COP	3,15	3,16	3,13	3,15	3,12	-
	Water flow rate plant side	6309	7431	8303	9360	10940	l/h
	Pressure drops plant side	10	10	11	9	9	kPa
	Water flow rate source side	12662	14953	16607	18770	21888	l/h
	Pressure drops source side	20	22	22	20	20	kPa

> CONTROL ACCESSORIES OVERVIEW

Control accessories allow to use the system management algorithms already available inside the controller of each heat pump in order to optimize the overall efficiency of the system and to simplify its management and the possible remote control.

The type and the number of accessories must be selected according to the kind of plant to be realized and according to the installed heat pump model.

Remote control	
 PHASE-OUT	Replicates all the control and visualization functionalities of the controller installed on the unit. The on board temperature sensor can be used in order to realize a climatic control. Available both wired and wireless. MANDATORY accessory for all the heat pumps which are not equipped with on board user interface.
 PHASE-IN	
Remote thermostat	
	Allows operating mode selection and set point adjustment. The on board temperature sensor can be used in order to realize a climatic control. Available only wired.
LPB bus interface	
	Allows the communication on the LPB bus, used for the management of heat pump cascades and for the connection between zone controllers and heat pump controller.
Extended expansion	
	Allows to increase the number of available inputs and outputs to be used for the connection of the temperature sensors and of all the components of the plant directly managed by the heat pump. It is connected to the heat pump controller by means of the BSB communication bus.
Modbus interface	
	Allows the communication with the heat pump controller by means of the Modbus protocol on RS 485.
Temperature sensor NTC 10k	
	Temperature sensor to be placed in the plant to supply the heat pump with the informations required to manage all the components installed in the plant and directly controlled by the heat pump.
Temperature sensor NTC 10k siliconic	
	Temperature sensor with siliconic coating (suitable for high temperature) to be placed on the solar panel if the heat pump manages also the solar integration.
Web server	
	Allows the remote control of the operating state of the heat pump and of the other zone controllers that are installed in the system. Requires a Ethernet connection for the remote access.
By means of the web server it is possible : <ul style="list-style-type: none"> • modify set points and operating modes • visualize and modify configuration parameters • visualize alarms • create customized view panels • send e-mails to notify the operating state of the plant 	
Web server with integrated modem	
	Allows the remote control of the operating state of the heat pump. Requires a Ethernet connection for the remote access. The integrated modem allows only to send SMS to notify the state of the system.
By means of the web server it is possible : <ul style="list-style-type: none"> • modify set points and operating modes • visualize and modify configuration parameters • visualize alarms • create customized view panels • send SMS or e-mails to notify the operating state of the plant 	

HOW TO CONTACT US

FERROLI FRANCE

Parc TechnoLand - Z.I. du Champ Dollin
3, allée des Abruzzes - Bât. K
69800 Saint Priest
France
Tel. +33 (0)4 72 76 76 76

REPRESENTATIVE OFFICE IN UKRAINE FERROLI S.P.A.

10/17, Preobrazhenska str.
03037, Kiev
Ukraine
Tel. +38 044 537 02 39

FLJSC "FERROLIBEL"

222750, Minsk Region, Dzerzhinsk Province, Fanipol,
45, Zavodskaya str
Republic of Belarus
Tel.+37 517 16 9 79 49

MOSCOW REPRESENTATIVE OFFICE FERROLI S.P.A.

115054, , Moscow,
Piatnitskaya st. 73
Russia
Tel. +7 495 788-80-35

FERROLI LIMITED

Branston Ind Estate Lichfield Road
Burton upon Trent DE14 3HD
United Kingdom
Tel. (+44) 1283 715250

FERROLI POLAND SP. Z O.O.

UL. NARUTOWICZA 53
41-200 SOSNOWIEC
Tel. +48 604 516 300

FERROLI NEDERLAND B.V.

Takkebijsters 62
4817 BL Breda
Netherlands
Tel. +31 76 5725 725

FERROLI ROMANIA

B-dul Timisoara, nr. 104E, sector 6,
Bucuresti 061334
Romania
Tel. +40 21 444 36 50

FEROLI ESPAÑA

Avda. Italia, 2. Edif. Ferrol
28820 Coslada - Madrid
ESPAÑA
Tel. +34 91.661.23.04

FERROLI HEATING EQUIPMENT (CHINA) CO., LTD

Address: No. 9, Jianshedong Road, Taoyuan Economic
Development Zone, Heshan City, Guangdong Province
Tel: +86 750 8779888 Service hot line: 400-1000-188

QINGDAO FERROLI HVAC TECHNOLOGIES MANUFACTORY CO. LTD.

QINGDAO FERROLI BOILER & HEATING EQUIPMENTS CO. LTD.
Address: Jinling Industrial Zone, Chenyang District, Qingdao
City, Shandong Province
Tel: +86 532 66727100 Service hot line: 400-1000-188



Ferroli spa

37047 San Bonifacio (VR) Italy

Via Ritonda 78/A

tel. +39.045.6139411

fax +39.045.6103595

www.ferroli.com